

For New Technology Network

NTN®

NTN corporation

Triple-Sealed Bearings for Bearing Units

CAT. No. 3905- I / E



NTN Triple-Sealed Bearings for Bearing Units

These reliable triple-sealed bearings are dustproof and waterproof. They ensure a longer bearing life even when exposed to heavy airborne dust and splashes of foul water.



Features

Better dustproofing and waterproofing ensure a longer bearing life.

Triple-sealed bearings feature a secure bearing seal with three lips. This special seal offers reliable dustproofing and waterproofing superior to those of standard bearings used in bearing units. In addition, it ensures a longer service life, even when exposed to heavy airborne dust and splashes of foul water. (Patent pending)

Reduces maintenance cost.

A bearing life longer than that of a standard bearing unit configurations means extended maintenance intervals, greatly reduced maintenance costs (of inspection, relubrication, replacement, etc.), and increased availability of machinery.

Decreases price of the bearing unit and contributes to more compact machinery.

The triple-sealed bearing unit replaces conventional covered bearing units in certain operating conditions, greatly decreasing the cost of bearing units. In addition, if the cover is not required, the machinery can be made more compact.

Secure balled setscrew

The triple-sealed bearing is mounted on the shaft with NTN's unique balled setscrew, which features an embedded ball in its tip. Compared with knurled cup point or cup-point setscrews, the balled setscrew provides much greater resistance to loosening, as it does not readily loosen due to vibration or impact.

Interchangeability

The triple-sealed bearing unit conforms to the JIS (Japanese Industrial Standard) for UC-type bearings. It is not only ready to use as a relubricable bearing, but it also replaces the conventional bearing units of NTN and other manufacturers. It therefore serves as a ready replacement for existing bearing units.

Construction

Types

- **Low-torque triple-sealed bearing**
(Cylindrical-bore, set-screw type)
UC201D1LLJ through UC218D1LLJ
UC305D1LLJ through UC320D1LLJ

- **High-torque triple-sealed bearing**
(Cylindrical-bore, set-screw type)
UC201D1LLS through UC212D1LLS

(Square-bore type for agricultural machines)
1AS08-11/8, 4AS09-11/4, etc.

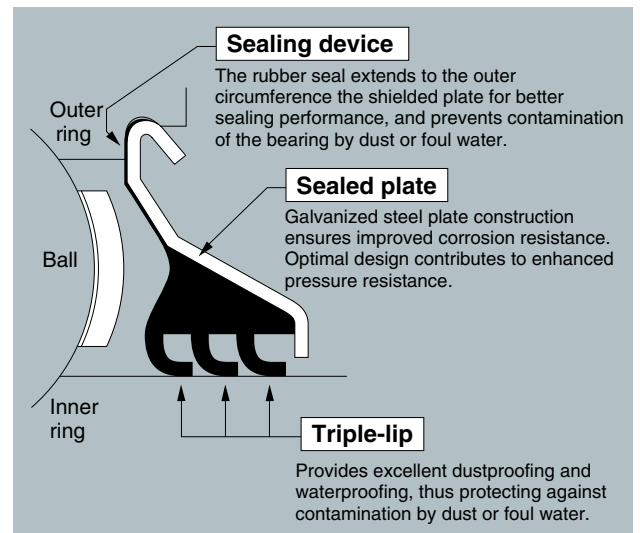

Triple-seal

Allowable Operating Temperature Range and Speed

The triple-sealed bearing can be used in a temperature range of -15°C to 100°C.

- Allowable speed Low-torque triple-sealed bearing unit... dn value : 36000
High-torque triple-sealed bearing unit... dn value : 21000

Typical Applications

Triple-sealed bearing units are suitable for machinery used in locations subjected to splashes of foul water and heavy dust, including machinery used in steel-making, casting, garbage disposal, waterworks and sewage treatment, car washers, laundry washing, food processing, fish processing, construction, transportation, agriculture, textiles, and dyeing.



Sample application :

A pillow unit (right) and a square flange unit (left) are used in a conveyor unit operating in an environment with heavy airborne dust.

Special Specifications

The standard prelubrication for bearings in this series is Li-mineral grease. Contact NTN Engineering for optional bearings lubricated with Solid Grease (heat-solidified grease) or food-grade grease, or for bearings made of stainless steel.

Triple-sealed ball bearings for bearing unit Type UC2...LLJ

Cylindrical bore with setscrew

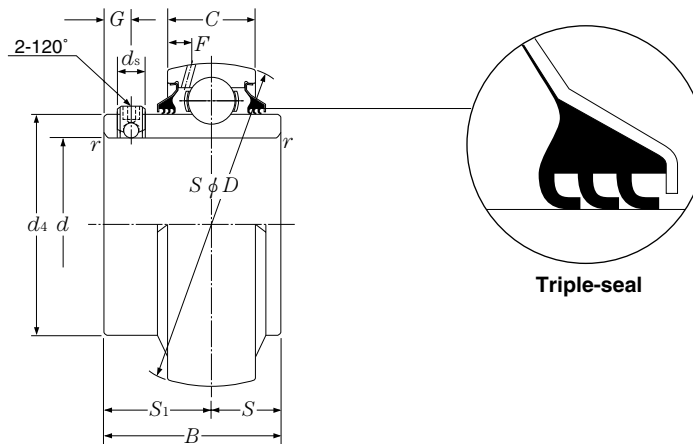

Triple-seal

Shaft dia. mm inch.	Bearing number	Nominal dimensions											basic load ratings		mass kg lb
		<i>d</i>	<i>D</i>	<i>B</i>	<i>C</i>	r_s min.	<i>S</i> mm	<i>S</i> inch.	<i>G</i>	<i>d_s</i>	<i>d₄</i>	<i>F</i>	N dynamic <i>C_r</i>	lbf static <i>C_{0r}</i>	
12 1/2	UC201D1LLJ	12	47	31	17	0.6	12.7	18.3	4.5	M5×0.8	29.6	4.7	12 800	6 650	0.21
	UC201-008D1LLJ	0.5000	1.8504	1.2205	0.6693	0.024	0.500	0.720	0.177	No.10-32UNF	1.1654	0.185	2 890	1 500	0.46
15 9/16 5/8	UC202D1LLJ	15	47	31	17	0.6	12.7	18.3	4.5	M5×0.8	29.6	4.7	12 800	6 650	0.20
	UC202-009D1LLJ	0.5625	1.8504	1.2205	0.6693	0.024	0.500	0.720	0.177	No.10-32UNF	1.1654	0.185	2 890	1 500	0.44
	UC202-010D1LLJ	0.6250													0.42
17 11/16	UC203D1LLJ	17	47	31	17	0.6	12.7	18.3	4.5	M5×0.8	29.6	4.7	12 800	6 650	0.18
	UC203-011D1LLJ	0.6875	1.8504	1.2205	0.6693	0.024	0.500	0.720	0.177	No.10-32UNF	1.1654	0.185	2 890	1 500	0.39
20 3/4	UC204D1LLJ	20	47	31	17	1	12.7	18.3	4.5	M5×0.8	29.6	4.7	12 800	6 650	0.17
	UC204-012D1LLJ	0.7500	1.8504	1.2205	0.6693	0.039	0.500	0.720	0.177	No.10-32UNF	1.1654	0.185	2 890	1 500	0.39
25 13/16 7/8 15/16 1	UC205D1LLJ	25	52	34.1	17	1	14.3	19.8	5	M5×0.8	33.9	4.5	14 000	7 850	0.20
	UC205-013D1LLJ	0.8125													0.53
	UC205-014D1LLJ	0.8750	2.0472	1.3425	0.6693	0.039	0.563	0.780	0.197	No.10-32UNF	1.3346	0.177	3 150	1 770	0.51
	UC205-015D1LLJ	0.9375													0.46
1	UC205-100D1LLJ	1.0000													0.44
30 1 1/16 1 1/8 1 3/16 1 1/4	UC206D1LLJ	30	62	38.1	19	1	15.9	22.2	5	M6×0.75	40.8	4.6	19 500	11 300	0.33
	UC206-101D1LLJ	1.0625													0.82
	UC206-102D1LLJ	1.1250	2.4409	1.5000	0.7480	0.039	0.626	0.874	0.197	1/4-28UNF	1.6063	0.181	4 400	2 540	0.77
	UC206-103D1LLJ	1.1875													0.73
1 1/4	UC206-104D1LLJ	1.2500													0.66
35 1 1/4 1 5/16 1 3/8 1 7/16	UC207D1LLJ	35	72	42.9	20	1.5	17.5	25.4	6	M6×0.75	46.8	4.6	25 700	15 300	0.49
	UC207-104D1LLJ	1.2500													1.21
	UC207-105D1LLJ	1.3125	2.8346	1.6890	0.7874	0.059	0.689	1.000	0.236	1/4-28UNF	1.8425	0.181	5 750	3 450	1.15
	UC207-106D1LLJ	1.3750													1.08
1 7/16	UC207-107D1LLJ	1.4375													1.01
40 1 1/2 1 5/16	UC208D1LLJ	40	80	49.2	21	1.5	19	30.2	8	M8×1	53	4.5	29 100	17 800	0.65
	UC208-108D1LLJ	1.5000	3.1496	1.9370	0.8268	0.059	0.748	1.189	0.315	5/16-24UNF	2.0866	0.177	6 550	4 000	1.52
	UC208-109D1LLJ	1.5625													1.46
45 1 5/8 1 11/16 1 3/4	UC209D1LLJ	45	85	49.2	22	1.5	19	30.2	8	M8×1	57.5	4.9	32 500	20 400	0.70
	UC209-110D1LLJ	1.6250													1.76
	UC209-111D1LLJ	1.6875	3.3465	1.9370	0.8661	0.059	0.748	1.189	0.315	5/16-24UNF	2.2638	0.193	7 350	4 600	1.68
	UC209-112D1LLJ	1.7500													1.57
50 1 13/16 1 7/8 1 15/16 2	UC210D1LLJ	50	90	51.6	24	1.5	19	32.6	9	M8×1	62.4	5.9	35 000	23 200	0.80
	UC210-113D1LLJ	1.8125													2.03
	UC210-114D1LLJ	1.8750	3.5433	2.0315	0.9449	0.059	0.748	1.283	0.354	5/16-24UNF	2.4567	0.232	7 900	5 200	1.92
	UC210-115D1LLJ	1.9375													1.81
2	UC210-200D1LLJ	2.0000													1.69

① Minimum allowable dimension for chamfer dimension *r*.

Note:

1) For shaft tolerances, see the Bearing Units catalog.

2) The precision of ball bearings is as specified in JIS B 1558 "Ball bearings for rolling bearing units."

3) Contact NTN Engineering for information on tapered bore ball bearings or ball bearings with bores in English measurements.

Shaft dia. mm inch.	Bearing number	Nominal dimensions											basic load ratings		mass kg lb
		<i>d</i>	<i>D</i>	<i>B</i>	<i>C</i>	<i>r_s</i> ¹ min.	mm <i>S</i>	inch. <i>S₁</i>	<i>G</i>	<i>d_s</i>	<i>d₄</i>	<i>F</i>	N dynamic <i>C_r</i>	lbf static <i>C_{0r}</i>	
55 2 2 1/16 2 1/8 2 3/16	UC211D1LLJ	55	100	55.6	25	2	22.2	33.4	9	M8×1	69	6.0	43 500	29 200	1.08
	UC211-200D1LLJ	2.0000													2.71
	UC211-201D1LLJ	2.0625	3.9370	2.1890	0.9843	0.079	0.874	1.315	0.354	5/16-24UNF	2.7165	0.236	9 750	6 550	2.60
	UC211-202D1LLJ	2.1250													2.46
	UC211-203D1LLJ	2.1875													2.34
60 2 1/4 2 5/16 2 3/8 2 7/16	UC212D1LLJ	60	110	65.1	27	2	25.4	39.7	10	M10×1.25	77	6.2	52 500	36 000	1.53
	UC212-204D1LLJ	2.2500													3.66
	UC212-205D1LLJ	2.3125	4.3307	2.5630	1.0630	0.079	1.000	1.563	0.394	3/8-24UNF	3.0315	0.244	11 800	8 150	3.50
	UC212-206D1LLJ	2.3750													3.33
	UC212-207D1LLJ	2.4375													3.17
65 2 1/2 2 9/16	UC213D1LLJ	65	120	65.1	32	2	25.4	39.7	10	M10×1.25	82.5	8.7	57 500	40 000	1.85
	UC213-208D1LLJ	2.5000	4.7244	2.5630	1.2598	0.079	1.000	1.563	0.394	3/8-24UNF	3.2480	0.343	12 900	9 000	4.26
	UC213-209D1LLJ	2.5625													4.09
70 2 5/8 2 11/16 2 3/4	UC214D1LLJ	70	125	74.6	33	2	30.2	44.4	12	M10×1.25	87	8.8	62 000	44 000	2.10
	UC214-210D1LLJ	2.6250													5.09
	UC214-211D1LLJ	2.6875	4.9213	2.9370	1.2992	0.079	1.189	1.748	0.472	3/8-24UNF	3.4252	0.346	14 000	9 900	4.87
	UC214-212D1LLJ	2.7500													4.65
75 2 13/16 2 7/8 2 15/16 3	UC215D1LLJ	75	130	77.8	34	2	33.3	44.5	12	M10×1.25	93	9.0	66 000	49 500	2.35
	UC215-213D1LLJ	2.8125													5.73
	UC215-214D1LLJ	2.8750	5.1181	3.0630	1.3386	0.079	1.311	1.752	0.472	3/8-24UNF	3.6614	0.354	14 900	11 100	5.49
	UC215-215D1LLJ	2.9375													5.25
	UC215-300D1LLJ	3.0000													4.98
80 3 1/16 3 1/8 3 3/16	UC216D1LLJ	80	140	82.6	35	2.5	33.3	49.3	12	M10×1.25	98.1	9.5	72 500	53 000	2.80
	UC216-301D1LLJ	3.0625													6.57
	UC216-302D1LLJ	3.1250	5.5118	3.2520	1.3780	0.098	1.311	1.941	0.472	3/8-24UNF	3.8622	0.374	16 300	11 900	6.28
	UC216-303D1LLJ	3.1875													6.00
85 3 1/4 3 5/16 3 7/16	UC217D1LLJ	85	150	85.7	36	2.5	34.1	51.6	12	M12×1.5	106.4	10.1	83 500	64 000	3.37
	UC217-304D1LLJ	3.2500													7.92
	UC217-305D1LLJ	3.3125	5.9055	3.3740	1.4173	0.098	1.343	2.031	0.472	1/2-20UNF	4.1890	0.398	18 700	14 300	7.60
	UC217-307D1LLJ	3.4375													6.97
90 3 1/2	UC218D1LLJ	90	160	96	37	2.5	39.7	56.3	12	M12×1.5	111.6	9.8	96 000	71 500	4.36
	UC218-308D1LLJ	3.5000	6.2992	3.7795	1.4570	0.098	1.563	2.217	0.472	1/2-20UNF	4.3937	0.386	21 600	16 100	9.88

1) Minimum allowable dimension for chamfer dimension *r_s*.

Note:

1) For shaft tolerances, see the Bearing Units catalog.

2) The precision of ball bearings is as specified in JIS B 1558 "Ball bearings for rolling bearing units."

3) Contact NTN Engineering for information on tapered bore ball bearings or ball bearings with bores in English measurements.

Triple-sealed ball bearings for bearing unit Type UC3...LLJ

Cylindrical bore with setscrew

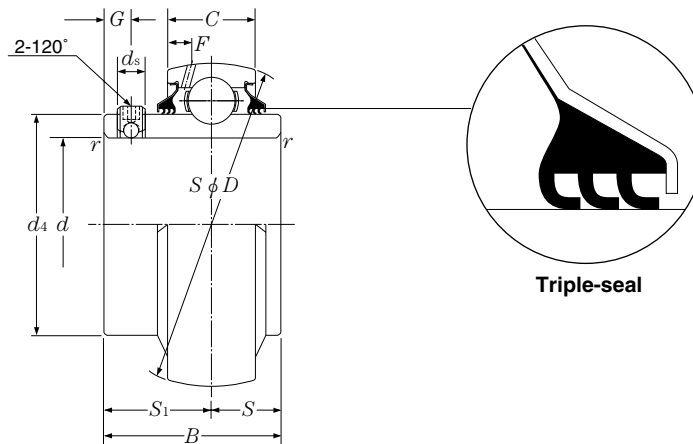

Triple-seal

Shaft dia. mm inch.	Bearing number	Nominal dimensions											Basic load ratings		Mass kg lb
		d	D	B	C	r _s ¹⁾ mm min.	S	S ₁	G	d _s	d ₄	F	N dynamic C _r	lbf static C _{0r}	
25 1 3/16	UC305D1LLJ	25	62	38	20	1.5	15	23	6	M6×0.75	36.8	5.0	21 200	10 900	0.35
13/16	UC305-013D1LLJ	0.8125													0.88
7/8	UC305-014D1LLJ	0.8750	2.4409	1.4961	0.7874	0.059	0.591	0.906	0.236	1/4-28UNF	1.4488	0.197	4 750	2 460	0.84
15/16	UC305-015D1LLJ	0.9375													0.79
1	UC305-100D1LLJ	1.0000													0.77
30 1 1/16	UC306D1LLJ	30	72	43	23	1.5	17	26	6	M6×0.75	44.9	5.9	26 700	15 000	0.56
1 1/8	UC306-101D1LLJ	1.0625													1.34
1 1/8	UC306-102D1LLJ	1.1250	2.8346	1.6929	0.9055	0.059	0.669	1.024	0.236	1/4-28UNF	1.7677	0.232	6 000	3 400	1.28
1 3/16	UC306-103D1LLJ	1.1875													1.23
35 1 1/4	UC307D1LLJ	35	80	48	25	2	19	29	8	M8×1	49.4	6.8	33 500	19 100	0.71
1 1/4	UC307-104D1LLJ	1.2500													1.70
1 5/16	UC307-105D1LLJ	1.3125	3.1496	1.8898	0.9843	0.079	0.748	1.142	0.315	5/16-24UNF	1.9449	0.268	7 500	4 300	1.63
1 3/8	UC307-106D1LLJ	1.3750													1.57
1 7/16	UC307-107D1LLJ	1.4375													1.50
40 1 1/2	UC308D1LLJ	40	90	52	27	2	19	33	10	M10×1.25	56	7.4	40 500	24 000	0.96
1 1/2	UC308-108D1LLJ	1.5000	3.5433	2.0472	1.0630	0.079	0.748	1.299	0.394	3/8-24UNF	2.2047	0.291	9 150	5 400	2.23
1 3/8	UC308-109D1LLJ	1.5625													2.14
45 1 5/8	UC309D1LLJ	45	100	57	29	2	22	35	10	M10×1.25	63.5	7.4	53 000	32 000	1.28
1 5/8	UC309-110D1LLJ	1.6250													3.06
1 11/16	UC309-111D1LLJ	1.6875	3.9370	2.2441	1.1417	0.079	0.866	1.378	0.394	3/8-24UNF	2.5000	0.291	11 900	7 200	2.98
1 3/4	UC309-112D1LLJ	1.7500													2.87
50 1 3/8	UC310D1LLJ	50	110	61	32	2.5	22	39	12	M12×1.5	70.6	8.1	62 000	38 500	1.65
1 3/8	UC310-113D1LLJ	1.8125													3.95
1 7/8	UC310-114D1LLJ	1.8750	4.3307	2.4016	1.2598	0.098	0.866	1.535	0.472	1/2-20UNF	2.7795	0.319	13 900	8 600	3.84
1 5/8	UC310-115D1LLJ	1.9375													3.70
55 2	UC311D1LLJ	55	120	66	34	2.5	25	41	12	M12×1.5	76.6	8.5	71 500	45 000	2.07
2	UC311-200D1LLJ	2.0000													4.96
2 1/16	UC311-201D1LLJ	2.0625	4.7244	2.5984	1.3386	0.098	0.984	1.614	0.472	1/2-20UNF	3.0157	0.335	16 100	10 100	4.81
2 1/8	UC311-202D1LLJ	2.1250													4.67
2 3/16	UC311-203D1LLJ	2.1875													4.50
60 2 1/4	UC312D1LLJ	60	130	71	36	2.5	26	45	12	M12×1.5	82.7	9.0	82 000	52 000	2.60
2 1/4	UC312-204D1LLJ	2.2500													6.06
2 5/16	UC312-205D1LLJ	2.3125	5.1181	2.7953	1.4173	0.098	1.024	1.772	0.472	1/2-20UNF	3.2559	0.354	18 400	11 700	5.89
2 3/8	UC312-206D1LLJ	2.3750													5.68
2 7/16	UC312-207D1LLJ	2.4375													5.51

¹⁾ Minimum allowable dimension for chamfer dimension r.

Note:

1) For shaft tolerances, see the Bearing Units catalog.

2) The precision of ball bearings is as specified in JIS B 1558 "Ball bearings for rolling bearing units."

3) Contact NTN Engineering for information on tapered bore ball bearings or ball bearings with bores in English measurements.

Shaft dia. mm inch.	Bearing number	Nominal dimensions											Basic load ratings		Mass	
		<i>d</i>	<i>D</i>	<i>B</i>	<i>C</i>	<i>r_s</i> ¹⁾ min.	<i>S</i> mm	<i>S</i> inch.	<i>G</i>	<i>d_s</i>	<i>d₄</i>	<i>F</i>	N dynamic <i>C_r</i>	lbf static <i>C_{0r}</i>	kg	lb
65 2½ 2⅝	UC313D1LLJ	65	140	75	39	2.5	30	45	12	M12×1.5	88.2	10.1	92 500	60 000	3.25	
	UC313-208D1LLJ	2.5000	5.5118	2.9528	1.5354	0.098	1.181	1.772	0.472	½-20UNF	3.4724	0.398	20 800	13 400	7.36	
	UC313-209D1LLJ	2.5625													7.14	
70 2⅝ 2⅞ 2¾	UC314D1LLJ	70	150	78	41	2.5	33	45	12	M12×1.5	94.8	10.5	104 000	68 000	3.89	
	UC314-210D1LLJ	2.6250													9.06	
	UC314-211D1LLJ	2.6875	5.9055	3.0709	1.6142	0.098	1.299	1.772	0.472	½-20UNF	3.7323	0.413	23 400	15 300	8.82	
75 2⅞ 2⅞ 3	UC315D1LLJ	75	160	82	43	2.5	32	50	14	M14×1.5	101.3	11.0	113 000	77 000	4.72	
	UC315-213D1LLJ	2.8125													11.0	
	UC315-214D1LLJ	2.8750	6.2992	3.2283	1.6929	0.098	1.260	1.969	0.551	⅝-18UNF	3.9882	0.433	25 500	17 400	10.7	
80 3⅛ 3⅛ 3⅝	UC316D1LLJ	80	170	86	45	2.5	34	52	14	M14×1.5	107.9	11.4	123 000	86 500	5.55	
	UC316-301D1LLJ	3.0625													12.6	
	UC316-302D1LLJ	3.1250	6.6929	3.3858	1.7717	0.098	1.339	2.047	0.551	⅝-18UNF	4.2480	0.449	27 600	19 500	12.3	
85 3¼ 3⅝ 3⅝	UC317D1LLJ	85	180	96	47	3	40	56	16	M16×1.5	114.4	12.0	133 000	97 000	6.67	
	UC317-304D1LLJ	3.2500													15.2	
	UC317-305D1LLJ	3.3125	7.0866	3.7795	1.8504	0.118	1.575	2.205	0.630	⅝-18UNF	4.5039	0.472	29 800	21 800	14.9	
90 3⅞ 3½	UC318D1LLJ	90	190	96	49	3	40	56	16	M16×1.5	120.9	12.3	143 000	107 000	7.56	
	UC318-307D1LLJ	3.4375	7.4803	3.7795	1.9291	0.118	1.575	2.205	0.630	⅝-18UNF	4.7598	0.484	32 000	24 100	17.3	
	UC318-308D1LLJ	3.5000													16.9	
95 3⅝ 3⅞ 3¾	UC319D1LLJ	95	200	103	51	3	41	62	16	M16×1.5	127.5	12.8	153 000	119 000	8.70	
	UC319-310D1LLJ	3.6250													19.9	
	UC319-311D1LLJ	3.6875	7.8740	4.0551	2.0079	0.118	1.614	2.441	0.630	⅝-18UNF	5.0197	0.504	34 500	26 600	19.5	
100 3⅞ 3⅞ 4	UC320D1LLJ	100	215	108	55	3	42	66	18	M18×1.5	135.6	13.5	173 000	141 000	10.8	
	UC320-313D1LLJ	3.8125													24.7	
	UC320-314D1LLJ	3.8750	8.4646	4.2520	2.1654	0.118	1.654	2.598	0.709	⅝-18UNF	5.3386	0.531	39 000	31 500	24.2	
	UC320-315D1LLJ	3.9375													23.8	
	UC320-400D1LLJ	4.0000													23.4	

1) Minimum allowable dimension for chamfer dimension *r_s*.

Note:

- 1) For shaft tolerances, see the Bearing Units catalog.
- 2) The precision of ball bearings is as specified in JIS B 1558 "Ball bearings for rolling bearing units."
- 3) Contact NTN Engineering for information on tapered bore ball bearings or ball bearings with bores in English measurements.

Triple-sealed ball bearings for bearing unit Type UEL3...LLJ

Cylindrical bore with eccentric locking collar

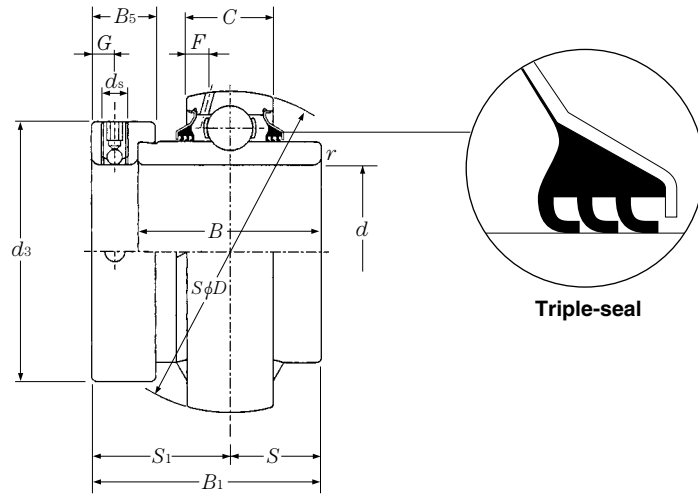

Shaft dia. mm inch	Bearing number	Nominal dimensions													Basic load ratings		Mass kg lb
		<i>d</i>	<i>D</i>	<i>B</i> ₁	<i>B</i>	<i>C</i>	mm <i>r</i> _s ^① min.	<i>S</i>	<i>S</i> ₁	<i>G</i>	<i>d</i> _s	<i>d</i> ₃	<i>B</i> ₅	<i>F</i>	N dynamic <i>C</i> _r	lbf static <i>C</i> _{0r}	
25 1 1/16	UEL305D1LLJ	25	62	46.8	34.9	20	1.5	16.7	30.1	6	M8×1	42.8	15.9	5.0	21 200	10 900	0.43
	UEL305-013D1LLJ	0.8125															1.09
	UEL305-014D1LLJ	0.8750	2.4409	1.843	1.3740	0.7874	0.059	0.657	1.185	0.236	5/16-24UNF	1.685	0.626	0.197	4 750	2 460	1.05
	UEL305-015D1LLJ	0.9375															1.01
1	UEL305-100D1LLJ	1.0000															0.96
30 1 1/16	UEL306D1LLJ	30	72	50	36.5	23	1.5	17.5	32.5	6.7	M8×1	50	17.5	5.9	26 700	15 000	0.69
	UEL306-101D1LLJ	1.0625															1.57
	UEL306-102D1LLJ	1.1250	2.8346	1.969	1.4370	0.9055	0.059	0.689	1.280	0.264	5/16-24UNF	1.969	0.689	0.232	6 000	3 400	1.51
	UEL306-103D1LLJ	1.1875															1.45
35 1 1/4	UEL307D1LLJ	35	80	51.6	38.1	25	2	18.3	33.3	6.7	M8×1	55	17.5	6.8	33 500	19 100	0.80
	UEL307-104D1LLJ	1.2500															1.92
	UEL307-105D1LLJ	1.3125	3.1496	2.031	1.5000	0.9843	0.079	0.720	1.311	0.264	5/16-24UNF	2.165	0.689	0.268	7 500	4 300	1.84
	UEL307-106D1LLJ	1.3750															1.77
	UEL307-107D1LLJ	1.4375															1.69
40 1 1/2	UEL308D1LLJ	40	90	57.1	41.3	27	2	19.8	37.3	8	M10×1.25	63.5	20.6	7.4	40 500	24 000	1.08
	UEL308-108D1LLJ	1.5000	3.5433	2.248	1.6260	1.0630	0.079	0.780	1.469	0.315	3/8-24UNF	2.500	0.811	0.291	9 150	5 400	2.58
	UEL308-109D1LLJ	1.5625															2.49
45 1 7/8	UEL309D1LLJ	45	100	58.7	42.9	29	2	19.8	38.9	8	M10×1.25	70	20.6	7.4	53 000	32 000	1.45
	UEL309-110D1LLJ	1.6250															3.36
	UEL309-111D1LLJ	1.6875	3.9370	2.311	1.6890	1.1417	0.079	0.780	1.531	0.315	3/8-24UNF	2.756	0.811	0.291	11 900	7 200	3.26
	UEL309-112D1LLJ	1.75															3.15
50 1 13/16	UEL310D1LLJ	50	110	66.6	49.2	32	2.5	24.6	42	8.7	M10×1.25	76.2	22.2	8.1	62 000	38 500	1.86
	UEL310-113D1LLJ	1.8125															4.40
	UEL310-114D1LLJ	1.8750	4.3307	2.622	1.9370	1.2598	0.098	0.969	1.654	0.343	3/8-24UNF	3.000	0.874	0.319	13 900	8 600	4.29
	UEL310-115D1LLJ	1.9375															4.15
55 2	UEL311D1LLJ	55	120	73	55.6	34	2.5	27.8	45.2	8.7	M10×1.25	83	22.2	8.5	71 500	45 000	2.34
	UEL311-200D1LLJ	2.0000															5.58
	UEL311-201D1LLJ	2.0625	4.7244	2.874	2.1890	1.3386	0.098	1.094	1.780	0.343	3/8-24UNF	3.268	0.874	0.335	16 100	10 100	5.39
	UEL311-202D1LLJ	2.1250															5.25
	UEL311-203D1LLJ	2.1875															5.08
60 2 1/4	UEL312D1LLJ	60	130	79.4	61.9	36	2.5	30.95	48.45	8.7	M10×1.25	89	23.9	9.0	82 000	52 000	2.94
	UEL312-204D1LLJ	2.2500															6.80
	UEL312-205D1LLJ	2.3125	5.1181	3.126	2.4370	1.4173	0.098	1.219	1.907	0.343	3/8-24UNF	3.504	0.941	0.354	18 400	11 700	6.65
	UEL312-206D1LLJ	2.3750															6.48
	UEL312-207D1LLJ	2.4375															6.19

① Minimum allowable dimension for chamfer dimension *r*.

Note: 1) For shaft tolerances, see Bearing Units catalog.

Shaft dia. mm inch	Bearing number	Nominal dimensions													Basic load ratings		Mass		
		<i>d</i>	<i>D</i>	<i>B</i> ₁	<i>B</i>	<i>C</i>	mm		inch.		<i>G</i>	<i>d</i> _s	<i>d</i> ₃	<i>B</i> ₅	<i>F</i>	N dynamic <i>C</i> _r	lbf static <i>C</i> _{0r}	kg	lb
		<i>r</i> _s ① min.	<i>S</i>	<i>S</i> ₁															
65 2½ 2⅝	UEL313D1LLJ	65	140	85.7	65.1	39	2.5	32.55	53.15	10.3	M12×1.5	97	27	10.1	92 500	60 000	3.67		
	UEL313-208D1LLJ	2.500	5.5118	3.374	2.5630	1.5354	0.098	1.281	2.093	0.406	½-20UNF	3.819	1.063	0.398	20 800	13 400	8.49		
	UEL313-209D1LLJ	2.5625															8.27		
70 2⅝ 2⅞ 2¾	UEL314D1LLJ	70	150	92.1	68.3	41	2.5	34.15	57.95	10.3	M12×1.5	102	30.2	10.5	104 000	68 000	4.40		
	UEL314-210D1LLJ	2.6250															10.4		
	UEL314-211D1LLJ	2.6875	5.9055	3.626	2.6890	1.6142	0.098	1.344	2.281	0.406	½-20UNF	4.016	1.189	0.413	23 400	15 300	10.2		
UEL314-212D1LLJ	2.7500															9.96			
75 2⅞ 2⅞ 2⅞ 3	UEL315D1LLJ	75	160	100	74.6	43	2.5	37.3	62.7	12.7	M16×1.5	113	31.8	11.0	113 000	77 000	5.34		
	UEL315-213D1LLJ	2.8125															13.2		
	UEL315-214D1LLJ	2.8750	6.2992	3.937	2.9370	1.6929	0.098	1.469	2.469	0.500	⅝-18UNF	4.449	1.252	0.433	25 500	17 400	12.9		
	UEL315-215D1LLJ	2.9375															12.7		
UEL315-300D1LLJ	3.0000															12.5			
80 3⅞ 3⅞ 3⅞	UEL316D1LLJ	80	170	106.4	81	45	2.5	40.5	65.9	12.7	M16×1.5	119	31.8	11.4	123 000	86 500	6.70		
	UEL316-301D1LLJ	3.0625															14.9		
	UEL316-302D1LLJ	3.1250	6.6929	4.189	3.1890	1.7717	0.098	1.594	2.594	0.500	⅝-18UNF	4.685	1.252	0.449	27 600	19 500	14.8		
	UEL316-303D1LLJ	3.1875															14.6		
85 3¼ 3⅞ 3⅞	UEL317D1LLJ	85	180	109.5	84.1	47	3	42.05	67.45	12.7	M16×1.5	127	31.8	12.0	133 000	97 000	8.00		
	UEL317-304D1LLJ	3.2500															18.0		
	UEL317-305D1LLJ	3.3125	7.0866	4.311	3.3110	1.8504	0.118	1.656	2.656	0.500	⅝-18UNF	5.000	1.252	0.472	29 800	21 800	17.7		
	UEL317-307D1LLJ	3.4375															17.0		
90 3⅞ 3½	UEL318D1LLJ	90	190	115.9	87.3	49	3	43.65	72.25	14.3	M20×1.5	133	36.5	12.3	143 000	107 000	9.10		
	UEL318-307D1LLJ	3.4375	7.4803	4.563	3.4370	1.9291	0.118	1.719	2.844	0.563	¾-16UNF	5.236	1.437	0.484	32 000	24 100	20.7		
	UEL318-308D1LLJ	3.5000															20.2		
95 3⅞ 3⅞ 3¾	UEL319D1LLJ	95	200	122.3	93.7	51	3	38.9	83.4	14.3	M20×1.5	140	36.5	12.8	153 000	119 000	10.4		
	UEL319-310D1LLJ	3.6250															23.4		
	UEL319-311D1LLJ	3.6875	7.8740	4.815	3.6890	2.0079	0.118	1.531	3.283	0.563	¾-16UNF	5.512	1.437	0.504	34 500	26 600	23.0		
	UEL319-312D1LLJ	3.7500															22.6		
100 3⅞ 3⅞ 3⅞ 4	UEL320D1LLJ	100	215	128.6	100	55	3	50	78.6	14.3	M20×1.5	146	36.5	13.5	173 000	141 000	12.5		
	UEL320-313D1LLJ	3.8125															28.5		
	UEL320-314D1LLJ	3.8750	8.4646	5.063	3.9370	2.1654	0.118	1.969	3.094	0.563	¾-16UNF	5.748	1.437	0.531	39 000	31 500	28.0		
	UEL320-315D1LLJ	3.9375															27.6		
	UEL320-400D1LLJ	4.0000															27.0		

① Minimum allowable dimension for chamfer dimension *r*.
Note: 1) For shaft tolerances, see Bearing Units catalog.

Triple-sealed ball bearings for bearing unit Type REL2...LLJ

Cylindrical bore with eccentric locking collar

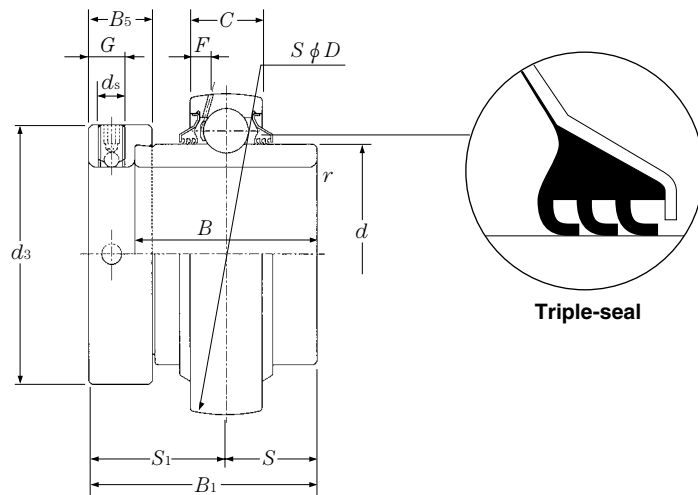

Shaft dia. mm inch	Bearing number ^①	Nominal dimensions													basic load ratings		mass kg lb
		d	D	B ₁	B	C	mm r _s ^② min.	S	S ₁	G	d _s	d ₃	B ₅	F	N dynamic C _r	lbf static C _{0r}	
20 ¾	REL204D1LLJ REL204-012D1LLJ	20 0.7500	47 1.8504	43.7 1.720	34.2 1.3465	15 0.5906	1 0.039	17.1 0.673	26.6 1.047	4.8 0.189	M6×0.75 ¼-28UNF	33 1.299	13.5 0.531	3.2 0.126	12 800 2 890	6 650 1 500	0.22 0.43
25 1⅜ 7/8 15/16 1	REL205D1LLJ REL205-013D1LLJ REL205-014D1LLJ REL205-015D1LLJ REL205-100D1LLJ	25 0.8125 0.8750 0.9375 1.0000	52 2.0472	44.4 1.748	34.9 1.3740	15 0.5906	1 0.039	17.45 0.687	26.9 1.059	4.8 0.189	M6×0.75 ¼-28UNF	38 1.496	13.5 0.531	3.5 0.138	14 000 3 150	7 850 1 770	0.26 0.59 0.56 0.53 0.49
30 1⅛ 1⅝ 1⅜ 1¼	REL206D1LLJ REL206-101D1LLJ REL206-102D1LLJ REL206-103D1LLJ REL206-104D1LLJ	30 1.0625 1.1250 1.1875 1.2500	62 2.4409	48.4 1.906	36.5 1.4370	18 0.7087	1 0.039	18.25 0.719	30.1 1.185	6 0.236	M8×1 ⅝-24UNF	44.5 1.752	15.9 0.626	4.1 0.161	19 500 4 400	11 300 2 540	0.44 0.92 0.87 0.82 0.78
35 1¼ 1⅝ 1⅜ 1⅛	REL207D1LLJ REL207-104D1LLJ REL207-105D1LLJ REL207-106D1LLJ REL207-107D1LLJ	35 1.2500 1.3125 1.3750 1.4375	72 2.8346	51.1 2.012	37.6 1.4803	19 0.7480	1.5 0.059	18.8 0.740	32.3 1.272	6.8 0.268	M10×1.25 ⅜-24UNF	55.5 2.185	17.5 0.689	4.1 0.161	25 700 5 750	15 300 3 450	0.58 1.41 1.36 1.31 1.24
40 1½ 1⅞	REL208D1LLJ REL208-108D1LLJ REL208-109D1LLJ	40 1.5000 1.5625	80 3.1496	56.3 2.217	42.8 1.6850	22 0.8661	1.5 0.059	21.4 0.843	34.9 1.374	6.8 0.268	M10×1.25 ⅜-24UNF	60 2.362	18.3 0.720	4.5 0.177	29 100 6 550	17 800 4 000	0.78 1.88 1.80
45 1⅝ 1⅞ 1¼	REL209D1LLJ REL209-110D1LLJ REL209-111D1LLJ REL209-112D1LLJ	45 1.6250 1.6875 1.7500	85 3.3465	56.3 2.217	42.8 1.6850	22 0.8661	1.5 0.059	21.4 0.843	34.9 1.374	6.8 0.268	M10×1.25 ⅜-24UNF	63.5 2.500	18.3 0.720	4.9 0.193	32 500 7 350	20 400 4 600	0.83 2.01 1.93 1.84
50 1⅞ 1⅝ 1⅞ 2	REL210D1LLJ REL210-113D1LLJ REL210-114D1LLJ REL210-115D1LLJ REL210-200D1LLJ	50 1.8125 1.8750 1.9375 2.0000	90 3.5433	62.7 2.469	49.2 1.9370	22 0.8661	1.5 0.059	24.6 0.969	38.1 1.500	6.8 0.268	M10×1.25 ⅜-24UNF	69.5 2.736	18.3 0.720	4.3 0.169	35 000 7 900	23 200 5 200	0.96 2.42 2.32 2.21 2.05
55 2 2⅛ 2⅝ 2⅞	REL211D1LLJ REL211-200D1LLJ REL211-201D1LLJ REL211-202D1LLJ REL211-203D1LLJ	55 2.0000 2.0625 2.1250 2.1875	100 3.9370	71.4 2.811	55.5 2.1850	24 0.9449	2 0.079	27.75 1.093	43.6 1.717	8 0.315	M10×1.25 ⅜-24UNF	76 2.992	20.7 0.815	4.6 0.181	43 500 9 750	29 200 6 550	1.29 3.21 3.05 2.95 2.83

① These numbers indicate relubricatable type. If maintenance free type is needed, please order without suffix "D1".

② Minimum allowable dimension for chamfer dimension r.

Note: 1) For shaft tolerances, see Bearing Units catalog.

2) UEL series (UEL204~UEL215) are also available with eccentric locking collars.

Shaft dia. mm inch	Bearing number	Nominal dimensions													basic load ratings		mass	
		<i>d</i>	<i>D</i>	<i>B</i> ₁	<i>B</i>	<i>C</i>	mm <i>r</i> _s min.	<i>S</i>	<i>S</i> ₁	<i>G</i>	<i>d</i> _s	<i>d</i> ₃	<i>B</i> ₅	<i>F</i>	N dynamic <i>C</i> _r	lbf static <i>C</i> _{0r}	kg	lb
								inch.										
60 2 ¼	REL212D1LLJ	60	110	77.8	61.9	27	2	30.95	46.8	8	M10×1.25	84	22.3	6.2	52 500	36 000	1.83	4.29
2 ⅝	REL212-204D1LLJ	2.2500																
2 ⅞	REL212-205D1LLJ	2.3125	4.3307	3.063	2.4370	1.0630	0.079	1.219	1.843	0.315	⅜-24UNF	3.307	0.878	0.245	11 800	8 150	4.13	3.96
2 ⅞	REL212-206D1LLJ	2.3750																
2 ⅞	REL212-207D1LLJ	2.4375																
65 2 ½	REL213D1LLJ	65	120	85.7	68.3	27	2	34.15	51.5	8.7	M10×1.25	97	23.8	6.2	57 500	40 000	2.46	5.43
2 ⅝	REL213-208D1LLJ	2.5000	4.7244	3.374	2.6890	1.0630	0.079	1.344	2.028	0.343	⅜-24UNF	3.819	0.937	0.245	12 900	9 000	5.43	5.26
2 ⅝	REL213-209D1LLJ	2.5625																
70 2 ⅞	REL214D1LLJ	70	125	85.7	68.3	28	2	34.15	51.5	8.7	M10×1.25	97	23.8	6.6	62 000	44 000	2.45	5.63
2 ⅞	REL214-210D1LLJ	2.6250																
2 ⅞	REL214-211D1LLJ	2.6875	4.9213	3.374	2.6890	1.1024	0.079	1.344	2.028	0.343	⅜-24UNF	3.819	0.937	0.260	14 000	9 900	5.41	5.14
2 ⅞	REL214-212D1LLJ	2.7500																
75 2 ⅞	REL215D1LLJ	75	130	92.0	74.6	29	2	37.3	54.7	8.7	M10×1.25	102	23.8	6.5	66 000	49 500	2.66	6.35
2 ⅞	REL215-213D1LLJ	2.8125																
2 ⅞	REL215-214D1LLJ	2.8750	5.1181	3.622	2.9370	1.1417	0.079	1.469	2.154	0.343	⅜-24UNF	4.016	0.937	0.256	14 900	11 100	6.11	5.87
2 ⅞	REL215-215D1LLJ	2.9375																
3	REL215-300D1LLJ	3.0000																

Farm implement bearings

Ball bearing, square bore, spherical O.D.

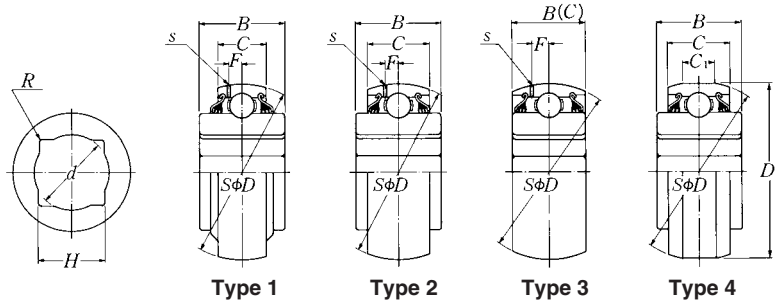

Shaft dia. inch	Bearing number	Type	Nominal dimensions											Basic load ratings		Mass kg lb		
														N	lbf			
			H	d max.	R max.	D	mm		inch.		B	D ₁	C ₁	s	F		C _r	C _{or}
7/8	1AS08-7/8	1	22.987±0.127	24.4	2.25	80	0	18	0	36.5	0	—	—	—	—	29 100	17 800	0.73
			0.9050±0.0050	0.961	0.089	3.1496	-0.013	0.7087	-0.12	0	-0.0047	—	—	—	—	6 550	4 000	1.61
7/8	4AS08-7/8	4	22.987±0.127	24.4	2.25	87.338	0	30.2	0	36.5	0	85.750	0	16.6	—	29 100	17 800	0.93
			0.9050±0.0050	0.961	0.089	3.4385	-0.025	1.1890	-0.12	0	-0.0047	3.3760	-0.025	0.6535	—	6 550	4 000	2.05
1	1AS08-1	1	26.162±0.127	27.8	2.25	80	0	18	0	36.5	0	—	—	—	—	29 100	17 800	0.68
			1.0300±0.0050	1.095	0.089	3.1496	-0.013	0.7087	-0.12	0	-0.0047	—	—	—	—	6 550	4 000	1.50
1	2AS08-1D1	2	26.162±0.127	27.8	2.25	80	0	30.2	0	36.5	0	—	—	2.2	6.6	29 100	17 800	0.76
			1.0300±0.0050	1.095	0.089	3.1496	-0.013	1.1890	-0.12	0	-0.0047	—	—	0.087	0.260	6 550	4 000	1.68
1	4AS08-1	4	26.162±0.127	27.8	2.25	87.338	0	30.2	0	36.5	0	85.750	0	16.6	—	29 100	17 800	0.89
			1.0300±0.0050	1.095	0.089	3.4385	-0.025	1.1890	-0.12	0	-0.0047	3.3760	-0.025	0.6535	—	6 550	4 000	1.96
1 1/8	1AS08-1 1/8	1	29.972±0.127	31.4	2.25	80	0	18	0	36.5	0	—	—	—	—	29 100	17 800	0.60
			1.1800±0.0050	1.236	0.089	3.1496	-0.013	0.7087	-0.12	0	-0.0047	—	—	—	—	6 550	4 000	1.32
1 1/8	2AS08-1 1/8 D1	2	29.972±0.127	31.4	2.25	80	0	30.2	0	36.5	0	—	—	2.2	6.6	29 100	17 800	0.70
			1.1800±0.0050	1.236	0.089	3.1496	-0.013	1.1890	-0.12	0	-0.0047	—	—	0.087	0.260	6 550	4 000	1.54
1 1/8	4AS08-1 1/8	4	29.972±0.127	31.4	2.25	87.338	0	30.2	0	36.5	0	85.750	0	16.6	—	29 100	17 800	0.90
			1.1800±0.0050	1.236	0.089	3.4385	-0.025	1.1890	-0.12	0	-0.0047	3.3760	-0.025	0.6535	—	6 550	4 000	1.99
1 5/32	1AS08-1 5/32 D1	1	30±0.127	31.8	2.25	80	0	21	0	36.5	0	—	—	2.2	6.6	29 100	17 800	0.64
			1.1811±0.0050	1.252	0.089	3.1496	-0.013	0.8268	-0.12	0	-0.0047	—	—	0.087	0.260	6 550	4 000	1.41
1 1/4	2AS09-1 1/4 D1	2	32.766±0.127	34.8	2.25	85	0	30.2	0	36.5	0	—	—	2.2	6.7	32 500	20 400	0.77
			1.2900±0.0050	1.370	0.089	3.3465	-0.015	1.1890	-0.120	0	-0.0047	—	—	0.087	0.264	7 350	4 600	1.70
1 1/4	4AS09-1 1/4	4	32.766±0.127	34.8	2.25	87.338	0	30.2	0	36.5	0	85.750	0	16.6	—	32 500	20 400	0.82
			1.2900±0.0050	1.370	0.089	3.4385	-0.025	1.1890	-0.12	0	-0.0047	3.3760	-0.025	0.6535	—	7 350	4 600	1.81
1 1/8	2AS10-1 1/8 D1	2	29.972±0.127	31.4	2.25	90	0	30.2	0	36.5	0	—	—	2.2	6.7	35 000	23 200	0.98
			1.1800±0.0050	1.236	0.089	3.5433	-0.015	1.1890	-0.12	0	-0.0047	—	—	0.087	0.264	7 900	5 200	2.16
1 1/8	3AS10-1 1/8 D1	3	29.972±0.127	31.4	2.25	90	0	30.2	0	30.2	0	—	—	2.2	6.7	35 000	23 200	0.88
			1.1800±0.0050	1.236	0.089	3.5433	-0.015	1.1890	-0.12	0	-0.0047	—	—	0.087	0.264	7 900	5 200	1.94
1 1/2	1AS11-1 1/2 D1	1	38.89±0.127	41.2	2.25	100	0	25	0	44.45	0	—	—	2.5	7.6	43 500	29 200	1.19
			1.5311±0.0050	1.622	0.089	3.9370	-0.015	0.9843	-0.15	0	-0.0059	—	—	0.098	0.299	9 750	6 550	2.63
1 1/2	3AS11-1 1/2 D1	3	38.89±0.127	41.2	2.25	100	0	33.3	0	33.3	0	—	—	2.5	7.6	43 500	29 200	1.10
			1.5311±0.0050	1.622	0.089	3.9370	-0.015	1.3110	-0.15	0	-0.0059	—	—	0.098	0.299	9 750	6 550	2.43
1 1/2	4AS11-1 1/2	4	38.89±0.127	41.2	2.25	104.725	0	36.5	0	44.45	0	103.556	0	15.9	—	43 500	29 200	1.48
			1.5311±0.0050	1.622	0.089	4.1230	-0.025	1.4370	-0.15	0	-0.0059	4.0770	-0.025	0.6142	—	9 750	6 550	3.26
2	3AS14-2D1	3	52.2±0.127	54.9	4.0	125	0	39.69	0	39.69	0	—	0.6260	3.0	9.4	62 000	44 000	1.90
			2.0551±0.0050	2.161	0.157	4.9213	-0.020	1.5626	-0.15	0	-0.0059	—	—	0.118	0.370	14 000	9 900	4.19

Remarks: 1) Bearings suffixed with D1 have oil holes on the outer ring.
2) R min.: 0.059 inch except 3AS14-2D1 R min.: 0.118 inch.

Ball bearing, square bore, cylindrical O.D.

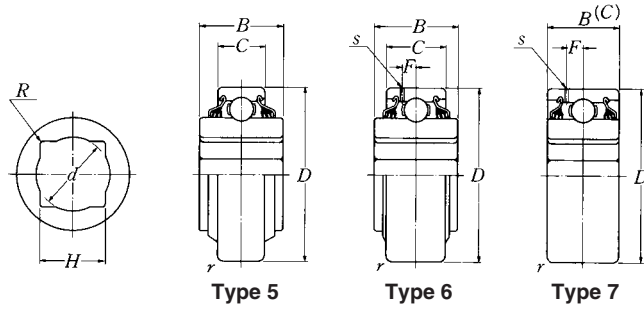

Shaft dia. inch	Bearing number	Type	Nominal dimensions											Basic load ratings		Mass kg lb	
			<i>H</i>	<i>d</i> max.	<i>R</i> max.	<i>D</i>	mm		inch.		<i>B</i>	<i>r_s</i>	<i>s</i>	<i>F</i>	N dynamic <i>C_r</i>		lbf static <i>C_{or}</i>
1	5AS08-1	5	26.162 ±0.127	27.8	2.25	80	0 -0.013	18	0 -0.12	36.5	0 -0.12	1.5	—	—	29 100	17 800	0.66
			1.0300 ±0.0050	1.095	0.089	3.1496	0 -0.0005	0.7087	0 -0.0047	1.4370	0 -0.0047	0.059	—	—	6 550	4 000	1.46
1	6AS08-1D1	6	26.162 ±0.127	27.8	2.25	80	0 -0.013	30.2	0 -0.12	36.5	0 -0.12	1.5	2.2	6.6	29 100	17 800	0.78
			1.0300 ±0.0050	1.095	0.089	3.1496	0 -0.0005	1.1890	0 -0.0047	1.4370	0 -0.0047	0.059	0.087	0.260	6 550	4 000	1.72
1 1/8	5AS08-1. 1/8	5	29.972 ±0.127	31.4	2.25	80	0 -0.013	18	0 -0.12	36.5	0 -0.12	1.5	—	—	29 100	17 800	0.61
			1.1800 ±0.0050	1.236	0.089	3.1496	0 -0.0005	0.7087	0 -0.0047	1.4370	0 -0.0047	0.059	—	—	6 550	4 000	1.35
1 1/8	6AS08-1. 1/8D1	6	29.972 ±0.127	31.4	2.25	80	0 -0.013	30.2	0 -0.12	36.5	0 -0.12	1.5	2.2	6.6	29 100	17 800	0.73
			1.1800 ±0.0050	1.236	0.089	3.1496	0 -0.0005	1.1890	0 -0.0047	1.4370	0 -0.0047	0.059	0.087	0.260	6 550	4 000	1.61
1 1/8	7AS10-1. 1/8D1	7	29.972 ±0.127	31.4	2.25	90	0 -0.015	30.2	0 -0.12	30.2	0 -0.12	1.5	2.2	6.7	35 000	23 200	0.90
			1.1800 ±0.0050	1.236	0.089	3.5433	0 -0.0006	1.1890	0 -0.0047	1.1890	0 -0.0047	0.059	0.087	0.264	7 900	5 200	1.99
1 1/2	7AS11-1. 1/2D1	7	38.89 ±0.127	41.2	2.25	100	0 -0.015	33.3	0 -0.15	33.3	0 -0.15	2	2.5	7.6	43 500	29 200	1.12
			1.5311 ±0.0050	1.622	0.089	3.9370	0 -0.0006	1.3110	0 -0.0059	1.3110	0 -0.0059	0.079	0.098	0.299	9 750	6 550	2.47

Remarks: 1) Bearings suffixed with D1 have oil holes on the outer ring.
2) *R* min.: 0.059 inch.

Farm implement bearings

Ball bearing, round bore, spherical O.D.

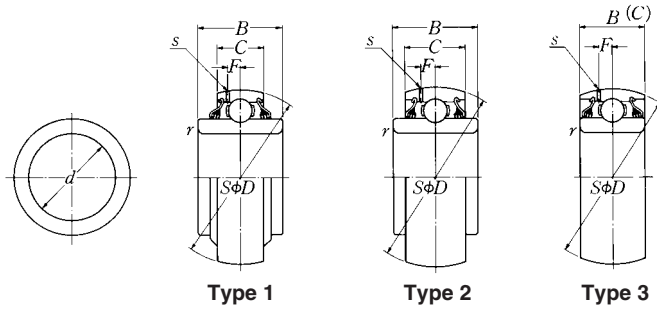

Shaft dia. inch	Bearing number	Type	Nominal dimensions									basic load ratings		mass kg lb
			d	D	mm		inch.		r_s min.	s	F	N dynamic C_r	lbf static C_{or}	
1 $\frac{3}{16}$	1AC08-1.3 $\frac{1}{16}$	1	30.175 ⁰ _{-0.013}	80 ⁰ _{-0.013}	18 ⁰ _{-0.12}	30.2 ⁰ _{-0.12}	30.2 ⁰ _{-0.12}	1.5	—	—	29 100	17 800	0.61	
			1.1880 ⁰ _{-0.0005}	3.1496 ⁰ _{-0.0005}	0.7087 ⁰ _{-0.0047}	1.1890 ⁰ _{-0.0047}	0.059	—	—	6 550	4 000	1.35		
1.7717	3AC09D1	3	45 ⁰ _{-0.013}	85 ⁰ _{-0.015}	30.2 ⁰ _{-0.12}	30.2 ⁰ _{-0.12}	30.2 ⁰ _{-0.12}	1.5	2.2	6.7	32 500	20 400	0.59	
			1.7717 ⁰ _{-0.0005}	3.3465 ⁰ _{-0.0006}	1.1890 ⁰ _{-0.0047}	1.1890 ⁰ _{-0.0047}	0.059	0.087	0.264	7 350	4 600	1.30		
1 $\frac{1}{2}$	3AC09-1.1 $\frac{1}{2}$ D1	3	38.989 ⁰ _{-0.254}	85 ⁰ _{-0.015}	30.2 ⁰ _{-0.12}	30.2 ⁰ _{-0.12}	30.2 ⁰ _{-0.12}	1.5	2.2	6.7	32 500	20 400	0.68	
			1.5350 ⁰ _{-0.0100}	3.3465 ⁰ _{-0.0006}	1.1890 ⁰ _{-0.0047}	1.1890 ⁰ _{-0.0047}	0.059	0.087	0.264	7 350	4 600	1.50		
1 $\frac{3}{4}$	3AC10-1.3 $\frac{1}{4}$ D1	3	45.339 ⁰ _{-0.254}	90 ⁰ _{-0.015}	30.2 ⁰ _{-0.12}	30.2 ⁰ _{-0.12}	30.2 ⁰ _{-0.12}	1.5	2.2	6.7	35 000	23 200	0.70	
			1.7850 ⁰ _{-0.0100}	3.5433 ⁰ _{-0.0006}	1.1890 ⁰ _{-0.0047}	1.1890 ⁰ _{-0.0047}	0.059	0.087	0.264	7 900	5 200	1.54		
1 $\frac{15}{16}$	3AC10-1.15 $\frac{1}{16}$ D1	3	49.225 ⁰ _{-0.013}	90 ⁰ _{-0.015}	30.2 ⁰ _{-0.12}	30.2 ⁰ _{-0.12}	30.2 ⁰ _{-0.12}	1.5	2.2	6.7	35 000	23 200	0.65	
			1.9380 ⁰ _{-0.0005}	3.5433 ⁰ _{-0.0006}	1.1890 ⁰ _{-0.0047}	1.1890 ⁰ _{-0.0047}	0.059	0.087	0.264	7 900	5 200	1.43		
2 $\frac{3}{16}$	3AC11-2.3 $\frac{1}{16}$ D1	3	55.575 ⁰ _{-0.015}	100 ⁰ _{-0.015}	33.3 ⁰ _{-0.15}	33.3 ⁰ _{-0.15}	33.3 ⁰ _{-0.15}	2	2.5	7.6	43 500	29 200	0.87	
			2.1880 ⁰ _{-0.0006}	3.9370 ⁰ _{-0.0006}	1.3110 ⁰ _{-0.0059}	1.3110 ⁰ _{-0.0059}	0.079	0.098	0.299	9 750	6 550	1.92		
2.7559	3AC14D1	3	70 ⁰ _{-0.015}	125 ⁰ _{-0.020}	39.69 ⁰ _{-0.15}	39.69 ⁰ _{-0.15}	39.69 ⁰ _{-0.15}	2	3.0	9.4	62 000	44 000	1.56	
			2.7559 ⁰ _{-0.0006}	4.9213 ⁰ _{-0.0008}	1.5626 ⁰ _{-0.0059}	1.5626 ⁰ _{-0.0059}	0.079	0.118	0.370	14 000	9 900	3.44		
1 $\frac{15}{16}$	3AC14-1.15 $\frac{1}{16}$ D1	3	49.225 ⁰ _{-0.015}	125 ⁰ _{-0.020}	39.69 ⁰ _{-0.15}	39.69 ⁰ _{-0.15}	39.69 ⁰ _{-0.15}	2	3.0	9.4	62 000	44 000	2.20	
			1.9380 ⁰ _{-0.0006}	4.9213 ⁰ _{-0.0008}	1.5626 ⁰ _{-0.0059}	1.5626 ⁰ _{-0.0059}	0.079	0.118	0.370	14 000	9 900	4.85		

Remarks: 1) Bearings suffixed with D1 have oil holes on the outer ring.

Ball bearing, round bore, cylindrical O.D.

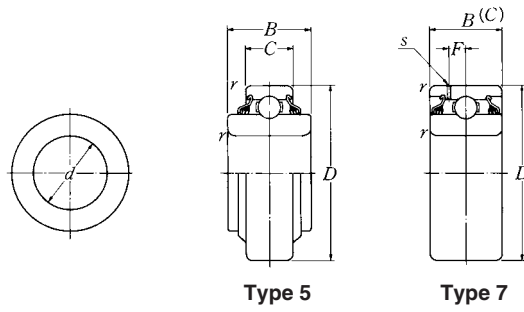

Shaft dia. inch	Bearing number	Type	Nominal dimensions										Basic load ratings		Mass kg lb
			<i>d</i>	<i>D</i>	mm		inch.		<i>r_s</i> min.	<i>s</i>	<i>F</i>	N dynamic <i>C_r</i>	lbf static <i>C_{0r}</i>		
1.1811	5AC06	5	30	62	16	25.4	0	0	1	—	—	19 500	11 300	0.21	
			0 -0.010	0 -0.013	0 -0.12	0 -0.12	0 -0.047	0 -0.047	0.039	—	—	4 400	2 540	0.46	
1 ¹⁵ / ₁₆	5AC10-1. ¹⁵ / ₁₆	5	49.225	90	20	49.2	0	0	1.5	—	—	35 000	23 200	0.74	
			0 -0.013	0 -0.015	0 -0.12	0 -0.12	0 -0.047	0 -0.047	0.059	—	—	7 900	5 200	1.63	
1 ¹³ / ₃₂	7AC10-1. ¹³ / ₃₂ D1	7	35.725	90	30.2	30.2	0	0	1.5	2.2	6.7	35 000	23 200	0.88	
			0 -0.013	0 -0.015	0 -0.12	0 -0.12	0 -0.047	0 -0.047	0.059	0.087	0.264	7 900	5 200	1.94	
1 ¹⁵ / ₁₆	7AC10-1. ¹⁵ / ₁₆ D1	7	49.225	90	30.2	30.2	0	0	1.5	2.2	6.7	35 000	23 200	0.68	
			0 -0.013	0 -0.015	0 -0.12	0 -0.12	0 -0.047	0 -0.047	0.059	0.087	0.264	7 900	5 200	1.50	
2 ³ / ₁₆	7AC11-2. ³ / ₁₆ D1	7	55.575	100	33.3	33.3	0	0	2	2.5	7.6	43 500	29 200	0.91	
			0 -0.015	0 -0.015	0 -0.15	0 -0.15	0 -0.059	0 -0.059	0.079	0.098	0.299	9 750	6 550	2.01	

Remarks: 1) Bearings suffixed with D1 have oil holes on the outer ring.