



Leadshine

Stock Code: 002979



AC Servo

Product Catalogue

www.leadshine.com

Reliable Motion Control Partner

Contents

• Page Index	01-10
Company Profile Product System Servo Product Servo Products Quick Selection Typical Industry Applications	
• AC Servo Drives	11-56
EL8 Series AC Servo Drives • EL8-EC • EL8-RS • EL8-L EL7 Series AC Servo Drives • EL7-RS • EL7-EC • EL7-PN EL6 Series AC Servo Drives • EL6-RS • EL6-CAN	
• AC Servo Motors	57-87
ELM1 Series ELM2 Series	



● **Headquarters in Shenzhen**



● **Shanghai Intelligent Industry Park**



● **Production base in Shenzhen**

- **Founded in 1997**
- **Public Listed Company in China (002979.SZ)**
- **Dedication in Motion Control**
Stepper/Servo systems, Motion Controllers, PLC
Control systems, I/O Modules, Encoders
- **A leading supplier of motion control products and solutions in the world**
- **Customer Oriented, Technology Oriented, Forever Improving, Sharing of Success**

25+ Experience 400+ R&D Engineers 5 Subsidiaries 60+ Countries Clients 10000+ Global Partners 30million+ Installed Axes

Leadshine Motion Control Total Product System

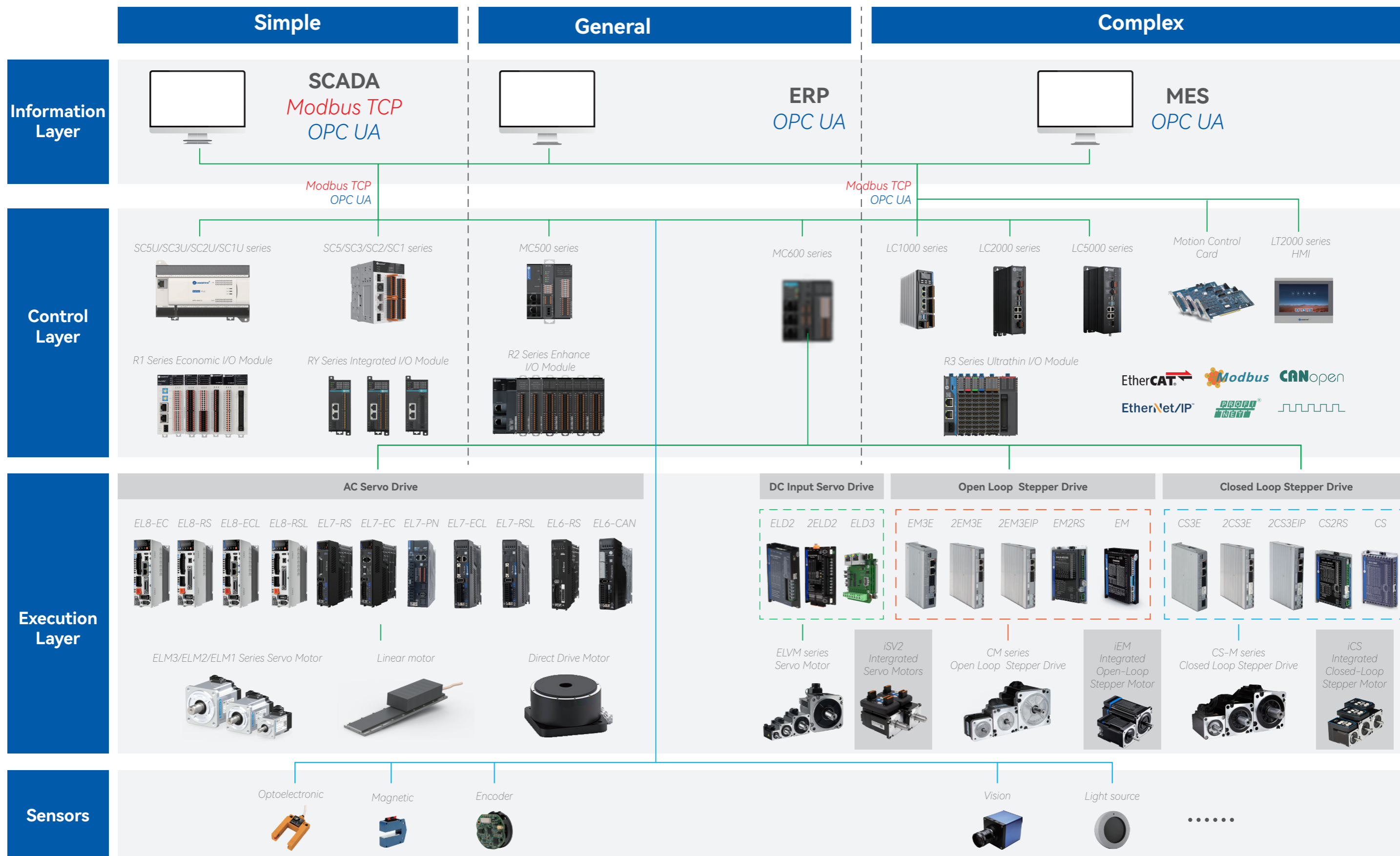

Leadshine Servo Product

● Servo Drive Series

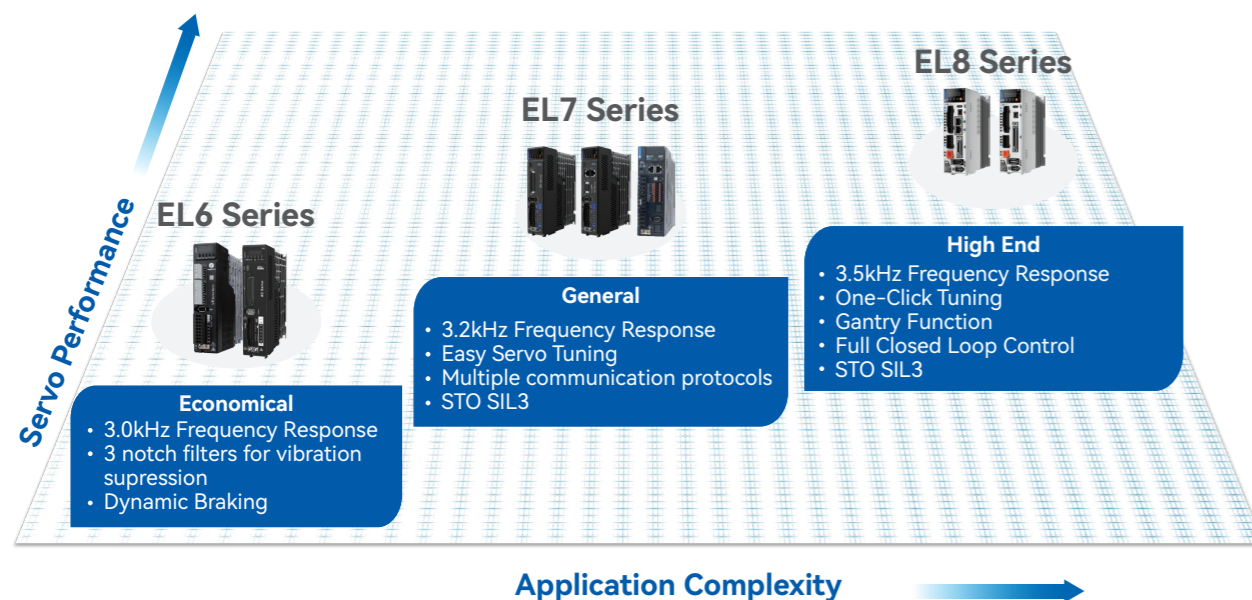

● Servo Motor Series

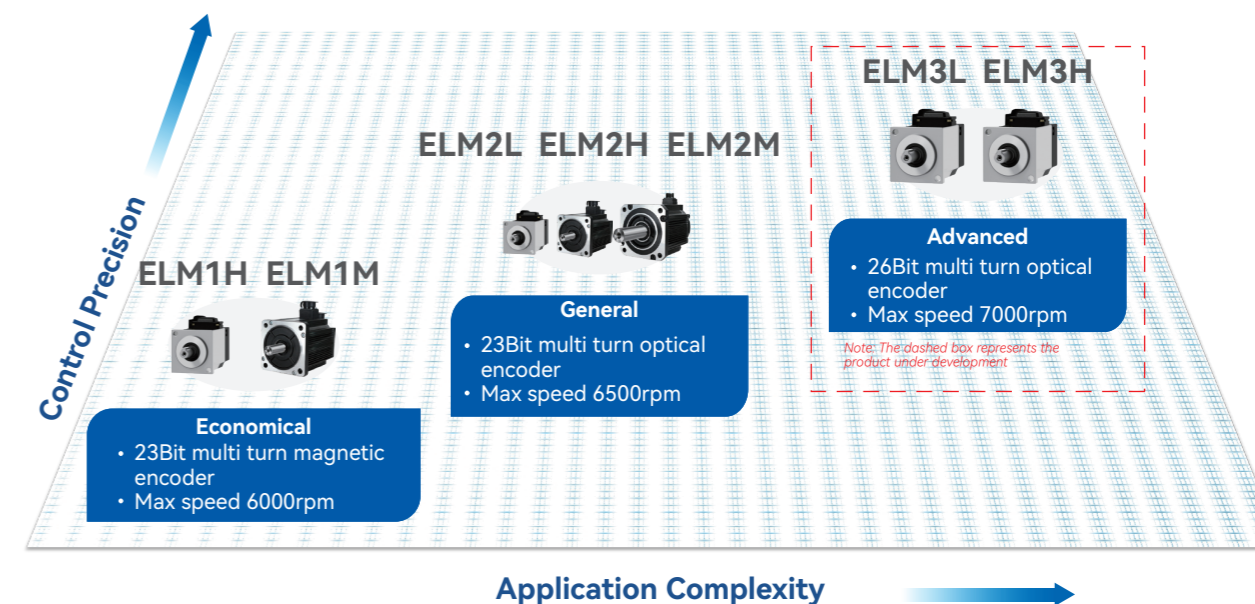

● Typical Applications

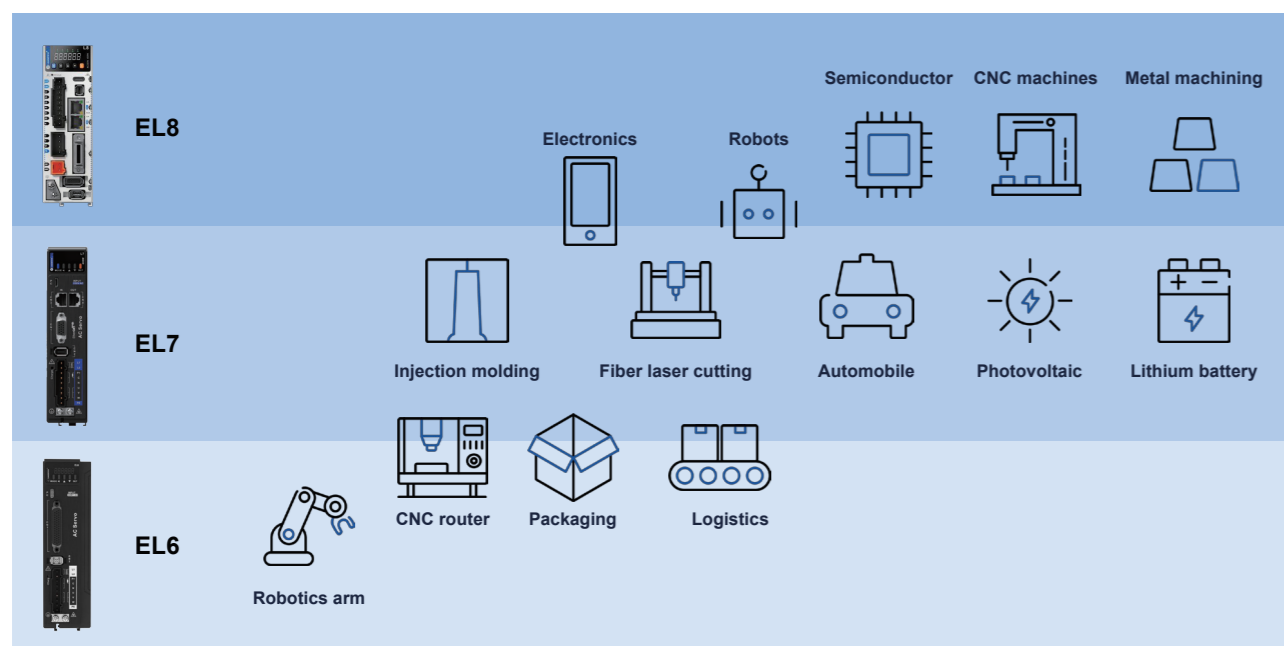

● Simple Introduction

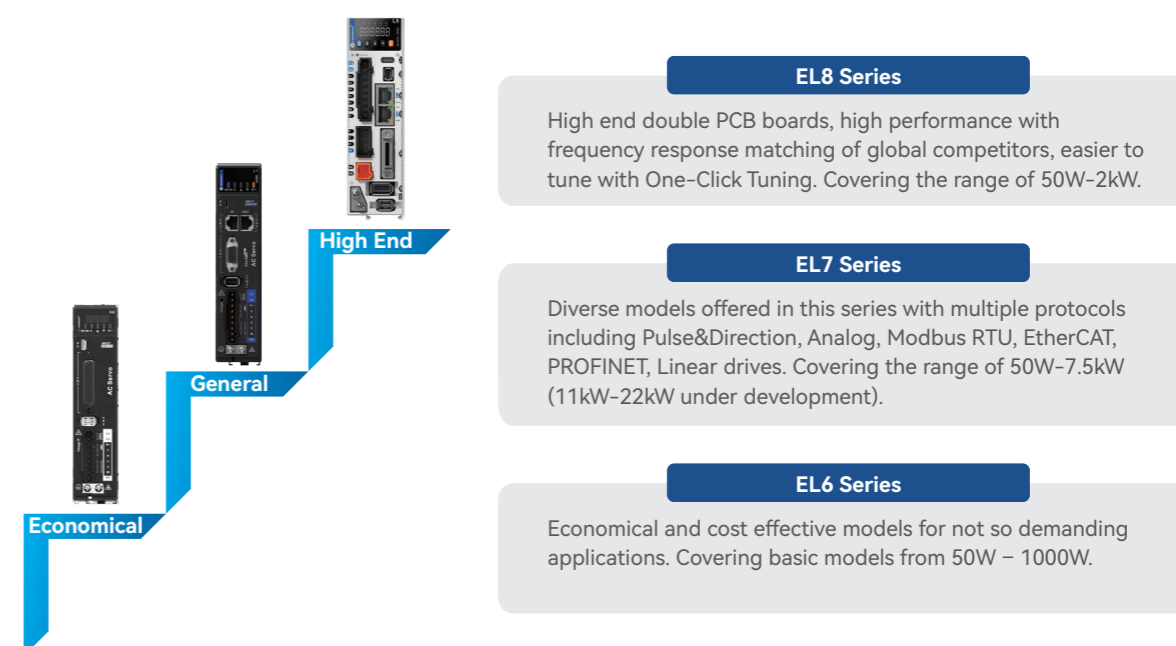

Leadshine Servo Products Quick Selection

Servo Drive	Model	Power (W)	Voltage (VAC)	Dimensions (mm)	Weight (kg)	Command Source		Command Source			STO	Encoder Output	Brake Output	Digital Inputs (Points)	Digital Outputs (Points)	Analogue Input	Analogue Output	Matched Servo Motors
						Pulse+Dir	Analog Input	RS485	EtherCAT	CANopen								
AC Servo Drive EL8 Series	EL8-EC400F	400	1 Phase/ 3 Phase 220	150*150*43	1						√	√		8	3	2	2	
	EL8-RS400F									√	√	√	10	6	3	2		
	EL8-EC750F	750		150*160*55	1.2	√	√		√			√	8	3	2	2		
	EL8-RS750F							√	√	√	√	√	10	6	3	2		
	EL8-EC1000F	1000		183*160*80	2						√	√	√	8	3	2	2	
	EL8-RS1000F							√	√	√	√	√	10	6	3	2		
	EL8-EC1500F	1500		183*160*80	2						√	√		8	3	2	2	
	EL8-RS1500F							√	√	√	√	√	10	6	3	2		
	EL8-EC2000F	2000		183*160*80	2						√	√	√	8	3	2	2	
EL8-RS2000F						√	√	√	√	√	10	6	3	2				
AC Servo Drive EL7 Series - 220VAC	EL7-RS400P	400	1 Phase 220	175*156*40	0.9	√	√		√			√		8	5	2	1	ELM1 and ELM2 Servo Motors Please refer to page 84 to 87 for more information on matching servo motors
	EL7-RS750P	750		175*156*50	1.1	√	√		√			√		8	5	2	1	
	EL7-RS1000P	1000		175*156*50	1.2	√	√		√			√		8	5	2	1	
	EL7-RS1500P	1500	1 Phase/ 3 Phase 220	175*156*80	2.3	√	√		√			√		8	5	2	1	
	EL7-RS2000P	2000			2.3	√	√		√			√		8	5	2	1	
AC Servo Drive EL7 Series - 400VAC	EL7-RS750PT	750	3 Phase 400	179*175*55	1.3	√	√		√			√		8	5	2	1	
	EL7-RS1000PT	1000				√	√		√			√		8	5	2	1	
	EL7-RS1500PT	1500				√	√		√			√		8	5	2	1	
	EL7-RS2000PT	2000		179*175*80	1.9	√	√		√			√		8	5	2	1	
	EL7-RS3000PT	3000				√	√		√			√		8	5	2	1	
	EL7-RS4400PT	4400		230*250*90	3.3	√	√		√			√		8	5	2	1	
	EL7-RS5500PT	5500				√	√		√			√		8	5	2	1	
	EL7-RS7500PT	7500				√	√		√			√		8	5	2	1	
AC Servo Drive EL7 Series - 220VAC	EL7-EC400N	400	1 Phase 220	175*156*40	0.9					√	√		4	3				
	EL7-EC750N	750		175*156*50	1.2					√	√		4	3				
	EL7-EC1000N	1000	1 Phase/ 3 Phase 220	179*175*55	2.3					√	√		4	3				
	EL7-EC1500N	1500				√	√		4	3								
	EL7-EC2000N	2000				√	√		4	3								
AC Servo Drive EL7 Series - 400VAC	EL7-EC750NT	750	3 Phase 400	179*175*55	1.3					√	√		4	3				
	EL7-EC1000NT	1000				√	√		4	3								
	EL7-EC1500NT	1500				√	√		4	3								
	EL7-EC2000NT	2000		179*175*80	1.9	√	√		√	√		4	3					
	EL7-EC3000NT	3000				√	√		4	3								
	EL7-EC4400NT	4400		230*250*90	3.3	√	√		√	√		4	3					
	EL7-EC5500NT	5500				√	√		4	3								
	EL7-EC7500NT	7500				√	√		4	3								
AC Servo Drive EL6 Series	EL6-RS400P	400	1 Phase 220	175*156*40	0.9	√			√				8	5				
	EL6-CAN400Z										√			4	3			
	EL6-RS750P	750		175*156*50	1.1	√			√			√		8	5			
	EL6-CAN750Z												4	3				
	EL6-RS1000P	1000		175*156*50	1.2	√			√			√		8	5			
	EL6-CAN1000Z												4	3				

Applications

CNC Router



Product Advantages:

- High torque servo motor with 3 times overloading capability
- 23-bit encoders with great impact resistant and harsh environment resistance
- Servo drive optimized for CNC router applications
- Comes with safety features such as Safe Torque Off and Dynamic Braking
- Servo Motors maximum torque ranging from 0.105Nm up to 119Nm

Fiber Laser Cutting

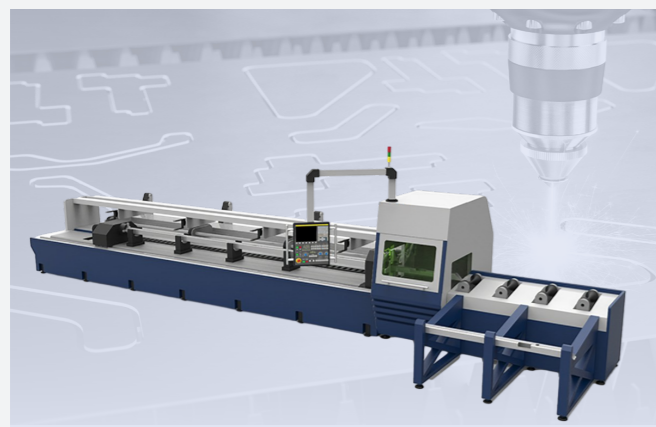

Product Advantages:

- Great Compatibility with renowned laser cutting controller from FScut, Weihong, Beckhoff, Empower, etc.
- Available with most mainstream communication protocols (EtherCAT, Modbus RTU, PROFINET)
- Accurate positioning of 0.02mm and precision up to 0.01mm
- Easy servo tuning features to assist users in setting up the servo systems
- Robust and compact servo motors with high dust- and waterproof ratings



Wafer Cutting

- Full Closed Loop Control function to realize high accuracy control and real time compensation for lead screw wear.
- Real time control using EtherCAT/PROFINET servo drives.
- Easy-to-use, low maintenance and high reliability.



Automated Battery Lamination

- Linear Motors, Direct Drive Motors and Rotary Servo Motors are available.
- Production cycle time per part as low as 0.55s.
- High accuracy and precision motion control with servo drive frequency response of 3.5kHz



Semiconductor Wafer Cleaning

- High following capability with servo frequency response up to 3.5kHz
- Easy servo tuning features for notch filter settings and anti-vibration tunings
- Industrial Ethernet Standard with communication rate up to 100Mbps and compatible with any mainstream PLCs.

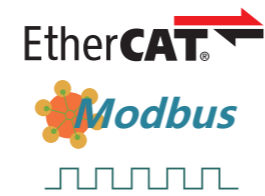

High End AC Servo Drives

EL8 Series

EL8 Series AC Servo Drives are our latest high end servo drives which are packed with a whole lot more new hardware and software features. This series of servo drive also comes with another version which combines analogue control, Modbus RTU protocol (RS485) and pulse + direction control into one. We added STO SIL3, analogue I/Os, holding brake port and EL8 series now supports a 2nd external encoder as well with our full closed loop control.



Robotic Arm



Precise Machining



Semiconductor



Electronics



Fiber Laser

Overview

Quick Frequency Response

Frequency response of 3.5kHz, quicker system response and better precision.

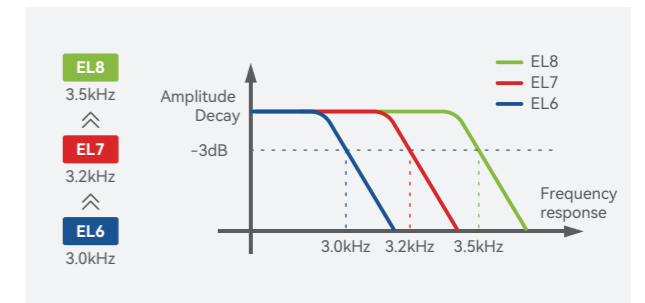

Full closed loop control

EL8 series servo drives support full closed loop control which can eliminate the position deviation due to mechanical gap, and precision will have an obvious improvement.

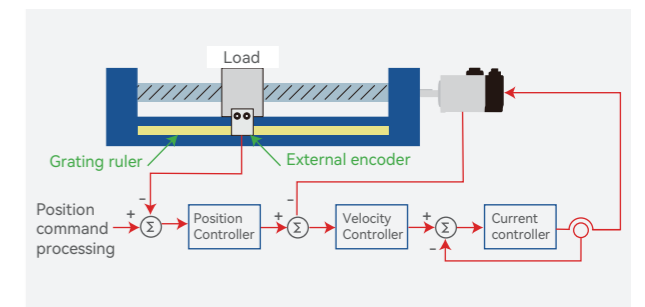

Gantry synchronization

Gantry synchronization MIMO technique, breaking through foreign technological barrier.

EL8 series servo drive is able to realize axis synchronization and alignment automatically without input from master device.

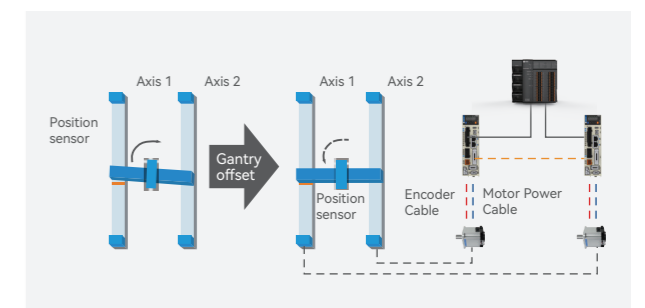

Safe Torque Off (SIL3)

When Safe Torque Off is activated, internal circuit will cut off motor power supply immediately, guaranteeing operator and machine safety.

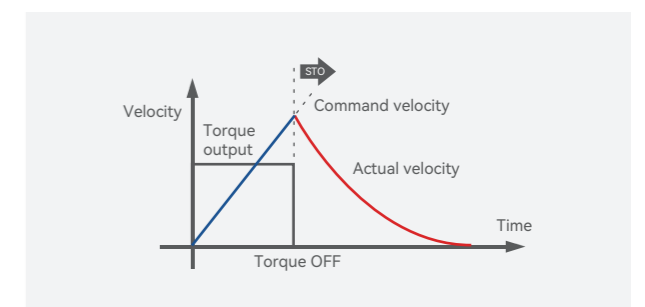

Part Numbers

EL8 - EC 400 F

Series Num		Version	
EL8	EL8 series	F	Full Functions

Command Source		Version			
EC	EtherCAT	400	400W	750	750W
RS	Modbus RTU/ Analog Input/ Pulse+Direction	1000	1000W	1500	1500W
		2000	2000W		

Ports & Connectors

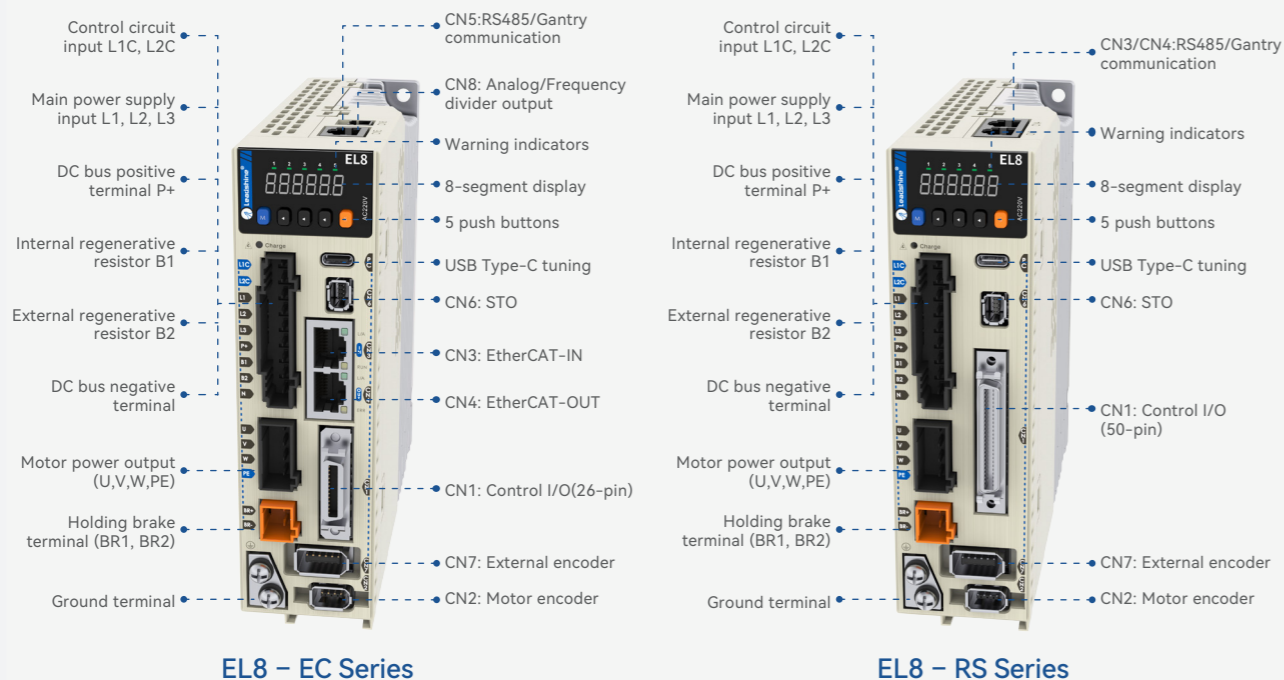

400W (AC 220V)

Unit: mm

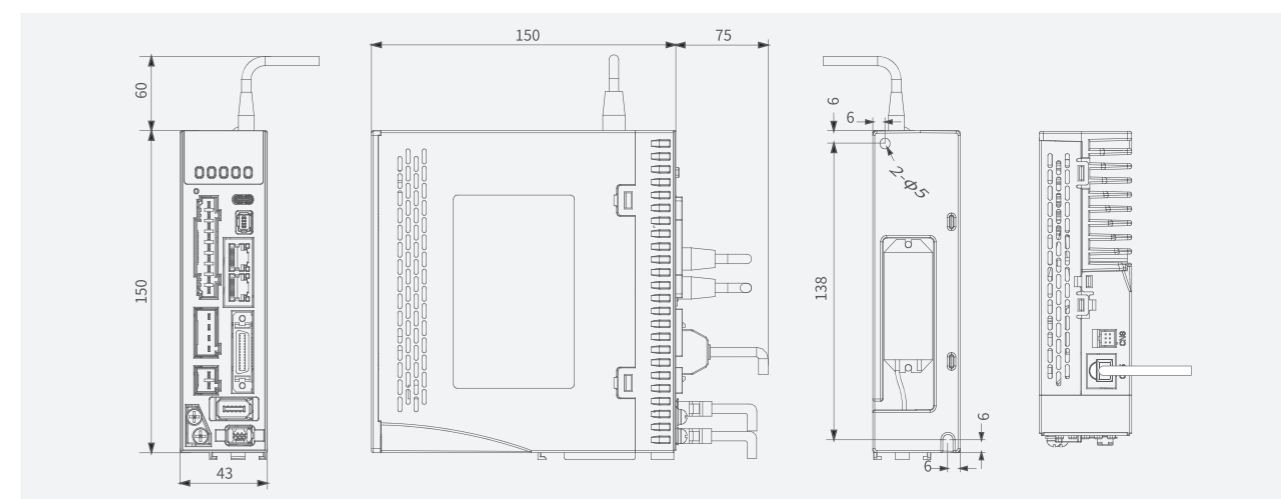

750W/1000W (AC 220V)

Unit: mm

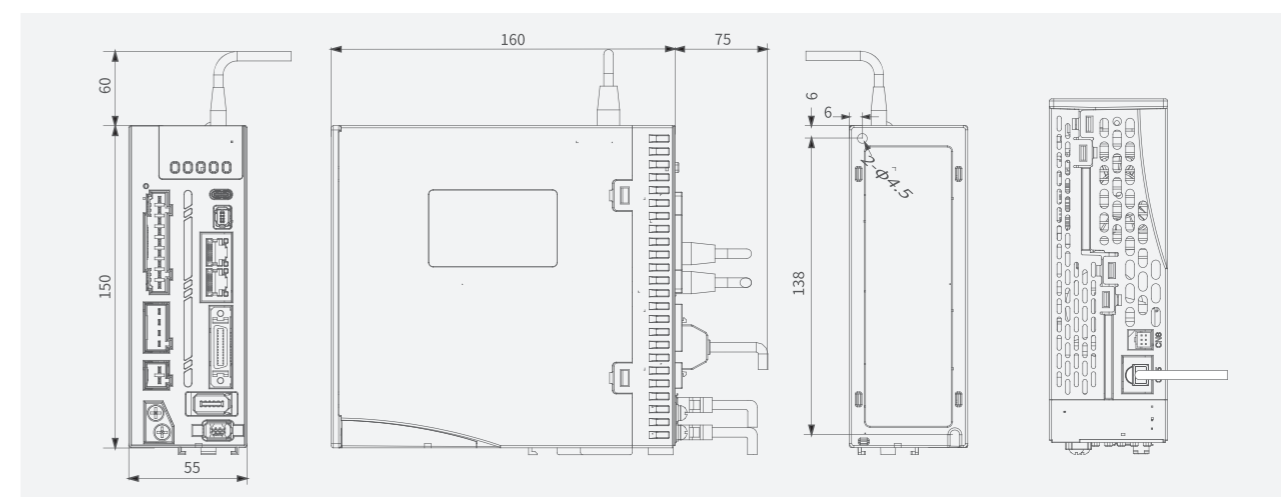

1500W/2000W (AC 220V)

Unit: mm

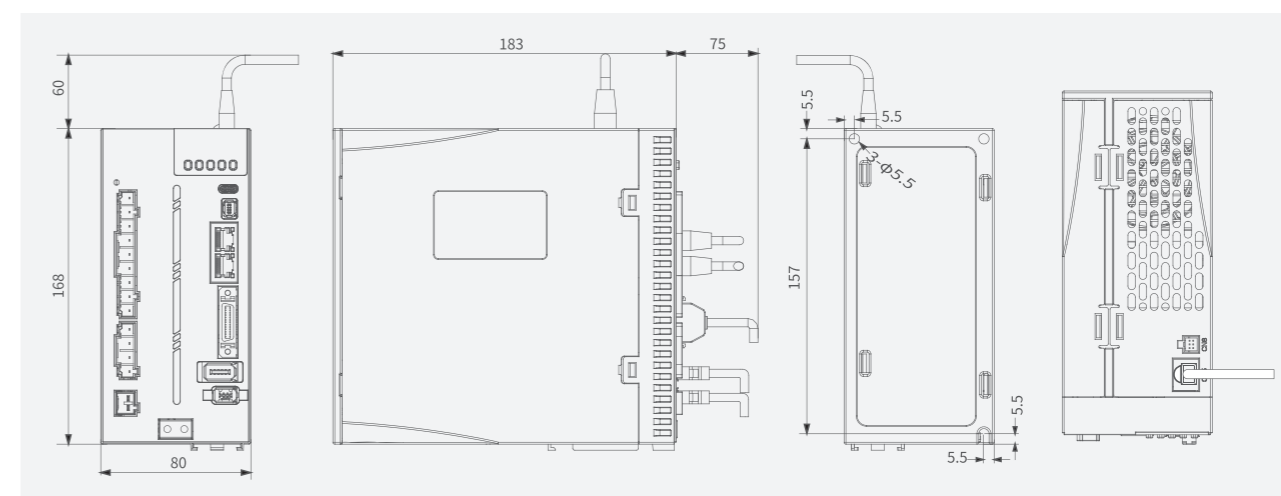

EL8-EC & Peripheral Wiring Diagram

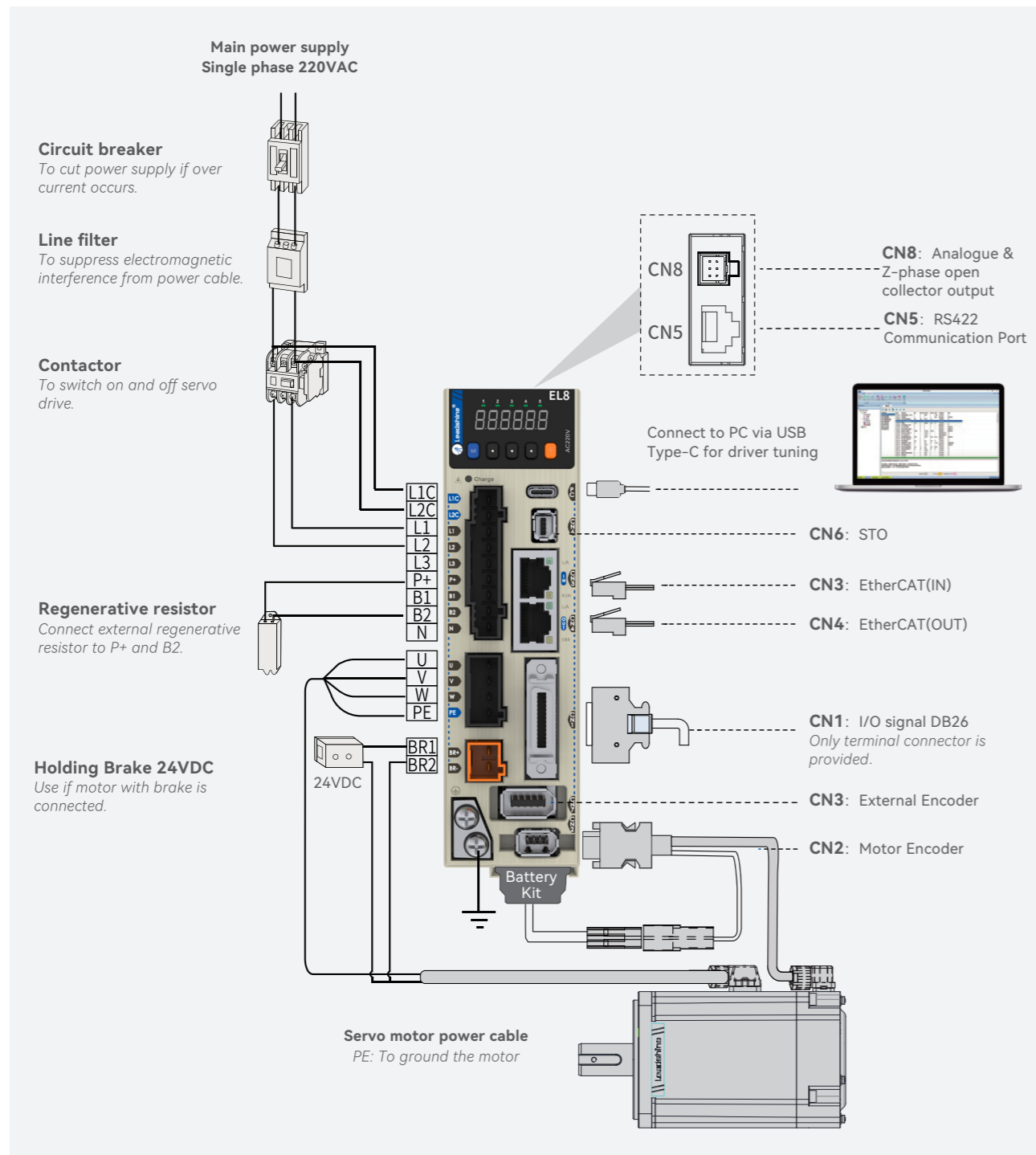

EL8-RS & Peripheral Wiring Diagram

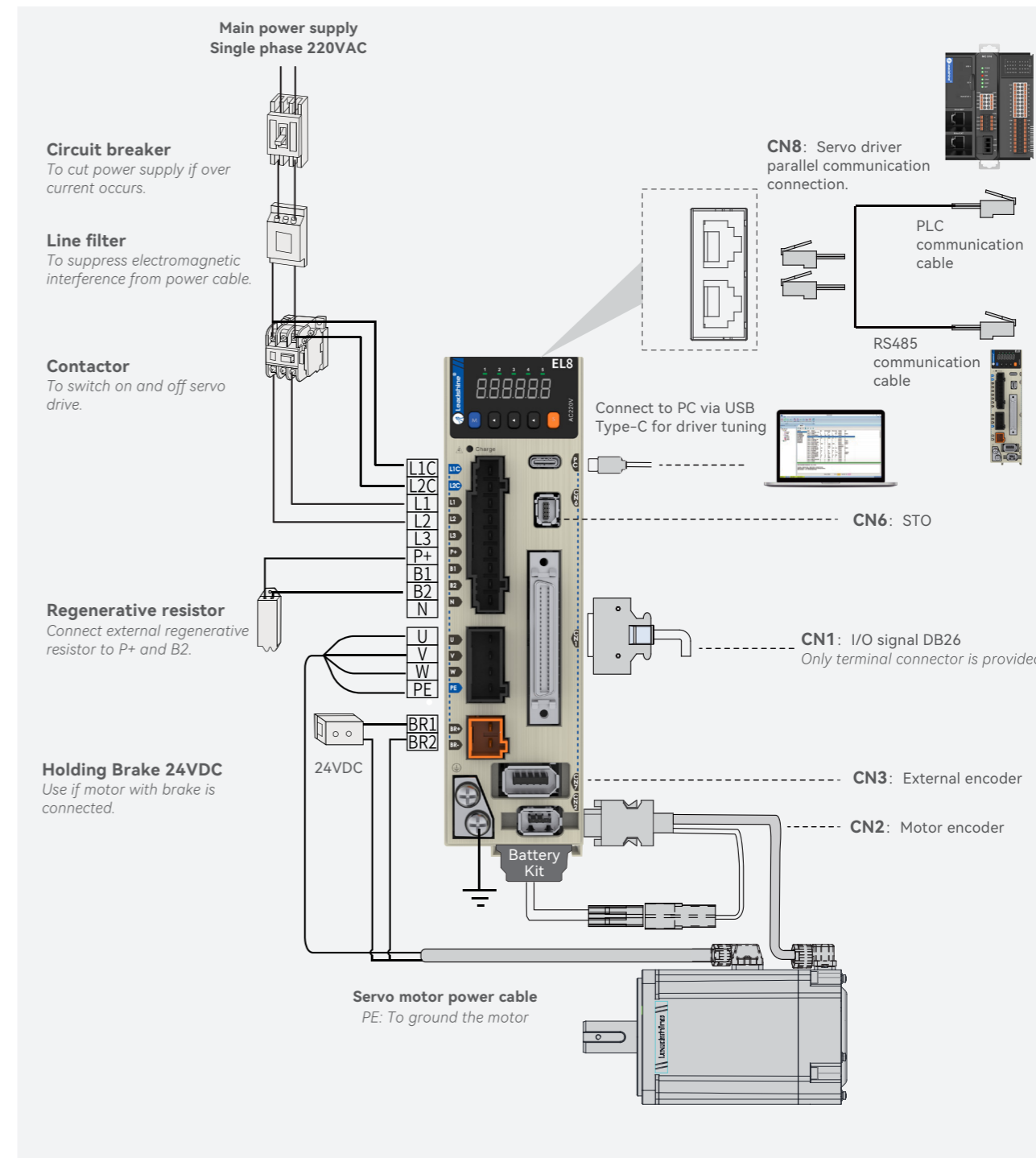

Specifications

EL8 Series Drive	EL8-RS400F EL8-EC400F	EL8-RS750F EL8-EC750F	EL8-RS1000F EL8-EC1000F	EL8-RS1500F EL8-EC1500F	EL8-RS2000F EL8-EC2000F
Power Rating	400W	750W	1000W	1500W	2000W
Rated Current (A)	2.8	5.5	7.0	9.5	12
Peak Current (A)	9.3	16.9	21.2	31.1	36
Control circuit power supply	1-Ph AC 200V- 240VAC, -10% - +10%, 50/60Hz				
Main power supply	1-Ph/3-Ph AC 200V- 240VAC, -10% - +10%, 50/60Hz				
Dimension L*H*W(mm)	150*150*43	150*160*55		168*183*80	

Ports	Descriptions
EL8-RS	
Low-speed pulse input	5V differential signal, 0-500kHz 24V differential signal, 0-200kHz
High-speed pulse input	5V differential signal, 0-4MHz
Analog I/O	3 analog inputs (AI1/AI2/AI3) , -10V~+10V, Max. voltage: ±12V 3 analog outputs (AO1/AO2) , -10V~+10V
Digital I/O	10 Digital Inputs (Supports common anode or cathode connection) 6 digital outputs (2 single ended, 4 double-ended)
EL8-EC	
Analog I/O	2 analog inputs (AI1/AI2) , -10V~+10V, Max. voltage: ±12V 2 analog outputs (AO1/AO2) , -10V~+10V
Digital I/O	8 Digital Inputs (Supports common anode or cathode connection) 3 Digital outputs (3 double-ended, DO1~DO3)
Safe Torque Off (STO)	Available for all EL8 series servo drives
External encoder	Internal holding brake. External relay not needed
Holding brake	Supports phase A/B/Z differential crossover frequency output Supports phase Z open collector crossover frequency output
Crossover Frequency Output	EtherCATModbus protocol, RJ45 port
Communication Port	Modify or read driver parameters without connecting to main power supply
USB Type-C	
Control Mode (EL8-RS)	
Control	1. External pulse train position control 2. JOG control 3. Closed loop position control 4. Velocity control 5. Torque control 6. Hybrid control: Position-Torque/Position-Velocity/Velocity-Torque

Control Mode (EL8-EC)	
Position	Profile Position Mode (PP)
	Cyclic Synchronous Position Mode (CSP)
	Homing Mode (HM)
Velocity	Profile Velocity Mode (PV)
	Cyclic Synchronous Velocity Mode (CSV)
Torque	Profile Torque Mode (PT)
	Cyclic Synchronous Torque Mode (CST)
Control Mode(EL8-EC)	
Feedback Method	Encoder: RS485 Protocol
Easy-to-use	One-click tuning, Single parameter tuning, Black box, Zero tracking control
Notch Filter	Mechanical resonance suppression. Supports up to 3 filters,50Hz~4000Hz
Vibration suppression	End vibration suppression
Alarm	Overcurrent. Overvoltage. Undervoltage. Overheat. Overload. Overtravel. Single-Phasing. Regenerative resistor error. Position deviation error. Encoder feedback error. Excessive braking rate. EEPROM error
Front Panel	5 push buttons, 8-segments display, 5 warning LEDs
Software	Driver tuning through Motion Studio Ver. 2.x.
Dynamic Brake	Internal dynamic brake
Position Comparison	42 position comparison outputs
Environmental requirements	
Temperature	Storage: -20-80°C (Condensation free); Not more than 72 hours if stored in over 65°C Installation: 0-55°C (Not frozen); Lower performance at over 45°C
Humidity	Under 90%RH (Condensation free)
Altitude	Max. altitude of 2000m; 100% performance at 1000m or below. Performance decreases by 1% with every increase of 100m from 1000m.
Vibration	Less than 0.5G (4.9m/s ²) 10-60Hz (non-continuous working)
IP ratings	IP20

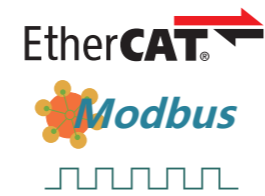

High End AC Servo Drives

EL8-L Series

EL8-L Series AC Servo Drives are our latest high end servo drives which now supports linear motors. This series of servo drive comes with EtherCAT control and another version which combines analogue control, Modbus RTU protocol (RS485) and pulse + direction control into one. We added STO SIL3, analogue I/Os, holding brake port and EL8 series now supports a 2nd external encoder for optical/magnetic scale feedback of a linear motor.



Machine tools



Electronics



Renewable energy



Fiber laser



Semiconductor

Overview

Quick Frequency Response

Frequency response of 3.5kHz, quicker system response and better precision.

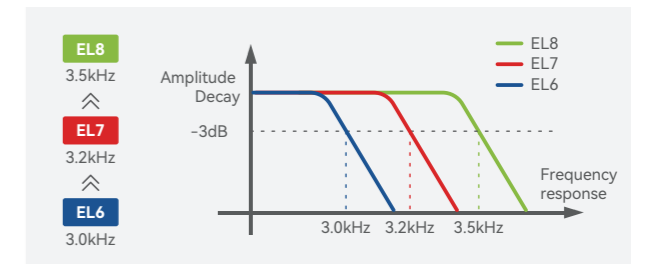

Gantry synchronization

Gantry synchronization MIMO technique, breaking through foreign technological barrier.

EL8 series servo drive is able to realize axis synchronization and alignment automatically without input from master device.

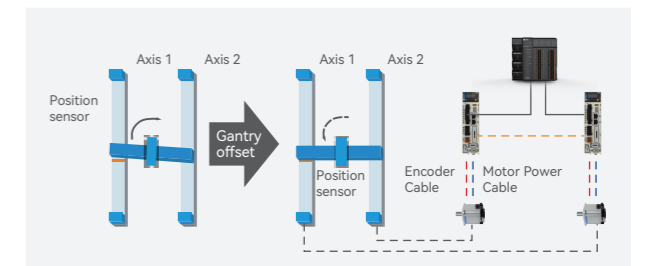

Safe Torque Off (SIL3)

When Safe Torque Off is activated, internal circuit will cut off motor power supply immediately, guaranteeing operator and machine safety.

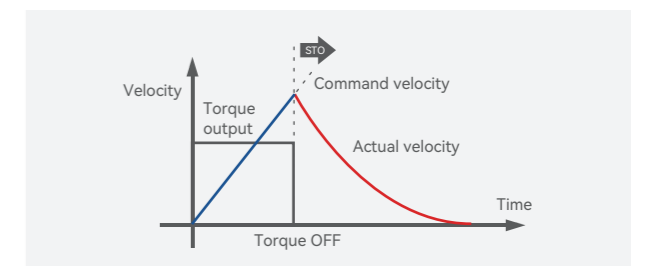

Position Comparison

Up to 42 points of position comparison.

Drive with analogue input up to 16 bit data for more precise sampling.

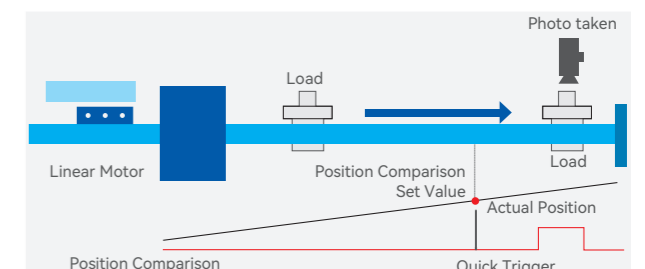

Matching Motor Types

- Linear
- Direct Drive
- Voice Coil



Part Numbers

EL8 - EC 030 L

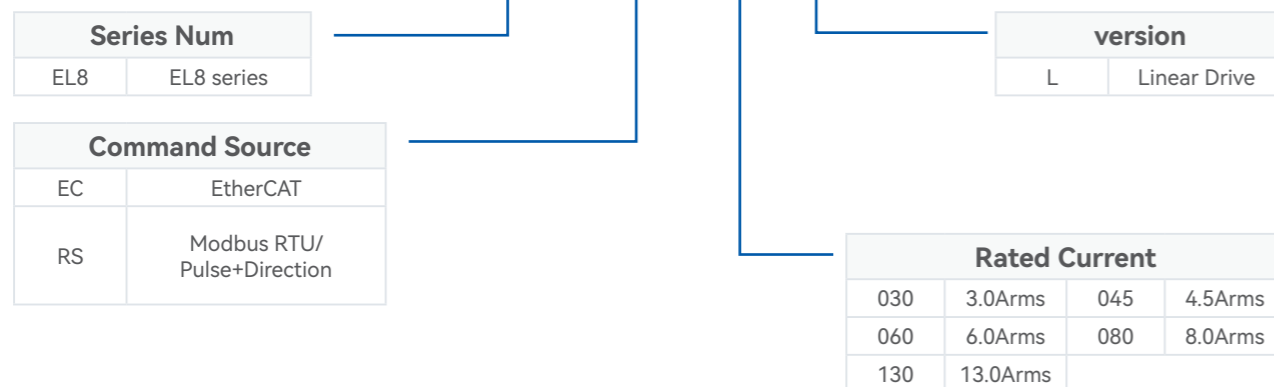

EL8-L & Peripheral Wiring Diagram

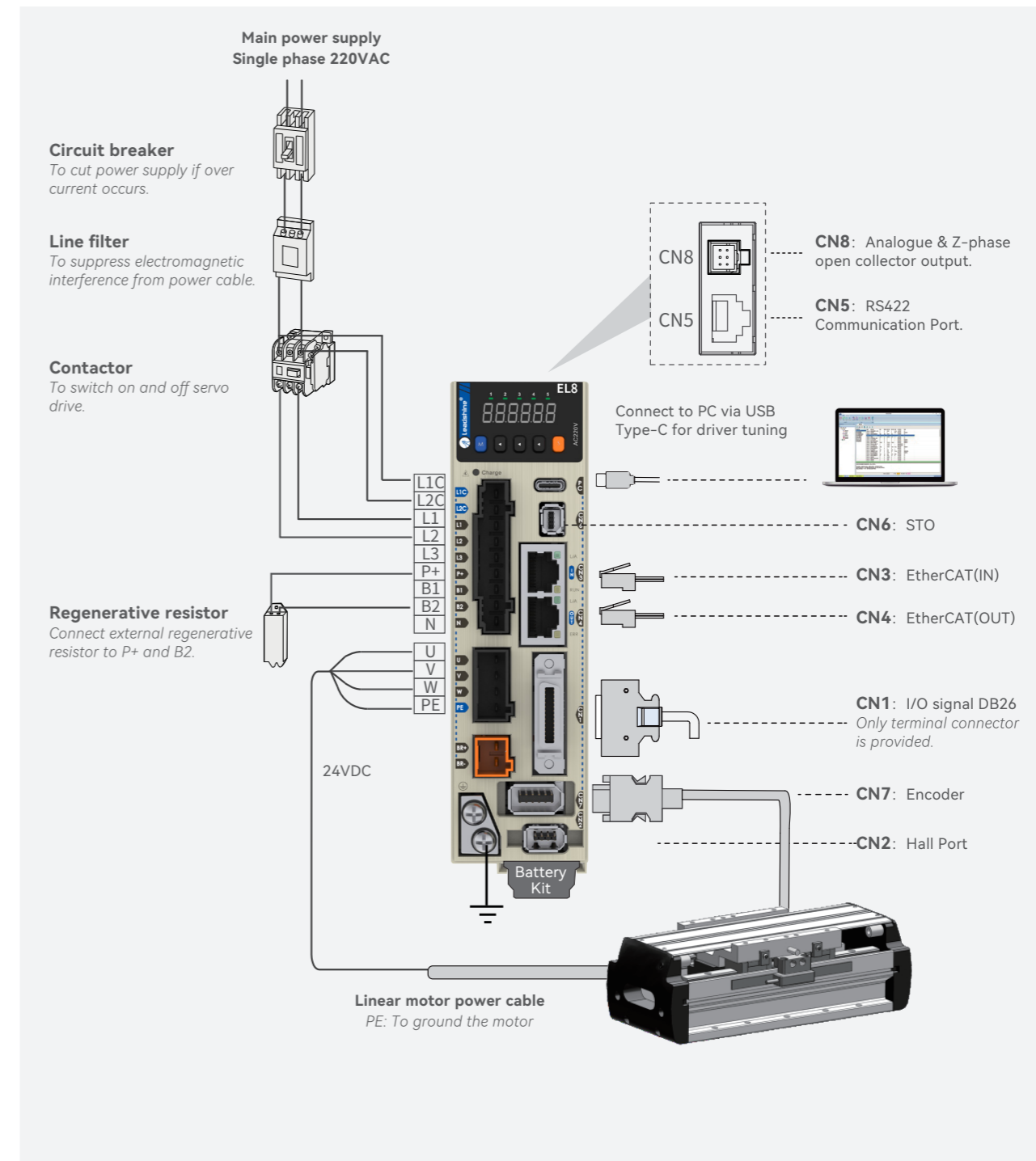

Ports & Connectors

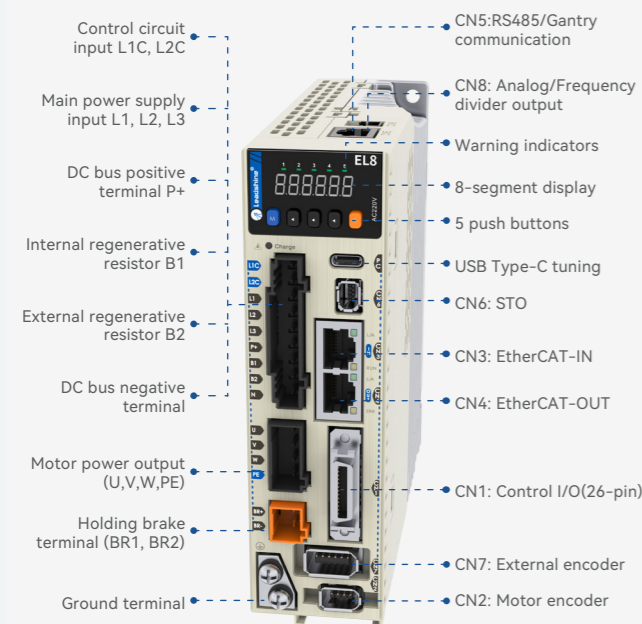

EL8 - ECL Series

Specifications

1-Phase/3-Phase 200-240VAC, 50/60Hz

Drive Models	Rated Current (Arms)	Peak Current (Arms)	Dimension (L*H*W mm)
EL8-RS030L	3.0	9.3	150*150*43
EL8-EC030L			
EL8-RS045L	4.5	18.5	160*150*55
EL8-EC045L			
EL8-RS060L	6.0	21.0	183*168*80
EL8-EC060L			
EL8-RS080L	8.0	28.0	183*168*80
EL8-EC080L			
EL8-RS130L	13.0	36.0	183*168*80
EL8-EC130L			



Overview

Frequency response

Quicker system response of 3.2kHz for higher precision control.

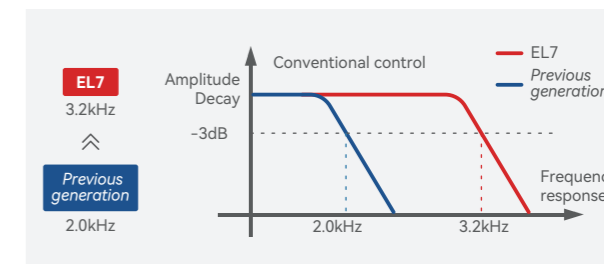

Advanced servo computing

One-Click Tuning – Follow a few easy steps to get servo tuning done. Gain adjustments will be automatically set, shortening tuning time.

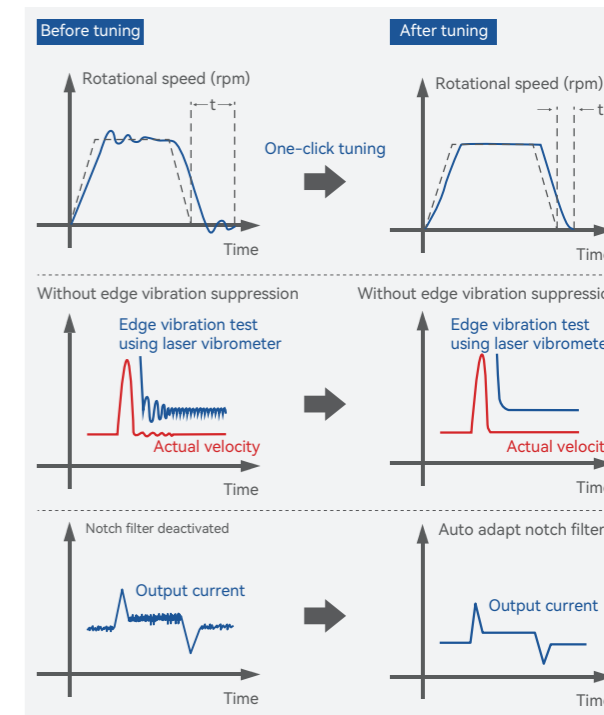

End vibration suppression for flexible structure – suppress low frequency vibration under 200Hz for a quicker and more precise position settling.

Adaptive notch filters – 3 sets of notch filters up to 4kHz for better suppression of structural vibration.

Zero tracking control

Able to realize a zero position deviation during acceleration/ deceleration by improving multi-axis precision and following.

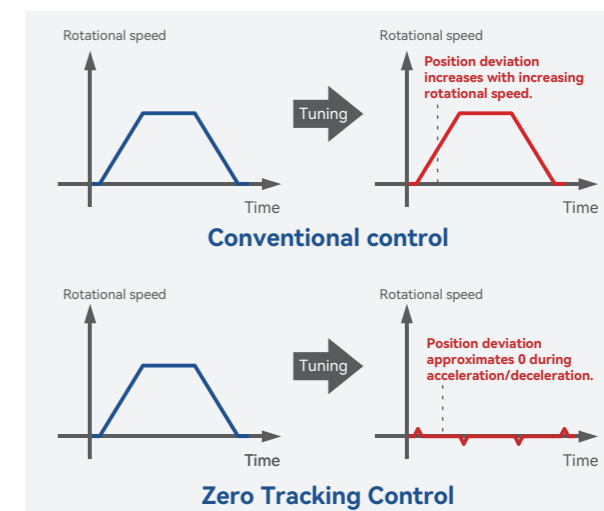

General Purpose AC Servo Drives

EL7-RS Series

EL7-RS Series AC Servo Product is a whole new midrange AC servo drivers and motors product range that we have proudly developed at Leadshine Technology Co.,Ltd. This product series provides more in demanded functionalities and control. While designing this AC servo drive series with cost concerns in mind, this product series doesn't compromise in term of performance and functions.

EL7-RS Series AC Servo Drive comes with power rating from 400W up to 7500W which supports Modbus communication protocol in addition to analogue and pulse + direction input control. Using RS485 protocol, multi axis network of EL7-RS series servo drive can be realized and controlled from 1 single master device.



Part Numbers

EL7 - RS 750 P T

Series Num		Voltage	
EL7	EL7 series	Blank	220VAC
		T	400VAC

Command Source		Version	
EC	EtherCAT	P	Full functions without STO
RS	Modbus RTU/ Analog Input/ Pulse+Direction		

Rated Power			
400	400W	750	750W
1000	1000W	1500	1500W
2000	2000W	3000	3000W
4400	4400W	5500	5500W
7500	7500W		

Ports & Connectors

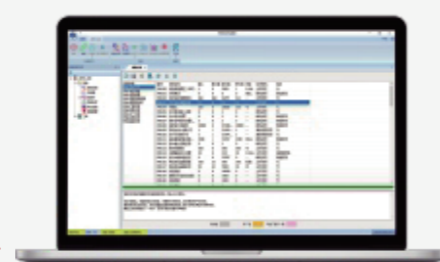
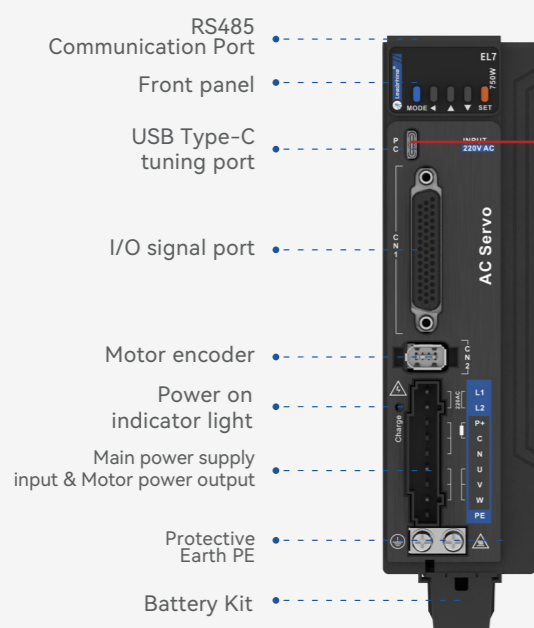

Tuning via USB Type-C

- Tuning can be done via USB Type-C tuning port.
- Main power supply is not needed for parameter reading and writing.

400W (AC 220V)

Unit: mm

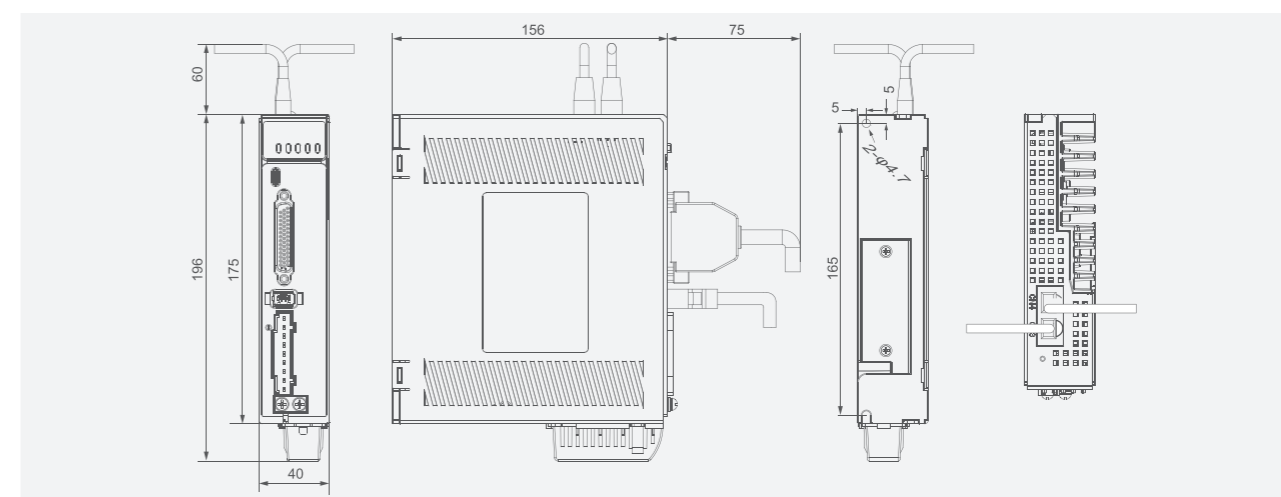

750W/1000W (AC 220V)

Unit: mm

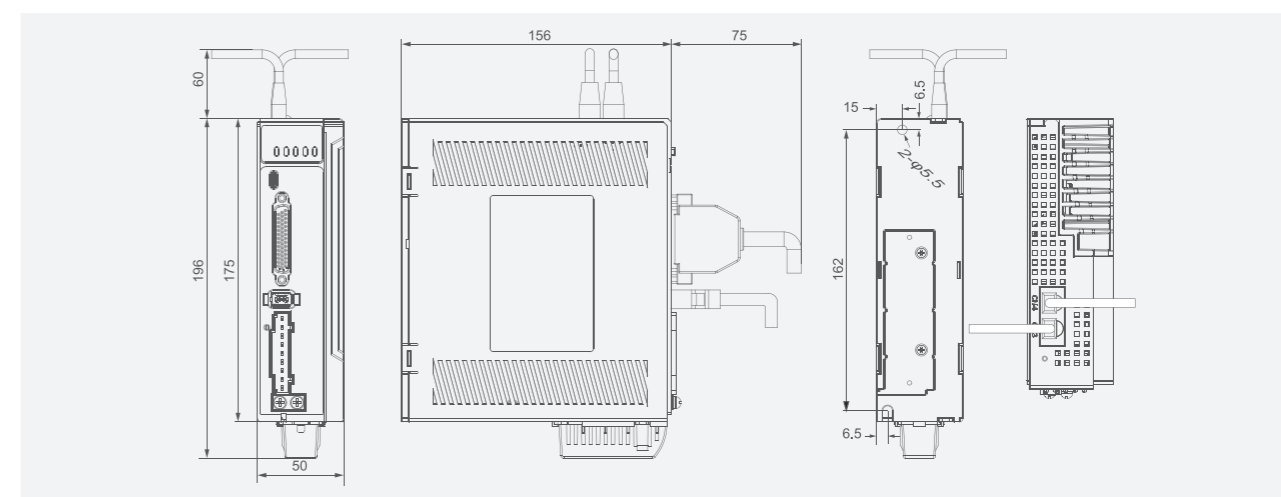

1500W/2000W (AC 220V)

Unit: mm

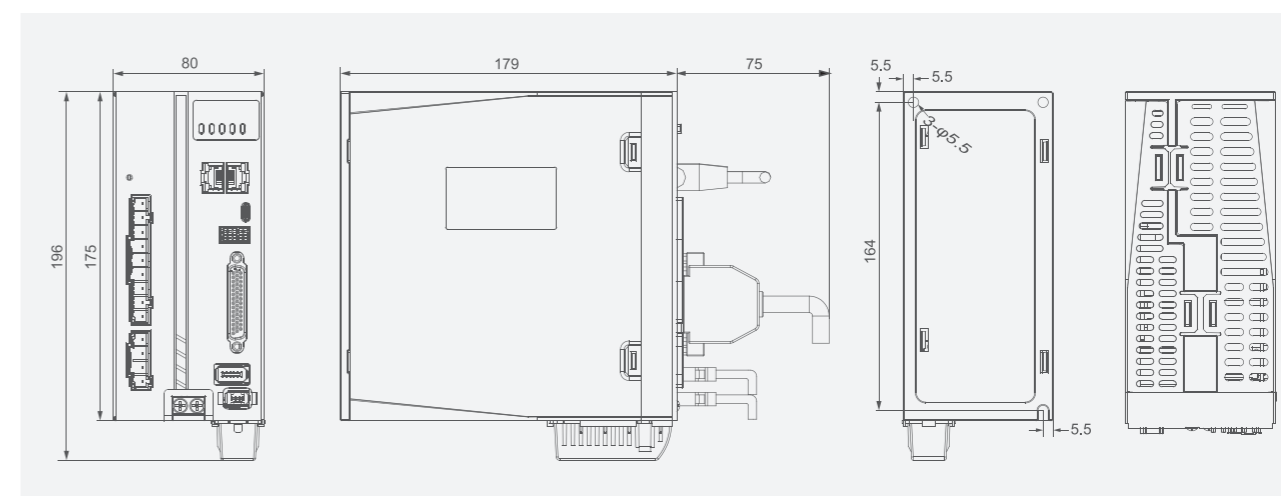

750W/1000W/1.5kW (AC 400V)

Unit: mm

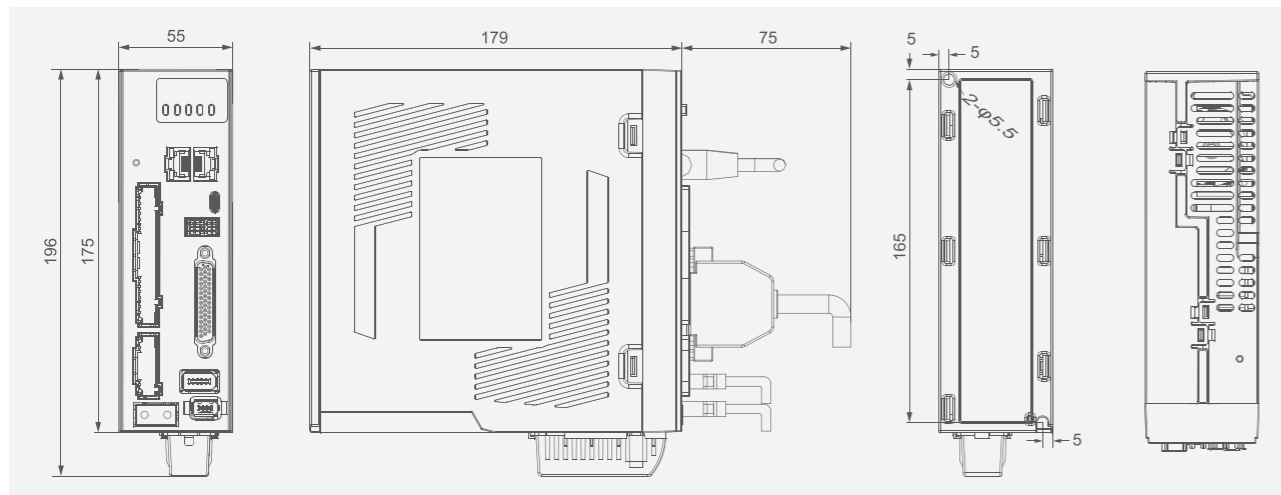

2kW/3kW (AC 400V)

Unit: mm

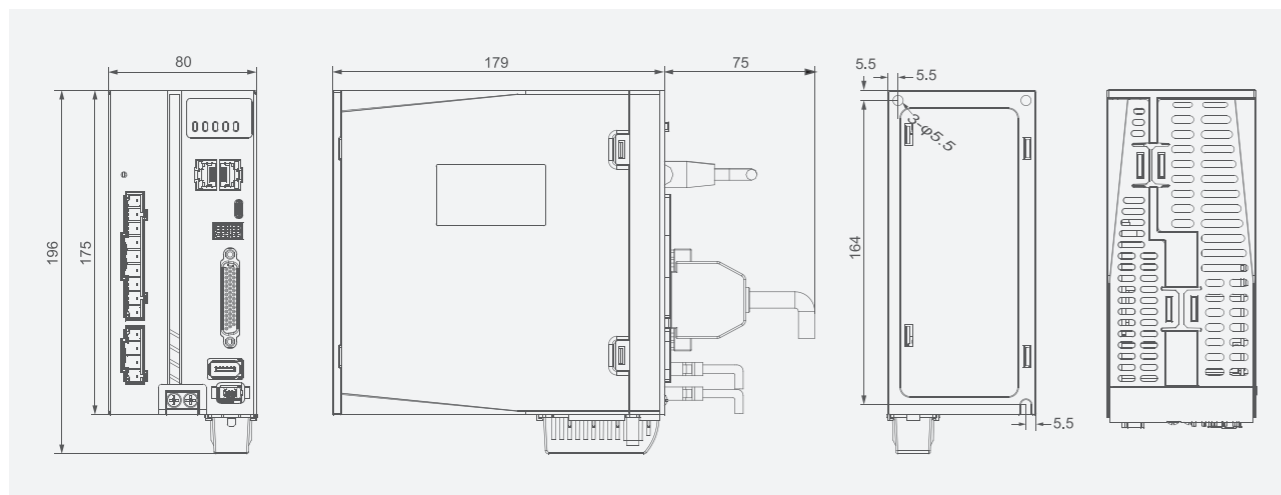

4.4kW/5.5kW/7.5kW (AC 400V)

Unit: mm

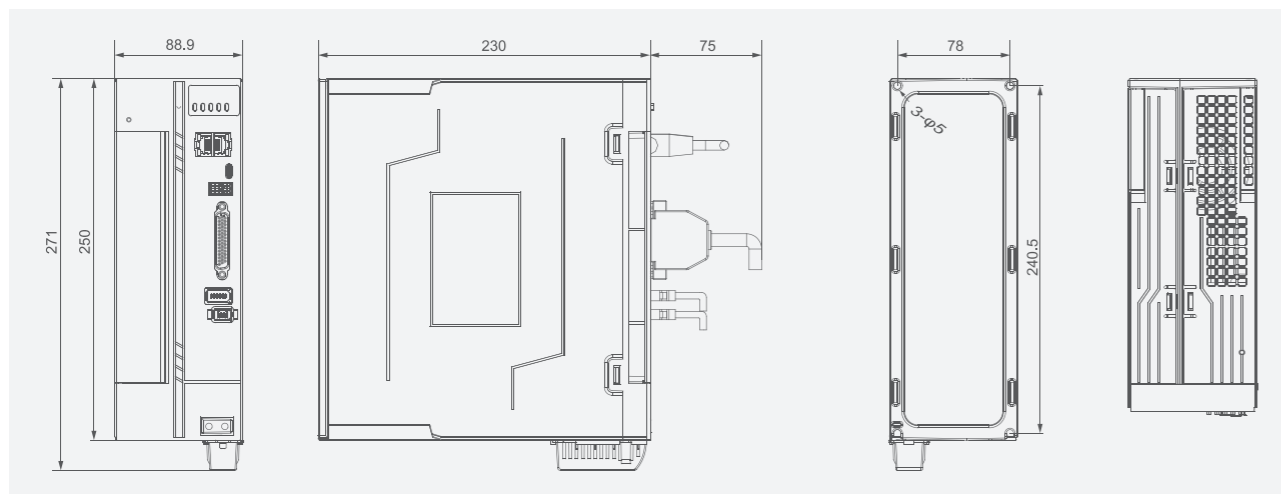

EL7-RS & Peripheral Wiring Diagram

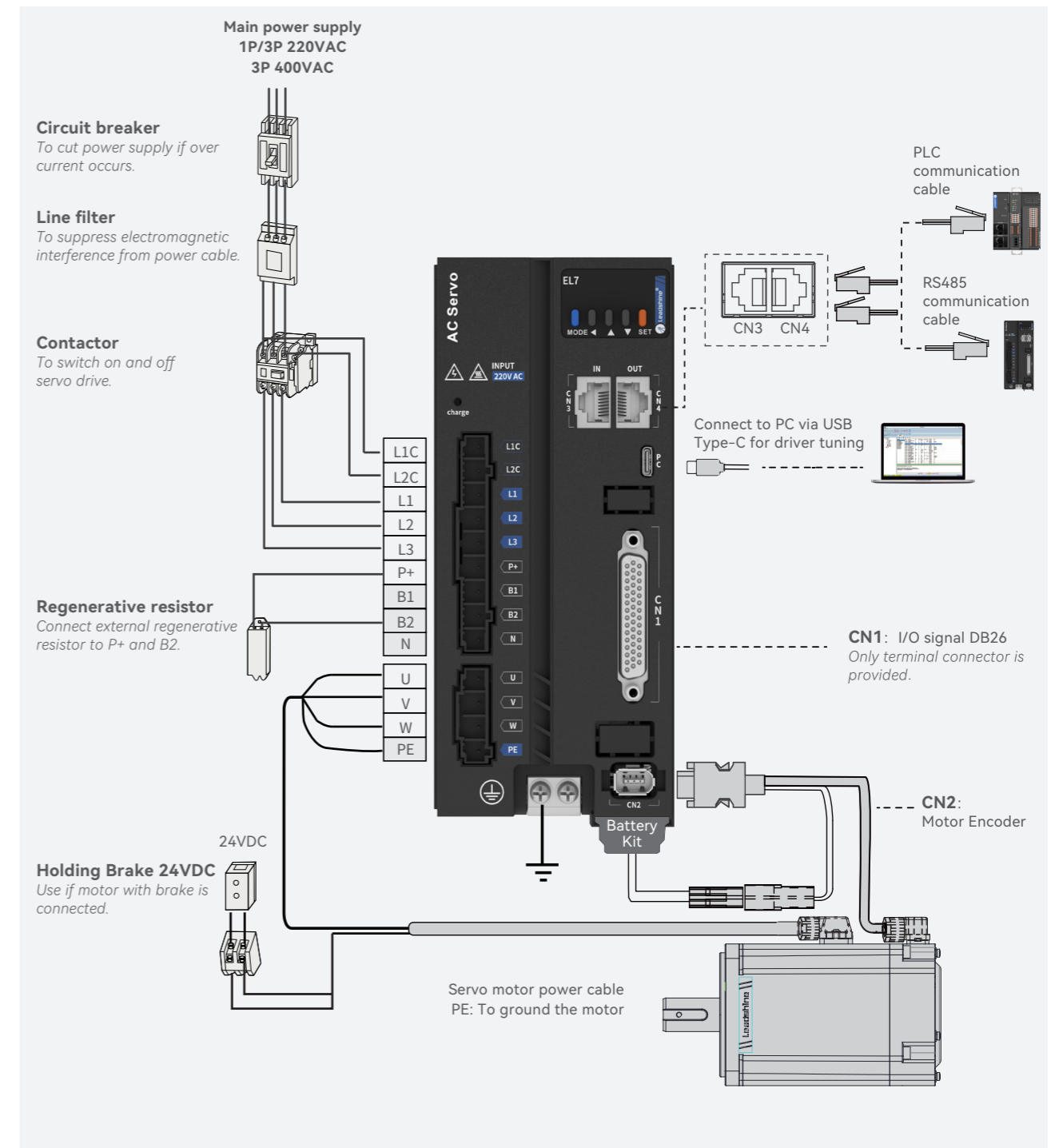

Specifications

EL7-RS 220V Models

EL7-RSP Series Driver	EL7-RS400P	EL7-RS750P	EL7-RS1000P	EL7-RS1500P	EL7-RS2000P
Power Rating	400W	750W	1000W	1500W	2000W
Rated Current (Arms)	3.5	5.5	7.0	9.5	12
Peak Current (Arms)	9.5	16.6	18.7	31.1	36
Control circuit power supply	1-Ph AC 200V~240V, -10% - +10%, 50/60Hz				
Main power supply					
Dimension H*L*W(mm)	175*156*40	175*156*50	175*156*80		

EL7-RS 400V Models

EL7-RSPT series	EL7-RS750PT	EL7-RS1000PT	EL7-RS1500PT	EL7-RS2000PT	EL7-RS3000PT	EL7-RS4400PT	EL7-RS5500PT	EL7-RS7500PT
Rated Power(W)	750	1000	1500	2000	3000	4400	5500	7500
Rated Current (Arms)	2.7	3.5	5.4	8.4	11.9	16.5	20.8	25.7
Peak Current (Arms)	8.6	10.6	14.9	24.8	33.2	38.9	51.6	33.6
Control circuit power supply	Three phase AC 380V~440V, -15%~+10%, 50/60Hz							
Main power supply	Single phase AC 380V~440V, -15%~+10%, 50/60Hz							
Dimension L*H*W(mm)	175*179*55		175*179*80		250*230*89			

Ports	Descriptions
USB Type-C Tuning	Modify or read driver parameters without connecting to main power supply
Low-speed pulse input	5V differential signal, 0-500kHz 24V single ended signal, 0-200kHz
High-speed pulse input	5V differential signal, 0-4MHz
High-speed pulse input	5V differential signal, 0-4MHz 3 analog inputs (AI1/AI2/AI3) , -10V~+10V, Max. voltage: ±12V
Crossover Frequency Output	Supports phase A/B/Z differential crossover frequency output Supports phase Z open collector crossover frequency output
Analog I/O	2 analog inputs (AI1/AI2) , -10V~+10V, Max. voltage: ±12V 1 analog output (AO1) , -10V~+10V
Digital I/O	8 Digital Inputs (Supports common anode or cathode connection) DI1~DI8 5 digital outputs (double-ended) DO1~DO5
Communication Port	RS485 communication, Modbus RTU protocol (RJ45 port)

Control Mode	
Control	1. External pulse train position control 2. JOG control 3. Velocity control 4. Torque control 5. Hybrid control: Position-Torque/Position-Velocity/Velocity-Torque
Control Features	
Drive Mode	IGBT SVPWM sinusoidal wave drive
Encoder feedback	Encoder: RS485 Protocol
Easy-to-use	One-click tuning, Single parameter tuning, Black box, Zero tracking control
Notch Filter	Mechanical resonance suppression. Supports up to 3 filters, 50Hz~4000Hz
Vibration suppression	End vibration suppression
Alarm	Overcurrent. Overvoltage. Undervoltage. Overheat. Overload. Overtravel. Single-Phasing. Regenerative resistor error. Position deviation error. Encoder feedback error. Excessive braking rate. EEPROM error
Front Panel	5 push buttons, 8-segments display
Software	Driver tuning through Motion Studio Ver. 2.x.
Dynamic Brake	Internal dynamic brake
Black Box	Set triggering conditions and analyze the data from black box. Used for error solving
Environmental requirements	
Temperature	Storage: -20-80°C (Condensation free); Not < 72 hours if stored in over 65°C Installation: 0-55°C (Not frozen); Lower performance at over 45°C
Humidity	Under 90%RH (Condensation free)
Altitude	Max. altitude of 2000m; 100% performance at 1000m or below. Performance decreases by 1% with every increase of 100m from 1000m.
Vibration	Less than 0.5G (4.9m/s ²) 10-60Hz (non-continuous working)
IP ratings	IP20



Overview

Frequency response

Quicker system response of 3.2kHz for higher precision control.

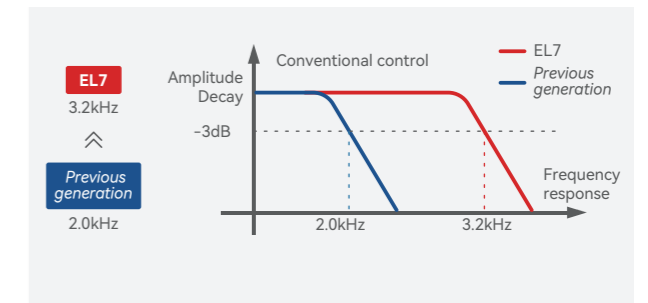

Safe Torque Off (STO) SIL3

Ensures that no torque-generating energy can act upon a motor at emergency stop and prevents unintentional starting.

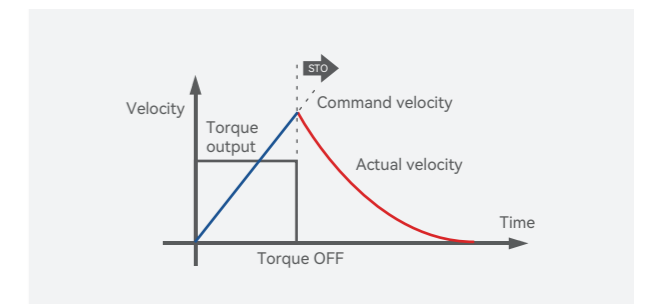

Black Box

Able to record operation data at the moment when error occurs for quick analysis of drive fault. Maximum of 22 channels.

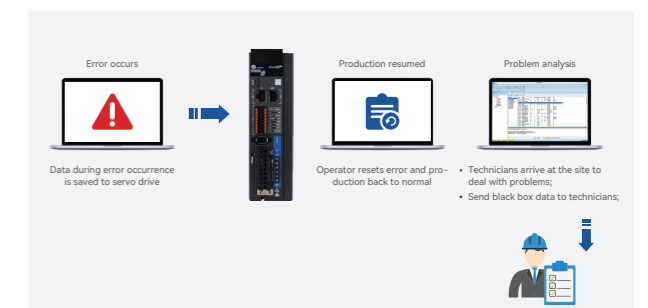

Real Time Position Control

Through touch probe input, real time motor position feedback can be recorded.

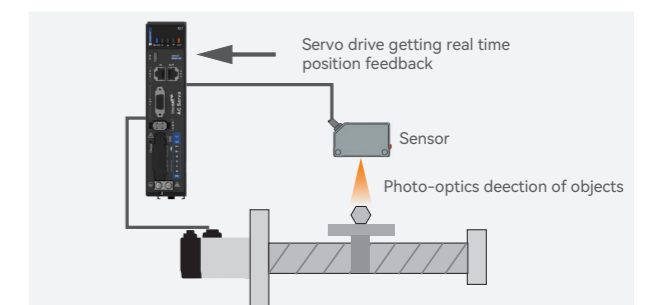

General Purpose EtherCAT AC Servo Drives

EL7-ECN Series

EL7-EC Series AC servo products are high performance AC digital servo which is designed for position/velocity/torque high accurate control with power rating ranging up to 2kW for 220VAC models and 7.5kW for 380VAC models which provides a perfect solution for different applications with easy tuning process.

- Robotic Arm
- Semiconductor
- Fiber Laser
- Electronics
- Machine Tools
- Logistics
- Packaging

Part Numbers

EL7 - EC 750 N T

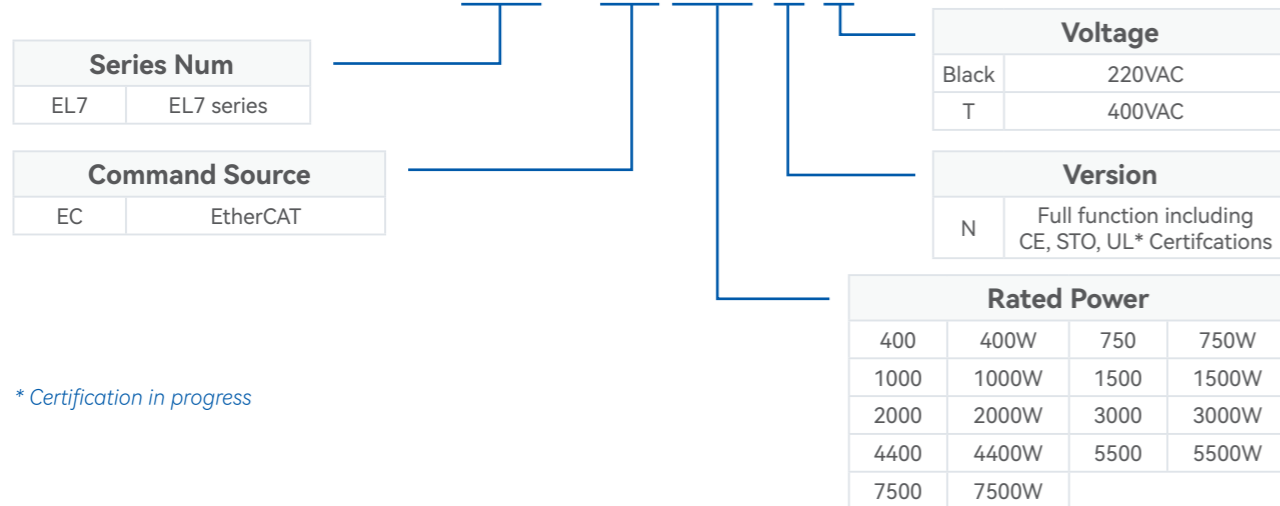

* Certification in progress

Ports & Connectors

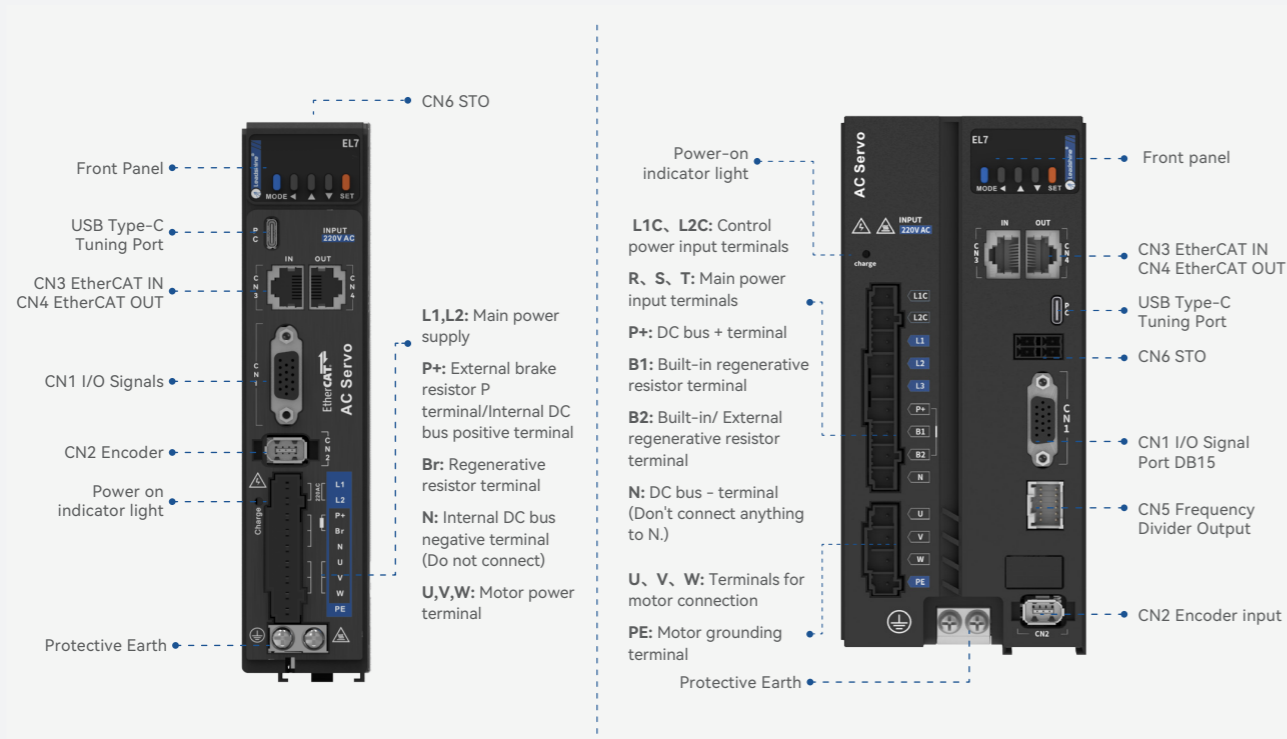

EL7-ECN & Peripheral Wiring Diagram

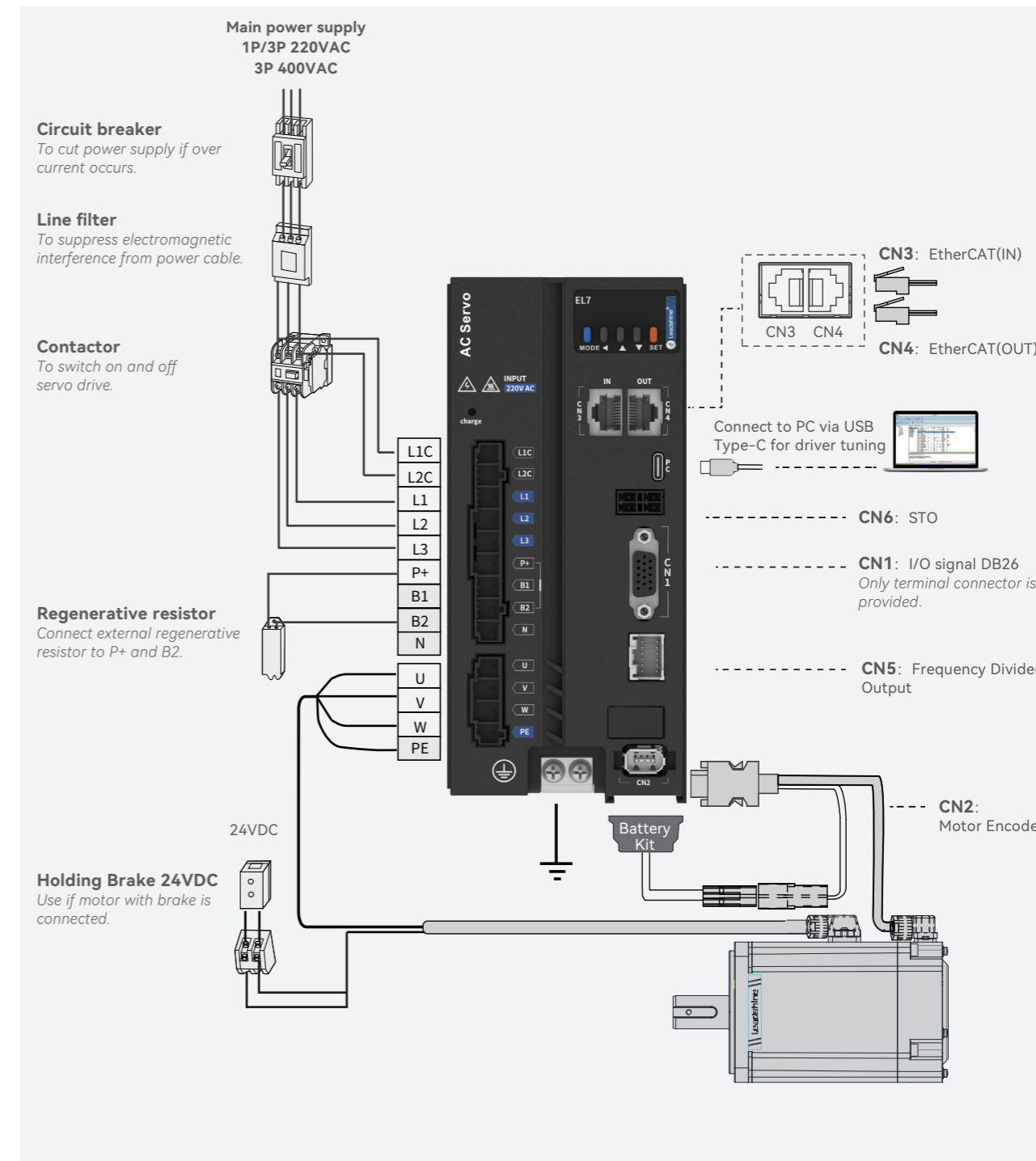

Specifications

EL7-EC 220V Models

EL7-ECN series	EL7-EC400N	EL7-EC750N	EL7-EC1000N	EL7-EC1500N	EL7-EC2000N
Rated power (W)	400	750	100	1500	2000
Rated Current (Arms)	3.5	5.5	7	9.5	12
Peak Current (Arms)	9.2	16.6	18.7	31.1	36
Main Power Supply	Single phase AC 220V, -15%~+10%, 50/60Hz				
Control Circuit Power Supply					
Dimension H*L*W(mm)	175*156*40	175*156*50	175*179*80		

EL7-EC 400V Models

EL7-ECNT series	EL7-EC750NT	EL7-EC1000NT	EL7-EC1500NT	EL7-EC2000NT	EL7-EC3000NT	EL7-EC4400NT	EL7-EC5500NT	EL7-EC7500NT
Rated Power(W)	750	1000	1500	2000	3000	4400	5500	7500
Rated Current (Arms)	2.7	3.5	5.4	8.4	11.9	16.5	20.8	25.7
Peak Current (Arms)	8.6	10.6	14.9	24.8	33.2	38.9	51.6	33.6
Main Power Supply	Three phase AC 380V~440V, -15%~+10%, 50/60Hz							
Control Circuit Power Supply	Single phase AC 380V~440V, -15%~+10%, 50/60Hz							
Dimension L*H*W(mm)	175*179*55		175*179*80			250*230*89		

Ports	Descriptions
USB Type-C Tuning	Modify or read driver parameters without connecting to main power supply
Crossover Frequency Output	Supports phase A/B/Z differential crossover frequency output Supports phase Z open collector crossover frequency output
Digital I/O	8 Digital Inputs (Supports common anode or cathode connection) DI1~DI8 5 digital outputs (double-ended) DO1~DO5
Communication Port	RS485 communication, Modbus RTU protocol (RJ45 port)
Control Mode	
Position	Profile Position Mode (PP)
	Cyclic Synchronous Position Mode (CSP)
	Homing Mode (HM)
Velocity	Profile Velocity Mode (PV)
	Cyclic Synchronous Velocity Mode (CSV)
Torque	Profile Torque Mode (PT)
	Cyclic Synchronous Torque Mode (CST)

Control Features	
Drive Mode	IGBT SVPWM sinusoidal wave drive
Encoder feedback	Encoder: RS485 Protocol
Easy-to-use	One-click tuning, Single parameter tuning, Black box, Zero tracking control
Notch Filter	Mechanical resonance suppression. Supports up to 3 filters,50Hz~4000Hz
Vibration suppression	End vibration suppression
Alarm	Overcurrent. Overvoltage. Undervoltage. Overheat. Overload. Overtravel. Single-Phasing. Regenerative resistor error. Position deviation error. Encoder feedback error. Excessive braking rate. EEPROM error
Front Panel	5 push buttons, 8-segments display
Software	Driver tuning through Motion Studio Ver. 2.x.
Dynamic Brake	Internal dynamic brake
Black Box	Set triggering conditions and analyze the data from black box. Used for error solving
Environmental requirements	
Temperature	Storage: -20~80°C (Condensation free); Not < 72 hours if stored in over 65°C Installation: 0~55°C (Not frozen); Lower performance at over 45°C
Humidity	Under 90%RH (Condensation free)
Altitude	Max. altitude of 2000m; 100% performance at 1000m or below. Performance decreases by 1% with every increase of 100m from 1000m.
Vibration	Less than 0.5G (4.9m/s ²) 10~60Hz (non-continuous working)
IP ratings	IP20

400W (AC 220V)

Unit: mm

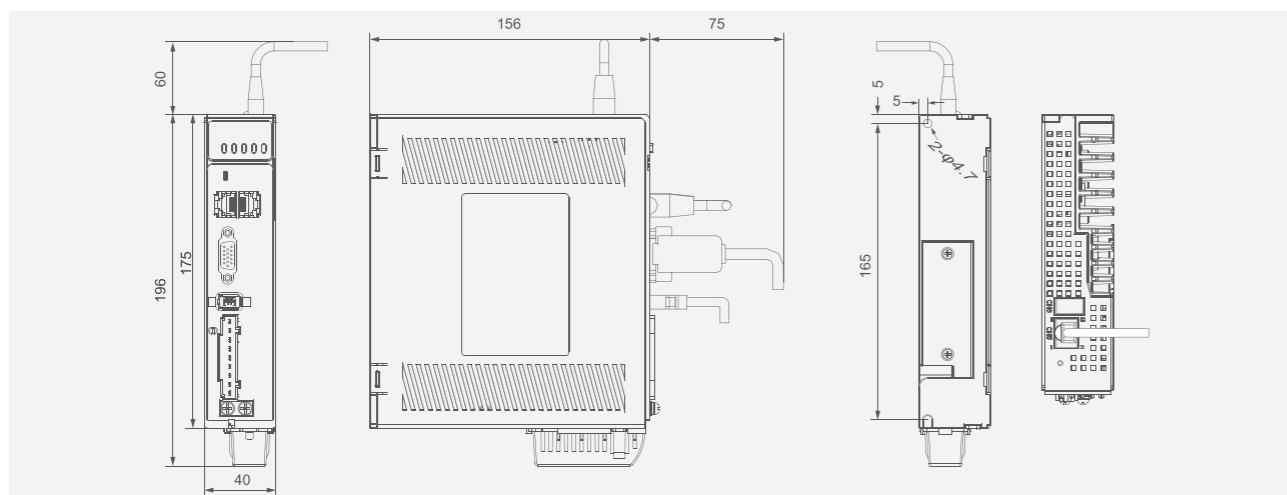

750W/1000W/1.5kW (AC 400V)

Unit: mm

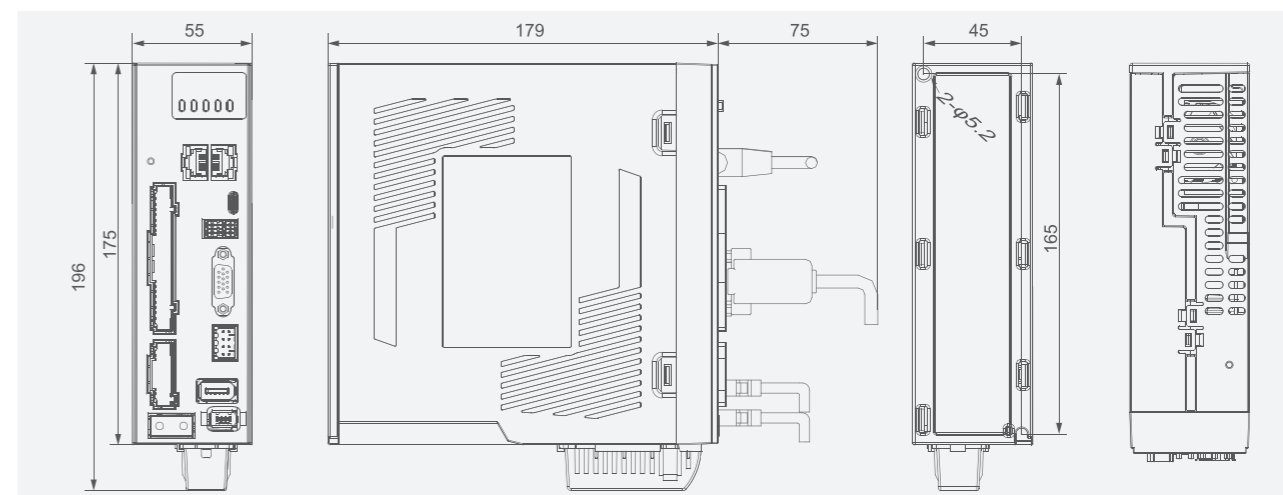

750W/1000W (AC 220V)

Unit: mm

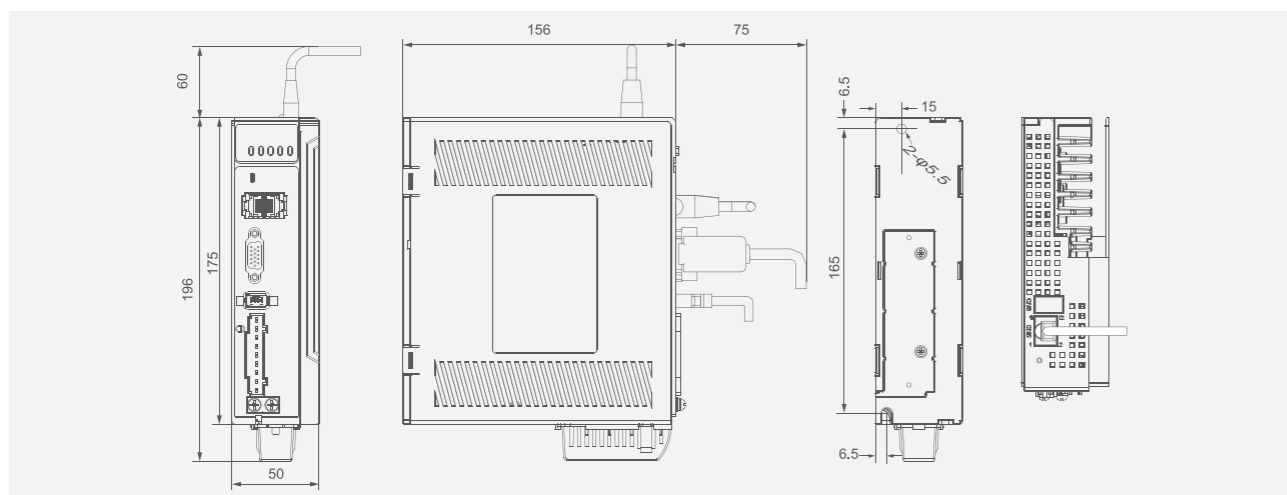

2kW/3kW (AC 400V)

Unit: mm

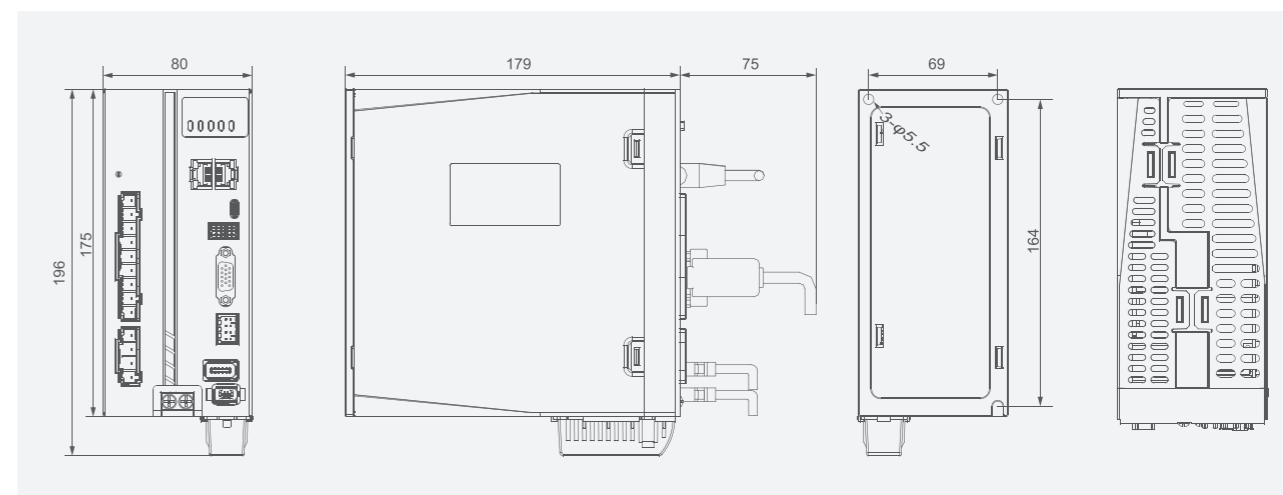

1500W/2000W (AC 220V)

Unit: mm

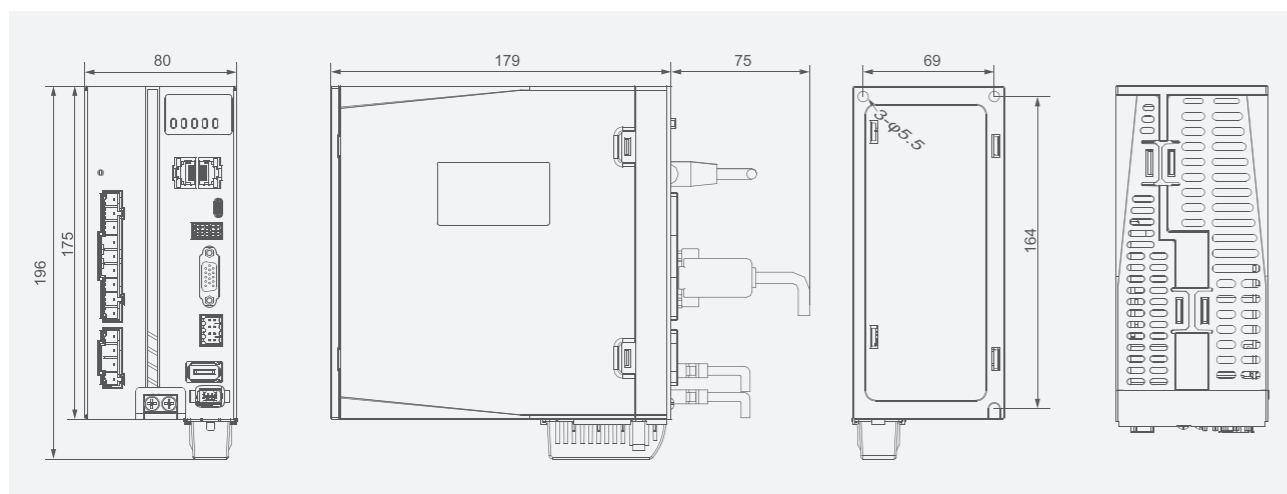

4.4kW/5.5kW/7.5kW (AC 400V)

Unit: mm

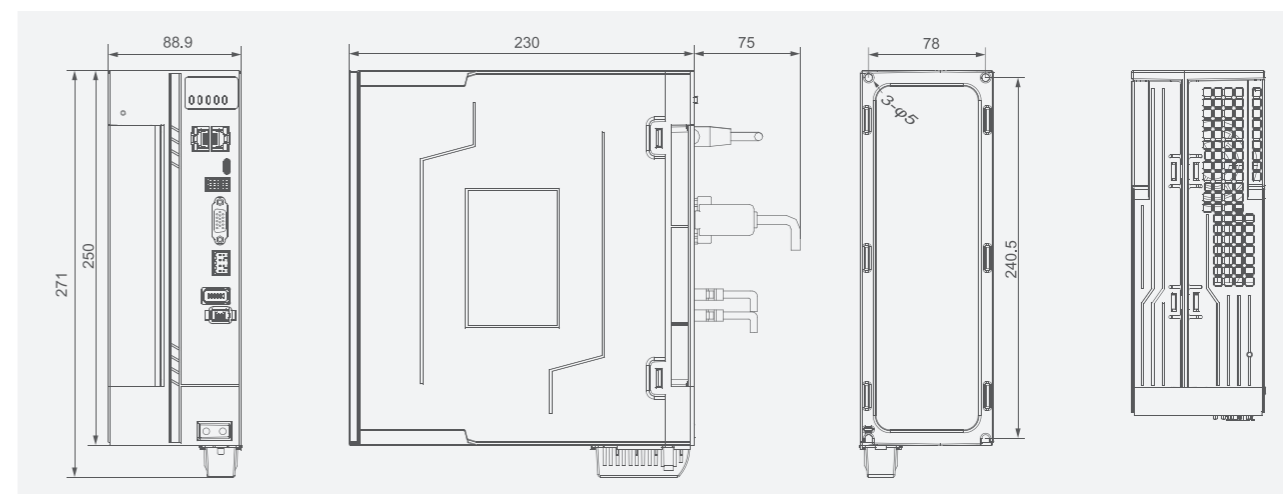



General Purpose EtherCAT AC Servo Drives

EL7-ECF Series

EL7-EC Series AC servo products are high performance economical AC digital servo which is designed for position/velocity/torque high accurate control with power rating ranging up to 1kW for 220VAC models which provides a perfect solution for different applications with easy tuning process.



Part Numbers

EL7 - EC 750 F

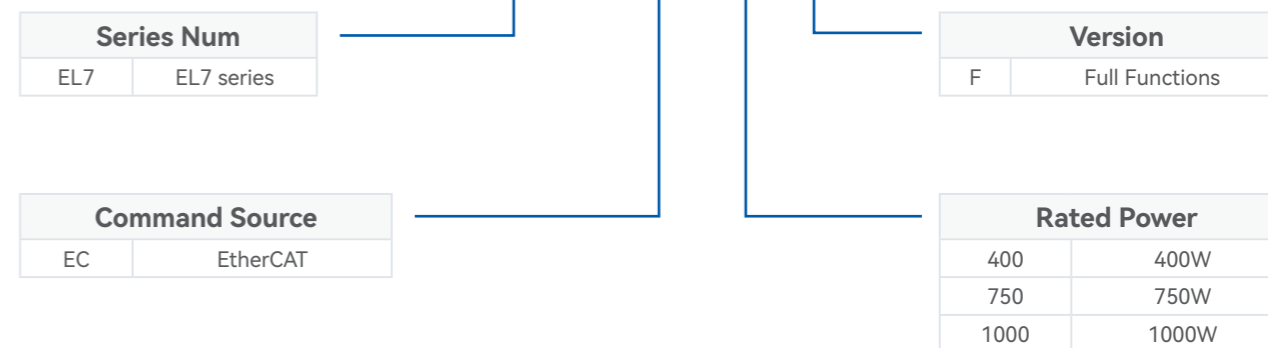

Ports & Connectors

Specifications

○ 1-phase / 3-phase 200-240VAC, 50/60Hz

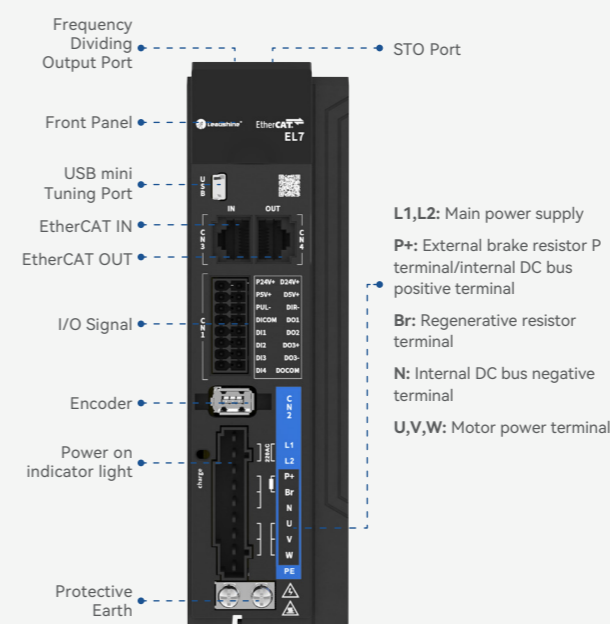

Models	Power rating (W)	Rated current (Arms)	Peak current (Arms)	Dimensions (mm)
EL7-EC400F	400	3.5	9.5	40*175*179
EL7-EC750F	750	5.5	16.6	50*175*179
EL7-EC1000F	1000	7.0	18.7	



General Purpose PROFINET AC Servo Drives

EL7-PN Series

EL7-PN Series AC servo products are high performance AC digital servo which we have proudly developed at Leadshine Technology Co.,Ltd. It is designed for position/velocity/torque high accurate control with power rating ranging from 400W up to 7.5kW.

This driver series supports automatic inertia ratio identification, vibration suppression and automatic/manual gain settings. It also comes with Safe Torque Off (STO) of SIL3 grading and matching regenerative resistor.



Logistics



Packaging



lithium battery



Photovoltaic

Overview

Frequency response

Quicker system response of 3.2kHz for higher precision control.

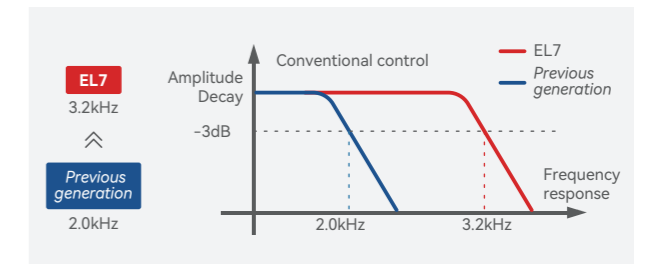

Advanced servo computing

One-Click Tuning - Follow a few easy steps to get servo tuning done. Gain adjustments will be automatically set, shortening tuning time.

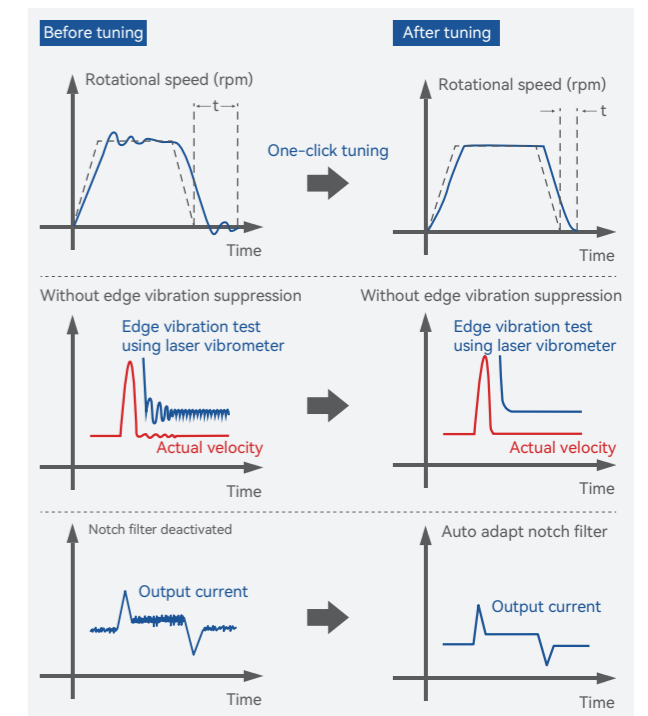

End vibration suppression for flexible structure - suppress low frequency vibration under 200Hz for a quicker and more precise position settling.

Adaptive notch filters - 3 sets of notch filters up to 4kHz for better suppression of structural vibration.

Supports PROFIdrive Telegrams

- Drives with PROFINET communication protocols.
- Supports Application Case 1, 3 and 4.
- Supports Telegram 1, 3, 102, 105, 111.
- Contains Siemens Annex Telegram 750 and Leadshine Annex Telegram 901.



Part Numbers

EL7 - PN 750 F T

Series Num	
EL7	EL7 series

Command Source	
PN	Profinet

Voltage	
Blank	220VAC
T	400VAC

Version	
F	Full Function

Rated Power			
400	400W	750	750W
1000	1000W	1500	1500W
2000	2000W	3000	3000W
4400	4400W	5500	5500W
7500	7500W		

Ports & Connectors

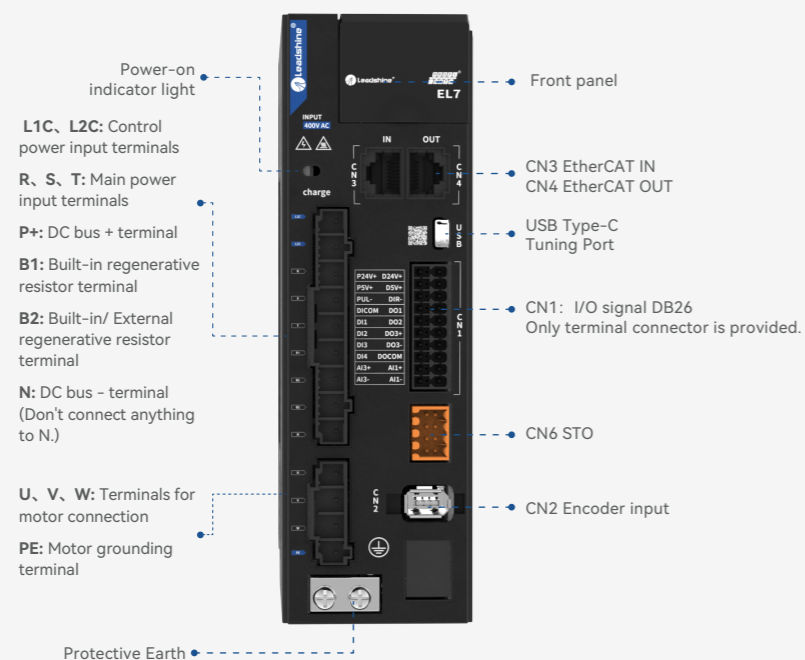

EL7-PN & Peripheral Wiring Diagram

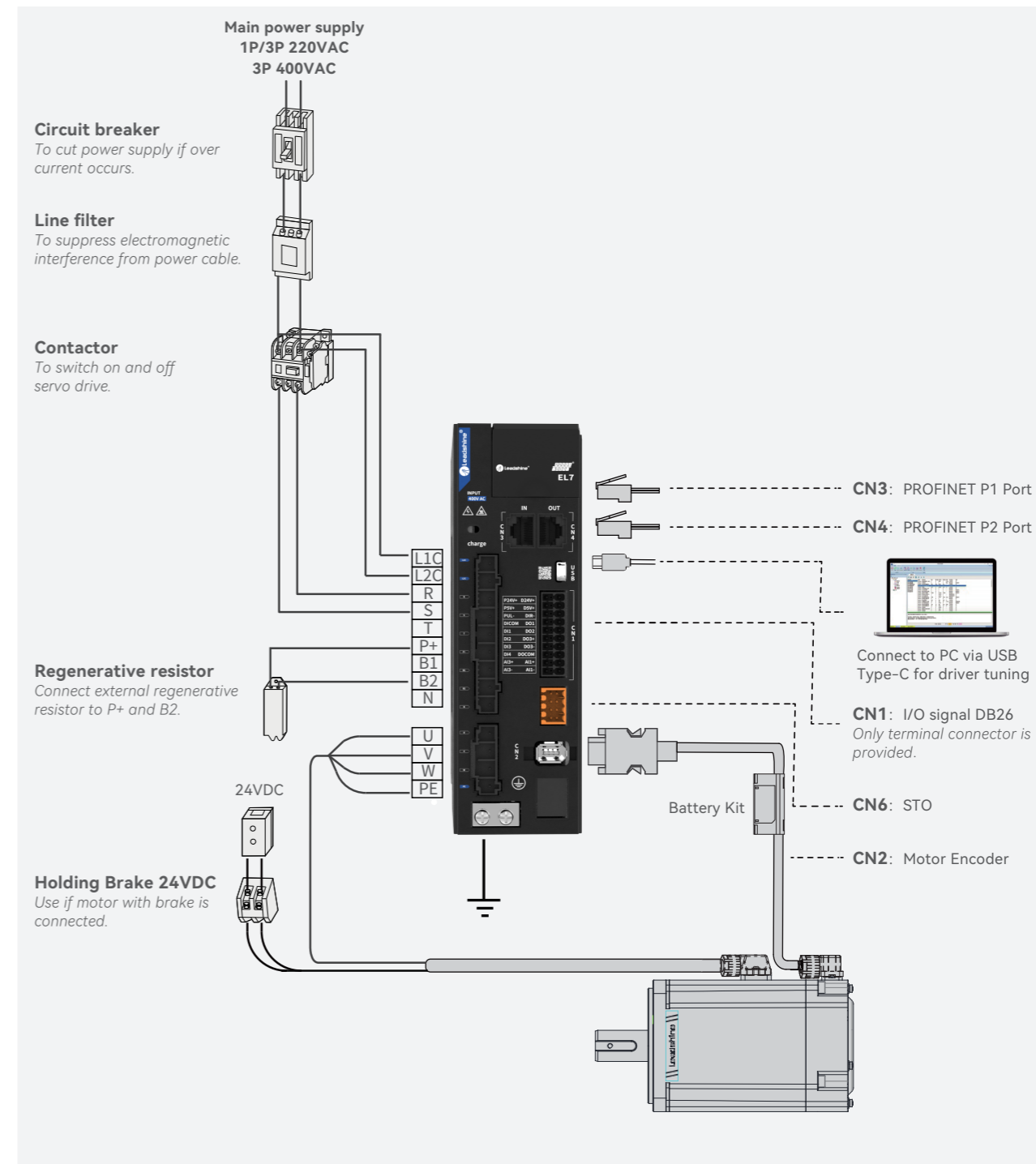

Specifications

EL7-PN 220V Models

EL7- PNF series	EL7-PN400F	EL7- PN750F	EL7- PN1000F	EL7- PN1500F	EL7- PN2000F
Rated power (W)	400	750	100	1500	2000
Rated Current (Arms)	3.5	5.5	7	9.5	12
Peak Current (Arms)	9.2	16.6	18.7	31.1	36
Main Power Supply	Single phase AC 220V, -15%~+10%, 50/60Hz				
Control Circuit Power Supply					
Dimension H*L*W(mm)	175*179*55			175*179*80	

EL7-PN 400V Models

EL7- PNFT series	EL7- PN750FT	EL7- PN1000FT	EL7- PN1500FT	EL7- PN2000FT	EL7- PN3000FT	EL7- PN4400FT	EL7- PN5500FT	EL7- PN7500FT
Rated Power(W)	750	1000	1500	2000	3000	4400	5500	7500
Rated Current (Arms)	2.7	3.5	5.4	8.4	11.9	16.5	20.8	25.7
Peak Current (Arms)	8.6	10.6	14.9	24.8	33.2	38.9	51.6	33.6
Main Power Supply	Three phase AC 380V~440V, -15%~+10%, 50/60Hz							
Control Circuit Power Supply	Single phase AC 380V~440V, -15%~+10%, 50/60Hz							
Dimension L*H*W(mm)	175*179*55		175*179*80			250*230*89		

Ports	Descriptions
USB Type-C Tuning	Modify or read driver parameters without connecting to main power supply
Crossover Frequency Output	Supports phase A/B/Z differential crossover frequency output Supports phase Z open collector crossover frequency output
Digital I/O	8 Digital Inputs (Supports common anode or cathode connection) DI1~DI8 5 digital outputs (double-ended) DO1~DO5
Communication Port	PROFINET protocol (RJ45 port)
Control Mode	
Supported Telegram	Telegram 1/2/3/110/111/102/105

Control Features	
Drive Mode	IGBT SVPWM sinusoidal wave drive
Encoder feedback	Encoder: RS485 Protocol
Easy-to-use	One-click tuning, Single parameter tuning, Black box, Zero tracking control
Notch Filter	Mechanical resonance suppression. Supports up to 3 filters,50Hz~4000Hz
Vibration suppression	End vibration suppression
Alarm	Overcurrent. Overvoltage. Undervoltage. Overheat. Overload. Overtravel. Single-Phasing. Regenerative resistor error. Position deviation error. Encoder feedback error. Excessive braking rate. EEPROM error
Safe Torque Off (STO) function	Available for all EL7-PNF series products
Front Panel	5 push buttons, 8-segments display
Software	Driver tuning through Motion Studio Ver. 2.x.
Dynamic Brake	Internal dynamic brake
Black Box	Set triggering conditions and analyze the data from black box. Used for error solving
Environmental requirements	
Temperature	Storage: -20~80°C (Condensation free); Not < 72 hours if stored in over 65°C Installation: 0~55°C (Not frozen); Lower performance at over 45°C
Humidity	Under 90%RH (Condensation free)
Altitude	Max. altitude of 2000m; 100% performance at 1000m or below. Performance decreases by 1% with every increase of 100m from 1000m.
Vibration	Less than 0.5G (4.9m/s ²) 10~60Hz (non-continuous working)
IP ratings	IP20



Economical AC Servo Drives

EL6-RS Series

EL6 Series include cost-effective AC servo drives designed for accurate positioning control. They can power up to 1kW AC servo motors and are ideal for many OEM applications. Many advanced features are implemented such as MFC, vibration suppression, Multi - mode filter function, etc.

When combined with Leadshine servo motors with 17 or 23-bit high resolution encoders, they can provide excellent performance to your control systems.



Logistics



Packaging



lithium battery



Photovoltaic

Overview

Adaptive Notch Filter

- 4 Adaptive Notch Filter.
- Automatically / Manually Notch Filter Setting.
- Notch Width Selectable.
- Quick setting suppresses mechanical vibration, saving labor cost.

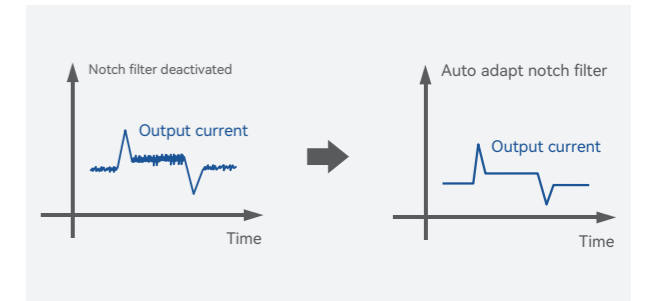

Anti-Vibration Filter

For mechanical equipment with lower stiffness, it is easy to produce low frequency vibration of less than 200Hz, which can be inhibited by mechanical end swing suppression, to realize the high-tempo operation of the equipment.

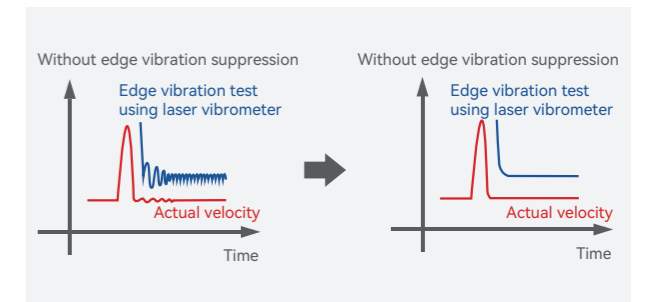

P-N Junction

Directly connect the DC link circuit of entire servo drives to exchange power.

In a system having a powering (driving) shaft and regenerating (back tension) shaft such as the winder/unwinder unit, the power consumption of the entire system can be reduced.

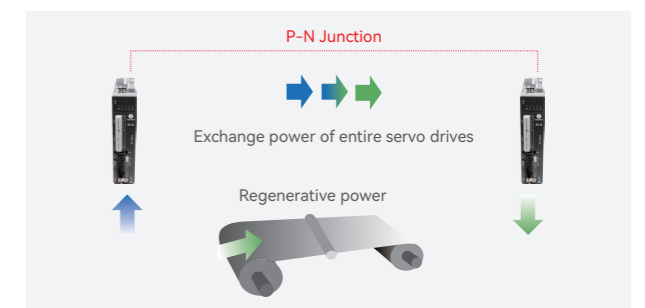

PR-Mode

EL6-RS series embedded with 16 paths motion which setup internally, combined with position/velocity/homing/Jog/E-Stop/Limit switch.

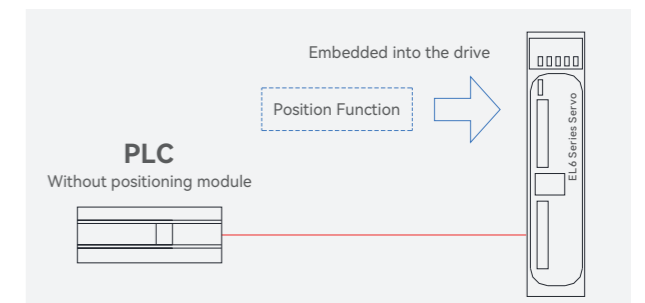

Part Numbers

EL6 - RS 750 P

Series Num	
EL6	EL6 series

Command Source	
RS	Modbus RTU/ Pulse+Direction

Version	
P	Full functions without STO

Rated Power	
400	400W
750	750W
1000	1000W

400W (AC 220V)

Unit: mm

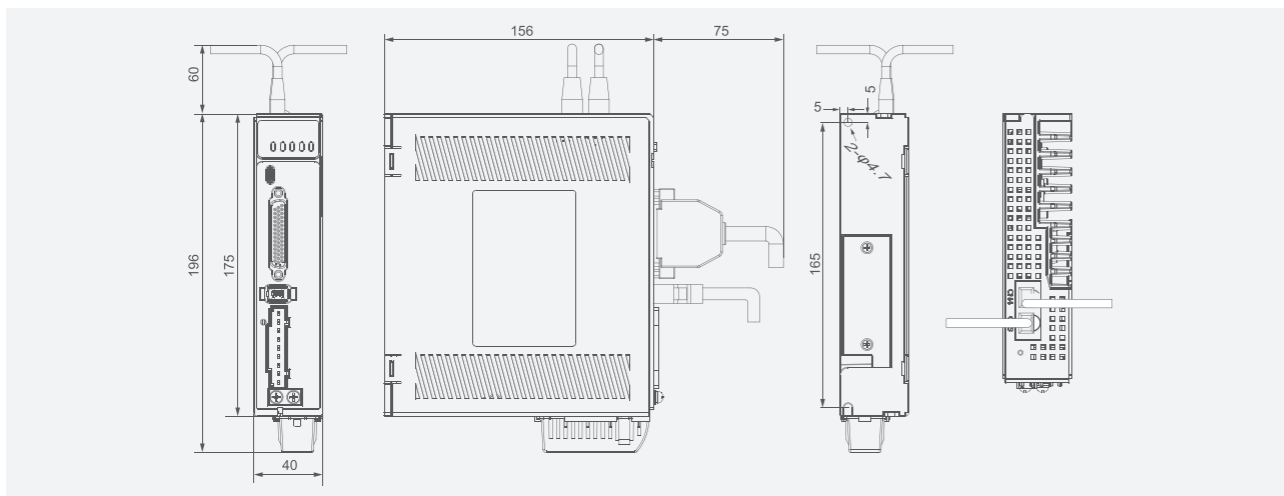

750W/1000W (AC 220V)

Unit: mm

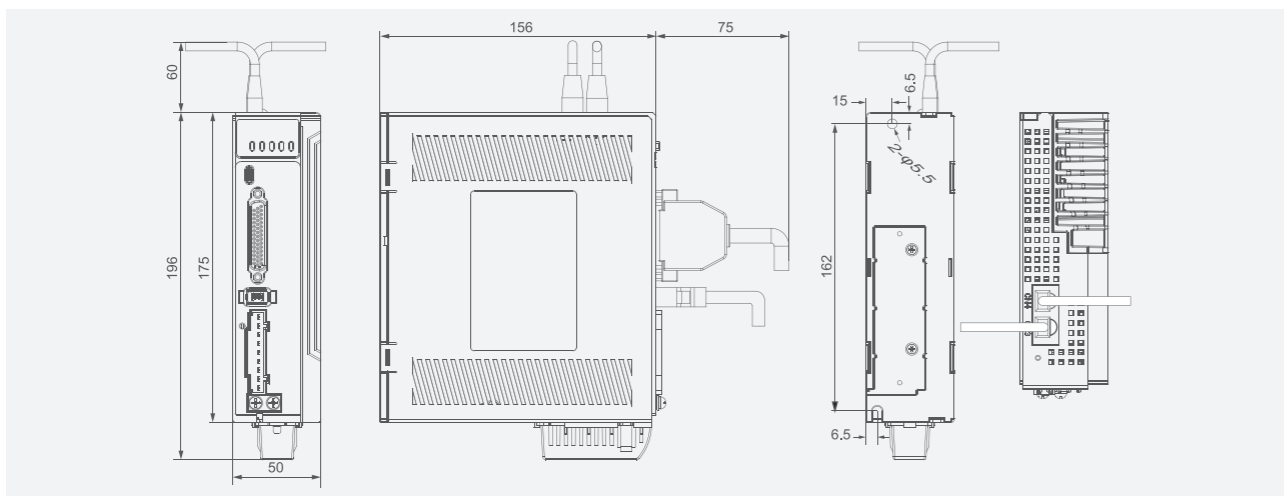

EL6-RS & Peripheral Wiring Diagram

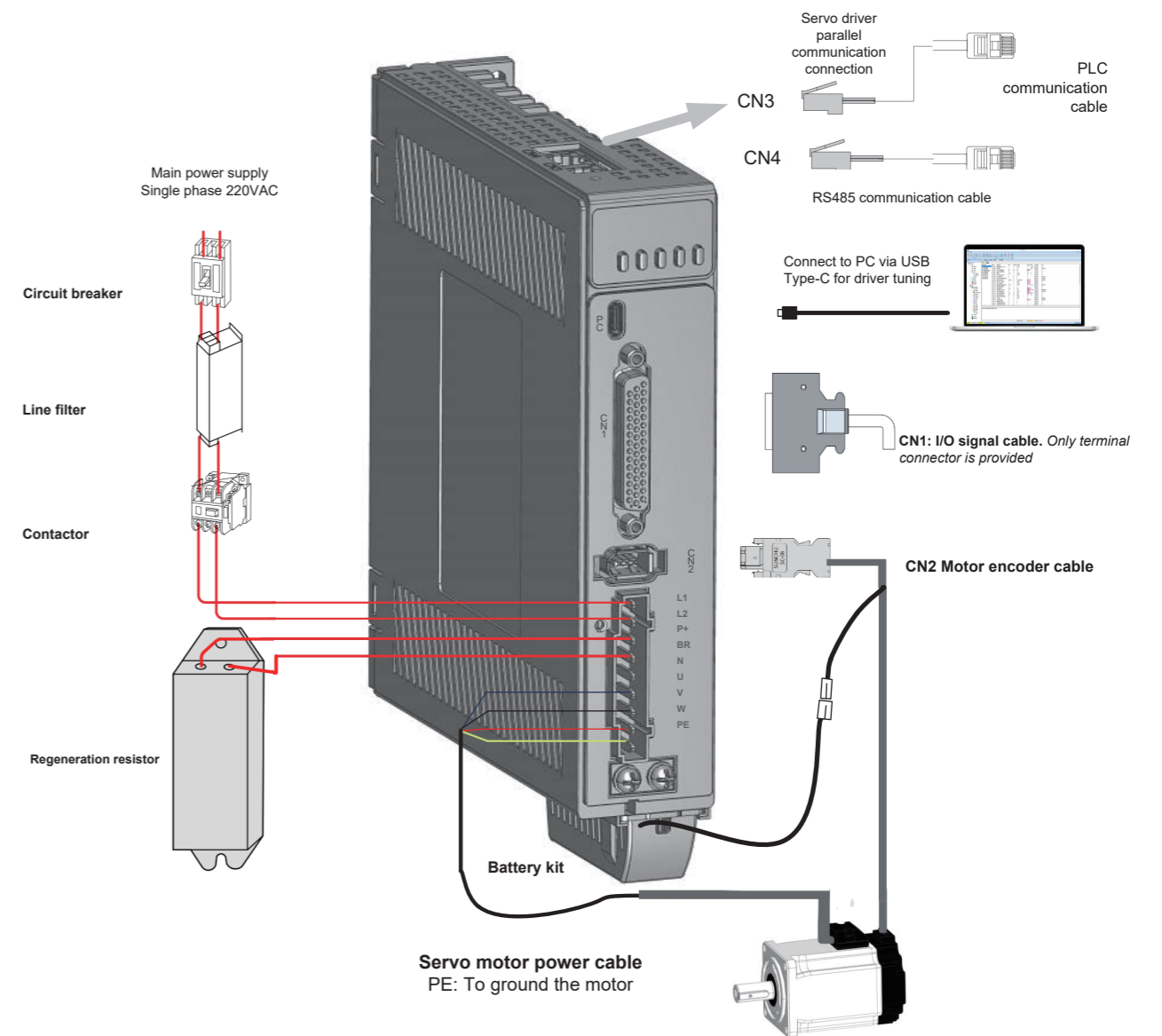

 Specifications

o **EL6-RS 220V Models**

EL6-RSP Series Drive	EL6-RS400P	EL6-RS750P	EL6-RS1000P
Power Rating	400W	750W	1000W
Rated Current (Arms)	3.5	5.5	7.0
Peak Current (Arms)	9.5	16.6	18.7
Control circuit power supply	1-Ph AC 200V-240V, -10% - +10%, 50/60Hz		
Main power supply			
Dimension L*H*W(mm)	175*156*40	175*156*50	

Ports	Descriptions
USB Type-C Tuning	Modify or read driver parameters without connecting to main power supply
Low-speed pulse input	5V differential signal, 0-500kHz 24V single ended signal, 0-200kHz
High-speed pulse input	5V differential signal, 0-4MHz
Crossover Frequency Output	Supports phase A/B/Z differential crossover frequency output Supports phase Z open collector crossover frequency output
Digital I/O	9 Digital Inputs (Supports common anode or cathode connection) DI1~DI8 5 digital outputs (double-ended) DO1~DO5
Communication Port	RS485 communication, Modbus RTU protocol (RJ45 port)
Control Mode	
Control	1. External pulse train position control 2. JOG control
Control Features	
Drive Mode	IGBT SVPWM sinusoidal wave drive
Feedback Method	Encoder: RS485 Protocol
Easy-to-use	One-click tuning, Single parameter tuning, Black box, Zero tracking control
Notch Filter	Mechanical resonance suppression. Supports up to 3 filters, 50Hz~4000Hz
Vibration suppression	End vibration suppression
Alarm	Overcurrent. Overvoltage. Undervoltage. Overheat. Overload. Overtravel. Single-Phasing. Regenerative resistor error. Position deviation error. Encoder feedback error. Excessive braking rate. EEPROM error
Front Panel	5 push buttons, 8-segments display
Software	Driver tuning through Motion Studio Ver. 2.x

Software	Driver tuning through Motion Studio Ver. 2.x
Dynamic Brake	Internal dynamic brake
Black Box	Set triggering conditions and analyze the data from black box. Used for error solving
Environmental requirements	
Temperature	Storage: -20-80°C (Condensation free); Not < 72 hours if stored in over 65°C Installation: 0-55°C (Not frozen); Lower performance at over 45°C
Humidity	Under 90%RH (Condensation free)
Altitude	Max. altitude of 2000m; 100% performance at 1000m or below. Performance decreases by 1% with every increase of 100m from 1000m.
Vibration	Less than 0.5G (4.9m/s ²) 10-60Hz (non-continuous working)
IP ratings	IP20



Economical AC Servo Drives

EL6-CAN Series

EL6-CAN Series is cost-effective AC servo drives of CANopen protocol designed for accurate control. They can power to 1kW AC servo motors and are ideal for many OEM applications. Many advanced features are implemented such as MFC, vibration suppression, multi filter functions, etc.

When combined with Leadshine servo motors with 23-bit high resolution encoders, they can provide excellent performance to your control systems.



Logistics



Packaging



lithium battery



Photovoltaic

EL6-CAN & Peripheral Wiring Diagram

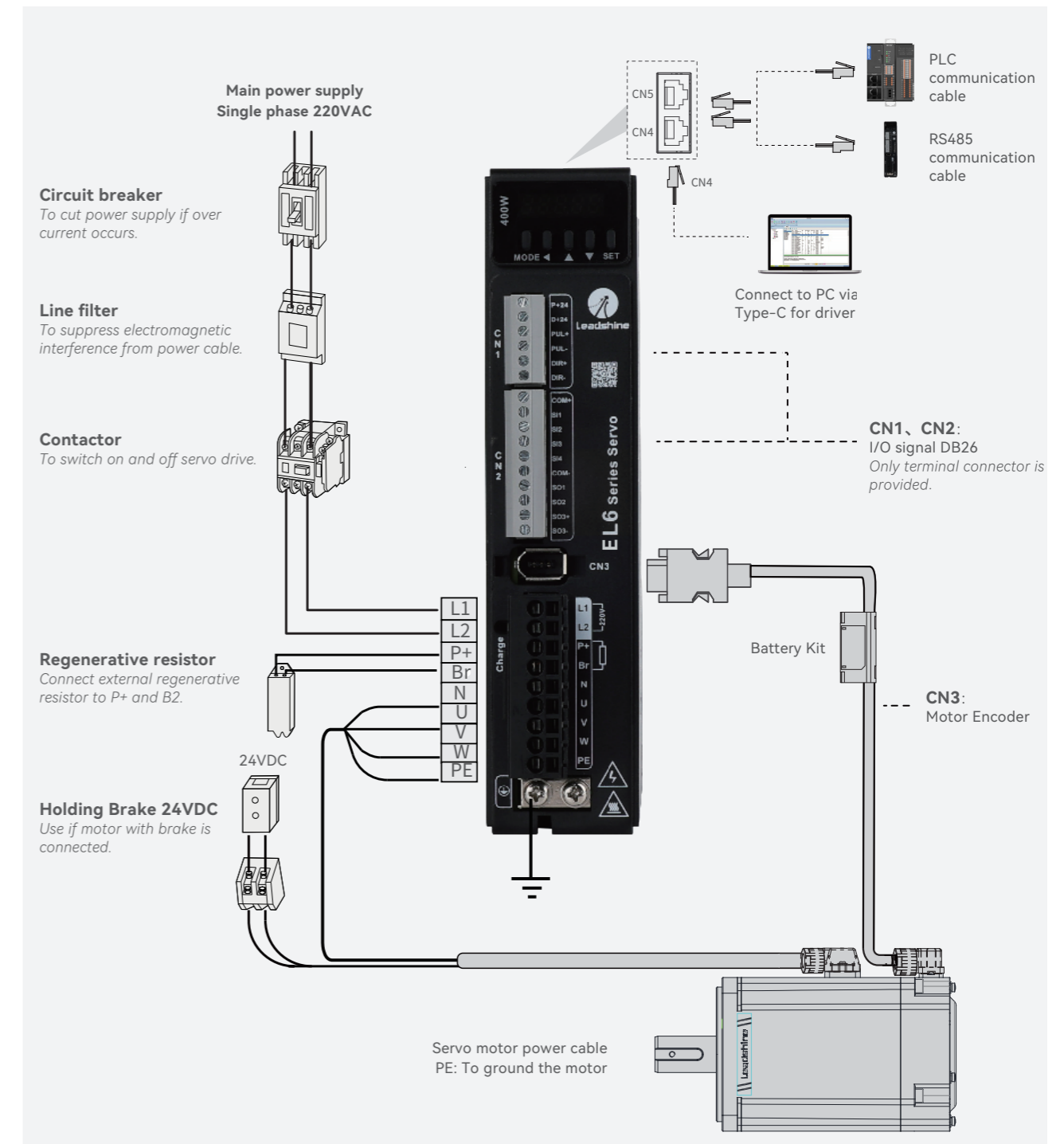

Part Numbers

EL6 - CAN 400 Z

Series Num		Version	
EL6	EL6 servo drive series	Z	Standard Version
Command Source		Rated Power	
CAN	CANopen	400	400W
		750	750W
		1000	1000W

400W (AC 220V)

Unit: mm

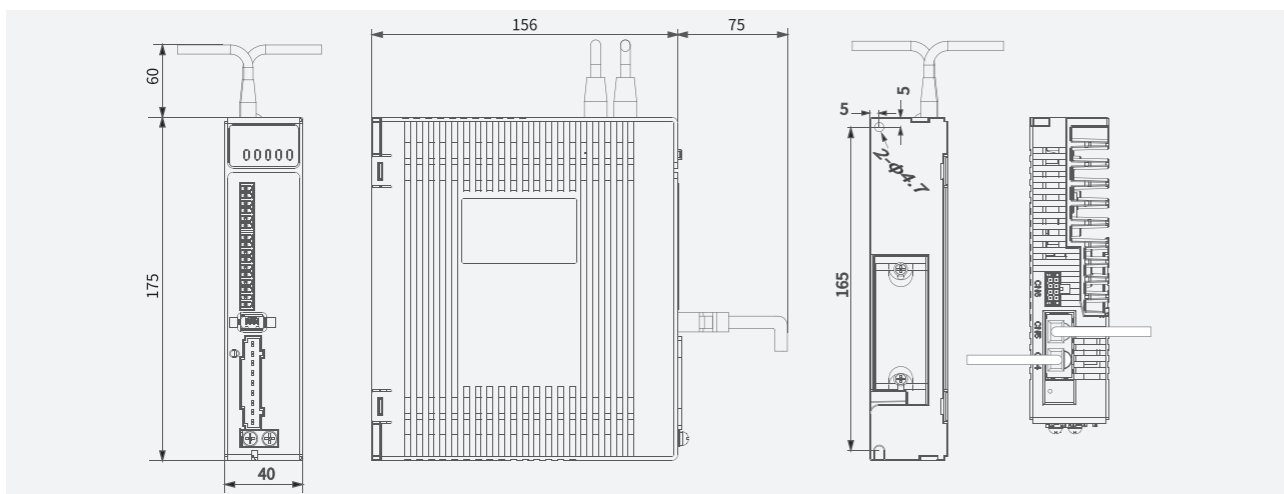

750W/1000W (AC 220V)

Unit: mm

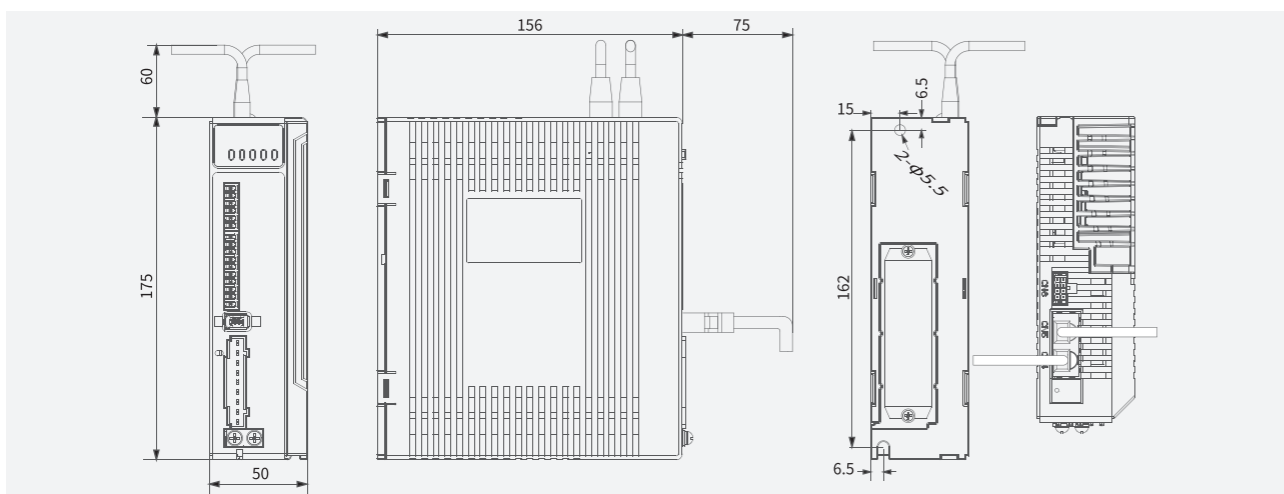

Specifications

o **EL6-CAN 220V Models**

EL6-CAN Series Drive	EL6-CAN400Z	EL6-CAN750Z	EL6-CAN1000Z
Power Rating	400W	750W	1000W
Rated Current (Arms)	3.5	5.5	7.0
Peak Current (Arms)	9.5	16.6	18.7
Control circuit power supply	1-Ph AC 200V~240V, -10% - +10%, 50/60Hz		
Main power supply	1-Ph AC 200V~240V, -10% - +10%, 50/60Hz		
Dimension L*H*W(mm)	175*156*40	175*156*50	

Ports	Descriptions
RJ45 Tuning	Modify or read driver parameters
Crossover Frequency Output	Supports phase A/B/Z differential crossover frequency output Supports phase Z open collector crossover frequency output
Digital I/O	4 Digital Inputs (Supports common anode or cathode connection) DI1~DI8 3 digital outputs (double-ended) DO1~DO5
Communication Port	CANopen protocol (RJ45 port)
Control Mode	
Control	1. Profile Position Mode 2. Profile Velocity Mode 3. Profile Torque Mode 4. Homing Mode
Control Features	
Drive Mode	IGBT SVPWM sinusoidal wave drive
Feedback Method	Encoder: RS485 Protocol
Notch Filter	Mechanical resonance suppression. Supports up to 3 filters, 50Hz~4000Hz
Vibration suppression	End vibration suppression
Alarm	Overcurrent. Overvoltage. Undervoltage. Overheat. Overload. Overtravel. Single-Phasing. Regenerative resistor error. Position deviation error. Encoder feedback error. Excessive braking rate. EEPROM error
Front Panel	5 push buttons, 8-segments display
Software	Driver tuning through Motion Studio Ver. 2.x
Dynamic Brake	Internal dynamic brake
Environmental requirements	
Temperature	Storage: -20~80°C (Condensation free); Not < 72 hours if stored in over 65°C Installation: 0~55°C (Not frozen); Lower performance at over 45°C
Humidity	Under 90%RH (Condensation free)
Altitude	Max. altitude of 2000m; 100% performance at 1000m or below. Performance decreases by 1% with every increase of 100m from 1000m.
Vibration	Less than 0.5G (4.9m/s ²) 10~60Hz (non-continuous working)
IP ratings	IP20

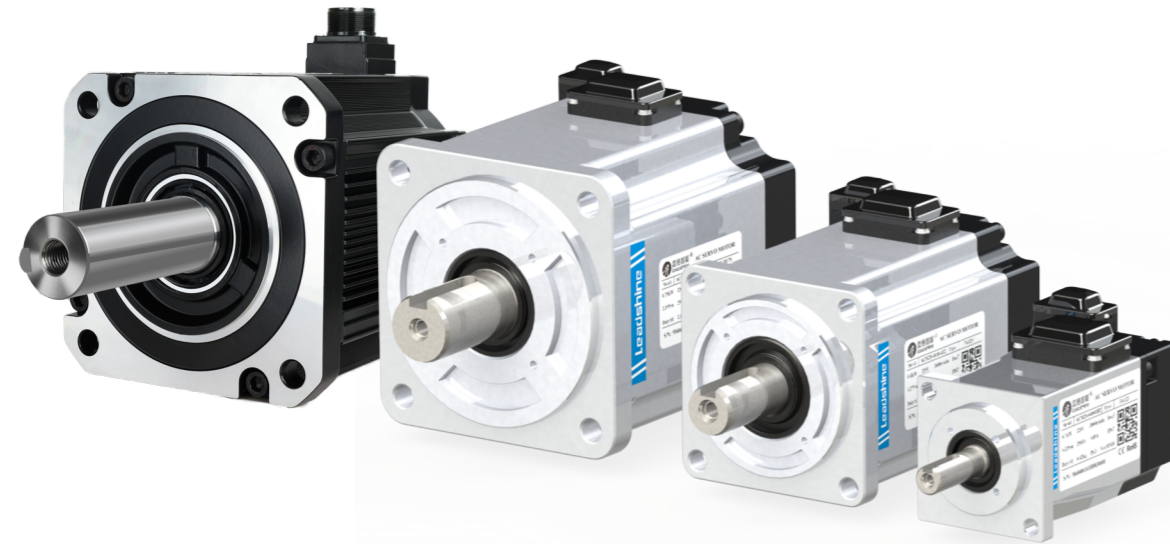

AC Servo Motors

ELM1/ELM2 Series

Feature:

- Power rating: 30W-7.5kW
- Voltage: 220VAC/400VAC
- Encoder: 23-bit encoder
- Optional accessory: brake
- Frame size: 25mm,40mm,60mm,80mm,100mm,130mm,180mm.

ELM1 Series

23-Bit magnetic encoder
Power: 50W-1800W

ELM2 Series

23-Bit optical encoder
Power: 30W-7500W

Overview

Precision positioning

High inertia, high torque with overloading up to 350%, rotational speed up to 6500rpm with acceleration at the max. of 2g.

Positioning accuracy of 0.02mm and precision of 0.01mm thanks to 3.2kHz frequency response and 5Mbps communication rate.

High quality servo motor

IP rating of IP67 with better performance and reliability.

Motor comes with direct connectors which is easier for installation and more reliable.

Servo motor

Better reliability with IP ratings of IP67 in addition to higher max. speed/torque and overload rate up to 350%.

Better motor stability

Improving the stability of high and low velocity motion by 30%.

ENCODER **COMMUNICATION RATE**

23-bit
Optical/Magnetic
*1310608 Pulses/Rotation

5 Mbps

65 times higher resolution + **100% increased** =

- Great vibration suppression
- High positioning precision

**Comparing to previous gen. 17-bit servo motors*

Splash **Moisture** **Submerged**

Overload 350%

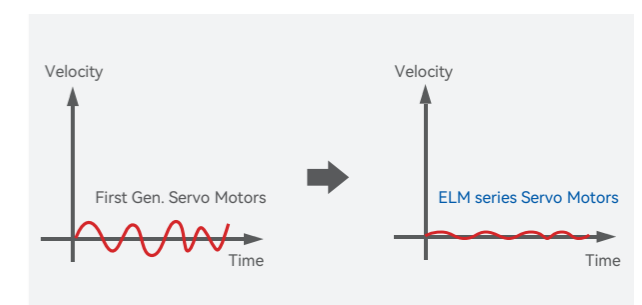



Part Numbers

ELM2 H - 0850 L D 130 E T - H

(1) (2) (3) (4) (5) (6) (7) (8) (9)

(1) Series Num

ELM1	ELM1 Series servo motor
ELM2	ELM2 Series servo motor

(2) Inertia Ratio

L	Low
M	Medium
H	High

(3) Rated Output Power

0030	30W	2000	2000W
0050	50W	2900	2900W
0100	100W	3000	3000W
0200	200W	3800	3800W
0400	400W	4000	4000W
0750	750W	4400	4400W
0850	850W	5000	5000W
1300	1300W	7000	7000W
1800	1800W	7500	7500W
1500	1500W		

(4) Encoder Type

L	23-bit optical multi-turn
M	23-bit magnetic multi-turn
N	26-bit optical multi-turn
F	17-bit magnetic
D	17-bit optical

(5) Rated Speed

A	3000rpm	B	2500rpm
C	2000rpm	D	1500rpm
E	1000rpm		

(9) Connect type

Blank	Direct connector
H	Aviation connector-H

(8) Voltage

Blank	220VAC
T	400VAC

(7) Motor Type

E	With brake, oil seal
F	No brake, oil seal

(6) Frame Size

25	25mm
40	40mm
60	60mm
80	80mm
100	100mm
130	130mm
180	180mm

25mm Frame size & 30W

Type Name	Frame Size (mm)	Brake	Voltage (VAC)	Power (W)	Speed (rpm)		Torque (Nm)		Current (Arms)		Permissible load to shaft (N)		Encoder	Inertia (kgm ² *10 ⁻⁴)	Weight (kg)	Motor Length (mm)
					Rated	Max	Rated	Max	Rated	Max	Radial	Axial				
ELM2L-0030LA25E	□ 25	√	220	30	3000	6000	0.105	0.315	0.87	2.6	44	14.5	23-bit optical encoder	0.007	0.26	98.5
ELM2L-0030LA25F		x														

Speed-Torque characteristics

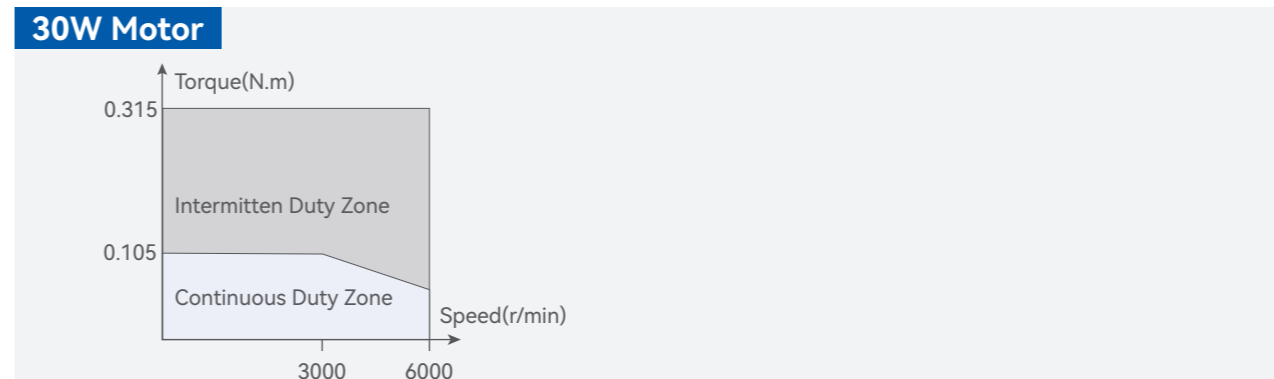

Dimensions

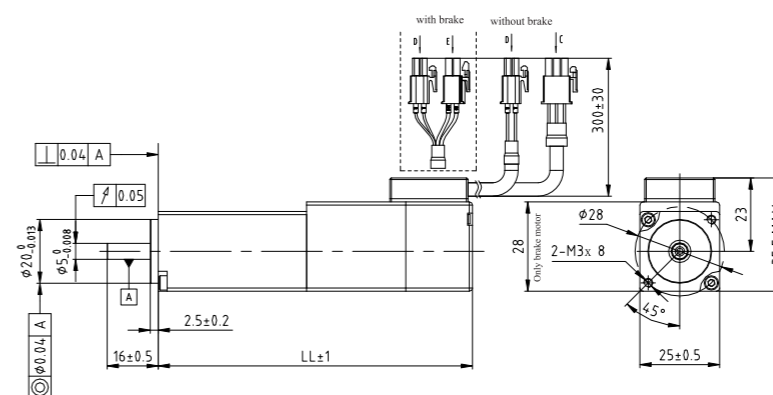

Motor model	LL
ELM2L-0030LA25E	98.5
ELM2L-0030LA25F	72.5

40mm Frame size & 50W~100W

Type Name	Frame Size (mm)	Brake	Voltage (VAC)	Power (W)	Speed (rpm)		Torque (Nm)		Current (Arms)		Permissible load to shaft (N)		Encoder	Inertia (kgm ² *10 ⁻⁴)	Weight (kg)	Motor Length (mm)				
					Rated	Max	Rated	Max	Rated	Max	Radial	Axial								
ELM1H-0050MA40E	□ 40	√	220	50	3000	5000	0.16	0.48	0.93	2.88	78	54	23-bit magnetic encoder	0.046	0.44	84				
ELM1H-0050MA40F		×												0.036	0.28	56.7				
ELM1H-0100MA40E		√												0.32	0.96	0.92	2.85	0.072	0.54	95
ELM1H-0100MA40F		×																		
ELM2H-0050LA40E		√		50			23-bit optical encoder	0.046	0.44	84										
ELM2H-0050LA40F		×						0.036	0.28	56.7										
ELM2H-0100LA40E		√						0.32	0.96	0.92				2.85	0.072	0.54	95			
ELM2H-0100LA40F		×																0.062	0.38	67.7

Speed-Torque characteristics

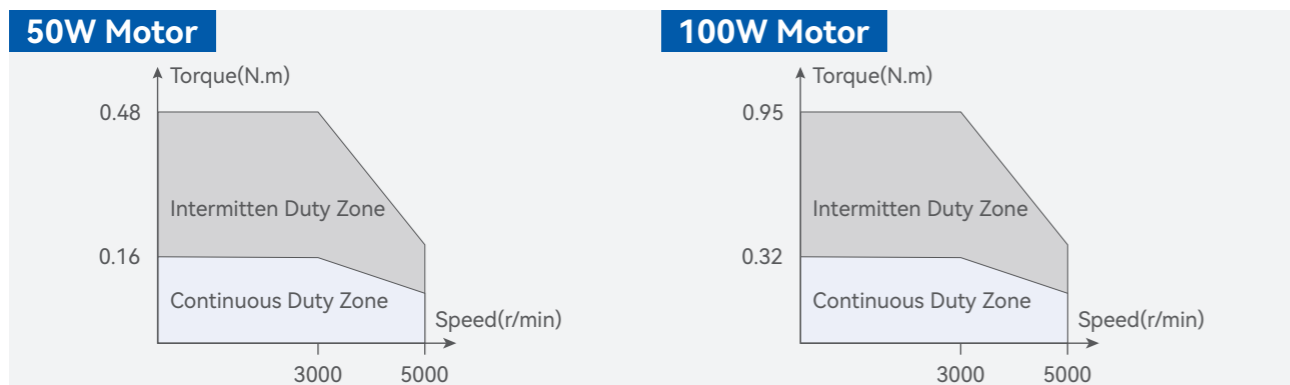

Dimensions

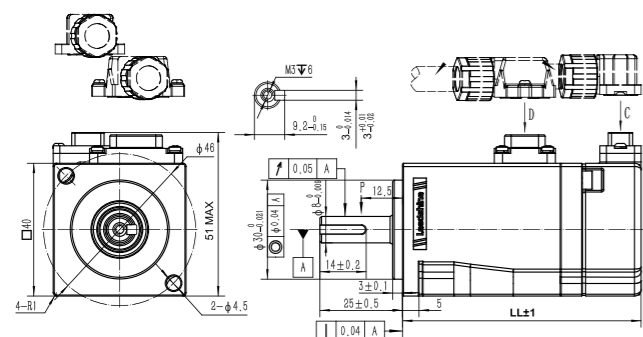

Motor model	LL
ELM*H-0050*A40E	84
ELM*H-0050*A40F	56.7
ELM*H-0100*A40E	95
ELM*H-0100*A40F	67.7

60mm Frame size & 200W~400W

Type Name	Frame Size (mm)	Brake	Voltage (VAC)	Power (W)	Speed (rpm)		Torque (Nm)		Current (Arms)		Permissible load to shaft (N)		Encoder	Inertia (kgm ² *10 ⁻⁴)	Weight (kg)	Motor Length (mm)
					Rated	Max	Rated	Max	Rated	Max	Radial	Axial				
ELM1H-0200MA60E	□ 60	√	220	200	3000	5000	0.64	1.92	1.5	4.5	245	74	23-bit magnetic encoder	0.3	1.3	101.1
ELM1H-0200MA60F		×												0.28	1.0	71.8
ELM1H-0400MA60E		√												0.58	1.55	118.1
ELM1H-0400MA60F		×														
ELM2H-0200LA60E		√		200			23-bit optical encoder	0.3	1.3	101.1						
ELM2H-0200LA60F		×						0.28	1.0	71.8						
ELM2H-0400LA60E		√						0.58	1.55	118.1						
ELM2H-0400LA60F		×												0.56	1.3	88.8

Speed-Torque characteristics

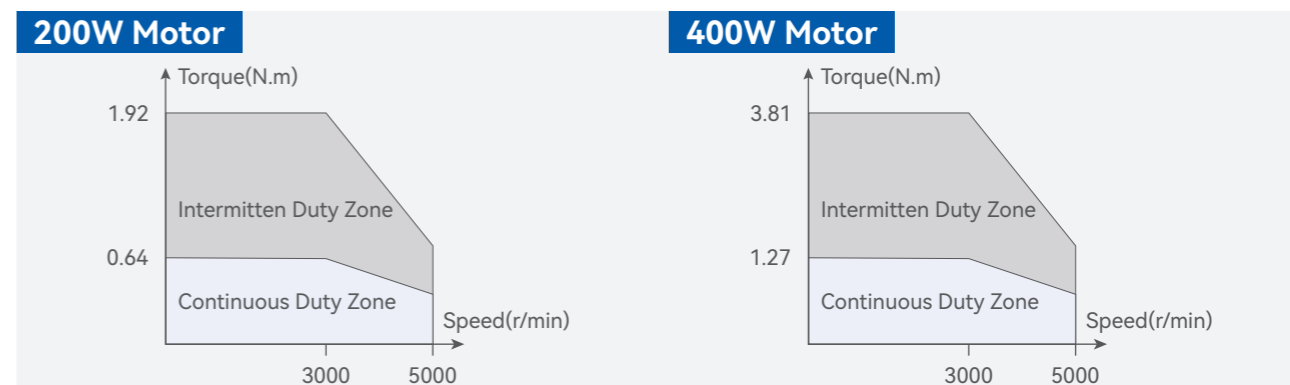

Dimensions

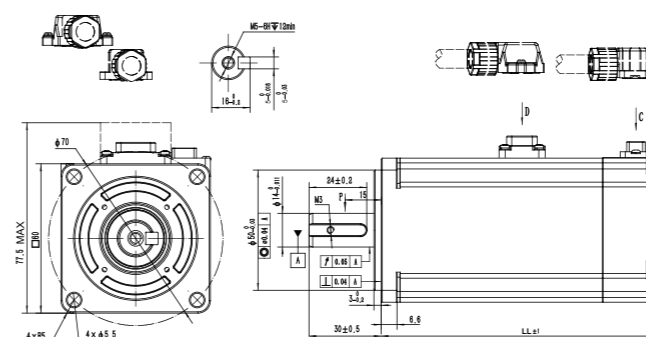

Motor model	LL
ELM*H-0200*A60E	101.1
ELM*H-0200*A60F	71.8
ELM*H-0400*A60E	118.1
ELM*H-0400*A60F	88.8

200W~750W

Type Name	Frame Size (mm)	Brake	Voltage (VAC)	Power (W)	Speed (rpm)		Torque (Nm)		Current (Arms)		Permissible load to shaft (N)		Encoder	Inertia (kgm ² *10 ⁻⁴)	Weight (kg)	Motor Length (mm)
					Rated	Max	Rated	Max	Rated	Max	Radial	Axial				
ELM2L-0200LA60E	□ 60	√	220	200	3000	6500	0.64	2.23	1.5	5.7	245	74	23-bit optical encoder	0.15	1.2	101.2
ELM2L-0200LA60F		x												0.14	0.85	71.8
ELM2L-0400LA60E		√												0.26	1.54	118.2
ELM2L-0400LA60F		x												0.25	1.19	88.8
ELM2L-0750LA80E	□ 80	√	220	750	3000	5000	2.39	8.36	4.2	16.1	392	147	23-bit optical encoder	0.79	2.74	121.9
ELM2L-0750LA80F		x												0.77	2.12	90.9

Speed-Torque characteristics

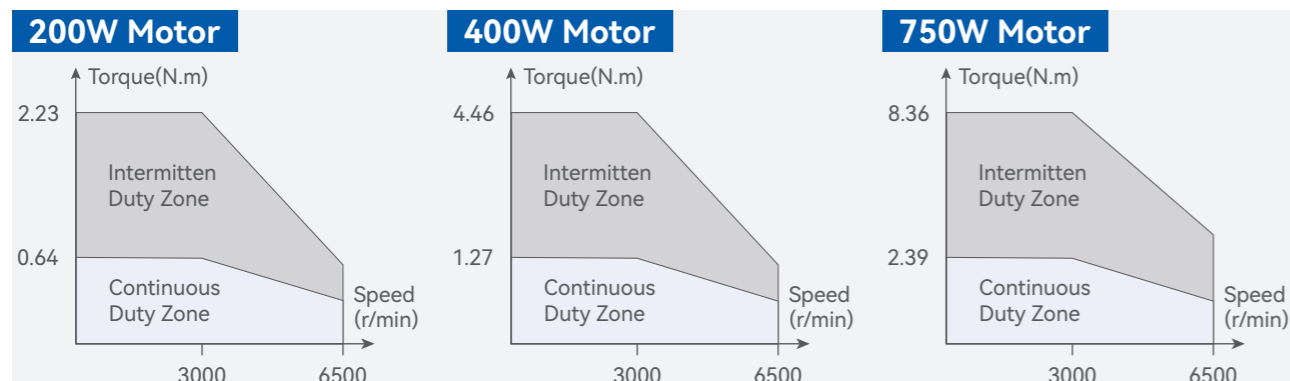

Dimensions

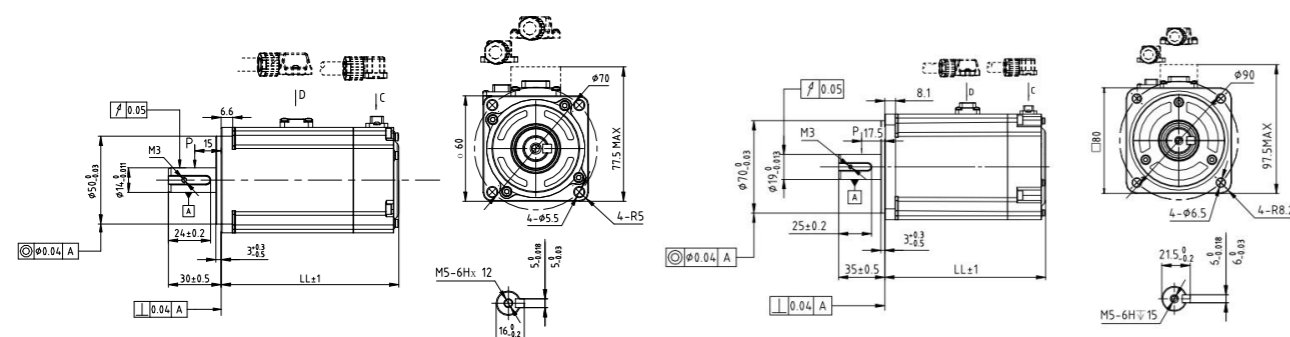

Motor model	LL	Motor model	LL
ELM2L-0200LA60E	101.2	ELM2L-0400LA60E	118.2
ELM2L-0200LA60F	71.8	ELM2L-0400LA60F	88.8

Motor model	LL
ELM2L-0750LA80E	121.9
ELM2L-0750LA80F	90.9

80mm Frame size & 750W~1000W

Type Name	Frame Size (mm)	Brake	Voltage (VAC)	Power (W)	Speed (rpm)		Torque (Nm)		Current (Arms)		Permissible load to shaft (N)		Encoder	Inertia (kgm ² *10 ⁻⁴)	Weight (kg)	Motor Length (mm)
					Rated	Max	Rated	Max	Rated	Max	Radial	Axial				
ELM1H-0750MA80E	□ 80	√	220	750	3000	5000	2.39	7.17	4.1	13.4	392	147	23-bit magnetic encoder	1.65	2.7	121.9
ELM1H-0750MA80F		x												1.5	2.12	90.9
ELM1H-1000MA80E		√												2.15	3.4	134.9
ELM1H-1000MA80F		x												2.0	2.8	103.9
ELM2H-0750LA80E	□ 80	√	220	750	3000	5000	2.39	7.17	4.1	13.4	392	147	23-bit optical encoder	1.65	2.7	121.9
ELM2H-0750LA80F		x												1.5	2.12	90.9
ELM2H-1000LA80E		√												2.15	3.4	134.9
ELM2H-1000LA80F		x												2.0	2.8	103.9

Speed-Torque characteristics

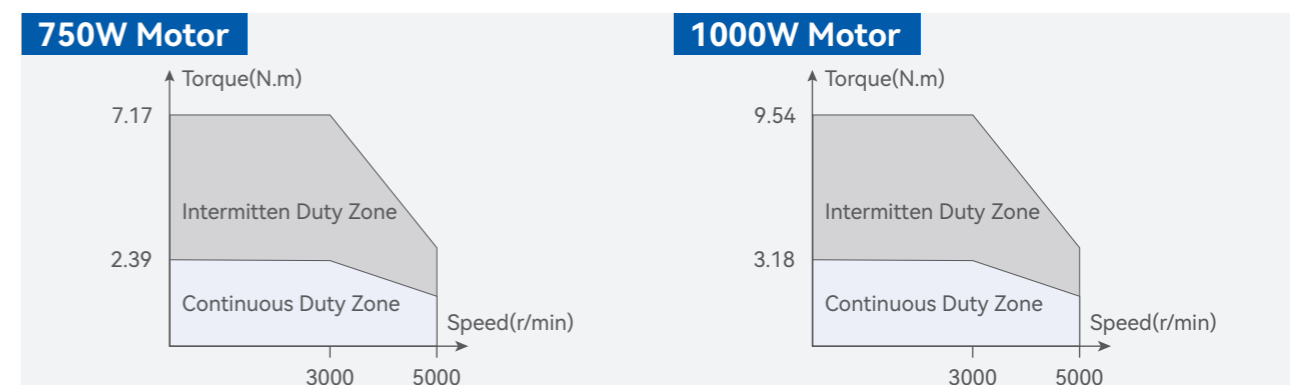

Dimensions

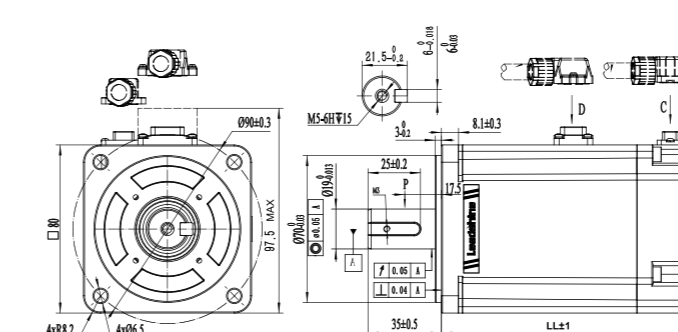

Motor model	LL
ELM*H-0750*A80E	121.9
ELM*H-0750*A80F	90.9
ELM*H-1000*A80E	134.9
ELM*H-1000*A80F	103.9

100mm Frame size & 1000W~1500W

Type Name	Frame Size (mm)	Brake	Voltage (VAC)	Power (W)	Speed (rpm)		Torque (Nm)		Current (Arms)		Permissible load to shaft (N)		Encoder	Inertia (kgm ² *10 ⁻⁴)	Weight (kg)	Motor Length (mm)
					Rated	Max	Rated	Max	Rated	Max	Radial	Axial				
ELM2L-1000LA100E-H	□ 100	√	220	1000	6000	3.2	9.6	6.5	19.5	490	98	23-bit optical encoder	2.63	5.9	194	
ELM2L-1000LA100F-H		x											2.43	4.6	154	
ELM2L-1500LA100E-H		√		1500	5000	4.9	14.7	8	25.5				3.803	7.1	218	
ELM2L-1500LA100F-H		x											3.503	5.8	178	

Speed-Torque characteristics

1000W Motor

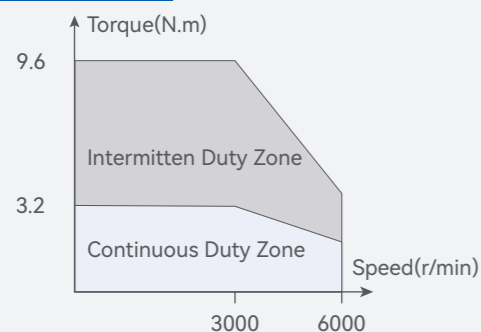

1500W Motor

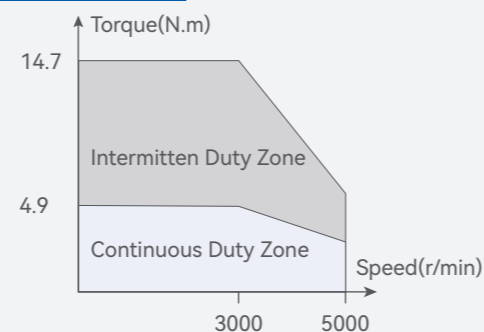

Dimensions

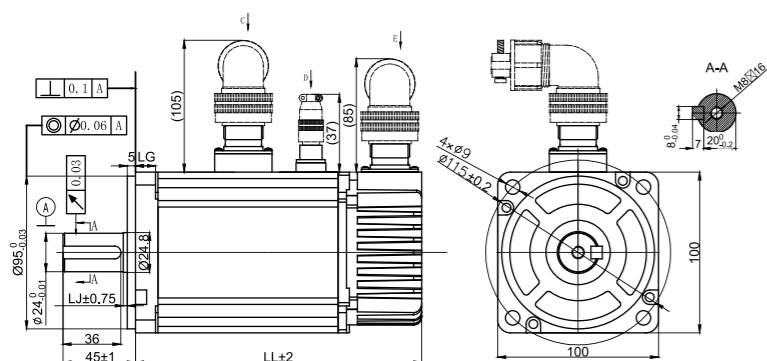

Motor model	LL
ELM2L-1000LA100E-H	194
ELM2L-1000LA100F-H	154
ELM2L-1500LA100E-H	218
ELM2L-1500LA100F-H	178

130mm Frame size & 850W~1800W

Type Name	Frame Size (mm)	Brake	Voltage (VAC)	Power (W)	Speed (rpm)		Torque (Nm)		Current (Arms)		Permissible load to shaft (N)		Encoder	Inertia (kgm ² *10 ⁻⁴)	Weight (kg)	Motor Length (mm)										
					Rated	Max	Rated	Max	Rated	Max	Radial	Axial														
ELM1H-0850MD130E-H	□ 130	√	220	850			5.39	16.17	6.8	20.4	490	98	23-bit magnetic encoder	14.8	6.9	153.5										
ELM1H-0850MD130F-H		x												12.5	5.5	126										
ELM1H-1300MD130E-H		√		1300	1500	4500	8.34	25.02	9.3	27.9	686	343		21	8.4	171.5										
ELM1H-1300MD130F-H		x												18.7	7.0	144										
ELM1H-1800MD130E-H		√		1800			11.5	28.8	11.2	29.3	980	392		26.1	9.7	189.5										
ELM1H-1800MD130F-H		x												23.8	8.3	162										
ELM1M-1500MA130E-H		√		1500	3000	5500	4.9	12.5	6.8	17.1	490	98		14.8	6.9	153.5										
ELM1M-1500MA130F-H		x												12.5	5.5	126										
ELM2H-0850LD130E-H		√		850			5.39	16.17	6.8	20.4	490	98		23-bit optical encoder	14.8	6.9	153.5									
ELM2H-0850LD130F-H		x													12.5	5.5	126									
ELM2H-1300LD130E-H		√													1300	1500	4500	8.34	25.02	9.3	27.9	686	343	21	8.4	171.5
ELM2H-1300LD130F-H		x																						18.7	7.0	144
ELM2H-1800LD130E-H		√													1800			11.5	28.8	11.7	29.3	980	392	26.1	9.7	189.5
ELM2H-1800LD130F-H		x																						23.8	8.3	162

Speed-Torque characteristics

850W Motor

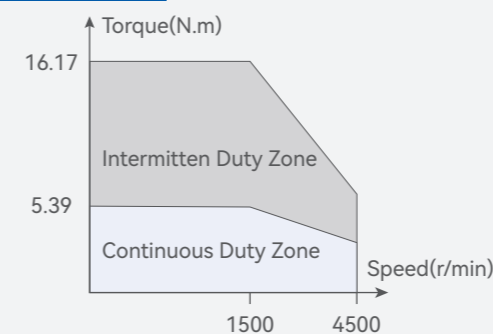

1300W Motor

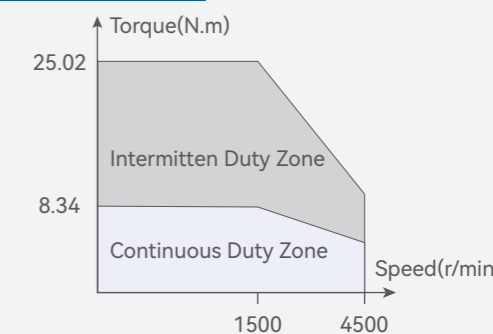

1800W Motor

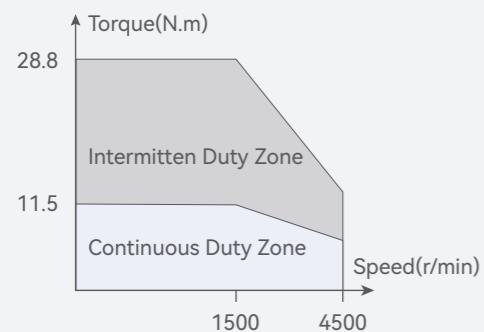

1500W Motor

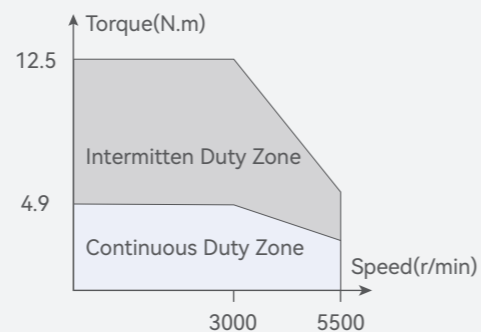

Dimensions

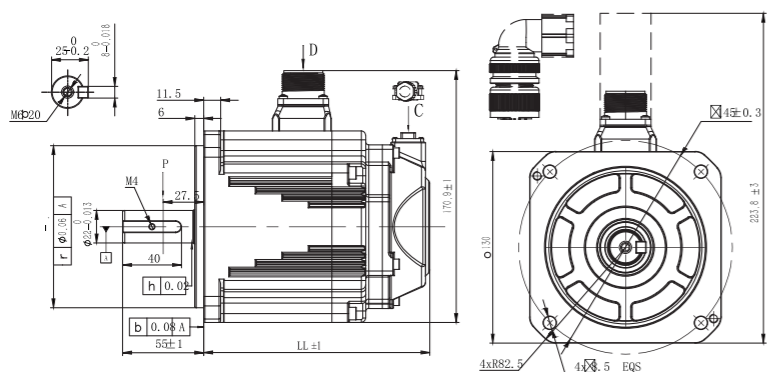

Motor model	LL
ELM*H-0850*D130E-H	153.5
ELM*H-0850*D130F-H	126
ELM*H-1300*D130E-H	171.5
ELM*H-1300*D130F-H	144
ELM*H-1800*D130E-H	189.5
ELM*H-1800*D130F-H	162
ELM1M-1500*A130E-H	153.5
ELM1M-1500*A130F-H	126

130mm Frame size & 1000W~2000W

Type Name	Frame Size (mm)	Brake	Voltage (VAC)	Power (W)	Speed (rpm)		Torque (Nm)		Current (Arms)		Permissible load to shaft (N)		Encoder	Inertia (kgm ² *10 ⁻⁴)	Weight (kg)	Motor Length (mm)	
					Rated	Max	Rated	Max	Rated	Max	Radial	Axial					
ELM2M-1000LB130E-H	□ 130	√	220	1000		4	12	4	12	490	196	23-bit optical encoder		8.95	8.3	223	
ELM2M-1000LB130F-H		×															2500
ELM2M-1500LB130E-H	□ 131	√		1500		6	18	6	18					12.6	9.5	236	
ELM2M-1500LB130F-H		×															12.6
ELM2M-2000LB130E-H	□ 131	√		2000	2500	2800	7.7	22	7.5					22	16.8	11	270
ELM2M-2000LB130F-H		×															

Speed-Torque characteristics

1000W Motor

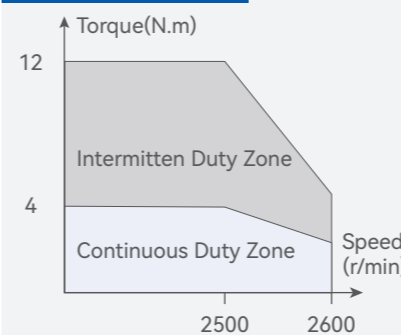

1500W Motor

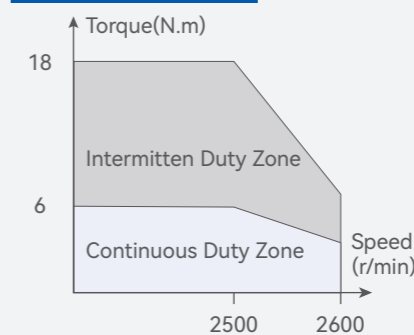

2000W Motor

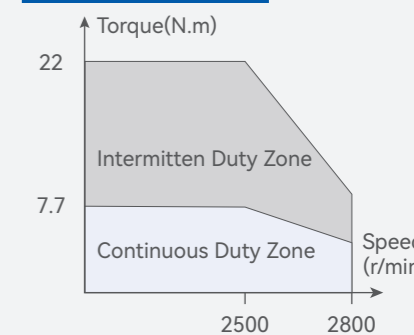

Dimensions

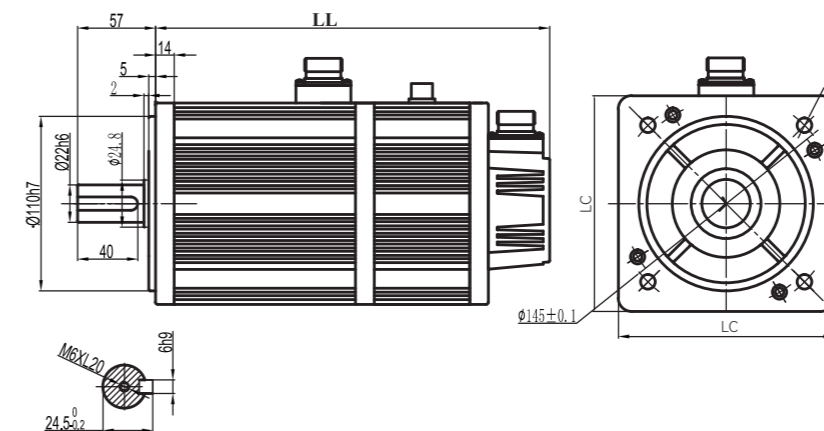

Motor model	LL	LC
ELM2M-1000LB130E-H	223	130
ELM2M-1000LB130F-H	166	
ELM2M-1500LB130E-H	236	131
ELM2M-1500LB130F-H	180	
ELM2M-2000LB130E-H	270	
ELM2M-2000LB130F-H	192	



80mm Frame size & 750W~1000W

Type Name	Frame Size (mm)	Brake	Voltage (VAC)	Power (W)	Speed (rpm)		Torque (Nm)		Current (Arms)		Permissible load to shaft (N)		Encoder	Inertia (kgm ² *10 ⁻⁴)	Weight (kg)	Motor Length (mm)
					Rated	Max	Rated	Max	Rated	Max	Radial	Axial				
ELM2H-0750LA80ET	□ 80	√	400	750	5000	2.39	7.17	2.7	8.8	392	147	23-bit optical encoder	1.65	2.7	121.9	
ELM2H-0750LA80FT		×											1.5	2.12	90.9	
ELM2H-1000LA80ET		√		1000	6000	3.19	9.56	4	12.4				2.15	3.4	134.9	
ELM2H-1000LA80FT		×											2.0	2.8	103.9	

Speed-Torque characteristics

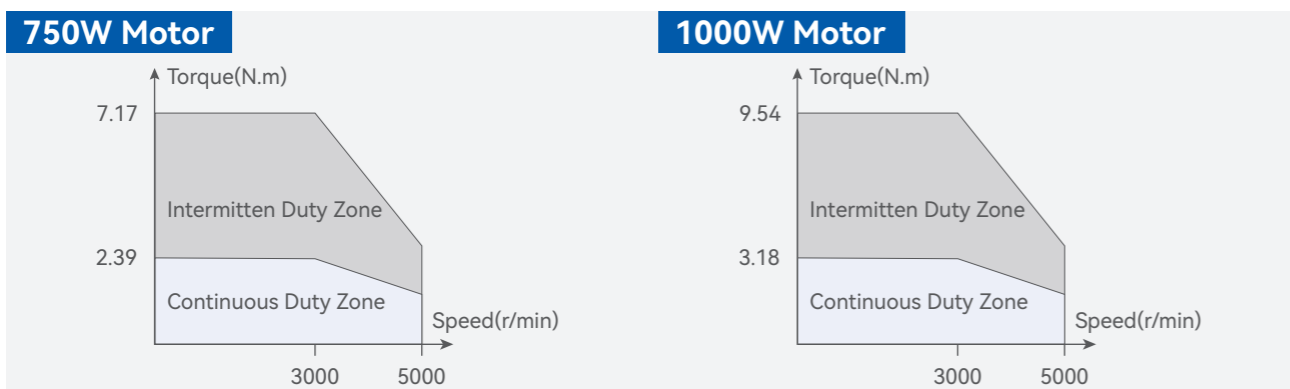

Dimensions

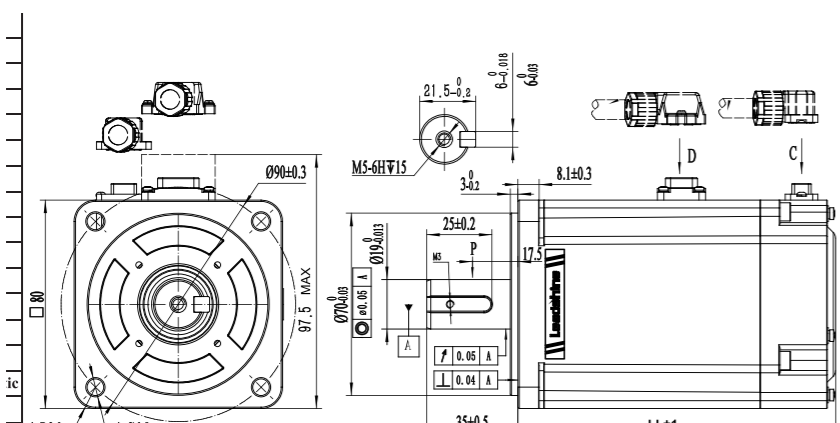

Motor model	LL
ELM2H-0750LA80ET	121.9
ELM2H-0750LA80FT	90.9
ELM2H-1000LA80ET	134.9
ELM2H-1000LA80FT	103.9

100mm Frame size & 1000W~2500W

Type Name	Frame Size (mm)	Brake	Voltage (VAC)	Power (W)	Speed (rpm)		Torque (Nm)		Current (Arms)		Permissible load to shaft (N)		Encoder	Inertia (kgm ² *10 ⁻⁴)	Weight (kg)	Motor Length (mm)
					Rated	Max	Rated	Max	Rated	Max	Radial	Axial				
ELM2L-1000LA100ET-H	□ 100	√	400	1000	6000	3.2	9.6	3.9	11.7	3000	490	23-bit optical encoder	2.63	5.9	194	
ELM2L-1000LA100FT-H		×											2.43	4.6	154	
ELM2L-1500LA100ET-H		√		1500	4.9	14.7	4.5	13.5	3.803				7.1	218		
ELM2L-1500LA100FT-H		×							3.503				5.8	178		
ELM2L-2000LA100ET-H		√		2000	6.36	19.1	6.5	19.5	3.55	7.86	259					
ELM2L-2000LA100FT-H		×							3.07	6.56	219					
ELM2L-2500LA100ET-H		√		2500	7.96	23.9	7.6	22.8	4.16	9.26	285					
ELM2L-2500LA100FT-H		×							3.68	7.96	245					

Speed-Torque characteristics

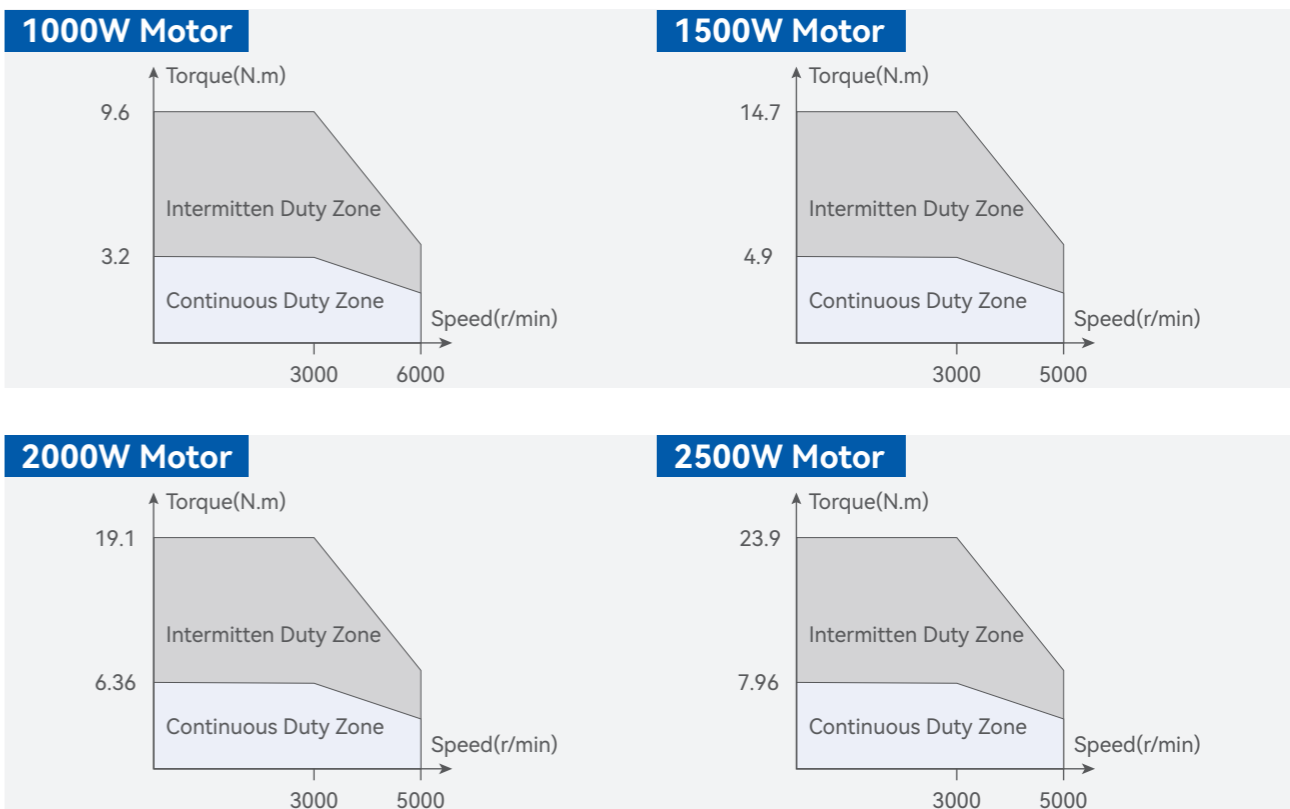

Dimensions

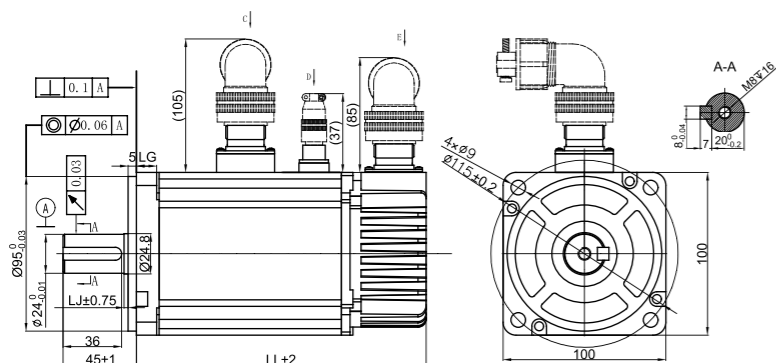

Motor model	LL	LG	LJ
ELM2L-1000LA100ET-H	194	12	2.5
ELM2L-1000LA100FT-H	154		
ELM2L-1500LA100ET-H	218	10	2.0
ELM2L-1500LA100FT-H	178		
ELM2L-2000LA100ET-H	259	10	2.0
ELM2L-2000LA100FT-H	219		
ELM2L-2500LA100ET-H	285	10	2.0
ELM2L-2500LA100FT-H	245		

Speed-Torque characteristics

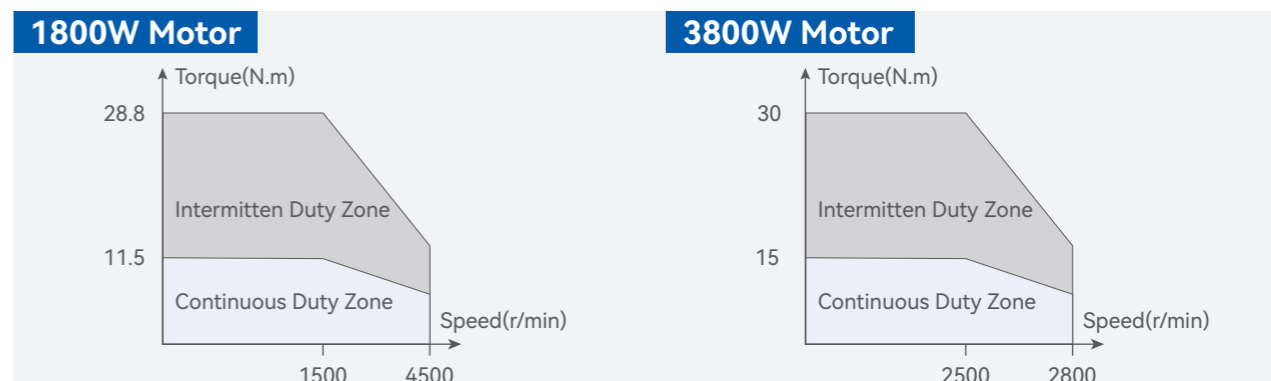
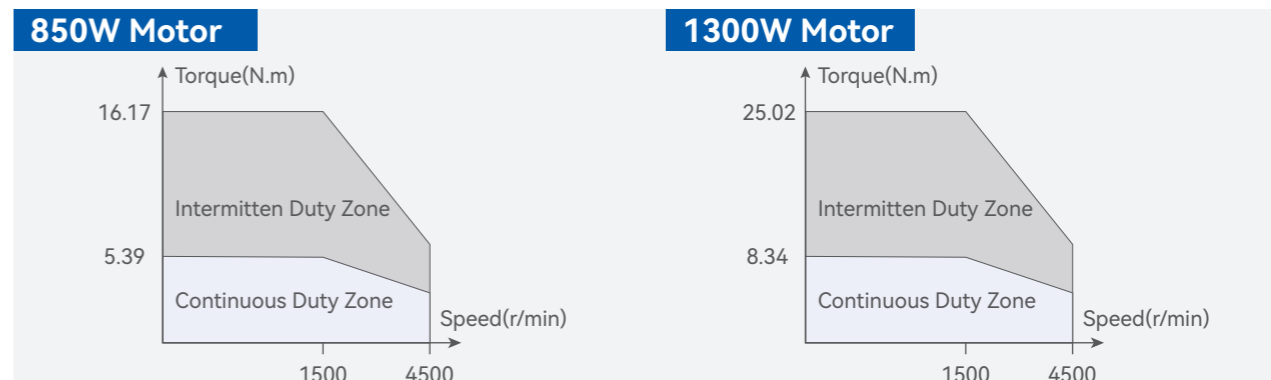

130mm Frame size & 850W~3800W

Type Name	Frame Size (mm)	Brake	Voltage (VAC)	Power (W)	Speed (rpm)		Torque (Nm)		Current (Arms)		Permissible load to shaft (N)		Encoder	Inertia (kgm ² *10 ⁻⁴)	Weight (kg)	Motor Length (mm)
					Rated	Max	Rated	Max	Rated	Max	Radial	Axial				
ELM2H-0850LD130ET-H	□ 130	√	400	850	1500	4500	5.39	15.13	3.5	9.5	98	490	23-bit optical encoder	14.8	6.9	163.7
ELM2H-0850LD130FT-H		×					8.34	23.8	4.6	13.8	343	686		12.5	5.5	136.2
ELM2H-1300LD130ET-H		√		1300	1500	4500	8.34	23.8	4.6	13.8	343	686		21	8.6	181.7
ELM2H-1300LD130FT-H		×					18.7	7.3	154.2							
ELM2H-1800LD130ET-H		√		1800	1500	4500	11.5	32.9	5.6	15.4	392	980		26.1	10.2	199.7
ELM2H-1800LD130FT-H		×					23.8	8.8	172.2							
ELM2M-3800LB130ET-H	□ 131	√	400	3800	2500	2800	15	30	7.4	15	490	196	23-bit optical encoder	27.7	14.8	312
ELM2M-3800LB130FT-H		×					11.7	231								

Dimensions

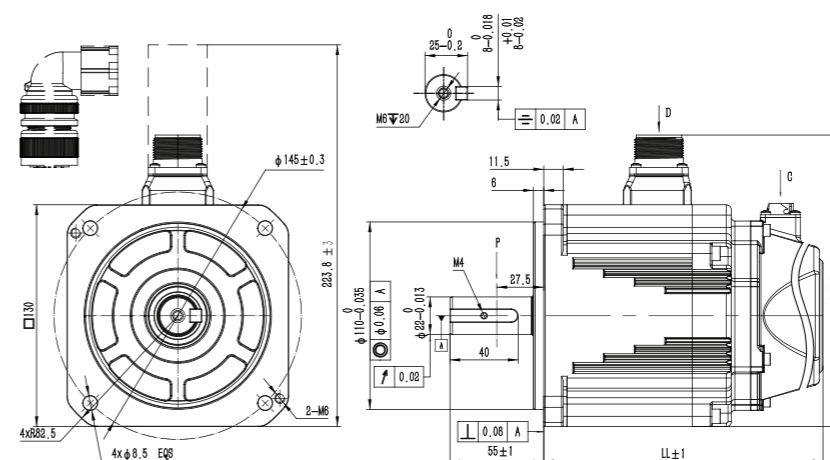

Motor model	LL
ELM2H-0850LD130ET-H	163.7
ELM2H-0850LD130FT-H	136.2
ELM2H-1300LD130ET-H	181.7
ELM2H-1300LD130FT-H	154.2
ELM2H-1800LD130ET-H	199.7
ELM2H-1800LD130FT-H	172.2

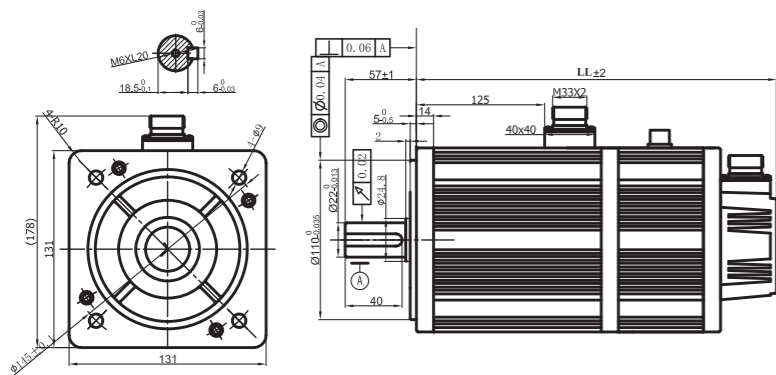

Motor model	LL
ELM2M-3800LB130ET-H	312
ELM2M-3800LB130FT-H	231

5500W Motor

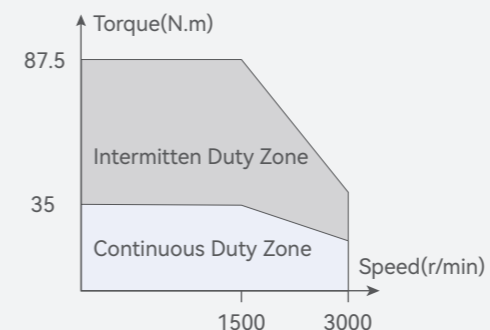

7500W Motor

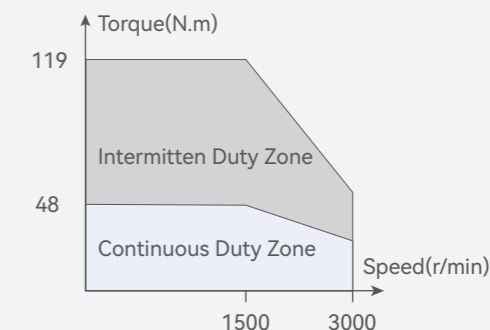

180mm Frame size & 2900W~7500W

Type Name	Frame Size (mm)	Brake	Voltage (VAC)	Power (W)	Speed (rpm)		Torque (Nm)		Current (Arms)		Permissible load to shaft (N)		Encoder	Inertia (kgm ² *10 ⁻⁴)	Weight (kg)	Motor Length (mm)
					Rated	Max	Rated	Max	Rated	Max	Radial	Axial				
ELM2M-2900LD180ET-H	180	√	400	2900	1500	3000	18.6	46.5	11.9	30	1470	490	23-bit optical encoder	40.27	20.5	241
ELM2M-2900LD180FT-H		×														
ELM2M-4400LD180ET-H		√		4400	1500	3000	28.4	71	16.3	41	1764	588		60.41	25.4	271
ELM2M-4400LD180FT-H		×														
ELM2M-5500LD180ET-H		√		5500	1500	3000	35	87.5	20.5	51	1764	588		73.84	30.9	291
ELM2M-5500LD180FT-H		×														
ELM2M-7500LD180ET-H		√		7500	1500	3000	48	119	25.7	64	1764	588		100.7	37	331
ELM2M-7500LD180FT-H		×														

Dimensions

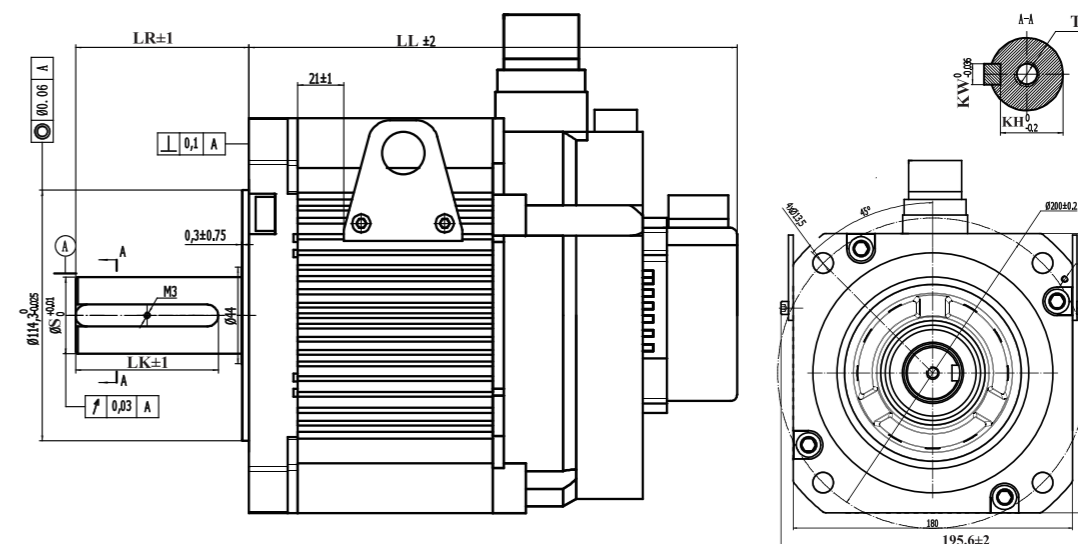

Speed-Torque characteristics

2900W Motor

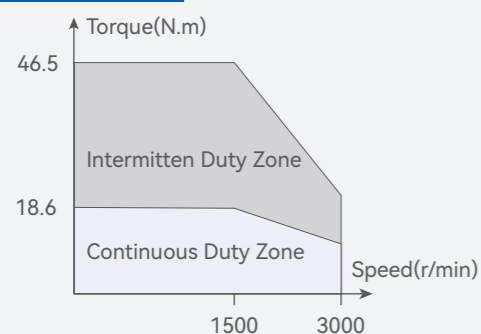

4400W Motor

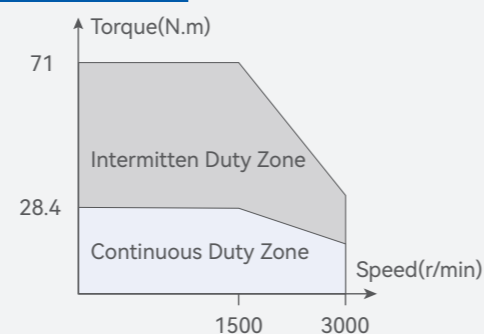

Motor model	LL	LR	LK	S	KW	TP	KH
ELM2M-2900LD180ET-H	241						
ELM2M-2900LD180FT-H	193						
ELM2M-4400LD180ET-H	271						
ELM2M-4400LD180FT-H	223						

Motor model	LL	LR	LK	S	KW	TP	KH
ELM2M-5500LD180ET-H	291						
ELM2M-5500LD180FT-H	243						
ELM2M-7500LD180ET-H	331						
ELM2M-7500LD180FT-H	283						



Cable Selection

The cables which are available for our EL6/EL7/EL8 series AC servo drives and ELM1 & ELM2 AC servo motors are listed in detail in this section including a comprehensive guide on how to match the right cables to the drives and motors.

For our EL6/EL7/EL8 series AC servo drives, a USB Type-C tuning cable is optionally provided to connect the drives to a PC for tuning purposes. Any USB Type-C to Type-A data cable can handle the same task. Ethernet cables are also available for communications between drives and controllers. Safe Torque Off STO cable (2 meters) is included with every purchase of our EL6/EL7/EL8 Series AC servo drives.

Motor power supply cables (including motor brake cables) and encoder cables are matched with our ELM1 and ELM2 series AC servo motors. The cables are matched to the servo motors based on motor series and frame sizes.

Servo Drive Cables

Tuning Cable	EL8-Series EL7-RSP Series EL7-ECN Series EL6-RSP Series	CABLE-TYPEC2M0	
	EL7-ECF series	CABLE-USB1M5	
	EL6-CAN series	CABLE-L6TS1M5	
Communication cable		CABLE-TX*M*-BUS	 <i>*M*represents the length of the cables. For example, 1M5 = 1.5 meters Available length: 0.2M, 0.5M, 1.0M, 1.5M, 3M, 5M, 7M, 10M, 13M</i>
Safe Torque Off STO cable		CABLE-STOH*M*	 <i>*M*represents the length of the cables. For example, 1M5 = 1.5 meters Available length: 0.2M, 1.0M, 1.5M, 2M, 3M, 5M</i>

Motor cable model number

CABLE RZS H 3M0 - 1 1 3 - T - R

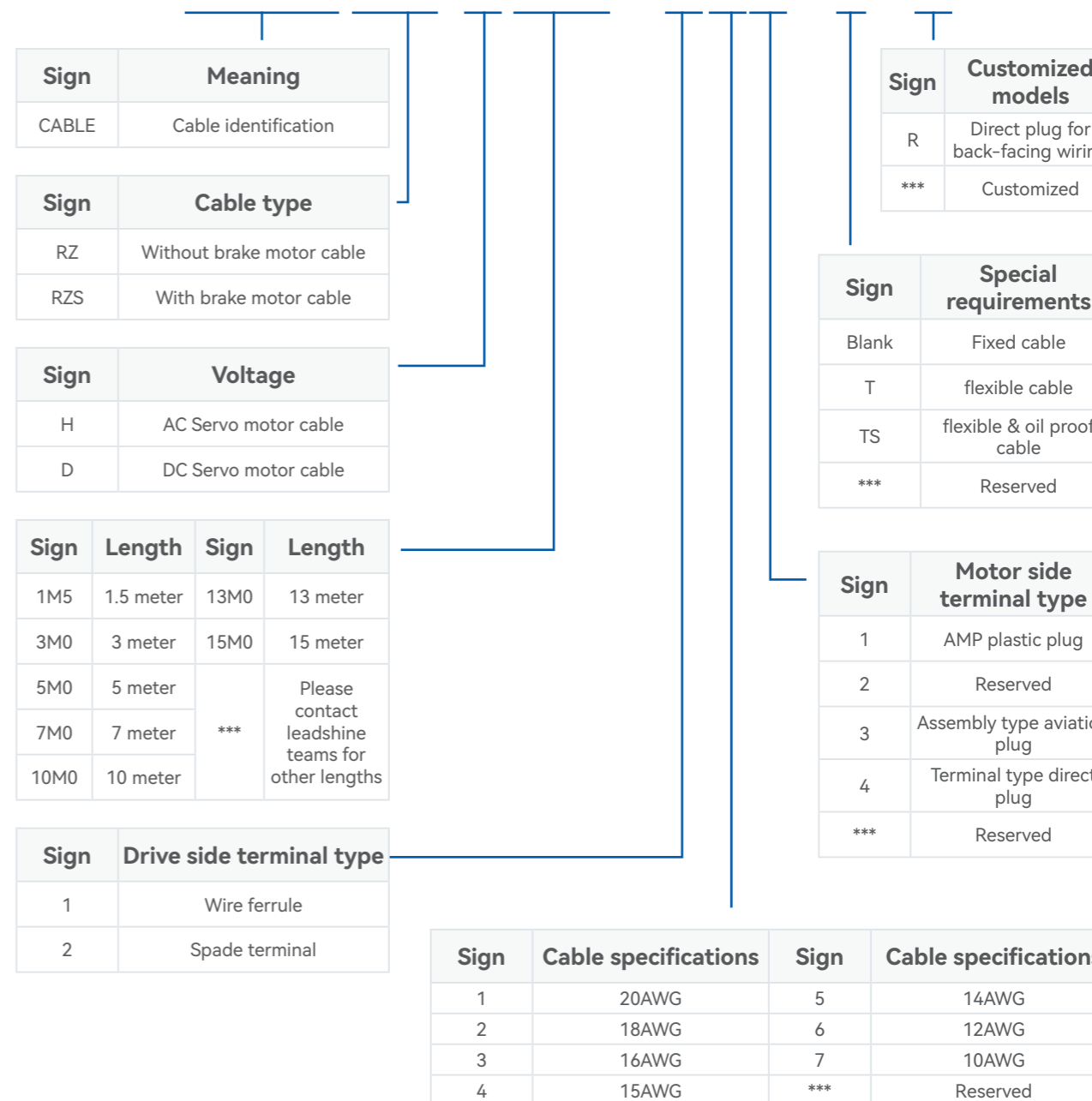

Encoder cable model number

CABLE BMA H 3M0 - 1 1 3 - T - R

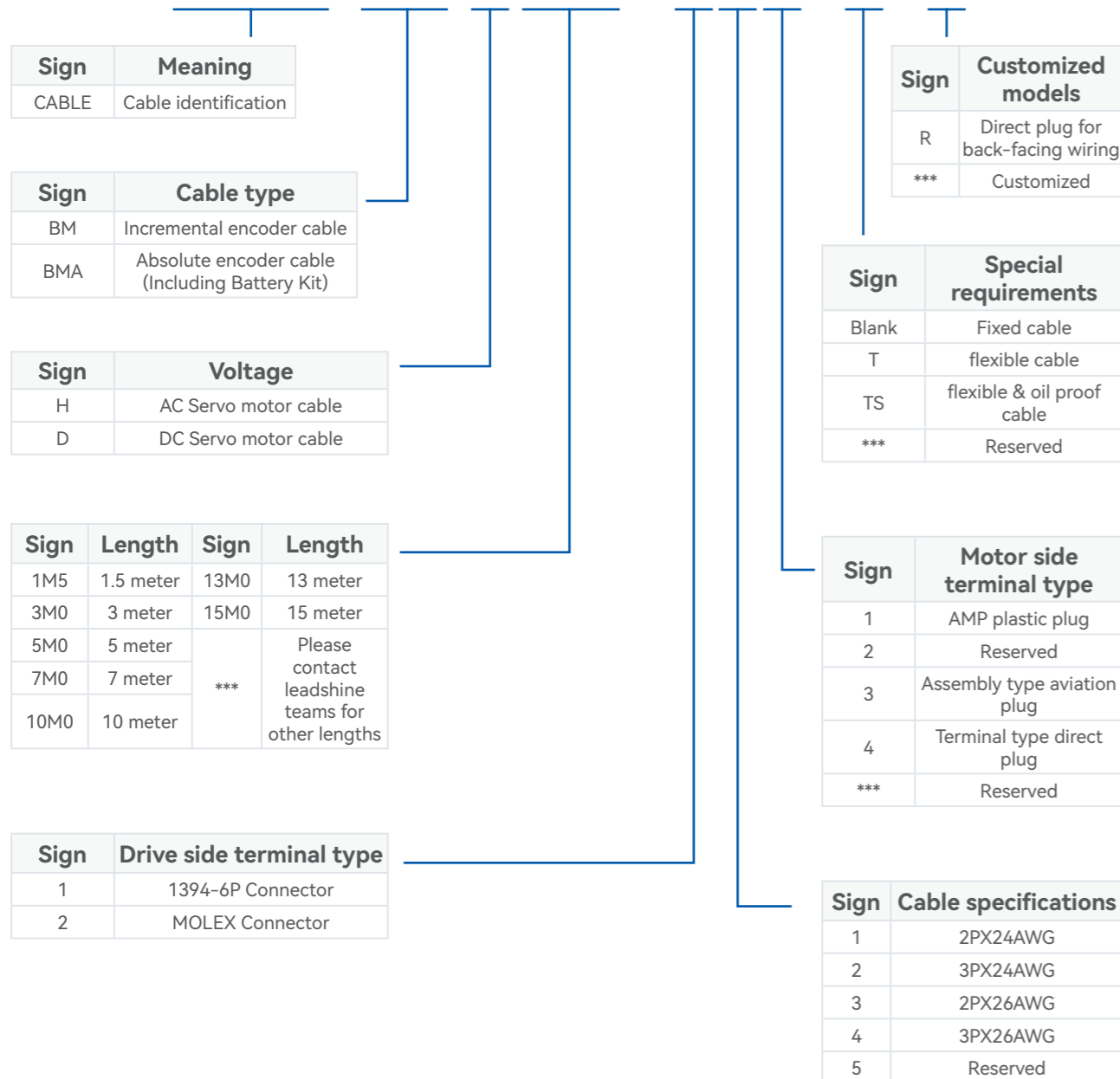

Motor cable model number

CABLE - SC H 3M0 - 1 1 3 - T

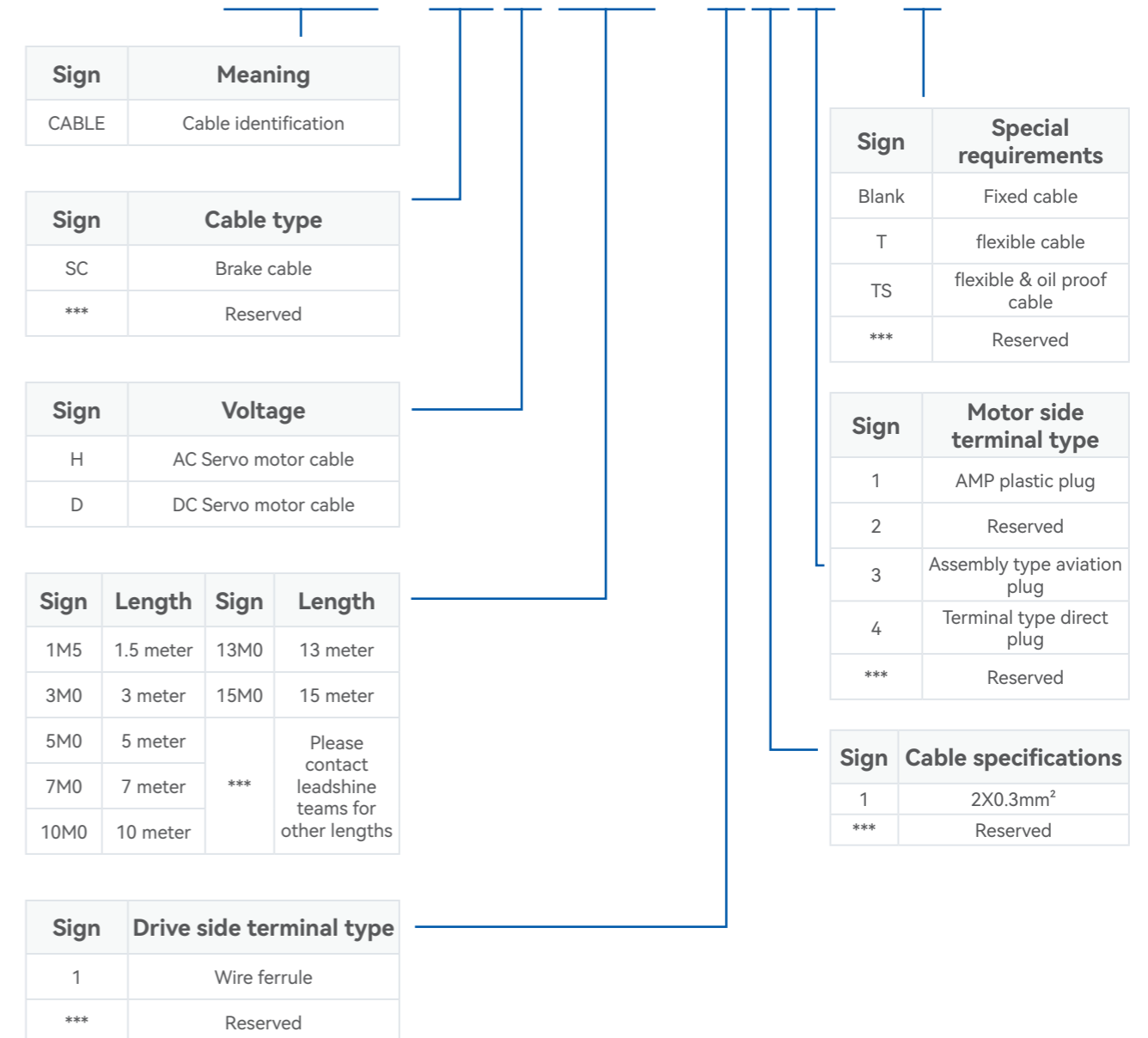

ELM1/ELM2 Series - 40mm/60mm/80mm

- Frame size:40mm/60mm/80mm
- Power rating:50W-1000W



ELM2 Series - 100&130mm

- Frame size:100mm/130mm
- Power rating:1000W/1500W/2000W/2500W/3800W



Cable Type	Diagram	Pin																							
Motor power	<p>CABLE-RZSH*M*-114-TS</p>																								
	<p>CABLE-RZH*M*-114-TS</p>	<table border="1"> <tr><td>1</td><td>Blue</td><td>U</td></tr> <tr><td>2</td><td>Black</td><td>V</td></tr> <tr><td>3</td><td>Red</td><td>W</td></tr> <tr><td>4</td><td>Yellow Green</td><td>PE</td></tr> <tr><td>A*</td><td>Black</td><td>0V</td></tr> <tr><td>B*</td><td>Red</td><td>24V</td></tr> </table> <p>*A&B terminal for motor with brake</p>	1	Blue	U	2	Black	V	3	Red	W	4	Yellow Green	PE	A*	Black	0V	B*	Red	24V					
1	Blue	U																							
2	Black	V																							
3	Red	W																							
4	Yellow Green	PE																							
A*	Black	0V																							
B*	Red	24V																							
Incremental	<p>CABLE-BMH*M*-114-TS</p>																								
Motor encoder	<p>CABLE-BMH*M*-124-TS</p>																								
	<p>ER14505 BOX-G DCH ROHS</p>	<table border="1"> <tr><td>A</td><td>Terminal</td><td>B</td></tr> <tr><td>1</td><td>PE</td><td>-</td></tr> <tr><td>2</td><td>5V</td><td>1</td></tr> <tr><td>3</td><td>0V</td><td>2</td></tr> <tr><td>4</td><td>SD+</td><td>5</td></tr> <tr><td>5</td><td>SD-</td><td>6</td></tr> <tr><td>6*</td><td>BAT+</td><td>-</td></tr> <tr><td>7*</td><td>BAT-</td><td>-</td></tr> </table> <p>*Terminal 6 & 7 is to be connected to battery kit for absolute encoder</p>	A	Terminal	B	1	PE	-	2	5V	1	3	0V	2	4	SD+	5	5	SD-	6	6*	BAT+	-	7*	BAT-
A	Terminal	B																							
1	PE	-																							
2	5V	1																							
3	0V	2																							
4	SD+	5																							
5	SD-	6																							
6*	BAT+	-																							
7*	BAT-	-																							

Cable Type	Diagram	Pin																							
Motor power	<p>CABLE-RZ*M*-H(V2.0)</p>	<table border="1"> <tr><td>1</td><td>Yellow</td><td>PE</td></tr> <tr><td>2</td><td>Red</td><td>U</td></tr> <tr><td>3</td><td>Green</td><td>V</td></tr> <tr><td>4</td><td>Black</td><td>W</td></tr> </table>	1	Yellow	PE	2	Red	U	3	Green	V	4	Black	W											
1	Yellow	PE																							
2	Red	U																							
3	Green	V																							
4	Black	W																							
Motor brake	<p>CABLE-SC*M*-H(V3.0)</p>	<table border="1"> <tr><td>1</td><td>Black</td><td>0V</td></tr> <tr><td>2</td><td>Red</td><td>24V</td></tr> </table>	1	Black	0V	2	Red	24V																	
1	Black	0V																							
2	Red	24V																							
Motor encoder	<p>CABLE-7BM*M*-HZ(V3.0)</p>																								
	<p>CABLE-7BMA*M*-HZ(V3.0)</p>	<table border="1"> <tr><td>A</td><td>Terminal</td><td>B</td></tr> <tr><td>1</td><td>PE</td><td>-</td></tr> <tr><td>2</td><td>5V</td><td>1</td></tr> <tr><td>3</td><td>0V</td><td>2</td></tr> <tr><td>4</td><td>SD+</td><td>5</td></tr> <tr><td>5</td><td>SD-</td><td>6</td></tr> <tr><td>6*</td><td>BAT+</td><td>-</td></tr> <tr><td>7*</td><td>BAT-</td><td>-</td></tr> </table> <p>*Terminal 6 & 7 is to be connected to battery kit for absolute encoder</p>	A	Terminal	B	1	PE	-	2	5V	1	3	0V	2	4	SD+	5	5	SD-	6	6*	BAT+	-	7*	BAT-
A	Terminal	B																							
1	PE	-																							
2	5V	1																							
3	0V	2																							
4	SD+	5																							
5	SD-	6																							
6*	BAT+	-																							
7*	BAT-	-																							

ELM1 Series - 130mm

- Frame size: 130mm
- Power rating: 850W/1300W/1500W/1800W



ELM2 Series - 130mm

- Frame size: 130mm
- Power rating: 850W/1300W/1800W



Cable Type	Diagram	Pin																							
Motor power	<p>CABLE-RZSH*M*-135-TS</p>																								
	<p>CABLE-RZH*M*-135-TS</p>	<table border="1"> <tr><td>A</td><td>Blue</td><td>U</td></tr> <tr><td>B</td><td>Black</td><td>V</td></tr> <tr><td>C</td><td>Red</td><td>W</td></tr> <tr><td>D</td><td>Yellow Green</td><td>PE</td></tr> <tr><td>1*</td><td>Black</td><td>0V</td></tr> <tr><td>2*</td><td>Red</td><td>24V</td></tr> </table> <p>*1&2 terminal for motor with brake</p>	A	Blue	U	B	Black	V	C	Red	W	D	Yellow Green	PE	1*	Black	0V	2*	Red	24V					
A	Blue	U																							
B	Black	V																							
C	Red	W																							
D	Yellow Green	PE																							
1*	Black	0V																							
2*	Red	24V																							
Motor encoder	<p>CABLE-BMH*M*-114-TS</p>																								
	<p>CABLE-BMH*M*-124-TS</p>																								
	<p>ER14505 BOX-G DCH ROHS</p>	<table border="1"> <tr><td>A</td><td>Terminal</td><td>B</td></tr> <tr><td>1</td><td>PE</td><td>-</td></tr> <tr><td>2</td><td>5V</td><td>1</td></tr> <tr><td>3</td><td>0V</td><td>2</td></tr> <tr><td>4</td><td>SD+</td><td>5</td></tr> <tr><td>5</td><td>SD-</td><td>6</td></tr> <tr><td>6*</td><td>BAT+</td><td>-</td></tr> <tr><td>7*</td><td>BAT-</td><td>-</td></tr> </table> <p>*Terminal 6 & 7 is to be connected to battery kit for absolute encoder</p>	A	Terminal	B	1	PE	-	2	5V	1	3	0V	2	4	SD+	5	5	SD-	6	6*	BAT+	-	7*	BAT-
A	Terminal	B																							
1	PE	-																							
2	5V	1																							
3	0V	2																							
4	SD+	5																							
5	SD-	6																							
6*	BAT+	-																							
7*	BAT-	-																							

Cable Type	Diagram	Pin																							
Motor power	<p>CABLE-RZSH*M*-135-TS</p>																								
	<p>CABLE-RZH*M*-135-TS</p>	<table border="1"> <tr><td>A</td><td>Blue</td><td>U</td></tr> <tr><td>B</td><td>Black</td><td>V</td></tr> <tr><td>C</td><td>Red</td><td>W</td></tr> <tr><td>D</td><td>Yellow Green</td><td>PE</td></tr> <tr><td>1*</td><td>Black</td><td>0V</td></tr> <tr><td>2*</td><td>Red</td><td>24V</td></tr> </table> <p>*1&2 terminal for motor with brake</p>	A	Blue	U	B	Black	V	C	Red	W	D	Yellow Green	PE	1*	Black	0V	2*	Red	24V					
A	Blue	U																							
B	Black	V																							
C	Red	W																							
D	Yellow Green	PE																							
1*	Black	0V																							
2*	Red	24V																							
Motor encoder	<p>CABLE-BMH*M*-115-TS</p>																								
	<p>CABLE-BMH*M*-125-TS</p>																								
	<p>ER14505 BOX-G DCH ROHS</p>	<table border="1"> <tr><td>A</td><td>Terminal</td><td>B</td></tr> <tr><td>10</td><td>PE</td><td>-</td></tr> <tr><td>2</td><td>5V</td><td>1</td></tr> <tr><td>3</td><td>0V</td><td>2</td></tr> <tr><td>4</td><td>SD+</td><td>5</td></tr> <tr><td>5</td><td>SD-</td><td>6</td></tr> <tr><td>6*</td><td>BAT+</td><td>-</td></tr> <tr><td>7*</td><td>BAT-</td><td>-</td></tr> </table> <p>*Terminal 6 & 7 is to be connected to battery kit for absolute encoder</p>	A	Terminal	B	10	PE	-	2	5V	1	3	0V	2	4	SD+	5	5	SD-	6	6*	BAT+	-	7*	BAT-
A	Terminal	B																							
10	PE	-																							
2	5V	1																							
3	0V	2																							
4	SD+	5																							
5	SD-	6																							
6*	BAT+	-																							
7*	BAT-	-																							

ELM2M Series - 180mm

- Frame size:180mm
- Power rating:2900W-7500W



Cable Type	Diagram	Pin																							
Motor power	<p>CABLE-RZA*M*-H-180(V1.0)</p>	<table border="1"> <tr><td>A</td><td>Blue</td><td>U</td></tr> <tr><td>B</td><td>Black</td><td>V</td></tr> <tr><td>C</td><td>Red</td><td>W</td></tr> <tr><td>D</td><td>Yellow Green</td><td>PE</td></tr> </table>	A	Blue	U	B	Black	V	C	Red	W	D	Yellow Green	PE											
		A	Blue	U																					
B	Black	V																							
C	Red	W																							
D	Yellow Green	PE																							
4400W-7500W	<p>CABLE-RZB*M*-H-180(V1.0)</p>	<table border="1"> <tr><td>A</td><td>White</td><td>U</td></tr> <tr><td>B</td><td>Black</td><td>V</td></tr> <tr><td>C</td><td>Red</td><td>W</td></tr> <tr><td>D</td><td>Yellow Green</td><td>PE</td></tr> </table>	A	White	U	B	Black	V	C	Red	W	D	Yellow Green	PE											
A	White	U																							
B	Black	V																							
C	Red	W																							
D	Yellow Green	PE																							
Motor brake	<p>CABLE-SC-H-180(V1.0)</p>	<table border="1"> <tr><td>1</td><td>Black</td><td>0V</td></tr> <tr><td>2</td><td>Red</td><td>24V</td></tr> </table>	1	Black	0V	2	Red	24V																	
1	Black	0V																							
2	Red	24V																							
Motor encoder	<p>CABLE-7BM-HZ-180(V1.0)</p>																								
		<p>CABLE-7BMA-HZ-180(V1.0)</p>	<table border="1"> <tr><td>A</td><td>Terminal</td><td>B</td></tr> <tr><td>10</td><td>PE</td><td>-</td></tr> <tr><td>2</td><td>5V</td><td>1</td></tr> <tr><td>3</td><td>0V</td><td>2</td></tr> <tr><td>4</td><td>SD+</td><td>5</td></tr> <tr><td>5</td><td>SD-</td><td>6</td></tr> <tr><td>6*</td><td>BAT+</td><td>-</td></tr> <tr><td>7*</td><td>BAT-</td><td>-</td></tr> </table> <p>*Terminal 6 & 7 is to be connected to battery kit for absolute encoder</p>	A	Terminal	B	10	PE	-	2	5V	1	3	0V	2	4	SD+	5	5	SD-	6	6*	BAT+	-	7*
A	Terminal	B																							
10	PE	-																							
2	5V	1																							
3	0V	2																							
4	SD+	5																							
5	SD-	6																							
6*	BAT+	-																							
7*	BAT-	-																							

Typical configuration examples

EL8 Series

Frame Size (mm)	Rated Power (W)	Motor Model	Matching Drive	Motor Length (mm)	Rated Torque (Nm)	Rated/Max Speed(rpm)	Rated Currnt (Arms)	Inertia (kgm2*10 ⁻⁴)	Motor Cable	Encoder cable	Brake Cable	Turning Cable
40	50W (220V)	ELM2H-0050LA40F	EL8-RS400F EL8-EC400F	56.7	0.16	3000/5000	0.93	0.0355	CABLE-RZH*M*-114-TS- (R) [without brake] CABLE-RZSH*M*-114-TS- (R) [with brake] (Add "R" after the model for back facing motor wiring)	CABLE-BMH*M*-114-TS-(R) [Incremental] CABLE-BMH*M*-124-TS-(R) [Absolute] +ER14505 BOX-G (Battery Kit) (Add "R" after the model for back facing motor wiring)		CABLE-TYPEC2M0
		ELM2H-0050LA40E		84				0.0456				
	100W (220V)	ELM2H-0100LA40F		67.7	0.32	3000/5000	0.92	0.0620				
		ELM2H-0100LA40E		95				0.0721				
60	200W (220V)	ELM2H-0200LA60F	EL8-RS750F EL8-EC750F	71.6	0.64	3000/5000	1.5	0.29				
		ELM2H-0200LA60E		100.9				0.31				
	400W (220V)	ELM2H-0400LA60F		88.8	1.27	3000/5000	2.1	0.56				
		ELM2H-0400LA60E		118.1				0.58				
80	750W (220V)	ELM2H-0750LA80F	EL8-RS1000F EL8-EC1000F	90.9	2.39	3000/5000	4.1	1.5				
		ELM2H-0750LA80E		121.9				1.65				
130	1000W (220V)	ELM2H-1000LA80F	EL8-RS1500F EL8-EC1500F	103.9	3.18	3000/5000	5.7	2.03	CABLE-RZH*M*-135-TS [without brake] CABLE-RZSH*M*-135-TS [with brake]	CABLE-BMH*M*-115-TS [Incremental] CABLE-BMH*M*-125-TS [Absolute] +ER14505 BOX-G (Battery Kit)		
		ELM2H-1000LA80E		134.9				2.13				
	850W (220V)	ELM2H-0850LD130F-H		126	5.39	1500/4500	-	12.5				
		ELM2H-0850LD130E-H		153.5				14.8				
1800W (220V)	1300W (220V)	ELM2H-1300LD130F-H	EL8-RS2000F EL8-EC2000F	144	8.43	1500/4500	-	18.7				
		ELM2H-1300LD130E-H		171.5				21				
		ELM2H-1800LD130F-H		162	11.5	1500/4500	-	23.8				
		ELM2H-1800LD130E-H		189.5				26.1				

EL7 Series

Frame Size (mm)	Rated Power (W)	Motor Model	Matching Drive	Motor Length (mm)	Rated Torque (Nm)	Rated/Max Speed(rpm)	Inertia (kgm ² *10 ⁻⁴)	Motor Cable	Encoder cable	Brake Cable
40	50W (220V)	ELM2H-0050LA40F	EL7-RS400P EL7-EC400F EL7-EC400N EL7-PN400F	56.7	0.16	3000/5000	0.036	CABLE-RZH*M*-114-TS- (R) 【without brake】 CABLE-RZSH*M*-114-TS- (R) 【with brake】 (Add "R" after the model for back facing motor wiring)	CABLE-BMH*M*-114-TS- (R) 【Incremental】 CABLE-BMH*M*-124-TS- (R) 【Absolute】 +ER14505 BOX-G (Battery Kit) (Add "R" after the model for back facing motor wiring)	If you need brake cable, please select power cable with brake in the power cable column.
		ELM2H-0050LA40E		84			0.046			
	100W (220V)	ELM2H-0100LA40F		67.7	0.32	3000/5000	0.062			
		ELM2H-0100LA40E		95			0.072			
60	200W (220V)	ELM2H-0200LA60F	EL7-RS750P EL7-EC750F EL7-EC750N EL7-PN750F	71.6	0.64	3000/5000	0.28	CABLE-RZH*M*-114-TS- (R) 【without brake】 CABLE-RZSH*M*-114-TS- (R) 【with brake】 (Add "R" after the model for back facing motor wiring)	CABLE-BMH*M*-114-TS- (R) 【Incremental】 CABLE-BMH*M*-124-TS- (R) 【Absolute】 +ER14505 BOX-G (Battery Kit) (Add "R" after the model for back facing motor wiring)	If you need brake cable, please select power cable with brake in the power cable column.
		ELM2H-0200LA60E		101.1			0.3			
	400W (220V)	ELM2H-0400LA60F		88.8	1.27	3000/5000	0.6			
		ELM2H-0400LA60E		118.1			0.62			
80	750W (220V)	ELM2H-0750LA80F	EL7-RS1000P EL7-EC1000F EL7-EC1000N EL7-PN1000F	90.9	2.39	3000/5000	1.8	CABLE-RZH*M*-114-TS- (R) 【without brake】 CABLE-RZSH*M*-114-TS- (R) 【with brake】 (Add "R" after the model for back facing motor wiring)	CABLE-BMH*M*-114-TS- (R) 【Incremental】 CABLE-BMH*M*-124-TS- (R) 【Absolute】 +ER14505 BOX-G (Battery Kit) (Add "R" after the model for back facing motor wiring)	If you need brake cable, please select power cable with brake in the power cable column.
		ELM2H-0750LA80E		121.9			1.95			
	1000W (220V)	ELM2H-1000LA80F		103.9	3.2	3000/5000	2			
		ELM2H-1000LA80E		134.9			2.15			
	750W (380V)	ELM2H-0750LA80FT		90.9	2.39	3000/5000	2.12			
		ELM2H-0750LA80ET		121.9			2.7			
100	1000W (220V)	ELM2L-1000LA100F-H	EL7-RS1000P EL7-EC1000F EL7-EC1000N EL7-PN1000F	154	3.2	3000/6000	2.43	CABLE-RZ*M*-H (V1.1) 【Fixed cable】 CABLE-RZ*M*-H (V2.0) 【Flexible cable】	CABLE-7BM*M*-HZ (V3.0) 【Incremental】 CABLE-7BMA*M*-HZ (V3.0) 【Absolute】	CABLE-SC*M*-H (V3.0)
		ELM2L-1000LA100E-H		194			2.63			
	1500W (220V)	ELM2L-1500LA100F-H		178	4.9	3000/5000	3.503			
		ELM2L-1500LA100E-H		218			3.803			

Frame Size (mm)	Rated Power (W)	Motor Model	Matching Drive	Motor Length (mm)	Rated Torque (Nm)	Rated/Max Speed(rpm)	Inertia (kgm ² *10 ⁻⁴)	Motor Cable	Encoder cable	Brake Cable
130	850W (220V)	ELM2H-0850LD130F-H	EL7-RS1000P EL7-EC1000F EL7-EC1000N EL7-PN1000F	126	5.39	1500/4500	12.5	CABLE-RZH*M*-135-TS 【without brake】 CABLE-RZSH*M*-135-TS 【with brake】	CABLE-BMH*M*-115-TS 【Incremental】 CABLE-BMH*M*-125-TS 【Absolute】 +ER14505 BOX-G (Battery Kit)	If you need brake cable, please select power cable with brake in the power cable column.
		ELM2H-0850LD130E-H		153.5			8.34			
	1300W (220V)	ELM2H-1300LD130F-H	EL7-RS1500P EL7-EC1500N EL7-PN1500F	144	8.34	1500/4500	18.7			
		ELM2H-1300LD130E-H		171.5			21			
	1800W (220V)	ELM2H-1800LD130F-H	EL7-RS2000P EL7-EC2000N EL7-PN2000F	162	11.5	1500/3000	23.8			
		ELM2H-1800LD130E-H		189.5			26.1			
	850W (400V)	ELM2H-0850LD130FT-H	EL7-RS1000PT EL7-EC1000FT EL7-EC1000NT EL7-PN1000FT	126	5.39	1500/4500	12.5			
		ELM2H-0850LD130ET-H		153.5			14.8			
	1300W (400V)	ELM2H-1300LD130FT-H	EL7-RS1500PT EL7-EC1500FT EL7-EC1500NT EL7-PN1500FT	144	8.34	1500/4500	18.7			
		ELM2H-1300LD130ET-H		171.5			21			
	1800W (400V)	ELM2H-1800LD130FT-H	EL7-RS2000PT EL7-EC2000FT EL7-EC2000NT EL7-PN2000FT	162	11.5	1500/3000	23.8			
		ELM2H-1800LD130ET-H		189.5			26.1			
180	2900W (400V)	ELM2M-2900LD180FT-H	EL7-RS3000PT EL7-EC3000FT EL7-EC3000NT EL7-PN3000FT	193	18.6	1500/3000	39.78	CABLE-RZA-H-180 (V1.0)	CABLE-7BM*M*-HZ-180 (V1.0) 【Incremental】 CABLE-7BMA*M*-HZ-180 (V1.0) 【Absolute】	CABLE-SC*M*-H-180 (V1.0)
		ELM2M-2900LD180ET-H		241			40.27			
	4400W (400V)	ELM2M-4400LD180FT-H	EL7-RS4400PT EL7-EC4400FT EL7-EC4400NT EL7-PN4400FT	223	28.4		59.67			
		ELM2M-4400LD180ET-H		271			60.41			
	5500W (400V)	ELM2M-5500LD180FT-H	EL7-RS5500PT EL7-EC5500FT EL7-EC5500NT EL7-PN5500FT	243	35		72.93			
		ELM2M-5500LD180ET-H		291			73.84			
7500W (400V)	ELM2M-7500LD180FT-H	EL7-RS7500PT EL7-EC7500FT EL7-EC7500NT EL7-PN7500FT	283	48	99.45					
	ELM2M-7500LD180ET-H		331		100.7					

EL6 Series

Frame Size (mm)	Rated Power (W)	Motor Model	Matching Drive	Motor Length (mm)	Rated Torque (Nm)	Rated/Max Speed(rpm)	Inertia (kgm ² *10 ⁻⁴)	Motor Cable	Encoder cable	Brake Cable
40	50W (220V)	ELM2H-0050LA40F	EL6-RS400P EL6-CAN400Z	56.7	0.16	3000/5000	0.036	CABLE-RZH*M*-114-TS- (R) 【without brake】 CABLE-RZSH*M*-114-TS- (R) 【with brake】 (Add "R" after the model for back facing motor wiring)	CABLE-BMH*M*-114-TS 【Incremental】 CABLE-BMH*M*-124-TS- (R) 【Absolute】 +ER14505 BOX-G (Battery Kit) (Add "R" after the model for back facing motor wiring)	If you need brake cable, please select power cable with brake in the power cable column.
		ELM2H-0050LA40E		84						
	100W (220V)	ELM2H-0100LA40F		67.7	0.32	3000/5000	0.062			
		ELM2H-0100LA40E		95						
60	200W (220V)	ELM2H-0200LA60F	EL6-RS750P EL6-CAN750Z	71.6	0.64	3000/5000	0.28	CABLE-RZH*M*-114-TS- (R) 【without brake】 CABLE-RZSH*M*-114-TS- (R) 【with brake】 (Add "R" after the model for back facing motor wiring)	CABLE-BMH*M*-114-TS 【Incremental】 CABLE-BMH*M*-124-TS- (R) 【Absolute】 +ER14505 BOX-G (Battery Kit) (Add "R" after the model for back facing motor wiring)	If you need brake cable, please select power cable with brake in the power cable column.
		ELM2H-0200LA60E		101.1						
	400W (220V)	ELM2H-0400LA60F		88.8	1.27	3000/5000	0.6			
		ELM2H-0400LA60E		118.1						
80	750W (220V)	ELM2H-0750LA80F	EL6-RS1000P EL6-CAN1000Z	90.9	4.9	3000/5000	1.8	CABLE-RZH*M*-114-TS- (R) 【without brake】 CABLE-RZSH*M*-114-TS- (R) 【with brake】 (Add "R" after the model for back facing motor wiring)	CABLE-BMH*M*-114-TS 【Incremental】 CABLE-BMH*M*-124-TS- (R) 【Absolute】 +ER14505 BOX-G (Battery Kit) (Add "R" after the model for back facing motor wiring)	If you need brake cable, please select power cable with brake in the power cable column.
		ELM2H-0750LA80E		121.9						
	1000W (220V)	ELM2H-1000LA80F		103.9	8.34	3000/5000	2			
		ELM2H-1000LA80E		134.9						
100	1000W (220V)	ELM2L-1000LA100F-H	EL6-RS1000P EL6-CAN1000Z	154	11.5	3000/6000	2.43	CABLE-RZ*M*-H (V1.1) 【Fixed cable】 CABLE-RZ*M*-H (V2.0) 【Flexible cable】	CABLE-7BM*M*-HZ (V3.0) 【Incremental】 CABLE-7BMA*M*-HZ (V3.0) 【Absolute】	CABLE-SC*M*-H (V3.0)
		ELM2L-1000LA100E-H		194						
130	850W (220V)	ELM2H-0850LD130F-H	EL6-RS1000P EL6-CAN1000Z	126	8.34	1500/4500	12.5	CABLE-RZH*M*-135-TS 【without brake】 CABLE-RZSH*M*-135-TS 【with brake】	CABLE-BMH*M*-114-TS 【Incremental】 CABLE-BMH*M*-124-TS- (R) 【Absolute】 +ER14505 BOX-G (Battery Kit) (Add "R" after the model for back facing motor wiring)	If you need brake cable, please select power cable with brake in the power cable column.
		ELM2H-0850LD130E-H		153.5						



Headquarters
China Leadshine Technology Co., Ltd.

☎ +86 755 26411692 📠 +86 755 26402718
🌐 www.leadshine.com
✉ sales@leadshine.com (Sales)
 tech@leadshine.com (Technical Support)
📍 15-20/F, Block B, Nanshan i-Valley, Shuguang Community,
 Xili Town, Nanshan District, Shenzhen 518055, China

North America Office
Leadshine America, Inc.

☎ 1-949-608-7270 📠 1-949-638-7298
🌐 www.leadshineusa.com
✉ sales@leadshineusa.com (Sales)
 support@leadshineusa.com (Technical Support)
📍 26050 Towne Centre Dr. Foothill Ranch, CA 92610 USA

