

Global Sales & Service Network

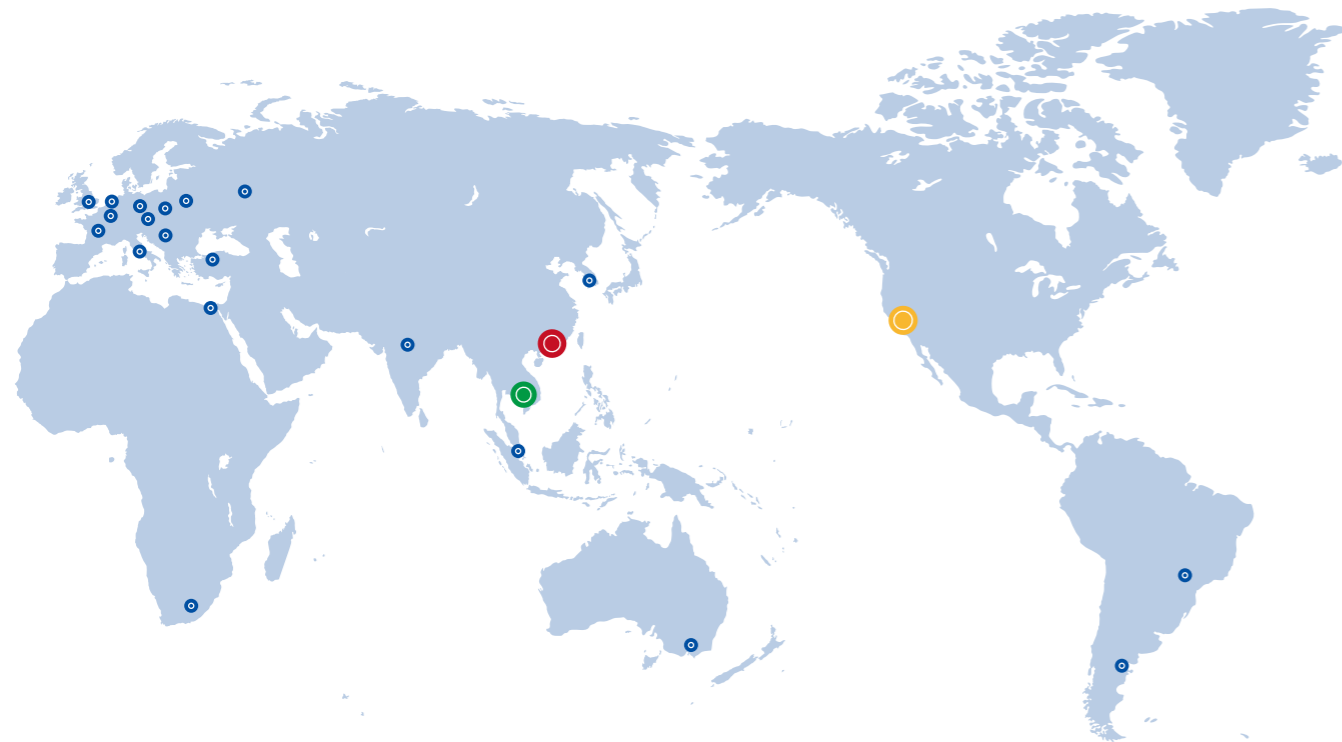

📍 Headquarters
Leadshine Technology Co., Ltd.

📍 North America Office
Leadshine America, Inc.

📍 Vietnam Representative Office

Headquarters China Leadshine Technology Co., Ltd.

☎ +86 755 26411692

🖨 +86 755 26402718

🌐 www.leadshine.com

✉ sales@leadshine.com (Sales)

✉ tech@leadshine.com (Technical Support)

📍 15-20/F, Block B, Nanshan i-Valley, Shuguang Community,
Xili Town, Nanshan District, Shenzhen 518055, China

North America Office Leadshine America, Inc.

☎ 1-949-608-7270

🖨 1-949-638-7298

🌐 www.leadshineusa.com

✉ sales@leadshineusa.com (Sales)

✉ support@leadshineusa.com (Technical Support)

📍 26050 Towne Centre Dr. Foothill Ranch, CA 92610 USA

D230525



STEPPER PRODUCTS

- Stepper Motors and Drives
- Closed Loop Stepper Motors and Drives
- Integrated Stepper Motors
- Power Supplies and Gearboxes



EtherNet/IP

Modbus

EtherCAT

CANopen

Company Profile

- **Founded in 1997**
- **Public Listed Company in China (002979.SZ)**
- **Dedication in Motion Control**
Stepper/Servo systems, Motion Controllers, PLC Control systems, I/O Modules, Encoders
- **A leading supplier of motion control products and solutions in the world**
- **Customer Oriented, Technology Oriented, Forever Improving, Sharing of Success**



Leadshine Shenzhen Headquarter



Shanghai Intelligent Industry Park



Production base in Shenzhen

R&D

Led by Dr. Li, a PhD majored in robotics & servo controls from MIT, Leadshine has one of the strongest R&D teams in the motion control industry.

The team consists of more than 100 R&D engineers and all of them are highly educated with most of them carry PhD & Master degrees in controls, electrical & electronics engineering, mechanical engineering, mechatronics, computer engineering, and computer science.

Their strong background and experience allow Leadshine capable of designing superior quality products based the latest technology in the most efficient way.

Product Quality

Leadshine operates manufacturing facilities which are superiorly equipped, professionally staffed, and ISO-9001 certified.

That allows Leadshine to provide highly reliable quality motion control products OEM clients in the shortest time.

Leadshine's products have proven records of being successfully adopted in thousands of applications such as CNC routers, mills, plasmas, lathes, laser cutters/engravers/markers, inkjet printers, plotters, electronics equipments, medical equipments, semiconductor assembly & inspection machines, electronics machines, packaging equipments, textile machines, robotics, pick-and-place devices, etc. In most cases, Leadshine's standard "off-the-shelf" products are able to satisfy the motion control needs for most applications.

For many OEM applications with special requirements, Leadshine also offers customized products with optimized performance.

Support and Service

Leadshine believes the key to be a successful motion product supplier is the commitment to fully understanding our customer's applications and working closely with our OEM clients.

In many cases, Leadshine engineers can participate in the whole process of client product development, including initial application evaluation, product selection, design help & suggestion.

Our expertise and experience allow us to help OEM clients to produce competitive high quality machines in their industries.

Contents



Overview

Company Profile	01
Typical Industry Applications	03
Product Overview	04
Product Quick Selection	07

Stepper Motors and Drives

Part Numbers	18
Fieldbus Stepper Drives	
2EM3EIP Dual-axis Series 	19
2EM3E Dual-axis Series 	20
EM3E Series	22
EM2RS Series	21
Pulse Control Stepper Drives	
EM-S/DM-E Series	23
5-phase Stepper Drives 	28
CM Series Stepper Motors	29

Closed Loop Stepper Motors and Drives

Part Numbers	41
Fieldbus Closed Loop Stepper Drives	
2CS3EIP Dual-axis Series 	42
2CS3E Dual-axis Series 	43
CS3E Series	44
CS2RS Series	45
Pulse Control Closed Loop Stepper Drives	
CS1/CS Series	46
CS-M Series Closed Loop Stepper Motors	48

Integrated Stepper Motors

Integrated Stepper Motors	56
---------------------------	----

Other Products

LSP Series Power Supplies	60
PLF Series Gearboxes	61

Typical Industry Applications



Electronic manufacturing equipment

- Dispensing machine
- Screw locking machine
- SMT
- Wire stripping machine
- Lithium battery equipment



Laser machine industry

- Laser marking machine
- Laser cutting machine
- Jade carving machine
- Wood carving machine



Special machine tool industry

- CNC machine
- Die stamping machine



Packaging

- Filling machine
- Pillow packaging machine
- Labeling machine
- Vertical packaging machine

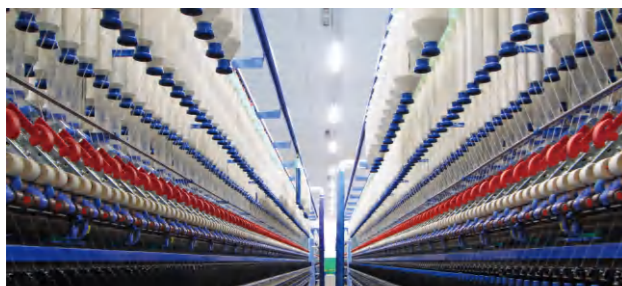

Textile and garment

- Computer cutting plotter
- Template cutting machine
- Garment proofing machine
- Pattern cutting machine
- Vertical jet cutting machine



Medical and healthCARE industry

- Biochemical analyzer
- Peristaltic pump
- Mask machine
- Blood sample analyzer
- Urine analyzer

Product Overview

Fieldbus Stepper Drives



2EM3EIP Series



2EM3E Series



EM3E Series



EM2RS Series



- Power Voltage:**
- 20-50VDC, 20-80VDC
 - 30-110VDC or 20-80VAC
- Command Source:**
- EtherCAT, EtherNet/IP, Modbus RTU

- Inputs and Outputs:**
- EM3E-522E/556E/870E: 5 DI, 2 DO
 - EM3E-A882: 7 DI, 6 DO
 - 2EM3E Series: Dual-axis, 4 DI, 2 DO
 - 2EM3EIP Series: Dual-axis, 4 DI, 2 DO

Pulse Control Stepper Drives



EM Series



DM Series

Pulse & Direction

- Power Voltage:**
- 12-40VDC, 20-50VDC, 20-80VDC
 - 30-110VDC or 20-80VAC, 110VAC±10%, 220VAC±10%
- Command Source:**
- EM-S: Pulse&Direction, CW&CCW
 - DM-E: Pulse&Direction

- Inputs and Outputs:**
- DM332E/322E: 3 DI
 - DM542E/556E: 3 DI, 1 DO
 - DMA860E: 3 DI, 2 DO
 - DM1182/DM2282: 3 DI
 - 3DM580S/883/2283: 3 DI
 - EM-S: 3 DI, 1 DO

5-phase Stepper Drives (Coming Soon)



5-phase Stepper Drives



Pulse & Direction

Standard Stepper Motors



CM Series

- Frame Size:**
- From NEMA 08(20mm) to NEMA 51(130mm)
 - 2-phase: 20mm, 28mm, 35mm, 42mm, 57mm, 60mm, 86mm, 110mm, 130mm
 - 3-phase: 57mm, 86mm, 110mm
- Options:**
- Dual shaft
 - Encoder
 - Brake
 - IP65 waterproof
 - Gearbox

Fieldbus Closed Loop Stepper Drives



- Power Voltage:**
- 20-50VDC
 - 30-110VDC or 20-80VAC
- Command Source:**
- EtherCAT, EtherNet/IP, Modbus RTU
- Inputs and Outputs:**
- CS3E-D503/507/1008: 7 DI / 7 DO
 - CS2RS-D503/507/1008: 7 DI, 3 DO
 - 2CS3E series: Dual-axis, 4 DI, 2 DO
 - 2CS3EIP series: Dual-axis, 4 DI, 2 DO

Integrated Stepper Motors



- Open loop: iEM Series
Closed loop: iCS Series
- iEM-RS Series
iCS-RS Series

Pulse & Direction Modbus

- Power Voltage:**
- 20-36VDC
 - 20-50VDC
- Command Source:**
- iEM/iCS: Pulse&Direction
 - iEM-RS/iCS-RS: Modbus RS485
- Inputs and Outputs:**
- 3 DI, 1 DO

Pulse Control Closed Loop Stepper Drives

Pulse & Direction



- Power Voltage:**
- 20-50VDC
 - 20-72VDC
 - 20-80VAC or 30-110VDC
- Command Source:**
- Pulse&Direction, CW&CCW
- Inputs and Outputs:**
- CS1-D507S: 4 DI, 3 DO encoder outputs
 - CS1-D728S: 4 DI, 3 DO
 - CS-D507E: 3 DI, 2 DO
 - CS-D1008E: 3 DI, 2 DO

Power Supplies

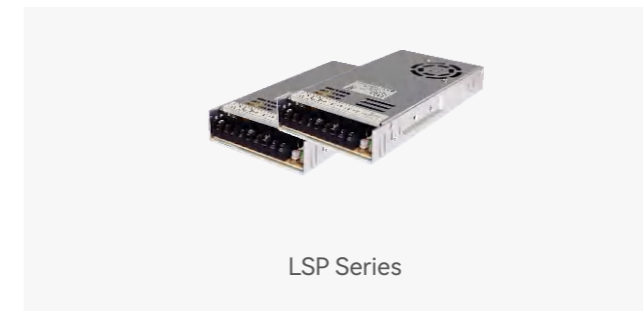

LSP Series

- Power Voltage:**
- 220VAC±10% or 110VAC±10% input
 - 260W: 24VDC output
 - 360W: 24VDC/36VDC/48VDC output
 - 400W: 60VDC output

Closed Loop Stepper Motors



CS-M Series & ES2-MH Series

- Frame Size and Encoder:**
- 20mm: 1000 line
 - 28mm: 1000 line
 - 42mm: 1000/5000 line
 - 57mm: 1000/5000 line
 - 60mm: 1000/5000 line
 - 86mm: 1000/5000 line
 - 110mm: 1000/5000 line
- Options:**
- Brake
 - IP65 waterproof

Gearboxes



PLF Series

- Gearboxes:**
- 60mm: 3:1, 5:1, 7:1, 10:1
 - 90mm: 3:1, 5:1, 7:1, 10:1
 - NEMA 23 and 34
 - 1 to 2 stages
 - High precision
 - Low noise

Leadshine Stepper Systems Quick Selection

Stepper Motors

- Above matched drive is default Pulse & Direction type, other control types of drive also can be matched;
- 3-phase stepper motors still keep selling 3S series, others recommend CM series;
- Contact Leadshine for other customized model such as inch shaft diameters, modified cable, etc.







Phase/ Series	Frame Size	Length(mm)	Model	Rate Current (A)	Holding Torque(N.m)	Matched Drives	Remark	
2- Phase/CM	NEMA 8	33	20CM003	0.6	0.03	EM415S		
		45	20CM005	0.6	0.05	EM415S		
	NEMA 11	32	28CM006	1.2	0.06	EM415S		
		41	28CM010	1.2	0.1	EM415S		
		51	28CM013	1.2	0.13	EM415S		
	NEMA 14	31	35CM015	2.0	0.15	EM422S		
		47	35CM04	2.0	0.4	EM422S		
	NEMA 17	33	42CM02-1A	1.0	0.2	EM415S		
			42CM02	1.5	0.2	EM422S		
		40	42CM04-1A	1.0	0.4	EM415S		
			42CM04	1.5	0.4	EM422S		
		47	42CM06-1A	1.5	0.6	EM422S		
			42CM06	2.5	0.6	EM422S/EM542S	Performance in high-speed	
			42CM06-SZ	2.5	0.6	EM422S/EM542S	Motor with dual shaft	
			42CM08-1A	1.5	0.8	EM422S		
		60	42CM08	2.5	0.8	EM422S/EM542S	Performance in high-speed	
			42CM08-SZ	2.5	0.8	EM422S/EM542S	Motor with dual shaft	
		NEMA 23	41	57CM06	3.0	0.6	EM542S	
			56	57CM13-3A	3.0	1.3	EM542S	
	57CM13			4.0	1.3	EM556S	Performance in high-speed	
	57CM13-SZ			4.0	1.3	EM556S	Motor with dual shaft	
	96		57CM13-BZ	4.0	1.3	EM556S	Motor with brake	
	65		57CM13-FS	4.0	1.3	EM556S	IP65 waterproof	
	76		57CM23-3A	3.0	2.3	EM542S		
			57CM23-4A	4.0	2.3	EM556S		
			57CM23	5.0	2.3	EM556S/EM870S	Performance in high-speed	
	57CM23-SZ		5.0	2.3	EM556S/EM870S	Motor with dual shaft		
			116	57CM23-BZ	5.0	2.3	EM556S/EM870S	Motor with brake
	90		57CM23-FS	5.0	2.3	EM556S/EM870S	Motor with waterproof	
	84		57CM26-4A	4.0	2.6	EM556S		
			57CM26	5.0	2.6	EM556S/EM870S	Performance in high-speed	
			57CM26-SZ	5.0	2.6	EM556S/EM870S	Motor with dual shaft	
	67		D57CM21-4A	4.0	2.1	EM556S		
			D57CM21	5.0	2.1	EM556S/EM870S	Performance in high-speed	
			D57CM21-SZ	5.0	2.1	EM556S/EM870S	Motor with dual shaft	
	88	D57CM31-4A	4.0	3.1	EM556S			
D57CM31		5.0	3.1	EM556S/EM870S	Performance in high-speed			
D57CM31-SZ		5.0	3.1	EM556S/EM870S	Motor with dual shaft			

Phase/Series	Frame Size	Length(mm)	Model	Rate Current (A)	Holding Torque(N.m)	Matched Drives	Remark
2-Phase/CM	NEMA 24	67	60CM22X	5.0	2.2	EM556S/EM870S	Motor with dual shaft
			60CM22X-SZ	5.0	2.2	EM556S/EM870S	Motor with brake
		110	60CM35X-FS	5.0	2.2	EM556S/EM870S	
		85	60CM30X	5.0	3.0	EM556S/EM870S	
			60CM30X-SZ	5.0	3.0	EM556S/EM870S	Motor with dual shaft
		124	60CM30X-BZ	5.0	3.0	EM556S/EM870S	Motor with brake
	NEMA 34	65	86CM35	4.0	3.5	EM556S/EM870S	
		80	86CM45	6.0	4.5	EM882S	
			86CM45-SZ	6.0	4.5	EM882S	Motor with dual shaft
		114	86CM45-BZ	6.0	4.5	EM882S	Motor with brake
		90	86CM45-FS	6.0	4.5	EM882S	Motor with waterproof
		98	86CM80	6.0	8.0	EM882S	
		118	86CM85	6.0	8.5	EM882S	
			86CM85-SZ	6.0	8.5	EM882S	Motor with dual shaft
		152	86CM85-BZ	6.0	8.5	EM882S	Motor with brake
		130	86CM85-FS	6.0	8.5	EM882S	Motor with waterproof
		129	86CM120	6.0	12	EM882S/DM1182	
		NEMA 42	115	110CM12	6.0	12	DM2282
150	110CM20		6.5	20	DM2282		
201	110CM28		6.0	28	DM2282		
NEMA 51	283	130HS45	7.0	45	DM2282		
3-Phase/3S	NEMA 23	50	573S09	3.5	0.9	3DM580S	
		76	573S15	5.8	1.5	3DM580S	
		80	573S20-LS	5.8	1.5	3DM580S	
	NEMA 34	71	863S22	5.0	2.2	3DM883	
		103	863S42	5.0	4.2	3DM883	
		135	863S68H	2.3	6.8	3DM2283	

Phase/Series	Frame Size	Length(mm)	Model	Rate Current (A)	Holding Torque(N.m)	Matched Drives	Remark	
2-Phase/CM	NEMA 11	51	28CM013-ZK	1.2	0.13	EM415S	Hollow shaft	
		40	42CM04-ZK	2.5	0.4	EM422S	Hollow shaft	
			42CM06-BZ	2.0	0.6	EM422S	Brake	
	NEMA 17	79	42CM06-BZ	2.0	0.6	EM422S	Brake	
		88	42CM06-RD05	2.5	0.6	EM422S/EM542S	Gearbox	
		88	42CM06-RD10	2.5	-	EM422S/EM542S	Gearbox	
		95	42CM06-RD20	2.5	-	EM422S/EM542S	Gearbox	
		92	42CM08-BZ	2.0	0.8	EM422S/EM542S	Brake	
		101	42CM08-RD05	2.5	-	EM422S/EM542S	Gearbox	
		101	42CM08-RD10	2.5	-	EM422S/EM542S	Gearbox	
		108	42CM08-RD20	2.5	-	EM422S/EM542S	Gearbox	
		60	42CM08-SZ-ZK	2.5	0.8	EM422S/EM542S	Hollow shaft	
		NEMA 23	55	57CM12C-3A-CZ	3.0	1.2	EM542S	Plug-in terminals
			55	57CM12C-ZK	4.0	1.2	EM542S/EM556S	Hollow shaft
	110		57CM12C-RD05	4.0	-	EM542S/EM556S	Gearbox	
	110		57CM12C-RD10	4.0	-	EM542S/EM556S	Gearbox	
	76		57CM22C-4A-16-CZ	4.0	2.2	EM556S	Plug-in terminals	
	131		57CM22C-RD05	5.0	-	EM556S	Gearbox	
	131		57CM22C-RD10	5.0	-	EM556S	Gearbox	
	NEMA 34		98	86CM80-ZK	6.0	8.0	EM556S	Hollow shaft

Stepper Motors

☑ : Support ☐ : Not Support

Series	Model	Matched Motor Series	Command Source					Electrical Parameters				Motion Function Features					I/O		Others		
			EtherNet/IP	EtherCAT	RS485 Modbus	Pul&Dir	CW&CCW	Power Voltage	Output Current	Logical Voltage		Alarm Output	Brake Output	Self Test	Anti-resonance	Auto-tuning Disable	Digital Input	Digital Output	Mechanical Size (mm)	Tuning Cable	Tuning Software
	2EM3EIP-522	CM Series	☑					20-50VDC	0.5-2.2A	12-24V		☑	☑	☑	☑	☑	2*4	2*2	155*116.5*28	CABLE-MUSB1M5	Motion Studio
	2EM3EIP-556		☑					20-50VDC	1.0-5.6A	12-24V		☑	☑	☑	☑	☑	2*4	2*2	155*116.5*28		
	2EM3EIP-870		☑					20-80VDC	1.0-7.0A	12-24V		☑	☑	☑	☑	☑	2*4	2*2	155*116.5*28		
2EM3E-522			☑					20-50VDC	0.5-2.2A	12-24V		☑	☑	☑	☑	☑	2*4	2*2	155*116.5*28		
2EM3E-556			☑					20-50VDC	1.0-5.6A	12-24V		☑	☑	☑	☑	☑	2*4	2*2	155*116.5*28		
2EM3E-870			☑					20-80VDC	1.0-7.0A	12-24V		☑	☑	☑	☑	☑	2*4	2*2	155*116.5*28		
	EM3E-522B							20-50VDC	0.3-2.2A	12-24V		☑	☑	☑	☑	☑	6	2	118*90*28	CABLE-TYPEC2M0	
	EM3E-556B							20-50VDC	1.0-5.6A	12-24V		☑	☑	☑	☑	☑	6	2	118*90*28		
	EM3E-570B							20-50VDC	1.0-7.0A	12-24V		☑	☑	☑	☑	☑	6	2	118*90*28		
EM3E-A882								18-80VAC 30-110VDC	2.1-8.2A	12-24V		☑	☑	☑	☑	☑	7	7	151*113*40	CABLE-MUSB1M5	Standard ProTuner
	EM2RS-522							20-50VDC	0.3-2.2A	12-24V		☑	☑	☑	☑	☑	7	3	118*79.5*25.5	CABLE-PC-1	Motion Studio
	EM2RS-556							20-50VDC	0.5-5.6A	12-24V		☑	☑	☑	☑	☑	7	3	118*79.5*25.5		
	EM2RS-870							20-80VDC	0.5-7.0A	12-24V		☑	☑	☑	☑	☑	7	3	118*79.5*25.5		
	EM2RS-A882							18-80VAC 30-110VDC	0.5-8.2A	12-24V		☑	☑	☑	☑	☑	7	3	151*97*53		
	EM415S(V2.0)						☑	☑	12-40VDC	0.3-1.5A	5V		☑	☑	☑	☑	3	1	86*55*20	CABLE-PC-1	Standard ProTuner
	EM422S(V2.0)						☑	☑	12-40VDC	0.3-2.2A	5V		☑	☑	☑	☑	3	1	86*55*20		
	EM532MINI						☑		18-50VDC	0.3-3.2A	5V		☑	☑	☑	☑	3	1	62*50*26		
	EM542S(V3.0)						☑	☑	20-50VDC	0.5-4.2A	5/24V		☑	☑	☑	☑	3	2	118*75.5*25.5		
	EM556S(V3.0)					☑	☑	20-50VDC	0.5-5.6A	5/24V		☑	☑	☑	☑	3	2	118*75.5*34			
	EM870S(V3.0)					☑	☑	20-80VDC	0.5-7.0A	5/24V		☑	☑	☑	☑	3	2	118*75.5*34			
	EM882S					☑	☑	20-80VDC	0.5-8.2A	5V		☑	☑	☑	☑	3	1	151*97*48			
	DM322E					☑		12-30VDC	0.3-2.2A	5V		☑	☑	☑	☑	3	0	86*55*20	/		
	DM332E					☑		12-30VDC	1.0-3.2A	5V		☑	☑	☑	☑	3	0	86*55*20	/		
	DM542E(V3.0)					☑		20-50VDC	1.0-4.2A	5/24V		☑	☑	☑	☑	3	0	118*75.5*25.5	CABLE-PC-1	Standard ProTuner	
	DM556E(V3.0)					☑		20-50VDC	1.7-5.6A	5/24V		☑	☑	☑	☑	3	0	118*75.5*34	CABLE-PC-1	Standard ProTuner	
	DM860E					☑	☑	20-80VDC	2.4-7.2A	5V		☑	☑	☑	☑	3	0	151*97*42.5	/		
	DMA860E(V3.0)					☑	☑	18-80VAC 30-110VDC	2.4-7.2A	5/24V		☑	☑	☑	☑	3	2	151*97*57	CABLE-PC-1	Standard ProTuner	
	DMA860H					☑	☑	18-80VAC 30-110VDC	2.4-7.2A	5V		☑	☑	☑	☑	3	0	151*97*53	/		
	DMA882S					☑	☑	18-80VAC 30-110VDC	0.5-8.2A	5V		☑	☑	☑	☑	3	1	151*97*53	CABLE-PC	Standard ProTuner	
	Dm1182	HS&CM Series				☑	☑	70-130VAC	0.5-8.2A	5V		☑	☑	☑	☑	3	1	200*145*83		CABLE-PC	DMSeries ProTuner
	Dm2282					☑	☑	180-240VAC	0.5-8.2A	5V		☑	☑	☑	☑	3	1	200*145*83			
	3DM580S	3S Series					☑	☑	20-50VDC	0.5-8.0A	5/24V		☑	☑	☑	☑	3	1	118*75.5*34	CABLE-PC-1	Standard ProTuner
	3DM883						☑	☑	20-80VDC	2.2-8.3A	5/24V		☑	☑	☑	☑	3	2	151*97*57		
3DM2283						☑	☑	180-240VAC	2.2-11.7A	5V		☑	☑	☑	☑	3	1	200*145*83			

Closed Loop Stepper Motors

- Below matched drives are Pulse Control type, EtherCAT and Modbus RS485 types are also available;
- 3-phase high voltage closed loop stepper motors are ES2-MH series, others are CS-M series;
- Maximum speed up to 3000 rpm, but depends on power voltage, current and load.

Phase/Series	Frame Size	Length(mm)	Model	Holding Torque(N.m)	Matching Drives	Remark
2-phase/CS-M	NEMA 17	56	CS-M21702	0.2	CS-D507E/CS1-D507S	
		63	CS-M21704	0.4	CS-D507E/CS1-D507S	This motor is not recommended
		70	CS-M21706	0.6	CS-D507E/CS1-D507S	
		83	CS-M21708	0.8	CS-D507E/CS1-D507S	
	NEMA 23	60	CS-M22306	0.6	CS-D507E/CS1-D507S	
		75	CS-M22313	1.3	CS-D507E/CS1-D507S	Replace ES-M22310
		109	CS-M22313B	1.3	CS-D507E/CS1-D507S	Motor with brake
		94	CS-M22313WP	1.3	CS-D507E/CS1-D507S	Motor with waterproof
		95	CS-M22323	2.3	CS-D507E/CS1-D507S	Replace ES-M22320
		131	CS-M22323B	2.3	CS-D507E/CS1-D507S	Motor with brake
		115	CS-M22323WP	2.3	CS-D507E/CS1-D507S	Motor with waterproof
		103	CS-M22326	2.6	CS-D507E/CS1-D507S	
	NEMA 24	86	CS-M22321-L	2.1	CS-D507E/CS1-D507S	NEMA23 motor with large body
		105	CS-M22331-L	3.1	CS-D507E/CS1-D507S	NEMA23 motor with large body
		89	CS-M22422	2.2	CS-D507E/CS1-D507S	
		129	CS-M22422B	2.2	CS-D507E/CS1-D507S	Motor with brake
		113	CS-M22422WP	2.2	CS-D507E/CS1-D507S	Motor with waterproof
		107	CS-M22430	3.0	CS-D507E/CS1-D507S	
		143	CS-M22430B	3.0	CS-D507E/CS1-D507S	Motor with brake
	NEMA 34	130	CS-M22430WP	3.0	CS-D507E/CS1-D507S	Motor with waterproof
		95	CS-M23435	3.5	CS-D1008E	
		109	CS-M23445	4.5	CS-D1008E	
		144	CS-M23445B	4.5	CS-D1008E	Motor with brake
		115	CS-M23445WP	4.5	CS-D1008E	Motor with waterproof
		127	CS-M23480	8.0	CS-D1008E	
		152	CS-M23480B	8.0	CS-D1008E	Motor with brake
		133	CS-M23480WP	8.0	CS-D1008E	Motor with waterproof
		147	CS-M23485	8.5	CS-D1008E	
182		CS-M23485B	8.5	CS-D1008E	Motor with brake	
153		CS-M23485WP	8.5	CS-D1008E	Motor with waterproof	
158		CS-M234120	12	CS-D1008E		
193		CS-M234120B	12	CS-D1008E	Motor with brake	
164	CS-M234120WP	12	CS-D1008E	Motor with waterproof		







Phase/Series	Frame Size	Length(mm)	Model	Holding Torque(N.m)	Matching Drives	Remark
3-phase/ES2-MH	NEMA 34	157	ES2-MH33480	8.0	ES-DH2306	
		190	ES2-MH33480B	8.0	ES-DH2306	Motor with brake
		162	ES2-MH33480WP	8.0	ES-DH2306	Motor with waterproof
		184	ES2-MH334100	10	ES-DH2306	
		218	ES2-MH334100B	10	ES-DH2306	Motor with brake
		191	ES2-MH334100WP	10	ES-DH2306	Motor with waterproof
	NEMA 42	162	ES2-MH342120	12	ES-DH2306	
		207	ES2-MH342120B	12	ES-DH2306	Motor with brake
		167	ES2-MH342120WP	12	ES-DH2306	Motor with waterproof
		244	ES2-MH342200	20	ES-DH2306	

Phase/Series	Frame Size	Length(mm)	Model	Holding Torque(N.m)	Matching Drives	Remark
2-phase/CS-M	NEMA 8	51	CS-M208003	0.03	CS-D507E	-
	NEMA 11	62	CS-M211013	0.13	CS-D507E	-
	NEMA 17	93	CS-M21704B	0.4	CS-D507E	Brake
		101	CS-M21706B	0.6	CS-D507E	Brake
		113	CS-M21708B	0.8	CS-D507E	Brake
	NEMA 23	96	CS-M22323-S	2.3	CS-D507E	1/4-inch shaft diameter
		96	CS-M22323-E5Z	2.3	CS-D507E	5000-line
		104	CS-M22326-S	2.6	CS-D507E	1/4-inch shaft diameter
		105	CS-M22331-L-S	3.1	CS-D507E	3/8-inch shaft diameter
		107	CS-M22430-I14	3.0	CS-D507E	AC servo flange
	NEMA 24	147	CS-M22430B-I14	3.0	CS-D507E	AC servo flange, Brake
		107	CS-M22430-E5Z	3.0	CS-D507E	5000-line
		143	CS-M22430B-E5Z	3.0	CS-D507E	Brake, 5000-line
		109	CS-M22445-S	4.5	CS-D1008E	1/2-inch shaft diameter
	NEMA 34	109	CS-M22445-E5Z	4.5	CS-D1008E	5000-line
		135	CS-M22445B-E5Z	4.5	CS-D1008E	Brake, 5000-line
		127	CS-M23480-S	8.0	CS-D1008E	1/2-inch shaft diameter
		127	CS-M23480-E5Z	8.0	CS-D1008E	5000-line
		147	CS-M23485-S	8.5	CS-D1008E	1/2-inch shaft diameter
		147	CS-M23485-E5Z	8.5	CS-D1008E	5000-line
		172	CS-M23485B-E5Z	8.5	CS-D1008E	Brake, 5000-line
		158	CS-M234120-E5Z	12	CS-D1008E	5000-line
		184	CS-M234120B-E5Z	12	CS-D1008E	Brake, 5000-line

Note: Contact Leadshine for Gearboxes and Encoder information.











Closed Loop Stepper Drives

☑ : Support ☐ : Not Support

Series	Model	Matched Motor Series	Command Source				Electrical Parameters				Motion Function Features						I/O		Encoder Resolution (ppr)	Others				
			EtherNet/IP	EtherCAT	RS485 Modbus	Pul&Dir	CW&CCW	Power Voltage	Output Current	Logical Voltage	Alarm Output	Brake Output	Self Test	Fault Reset	Z Signal	Open/Closed Loop Selection	Digital Input	Digital Output		Mechanical Size (mm)	Tuning Cable	Tuning Software		
	2CS3EIP-D503	CS-M	☑				20-50VDC	0.5-2.2A	12-24V			☑	☑		☑	☑	☑	2*4	2*2	1000/5000	155*116.5*28	CABLE-MUSB1M5	Motion Studio	
	2CS3EIP-D507		☑				20-50VDC	1.0-7.0A	12-24V			☑	☑		☑	☑	☑	2*4	2*2		155*116.5*28			
	2CS3E-D503			☑			20-50VDC	0.5-2.2A	12-24V			☑	☑		☑	☑	☑	2*4	2*2		155*116.5*28			
	2CS3E-D507			☑			20-50VDC	1.0-7.0A	12-24V			☑	☑		☑	☑	☑	2*4	2*2		155*116.5*28			
	CS3E-D503B			☑			20-50VDC	0.1-3.0A	12-24V			☑	☑		☑	☑	☑	6	2		118*90*28			CABLE-TYPEC2M0
	CS3E-D507B			☑			20-50VDC	0.1-7.0A	12-24V			☑	☑		☑	☑	☑	6	2		118*90*28			
	CS3E-D1008			☑			18-80VAC 30-110VDC	0.5-8.0A	12-24V			☑	☑		☑	☑	☑	7	7		151*113*40	CABLE-MUSB1M5		
	CS2RS-D503				☑		20-50VDC	0.3-3.0A	12-24V			☑	☑		☑	☑	☑	7	3		118*79.5*25.5	CABLE-PC-1		
	CS2RS-D507				☑		20-50VDC	0.5-7.0A	12-24V			☑	☑		☑	☑	☑	7	3		118*79.5*25.5			
	CS2RS-D1008				☑		18-80VAC 30-110VDC	0.5-8.0A	12-24V			☑	☑		☑	☑	☑	7	3		151*97*53			
	CS1-D503S					☑	☑	20-50VDC	0.5-3.0A	5 / 24V			☑	☑	☑	☑	☑	4	6		118*79.5*25.5			
	CS1-D507S					☑	☑	20-50VDC	0.5-7.0A	5 / 24V			☑	☑	☑	☑	☑	4	6		118*79.5*25.5			
	CS1-D728S				☑	☑	20-72VDC	0.5-8.0A	5 / 24V			☑	☑	☑	☑	☑	4	6	118*79.5*25.5					
	CS-D403				☑	☑	20-50VDC	0.3-3.0A	5V			☑	☑		☑	☑	3	1	116*69.2*26.5	CABLE-PC	ProTuner CS_V3.0			
	CS-D508				☑	☑	20-50VDC	0.5-7.0A	5V			☑	☑		☑	☑	3	1	116*69.2*26.5					
	CS-D808				☑	☑	20-80VDC	0.5-8.0A	5V			☑	☑		☑	☑	3	1	151*97*53					
	CS-D1008				☑	☑	18-80VAC 30-110VDC	0.5-8.0A	5V			☑	☑		☑	☑	3	1	151*97*53					
	CS-D507E				☑	☑	20-50VDC	0.5-7.0A	5 / 24V			☑	☑		☑	☑	3	2	116*69.2*26.5	CABLE-PC-1	Motion Studio			
	CS-D1008E				☑	☑	18-80VAC 30-110VDC	0.5-8.0A	5 / 24V			☑	☑		☑	☑	3	2	151*97*53					

Integrated Stepper Motors

☑ : Support ☐ : Not Support

Series	Picture	Model	Frame Size	Motor Type	Length (mm)	Holding Torque (mm)	Control Type					Electrical Parameters			Motion Function Features			I/O		Tuning Cable	Tuning Software
							RS485 Modbus	Pulse&Dir	CW&CCW			Power Voltage (VDC)	Output Current	Logical Voltage	Alarm Output	PR Mode	I/O Configurable	Digital input	Digital output		
iEM		iEM-1703	NEMA17	Open Loop	64	0.3		☑				20-36	0.3-3.0	5V	☑			3	1	CABLE-PC-1	Motion Studio
		iEM-1706			72	0.6		☑				20-36	0.3-3.0	5V	☑			3	1		
		iEM-1708			85	0.8		☑				20-36	0.3-3.0	5V	☑			3	1		
		iEM-RS1706			73	0.6	☑					20-36	0.3-3.0	12-24V	☑	☑		3	1		
		iEM-RS1708			86	0.8	☑					20-36	0.3-3.0	12-24V	☑	☑		3	1		
		iEM-2313			NEMA23	75	1.3		☑	☑			20-50	0.5-6.0	5V	☑			3		
		iEM-2323	96			2.3		☑	☑			20-50	0.5-7.0	5V	☑			3	1		
		iEM-2321-L	89			2.1		☑	☑			20-50	0.5-7.0	5V	☑			3	1		
		iEM-2331-L	109			3.1		☑	☑			20-50	0.5-7.0	5V	☑			3	1		
		iEM-RS2313	78			1.3	☑					20-50	0.5-6.0	12-24V	☑	☑		3	1		
		iEM-RS2323	99			2.3	☑					20-50	0.5-7.0	12-24V	☑	☑		3	1		
		iEM-2430	NEMA24			109	3.0		☑	☑			20-50	0.5-7.0	5V	☑			3		
iEM-2435		122		3.5			☑	☑			20-50	0.5-7.0	5V	☑			3	1			
iCS		iCS-1703	NEMA17	Closed Loop (14-bit magnetic encoder)	64	0.3		☑				20-36	0.3-3.0	5V	☑		☑	3	1		
		iCS-1706			72	0.6		☑				20-36	0.3-3.0	5V	☑		☑	3	1		
		iCS-1708			85	0.8		☑				20-36	0.3-3.0	5V	☑		☑	3	1		
		iCS-RS1706			73	0.6	☑					20-36	0.3-3.0	12-24V	☑	☑	☑	3	1		
		iCS-RS1708			86	0.8	☑					20-36	0.3-3.0	12-24V	☑	☑	☑	3	1		
		iCS-2313			NEMA23	75	1.3		☑	☑			20-50	0.5-6.0	5V	☑		☑	3	1	
		iCS-2323	96			2.3		☑	☑			20-50	0.5-7.0	5V	☑		☑	3	1		
		iCS-2321-L	89			2.1		☑	☑			20-50	0.5-7.0	5V	☑		☑	3	1		
		iCS-2331-L	109			3.1		☑	☑			20-50	0.5-7.0	5V	☑		☑	3	1		
		iCS-RS2313	78			1.3		☑				20-50	0.5-6.0	12-24V	☑	☑	☑	3	1		
		iCS-RS2323	99			2.3	☑					20-50	0.5-7.0	12-24V	☑	☑	☑	3	1		
		iCS-2430	NEMA24			109	3.0		☑	☑			20-50	0.5-7.0	5V	☑		☑	3	1	
iCS-2435		122		3.5			☑	☑			20-50	0.5-7.0	5V	☑		☑	3	1			

Stepper Products

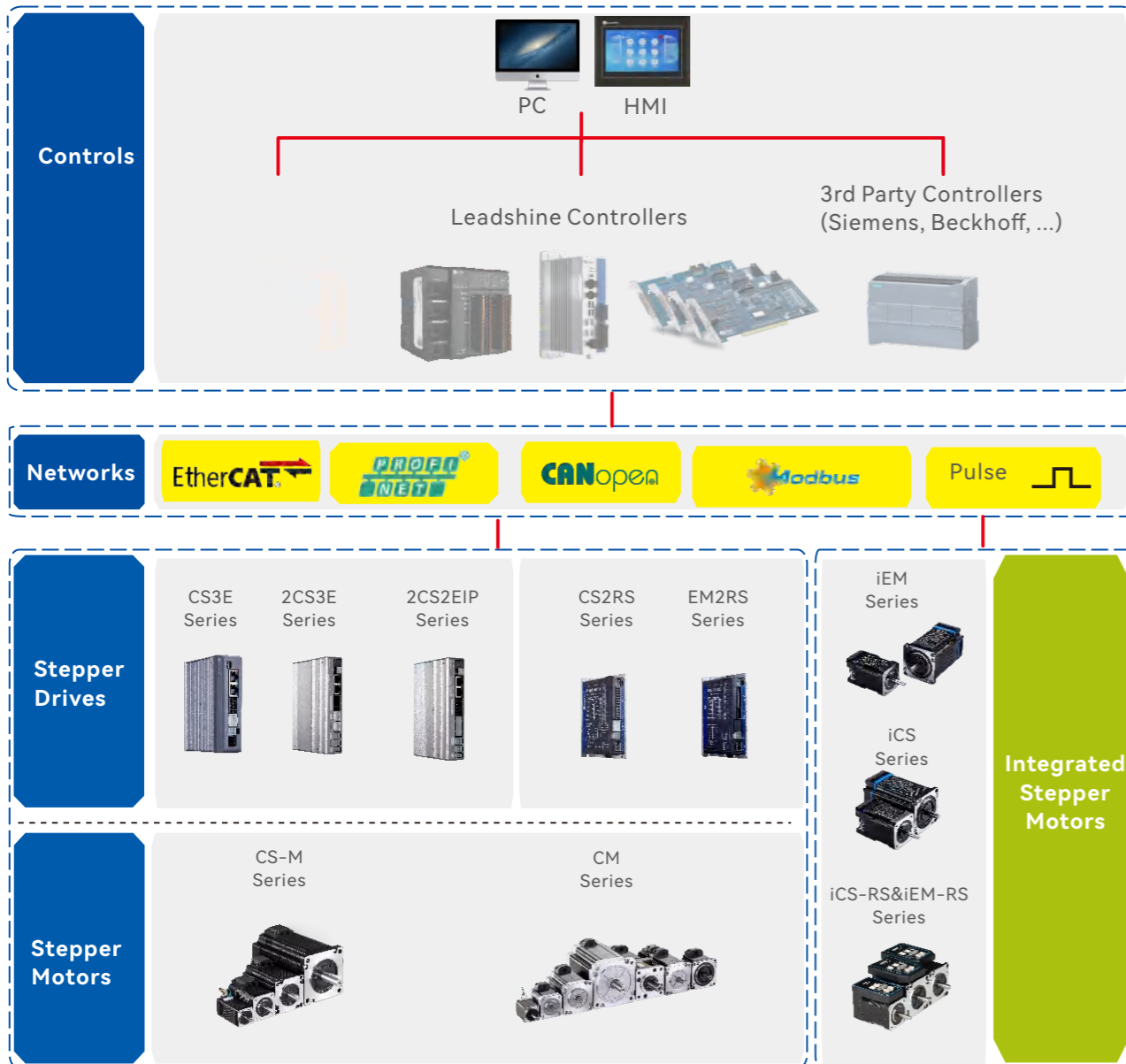

Why Leadshine



Over 30,000,000 installed stepper & servo axes worldwide since 1997

Stepper Drive Part Numbers

EM 5 56 S -

Series Name	
EM	New Series
DM	Classical Series
3DM	3-phase Drive Series

Control Mode	
3E-	EtherCAT Control
2RS-	Rs485 Modbus RTU
Blank	Pulse Control

AC or DC	
Blank	DC
A	AC(except DM1182 and DM2282)

Max Power Voltage	
4	40V
5	50V
8	80V
11	110V±10%
8	120V±10%

Special Control	
IO	5-24V Digital Input Control
IO-24	24V Digital Input Control
V-24	0-10V Analog and 24V Digital Input Control
AI	0-5V Analog Input Control or Pulse Control
500	Max Pulse Frequency 500KHz
CAN	CANopen Control

Grade	
Blank	Standard
E	Economic
S	High Performance

Max Peak Current	
15: 1.5A	56: 5.6A
22: 2.2A	70: 7.0A
32: 3.2A	82: 8.2A
42: 4.2A	83: 8.3A

CM Series Stepper Motors

57 CM 23 - 4A -

Motor Frame Size	
20	20mm (NEMA 8)
28	28mm (NEMA 11)
35	35mm (NEMA 14)
39	39mm (NEMA 16)
42	42mm (NEMA 17)
57/D57	57mm (NEMA 23)
60	60mm (NEMA 24)
86	86mm (NEMA 34)
110	110mm (NEMA 42)
130	130mm (NEMA 51)

Series Name	
CM	New 2-phase Motor Series
HS	Classical 2-phase Motor Series
3S	3-phase Motor Series

Holding Torque	
013: 0.13N.m	30: 3.0N.m
02: 0.2N.m	45: 4.5N.m
06: 0.6N.m	80: 8.0N.m
08: 0.8N.m	85: 8.5N.m
13: 1.3N.m	120: 12N.m
23: 2.3N.m	
For NEMA 42&51	
12: 12N.m	28: 28N.m
20: 20N.m	45: 45N.m
27: 27N.m	

Customized	
Customized Model	

Standard Customized Specification	
Blank	Standard
BZ	Brake
SZ	Dual Shaft
FS	Waterproof (Rate IP65)
O-I6	6.25mm Shaft Diameter
K	NEMA23 Motor Shaft with Key
S30	Shaft Length 30mm
CZ	Plug-in Type Motor
ZK	Hollow Shaft Motor
Rd05	Integrated 1:5 Gearbox
Rd10	Integrated 1:10 Gearbox
Rd20	Integrated 1:20 Gearbox

Rated Current	
Blank	Standard Rated Current
1A	1.5A
3A	3.0A
4A	4.0A

Fieldbus Stepper Drives

2EM3EIP Series

- Support EtherNet/IP fieldbus
- Matching most of master controller



EtherNet/IP Communication

- Support EtherNet/IP communication.
- Support great majority of master station such as Beckhoff, Omron, KEYENCE, Panasonic etc.
- Support position, velocity, and homing control mode.

More Efficient by Dual-axis Control

- One drive controls two axes via one IP address, highly reduce communication load rate.
- Two axes are independently controlled.

STO Optional

- Safe torque off (STO) ensure the safety system.

Saving Mounting Space

- 10% thickness reducing compared to one single-axis drive.
- 50% at least mounting space saving compared to two single-axis drives.

Saving Cost

- One dual-axis drive is more economy than two single-axis drives.

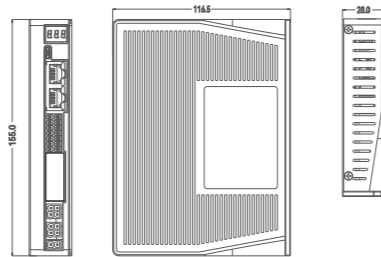

(Unit: mm)

Models	Operating Voltage	Output Current(A)	Matching Motor	Weight(kg)	Dimension(mm)
2EM3EIP-522	20-50VDC	0.5-2.2	NEMA8/11/14/17	0.4	155*116.5*28
2EM3EIP-556	20-50VDC	1.0-5.6	NEMA17/23/24	0.4	155*116.5*28
2EM3EIP-870	20-80VDC	1.0-7.0	NEMA23/24/34	0.4	155*116.5*28
Termination Resistor	The last node needs to add the terminal resistance generally				
CABLE-USB1M5	Tuning cable				
CABLE-TX*M*-BUS	Network Cable: 0.1m, 0.2m, 0.3m, 0.4m, 1m, 1.5m, 2m, 3m,5m,7m, 10m,15m, 20m				

Fieldbus Stepper Drives

2EM3E Series

- Support EtherCAT fieldbus
- Matching most of master controller

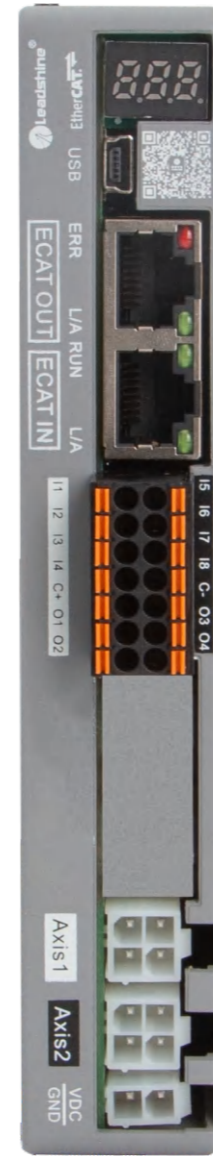

EtherCAT Communication

- Support EtherCAT communication.
- Support great majority of master station such as Beckhoff, Omron, KEYENCE, Panasonic etc.
- Support position, velocity, and homing control mode.

More Efficient by Dual-axis Control

- One drive controls two axes via one IP address, highly reduce communication load rate.
- Two axes are independently controlled.

STO Optional

- Safe torque off (STO) ensure the safety system.

Saving Mounting Space

- 10% thickness reducing compared to one single-axis drive.
- 50% at least mounting space saving compared to two single-axis drives.

Saving Cost

- One dual-axis drive is more economy than two single-axis drives.

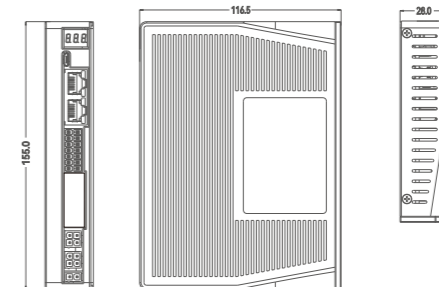

(Unit: mm)

Models	Operating Voltage	Output Current(A)	Matching Motor	Weight(kg)	Dimension(mm)
2EM3E-522	20-50VDC	0.5-2.2	NEMA8/11/14/17	0.4	155*116.5*28
2EM3E-556	20-50VDC	1.0-5.6	NEMA17/23/24	0.4	155*116.5*28
2EM3E-870	20-80VDC	1.0-7.0	NEMA23/24/34	0.4	155*116.5*28
Termination Resistor	The last node needs to add the terminal resistance generally				
CABLE-USB1M5	Tuning cable				
CABLE-TX*M*-BUS	Network Cable: 0.1m, 0.2m, 0.3m, 0.4m, 1m, 1.5m, 2m, 3m,5m,7m, 10m,15m, 20m				

Fieldbus Stepper Drives EM3E Series

- Support CoE control and CiA 402 protocol
- Matching most of master controller
- Conformance tested by ETG



EM3E series drives support operating modes: Profile Position (PP), Profile Velocity (PV), Homing(HM) , Cyclic Synchronous Position (CSP). The products can be matched with most of EtherCAT controller/PLC such as Beckhoff, Omron, Trio, etc.

Features

- Thickness reduce to 28mm, more benefit for mounting
- Friendly type-C tuning port
- Low noise and vibration, smooth motion
- EM3E support standard EtherCAT with operation modes of PP, PV, CSP, HM
- Configurable I/O features: limit switch, alarm, brake, etc
- Optically coupled isolated input, strong anti-interference ability
- Auto-tuning of motor parameters
- Protections for over voltage, over current etc.

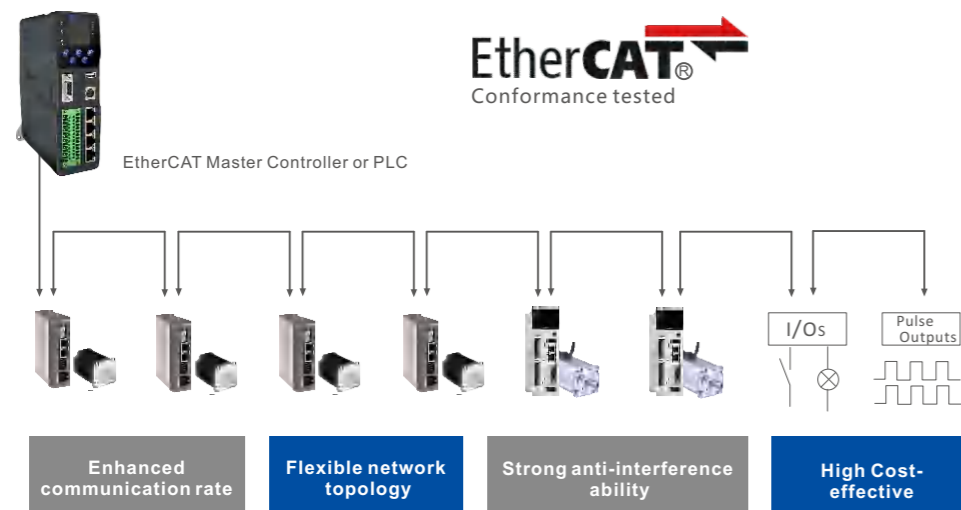

Models	Operating Voltage	Output Current(A)	Matching Motor	Weight(g)	Dimension(mm)
EM3E-522B	20-50VDC	0.3-2.2A	NEMA8/11/14/17	0.57	118*90*28
EM3E-556B	20-50VDC	1.0-5.6A	NEMA17/23/24	0.57	118*90*28
EM3E-570B	20-50VDC	1.0-7.0A	NEMA23/24/34	0.57	118*90*28
EM3E-A882	20-80VAC or 30-100VDC	2.1-8.0A	NEMA34	0.85	151*113*20
CABLE-TYPEC2M0	Tuning Cable				
CABLE-TX*M*-BUS	Network Cable: 0.1m, 0.2m, 0.3m, 0.4m, 1m, 1.5m, 2m, 3m,5m,7m, 10m,15m, 20m				

Fieldbus Stepper Drives EM2RS Series

- Standard Isolated RS485 Modbus
- Smooth motion & Anti-resonance
- Built-in Uni-axial Control Instruction
- HMI, PLC or External I/O start motion



Features

- 7 Programmable Inputs**
 - Limit + / - or Origin inputs
 - Quick stop, Alarm reset and Enable inputs
 - JOG + / - or Position Table inputs
- 3 Programmable Outputs**
 - Alarm, Brake outputs
 - Homing / Instruction / Path complete
- Modes of Operation**
 - Velocity
 - Position
 - Homing
- Support Functions**
 - Teaching
 - Interrupt
 - Skip, Suspend, Circulate motion
- PC Software for Easy Setup, Fine Tune**
- Matching Motors**
 - NEMA8, 11,17, 23, 24, 34
 - Standard, dual shaft, brake, waterproof

1.Support RS485 communication

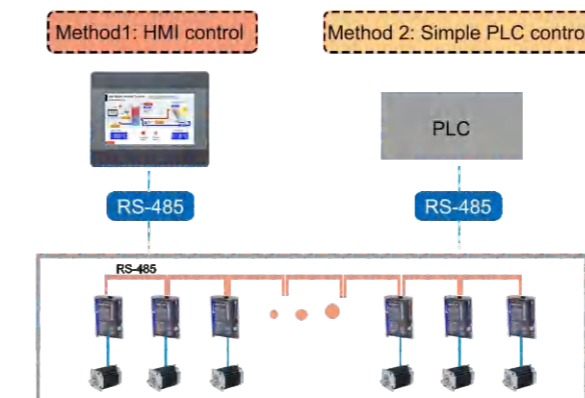

Models	Operating Voltage	Output Current(A)	Matching Motor	Weight(Kg)	Dimension(mm)
EM2RS-522	20-50VDC	0.3-2.2	NEMA8/11/14/17	0.55	118*79.5*25.5
EM2RS-556	20-50VDC	0.5-5.6	NEMA17/23/24	0.55	118*79.5*25.5
EM2RS-870	20-80VDC	0.5-7.0	NEMA23/24/34	0.55	118*79.5*25.5
EM2RS-A882	20-80VAC or 30-100VDC	0.5-8.0	NEMA24/34	0.57	151*97*53
CABLE-PC-1	Tuning Cable				
CABLE-TX*M*-BUS	Network Cable: 0.1m, 0.2m, 0.3m, 0.4m, 1m, 1.5m, 2m, 3m,5m,7m, 10m,15m, 20m				

2. Instruction smoothing

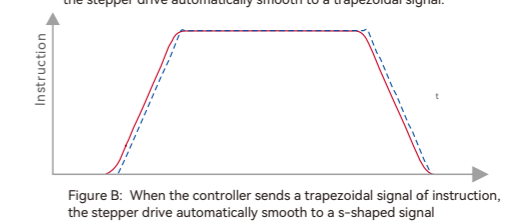
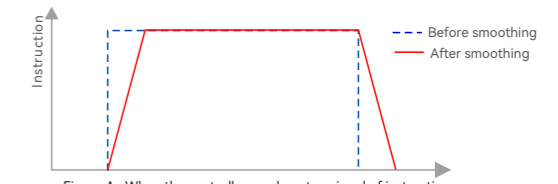

3.Built-in uni-axial control instruction

Programmable 16-segment position table, support positioning/homing/ limit/ quick stop/ JOG...

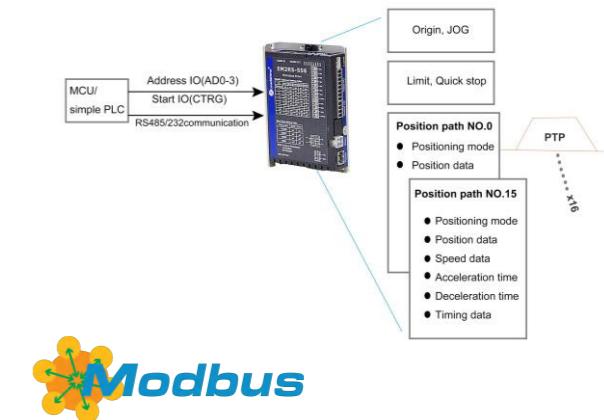

Pulse Control Stepper Drives

EM-S---Enhanced Version
DM-E---Cost-effective Version



EM-S Series----Enhanced Performance

EM-S series stepper drives from Leadshine offer superior performance and exceptional high reliability. Based on Leadshine's 20+ years' experience in stepper motor control, they adopt the latest control technology and are ideal for modern machine manufactures. Not only inheriting features of smooth motion, low noise, low heating, etc. from past Leadshine stepper drives, they also offer new functions and features such as improved torque in all speed ranges, fault output, brake control, pulse command smoothing... They are capable of power wide range of stepper motors of NEMA 8, 11, 15, 17, 23, 34, and 42.

Features

- Torque increased by 10%-25%
- Step & DIR or CW & CCW control
- Alarm and Brake outputs
- 200kHz (500kHz optional) max frequency
- 5V or 24V signal voltage optional
- Soft-start with no "jump"
- Over-voltage, over-current

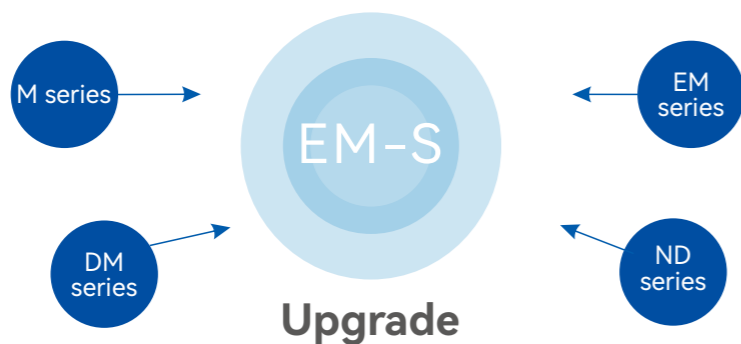

Torque comparison (same condition)

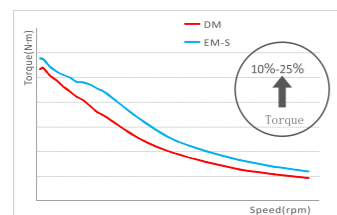

Features of Second DIP Switch

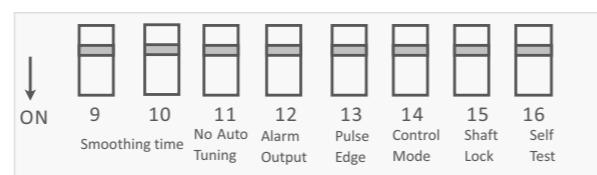

Pulse Smoothing Filter

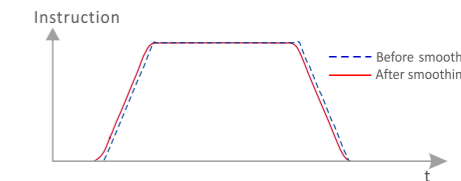
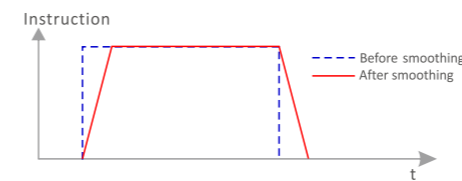

Alarm and Brake Outputs

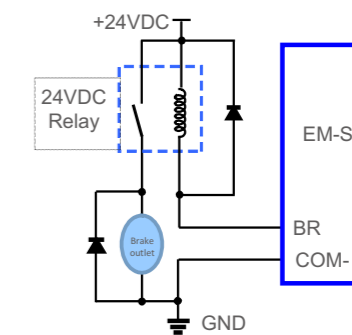
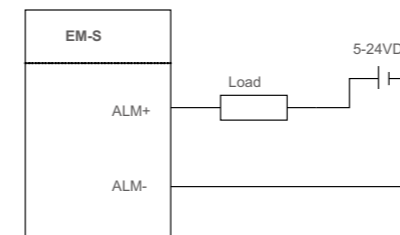

EM-S Series Electrical Specifications

Items	EM415S		EM422S		EM532MINI		EM542S		EM556S		EM870S		EM882S	
	Min	Max	Min	Max	Min	Max	Min	Max	Min	Max	Min	Max	Min	Max
Output Current (A)	0.3	1.5	0.3	22	0.4	3.2	0.5	4.2	0.5	4.2	0.5	7.0	0.5	8.2
Power Voltage (VDC)	12	40	12	40	18	50	20	50	20	50	20	80	20	80
Max Input Frequency (kHz)	-	70	-	70	-	1000	-	200	-	200 or 500*	-	200	-	200 or 500*
Logical Current (mA)	7	16	7	16	7	16	7	16	7	16	7	16	7	16
Logical Voltage (VDC)	0	5	0	5	0	5	0	5 or 24	0	5 or 24	0	5 or 24	0	5
Min Pulse Width (us)	7.5		7.5		0.5		2.5		2.5 or 1		2.5		2.5 or 1	
Matched Motors Size	NEMA 8/11/14/17		NEMA17		NEMA17/23		NEMA17/23		NEMA23/24		NEMA23/24/34		NEMA34	

Note: (*) The drive with 500KHz is another model.

EM-S Series Interface and Dimensions

(unit: mm, 1 inch=25.4 mm)

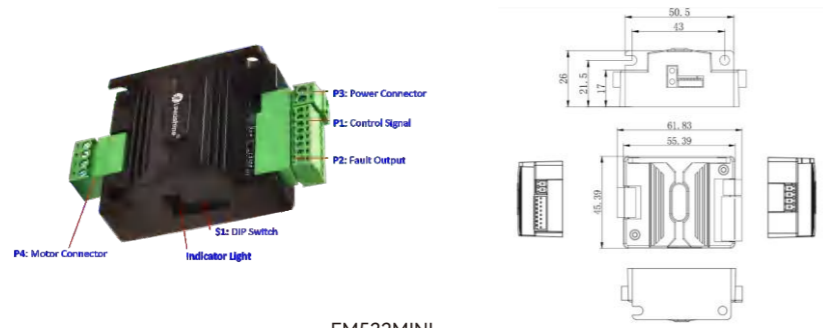

EM532MINI

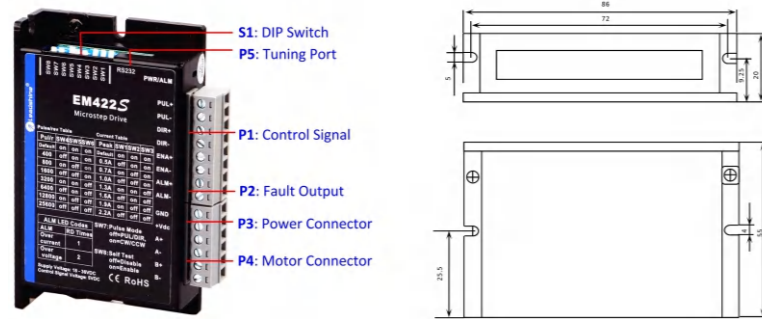

EM415S, EM422S

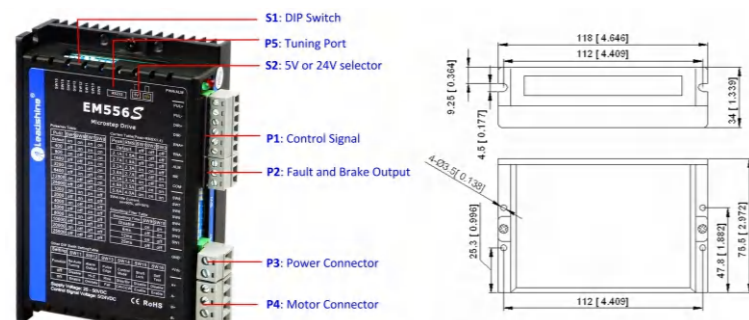

EM542S, EM556S, EM870S

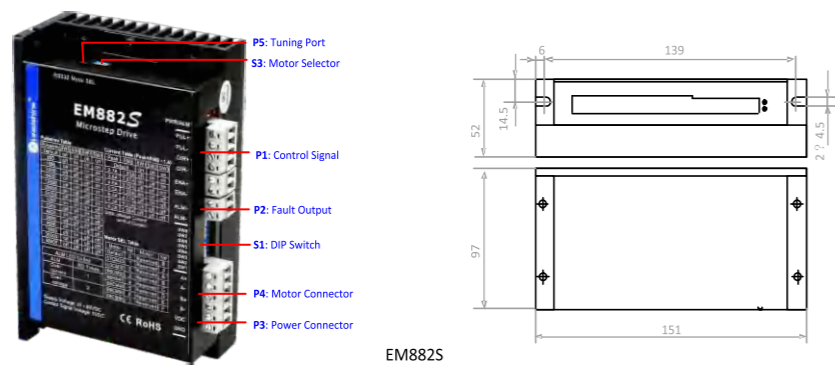

EM882S

DM-E Series---Cost-effective

The DM-E series consists of stepper drives adopting Leadshine latest advanced stepper control technology. Those stepper drives are highly reliable with good performance and highly competitive cost. They can power a wide range of stepper motors from NEMA 8 to NEMA 34 (model dependent). DM-E stepper drives are easy to configure and setup. Output current and micro step resolution can be simply set up via DIP switches.



DM322E	DM332E	DM542E	DM556E	DMA860E
12-30 VDC	12-30 VDC	20-50 VDC	20-50 VDC	20-80 VAC/ 30-110 VDC
0.3-2.2 A	1.0-3.2 A	1.0-4.2 A	1.7-5.6 A	2.4-7.2 A

Dimensions

(unit: mm, 1 inch=25.4 mm)

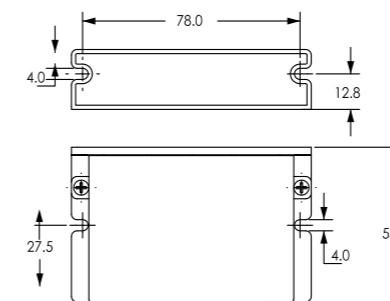

DM322E / DM332E

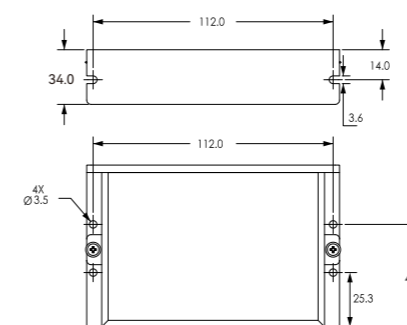

DM556E

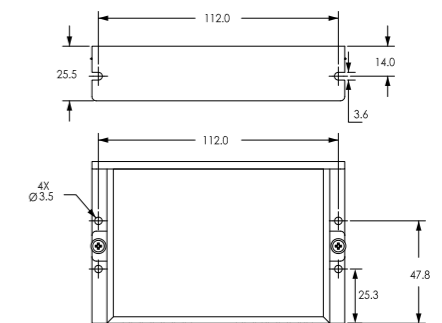

DM542E

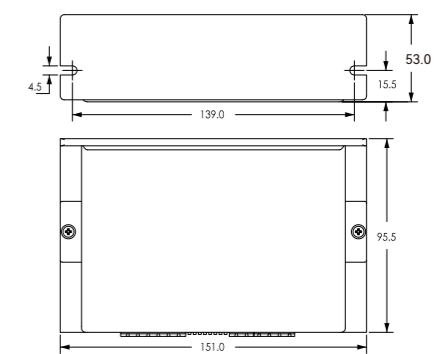

DMA860E

DM Series----AC Power Input

Model	Phase	Power Voltage	Output Current(A)	Control Type	Logical Voltage(VDC)	Mechanical Size(mm)	Matched Motor Size
DMA860H	2	20-80 VAC or 30-110 VDC	2.4-7.2	Step&Dir, CW&CCW	5	151*97*48	NEMA23/24/34
DMA882S	2	20-80 VAC or 30-110 VDC	0.5-8.2	Step&Dir, CW&CCW	5	151*97*48	NEMA23/24/34
DM1182	2	70-130 VAC	0.5-8.2	Step&Dir, CW&CCW	5	202*167*63	NEMA34/42
DM2282	2	180-240 VAC	0.5-8.2	Step&Dir, CW&CCW	5	202*167*63	NEMA34/42/53

DM Series---- 3-phase Type

Model	Phase	Power Voltage	Output Current(A)	Control Type	Logical Voltage(VDC)	Mechanical Size(mm)	Matched Motor Size
3DM580S	3	20-50 VDC	0.5-8.0	Step&Dir, CW&CCW	5	118*76*33	NEMA17/23/24/34
3DM883	3	20-80 VDC	2.2-8.3	Step&Dir, CW&CCW	5	151*97*48	NEMA24/34
3DM2283	3	180-240 VAC	2.2-11.7	Step&Dir, CW&CCW	5	202*167*63	NEMA 34/42/53

Dimensions

(unit: mm, 1 inch=25.4 mm)

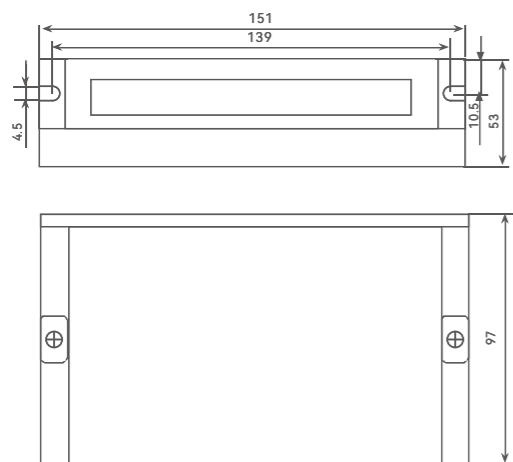

(a) Mechanical specifications of the DMA882S

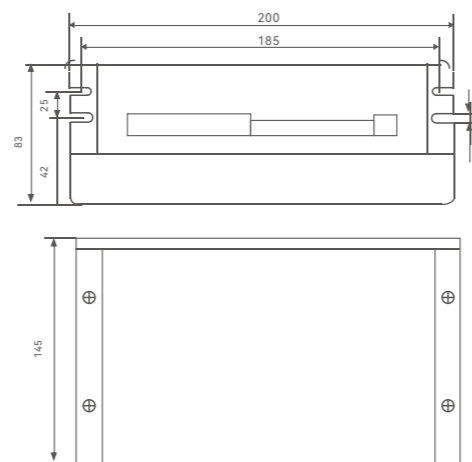

(b) Mechanical specifications of the DM1182

5-phase Stepper Drives

NEW

EtherCat / Pul&Dir

(Coming Soon)



Support EtherCat / Pul&Dir

EtherCAT

5-phase EtherCat Stepper Drives

Pulse

5-phase Pulse Control Stepper Drives

Higher positioning accuracy

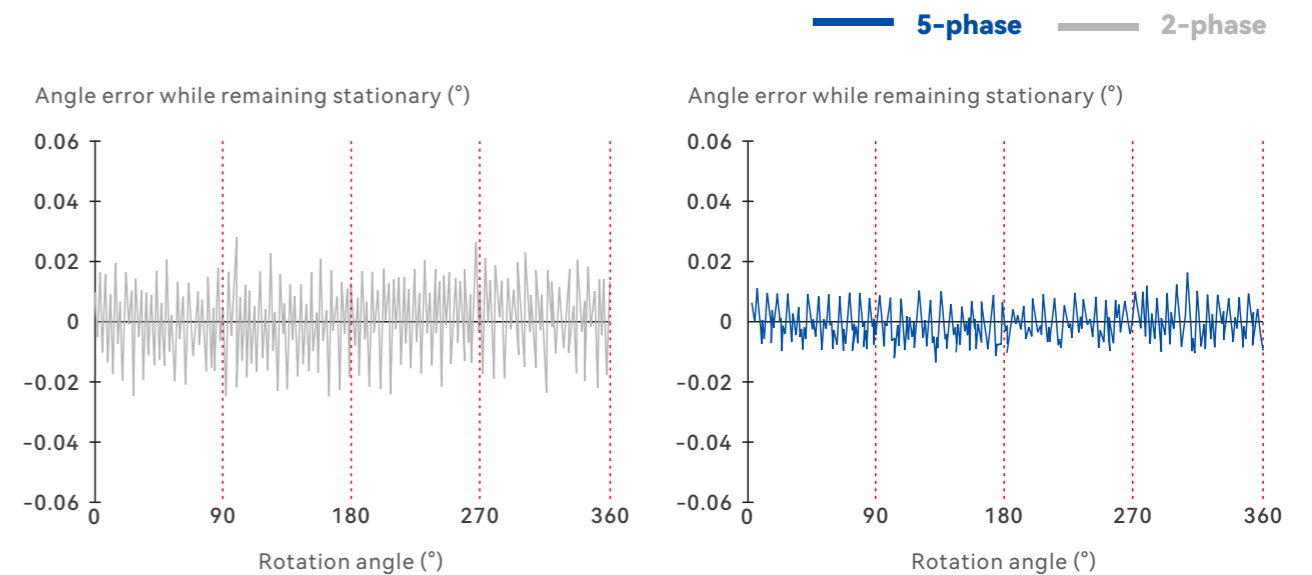

Lower vibration

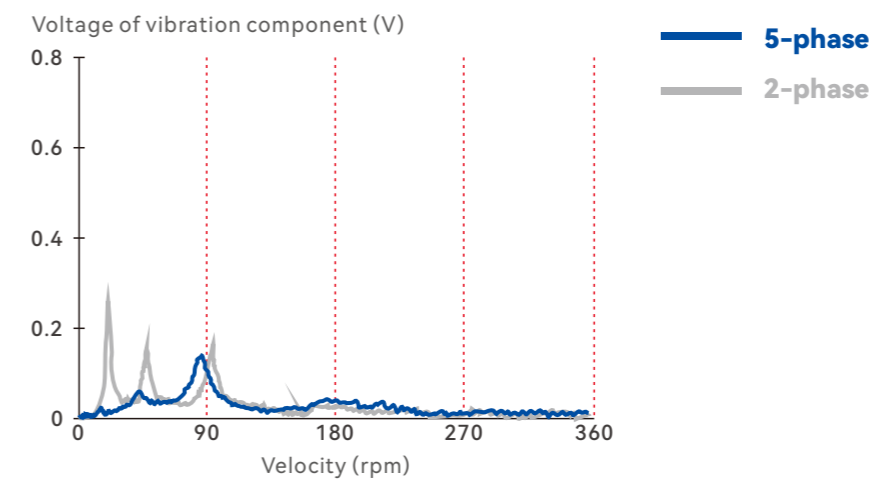

Stepper Motors

CM Series

- Replace HS series stepper motors
- Frame size of NEMA8 to 42
- High reliability, Low motor heating, noise and vibration
- Multiple phase current optional for the same motor



Introduction

By implementing latest design and advanced manufacturing technologies, Leadshine offers hybrid stepper motors in wide frame sizes 8, 11, 14, 16, 17, 23, 24, 34, and 42. Those stepper motors are made of premium quality materials. Compared with ordinary stepper motors on the market. Those stepper motors outperforms in many aspects such as higher torque in all speed ranges, higher precision, lower heating, and lower vibration. Due to the implementation of highly automated manufacturing process and rigid quality assurance control, Leadshine CM series stepper motors are highly reliable with high product consistency.

High Torque:
Latest design for compact size but high torque

Smooth Motion:
Core components from global leading suppliers.

Low Heating:
Use of high quality silicon steel to ensure low motor heating.

High Consistency:
Highly automated manufacturing process and rigid quality control.

Leadshine CM series stepper motors are available in the following options:

- Standard single shaft stepper motors.
- IP 65 waterproof stepper motors.
- Dual shaft stepper motors.
- Stepper motors with electromagnetic brakes.
- Stepper motors with planetary gearboxes.
- Stepper motors with encoders (also called closed loop stepper motors).
- Stepper motors with encoder, brake, and gearboxes.

Leadshine CM stepper motors have been widely implemented in many industrial applications such as CNC routers, laser cutters, plasmas, plotters, medical equipment, battery manufacturing product lines, textile machines, packaging machines, etc.



CM series waterproof stepper motor, compared with the standard type, the back cover is redesigned, the lead wire is changed to waterproof connector, new sealing material is added between the front & back cover and the body, the motor body is made a comprehensive waterproof treatment, the motor shaft is selected high quality oil seal, so that the motor IP rate is IP65. can be applied to all kinds of wet, water, outdoor, oil splashing occasions.



DM Series---AC Power Input

Step Angle	1.8°
Position Accuracy	±0.09°
Temp Rise(Max.)	Max. 85K
Operation Environment	Temperature: -10°C - +50°C; Humidity: Max. 85%
Insulation Class	B
Insulation Resistance	Min. 100 MΩ, 500 V DC
Dielectric Strength	500 VAC, 1 min
Radial Play	0.025 mm Max. (Load 5N)
Axial Play	0.075 mm Max. (Load 10N)

Installation & Operation Conditions

Motor Size	NEMA17	NEMA23	NEMA24	NEMA34
Store Temperature	-10°C ~ +50°C			
Store Humidity	Max. 85%			
Operation Environment	Non-corrosive gas and dust; No direct contact with water, oil (except the waterproof type)			
Radial Load(N) (Distance to the flange 10mm)	30	75	90	300
Axial Load(N)	Less than motor weight			

Stepper Motor Overview

- Below matched drive is default Pulse & Direction type, other control types of drive also can be matched;
- 3-phase stepper motors still keep selling 3S series, others recommend CM series;
- Contact Leadshine for other customized model such as inch shaft diameters, modified cable, etc.

Phase/ Series	Frame Size	Length(mm)	Model	Rate Current (A)	Holding Torque(N.m)	Matched Drives	Remark	
2- Phase/CM	NEMA 8	33	20CM003	0.6	0.03	EM415S		
		45	20CM005	0.6	0.05	EM415S		
	NEMA 11	32	28CM006	1.2	0.06	EM415S		
		41	28CM010	1.2	0.1	EM415S		
		51	28CM013	1.2	0.13	EM415S		
	NEMA 14	31	35CM015	2.0	0.15	EM422S		
		47	35CM04	2.0	0.4	EM422S		
	NEMA 17	33	42CM02-1A	1.0	0.2	EM415S		
			42CM02	1.5	0.2	EM422S		
		40	42CM04-1A	1.0	0.4	EM415S		
			42CM04	1.5	0.4	EM422S		
		47	42CM06-1A	1.5	0.6	EM422S		
			42CM06	2.5	0.6	EM422S/EM542S	Performance in high-speed	
			42CM06-SZ	2.5	0.6	EM422S/EM542S	Motor with dual shaft	
		60	42CM08-1A	1.5	0.8	EM422S		
			42CM08	2.5	0.8	EM422S/EM542S	Performance in high-speed	
			42CM08-SZ	2.5	0.8	EM422S/EM542S	Motor with dual shaft	
		NEMA 23	41	57CM06	3.0	0.6	EM542S	
			56	57CM13-3A	3.0	1.3	EM542S	
	57CM13			4.0	1.3	EM556S	Performance in high-speed	
	57CM13-SZ			4.0	1.3	EM556S	Motor with dual shaft	
	96		57CM13-BZ	4.0	1.3	EM556S	Motor with brake	
	65		57CM13-FS	4.0	1.3	EM556S	IP65 waterproof	
	76		57CM23-3A	3.0	2.3	EM542S		
			57CM23-4A	4.0	2.3	EM556S		
			57CM23	5.0	2.3	EM556S/EM870S	Performance in high-speed	
	57CM23-SZ		5.0	2.3	EM556S/EM870S	Motor with dual shaft		
	116		57CM23-BZ	5.0	2.3	EM556S/EM870S	Motor with brake	
	90		57CM23-FS	5.0	2.3	EM556S/EM870S	Motor with waterproof	
	84		57CM26-4A	4.0	2.6	EM556S		
			57CM26	5.0	2.6	EM556S/EM870S	Performance in high-speed	
			57CM26-SZ	5.0	2.6	EM556S/EM870S	Motor with dual shaft	
	67		D57CM21-4A	4.0	2.1	EM556S		
			D57CM21	5.0	2.1	EM556S/EM870S	Performance in high-speed	
			D57CM21-SZ	5.0	2.1	EM556S/EM870S	Motor with dual shaft	
	88	D57CM31-4A	4.0	3.1	EM556S			
		D57CM31	5.0	3.1	EM556S/EM870S	Performance in high-speed		
		D57CM31-SZ	5.0	3.1	EM556S/EM870S	Motor with dual shaft		

Phase/Series	Frame Size	Length(mm)	Model	Rate Current (A)	Holding Torque(N.m)	Matched Drives	Remark	
2-Phase/CM	NEMA 24	67	60CM22X	5.0	2.2	EM556S/EM870S	Motor with dual shaft	
			60CM22X-SZ	5.0	2.2	EM556S/EM870S	Motor with brake	
		110	60CM35X-FS	5.0	2.2	EM556S/EM870S		
		85	60CM30X	5.0	3.0	EM556S/EM870S		
			60CM30X-SZ	5.0	3.0	EM556S/EM870S	Motor with dual shaft	
	124	60CM30X-BZ	5.0	3.0	EM556S/EM870S	Motor with brake		
	NEMA 34	65	86CM35	4.0	3.5	EM556S/EM870S		
		80	86CM45	6.0	4.5	EM882S		
			86CM45-SZ	6.0	4.5	EM882S	Motor with dual shaft	
		114	86CM45-BZ	6.0	4.5	EM882S	Motor with brake	
		90	86CM45-FS	6.0	4.5	EM882S	Motor with waterproof	
		98	86CM80	6.0	8.0	EM882S		
			86CM85	6.0	8.5	EM882S		
		118	86CM85-SZ	6.0	8.5	EM882S	Motor with dual shaft	
			86CM85-BZ	6.0	8.5	EM882S	Motor with brake	
		152	86CM85-FS	6.0	8.5	EM882S	Motor with waterproof	
		130	86CM120	6.0	12	EM882S/DM1182		
		129	110CM12	6.0	12	DM2282		
		NEMA 42	115	110CM20	6.5	20	DM2282	
			201	110CM28	6.0	28	DM2282	
283			130HS45	7.0	45	DM2282		
3-Phase/3S	NEMA 23	50	573S09	3.5	0.9	3DM580S		
		76	573S15	5.8	1.5	3DM580S		
		80	573S20-LS	5.8	1.5	3DM580S		
	NEMA 34	71	863S22	5.0	2.2	3DM883		
		103	863S42	5.0	4.2	3DM883		
		135	863S68H	2.3	6.8	3DM2283		

Phase/Series	Frame Size	Length(mm)	Model	Rate Current (A)	Holding Torque(N.m)	Matched Drives	Remark	
2-Phase/CM	NEMA 11	51	28CM013-ZK	1.2	0.13	EM415S	Hollow shaft	
	NEMA 17	40	42CM04-ZK	2.5	0.4	EM422S	Hollow shaft	
		79	42CM06-BZ	2.0	0.6	EM422S	Brake	
		88	42CM06-RD05	2.5	0.6	EM422S/EM542S	Gearbox	
		88	42CM06-RD10	2.5	-	EM422S/EM542S	Gearbox	
		95	42CM06-RD20	2.5	-	EM422S/EM542S	Gearbox	
		92	42CM08-BZ	2.0	0.8	EM422S/EM542S	Brake	
		101	42CM08-RD05	2.5	-	EM422S/EM542S	Gearbox	
		101	42CM08-RD10	2.5	-	EM422S/EM542S	Gearbox	
		108	42CM08-RD20	2.5	-	EM422S/EM542S	Gearbox	
		60	42CM08-SZ-ZK	2.5	0.8	EM422S/EM542S	Hollow shaft	
		NEMA 23	55	57CM12C-3A-CZ	3.0	1.2	EM542S	Plug-in terminals
			55	57CM12C-ZK	4.0	1.2	EM542S/EM556S	Hollow shaft
	110		57CM12C-RD05	4.0	-	EM542S/EM556S	Gearbox	
	110		57CM12C-RD10	4.0	-	EM542S/EM556S	Gearbox	
	76		57CM22C-4A-16-CZ	4.0	2.2	EM556S	Plug-in terminals	
	131		57CM22C-RD05	5.0	-	EM556S	Gearbox	
	131		57CM22C-RD10	5.0	-	EM556S	Gearbox	
	NEMA 34		98	86CM80-ZK	6.0	8.0	EM556S	Hollow shaft

Standard Stepper Motor Specifications

NEMA 8 (20mm)



Standard Model:

Model	Length (mm)	Holding Torque(N.m)	Rate Current (A)	Resistance/Phase(Ω)	Inductance/Phase(mH)	Inertia (10 ⁻⁴ kgm ²)	Matched Drives
20CM003	33	0.03	0.6	5.7	2.6	0.003	EM415S
20CM005	45	0.05	0.6	7	3.4	0.004	EM415S

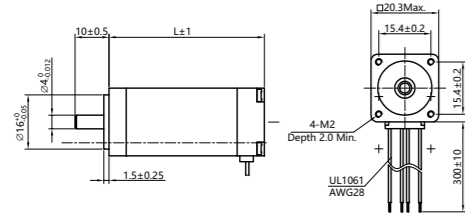

Unit: mm 1inch=25.4mm

NEMA 11 (28mm)



Standard Model:

Model	Length L(mm)	Holding Torque(N.m)	Rate Current (A)	Resistance/Phase(Ω)	Inductance/Phase(mH)	Inertia (10 ⁻⁴ kgm ²)	Matched Drives
28CM006	32	0.06	1.2	1.4	1.0	0.009	EM415S
28CM010	41	0.1	1.2	1.8	1.6	0.013	EM415S
28CM013	51	0.13	1.2	2.2	2.3	0.018	EM415S

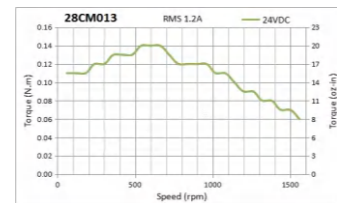
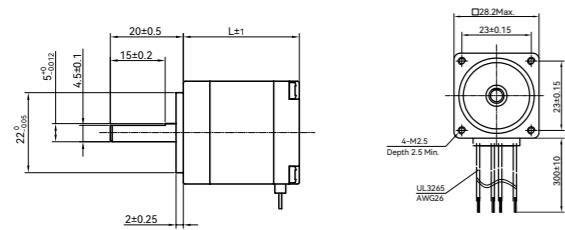

Unit: mm 1inch=25.4mm

NEMA 14 (35mm)



Standard Model:

Model	Length L(mm)	Holding Torque(N.m)	Rate Current (A)	Resistance/Phase(Ω)	Inductance/Phase(mH)	Inertia (10 ⁻⁴ kgm ²)	Matching Drives
35CM015	31	0.15	2	0.8	1.3	0.019	EM422S
35CM04	47	0.36	2	1.2	1.9	0.026	EM422S

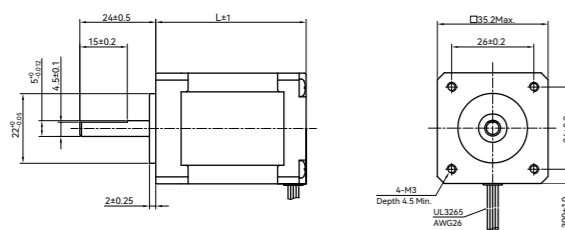

Unit: mm 1inch=25.4mm

NEMA 17 (42mm)



Standard Model:

Model	Length L(mm)	Holding Torque(N.m)	Rate Current (A)	Resistance/Phase(Ω)	Inductance/Phase(mH)	Inertia (10 ⁻⁴ kgm ²)	Matching Drives
42CM02-1A	33	0.21	1	4.5	6.5	0.035	EM415S
42CM02		0.21	1.5	1.4	1.4	0.035	EM422S
42CM04-1A	40	0.4	1	4.0	7.9	0.054	EM415S
42CM04		0.4	1.5	2.3	4.3	0.054	EM422S
42CM06-1A	47	0.6	1.5	2.2	4.5	0.072	EM422S
42CM06		0.6	2.5	0.9	1.6	0.072	EM532MINI
42CM08-1A	60	0.8	1.5	3.0	6.9	0.110	EM422S
42CM08		0.8	2.5	1.0	2.4	0.110	EM532MINI

Unit: mm 1inch=25.4mm

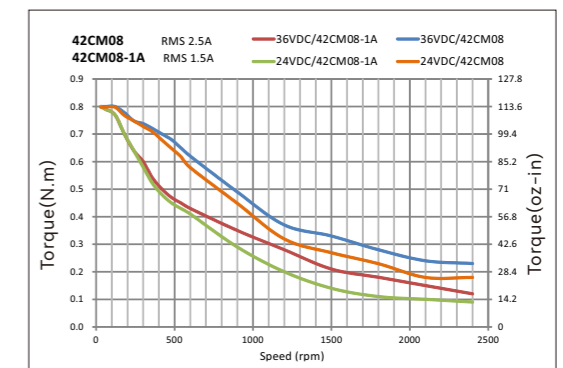
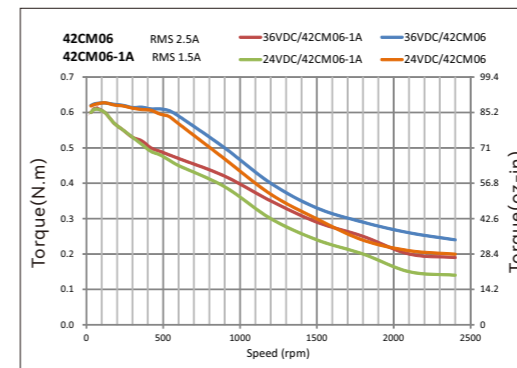
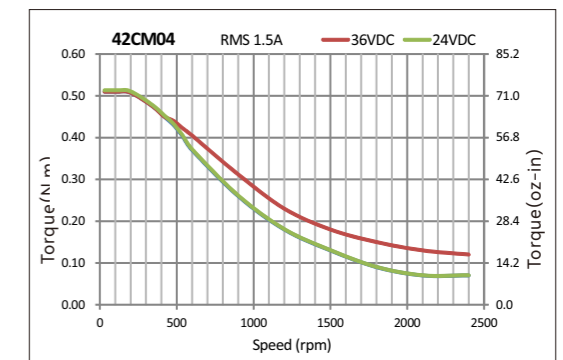
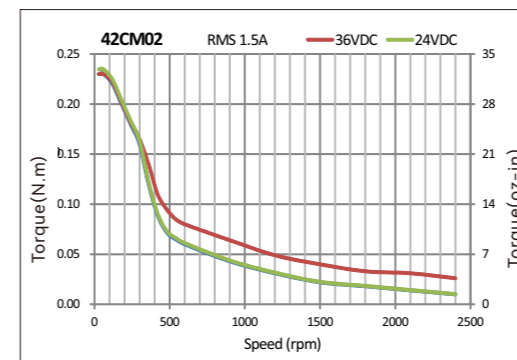
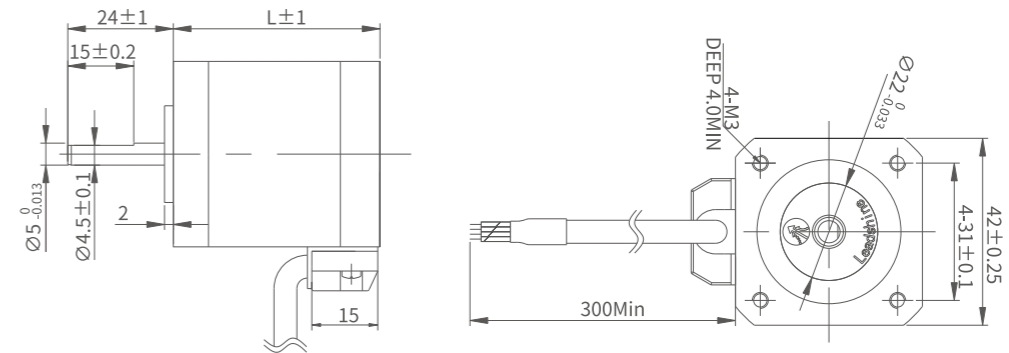

NEMA 23 (57mm)



Standard Model:

Model	Length L(mm)	Holding Torque(N.m)	Rate Current (A)	Resistance/Phase(Ω)	Inductance/Phase(mH)	Detent Torque	Inertia (10 ⁻⁴ kgm ²)	Matching Drives
57CM06	41	0.6	3	0.7	1.4	0.02	0.12	EM542S
57CM13-3A	55	1.3	3	0.8	2.8	0.04	0.3	EM542S
57CM13		1.3	4	0.42	1.6			EM542S/EM556S
57CM12X		1.2	4	0.6	1.4			EM542S/EM556S
57CM21X	76	2.1	4	0.6	2.4	0.07	0.48	EM542S/EM556S
57CM23-3A		2.1	3	1.1	4.2			EM542S
57CM23-4A	76	2.3	4	0.5	2	0.07	0.48	EM542S/EM556S
57CM23		2.3	5	0.38	1.75			EM556S
57CM22X	80	2.2	5	0.34	1.74	0.07	0.5	EM556S/EM870S
57CM26-4A	85	2.6	4	0.8	3.2	0.08	0.52	EM542S/EM556S
57CM26		2.6	5	0.44	2			EM556S/EM870S

Note: Motors with 1/4 in.(6.35mm) shaft diameter are available.

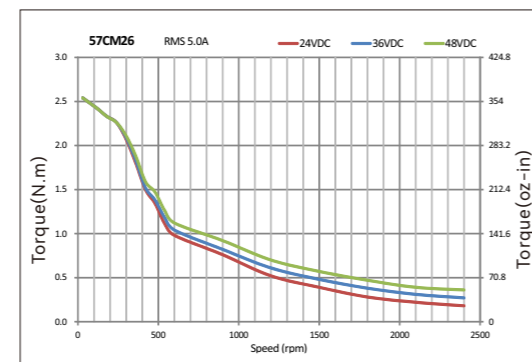
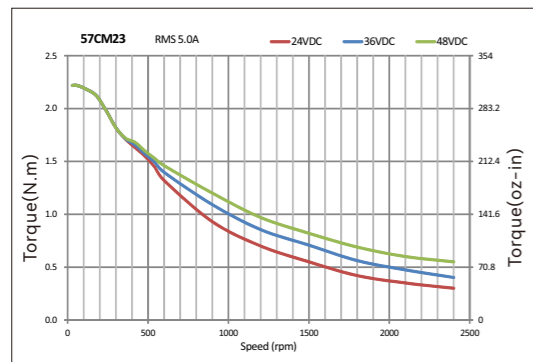
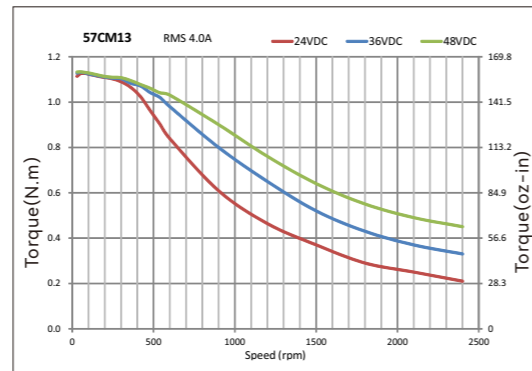
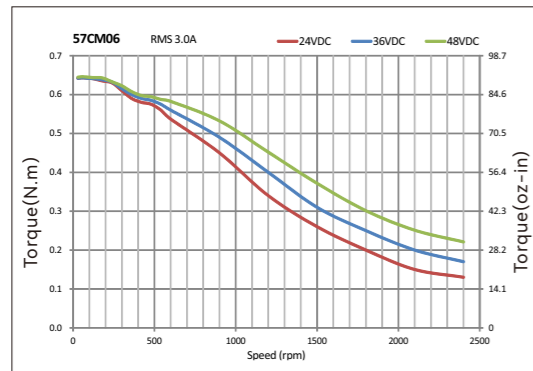
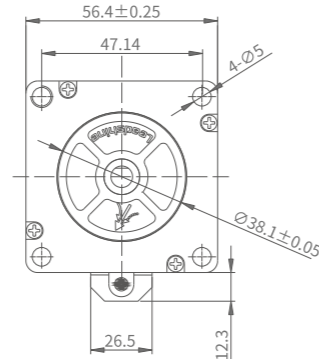
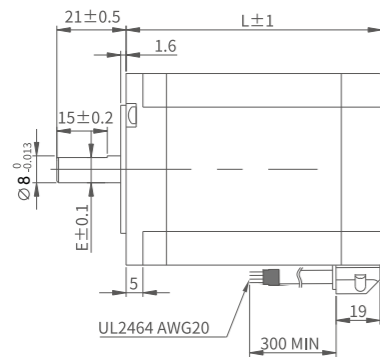

NEMA 23 (57mm)



Standard Model:

Model	Length L(mm)	Holding Torque(N.m)	Rate Current (A)	Resistance/Phase(Ω)	Inductance/Phase(mH)	Detent Torque (N.m)	Inertia (10 ⁻⁴ kgm ²)	Matching Drives
D57CM21-4A	67	2.1	4	0.5	1.77	0.09	0.57	EM556S
D57CM21		2.1	5	0.21	0.75			EM556S/EM870S
D57CM31-4A	88	3.1	4	0.62	2.8	0.10	0.84	EM556S
D57CM31		3.1	5	0.26	1.18			EM556S/EM870S

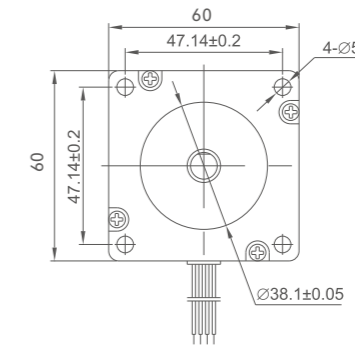
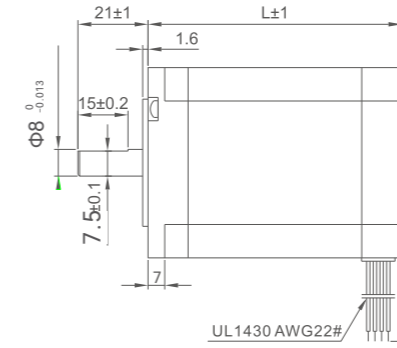

NEMA 24 (60mm)



Standard Model:

Model	Length L(mm)	Holding Torque(N.m)	Rate Current (A)	Resistance/Phase(Ω)	Inductance/Phase(mH)	Detent Torque(N.m)	Inertia (10 ⁻⁴ kgm ²)	Matching Drives
60CM22X	67	2.2	5	0.33	1.05	0.07	0.49	EM556S/EM870S
60CM30X	85	3.0	5	0.46	2.0	0.08	0.69	EM556S/EM870S

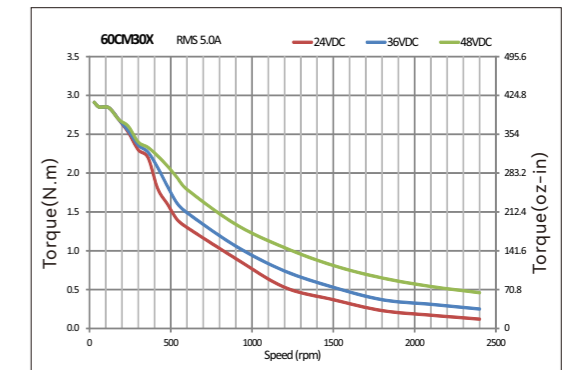
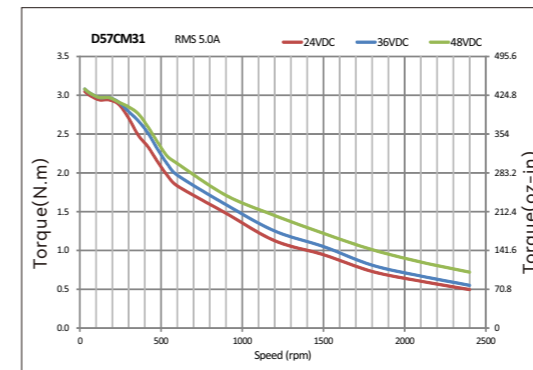
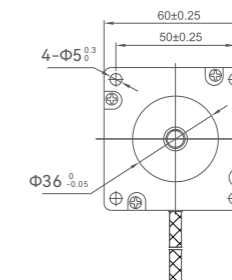
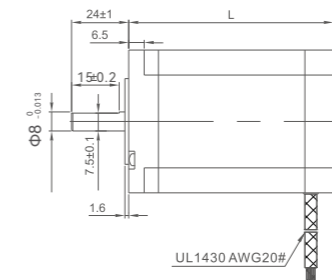

NEMA 34 (86mm)



Standard Model:

Model	Length L(mm)	Holding Torque(N.m)	Rate Current (A)	Resistance/Phase(Ω)	Inductance/Phase(mH)	Inertia (10 ⁻⁴ kgm ²)	Matching Drives
86CM35	65	3.5	4	0.42	2.67	1.00	EM556S/EM870S
86CM45	80	4.5	6	0.43	2.95	1.40	EM882S
86CM80	98	8.0	6	0.63	4.0	2.50	EM882S
86CM85	118	8.5	6	0.53	4.25	2.70	EM882S
86CM120	129	12.0	6	0.75	5.30	2.94	EM882S/DMA882S

Note: Motors with 1/4 in(6.35mm) shaft diameter are available.

Unit: mm 1inch=25.4mm

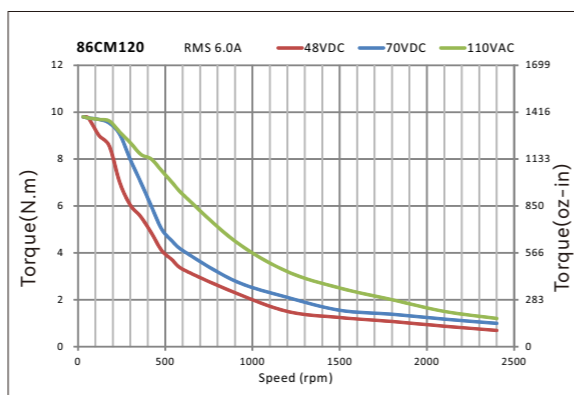
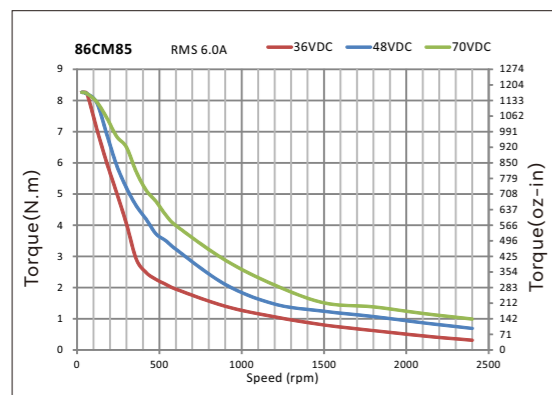
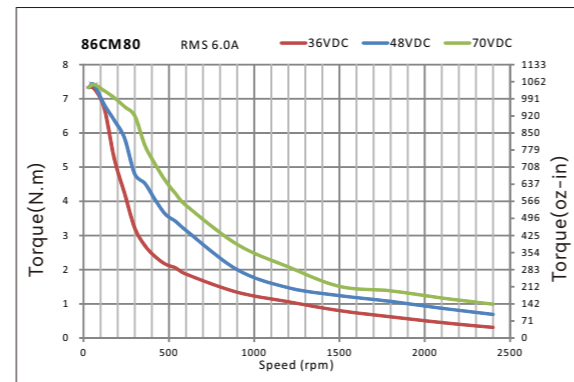
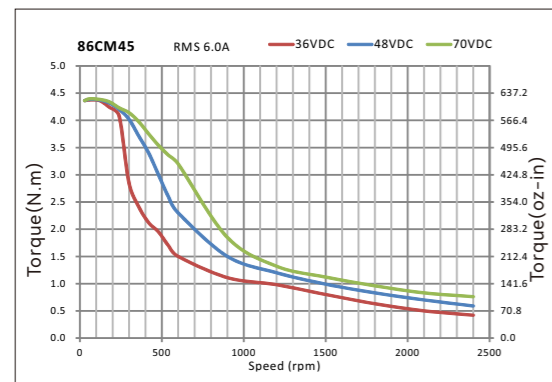
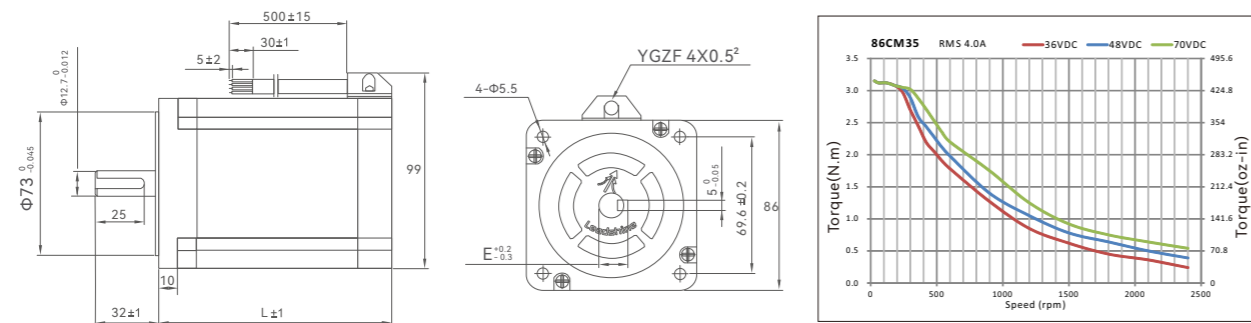

NEMA 42 & 51 (110mm & 130mm)



Standard Model:

Model	Length L(mm)	Holding Torque(N.m)	Rate Current (A)	Resistance/Phase(Ω)	Inductance/Phase(mH)	Inertia (10 ⁻⁴ kgm ²)	Matching Drives
110CM12	115	12	6	0.53	6.5	7.2	DM2282
110CM20	150	20	6	0.8	15	10.9	DM2282
110CM28	201	28	6.5	1.2	22	16.2	DM2282
130HS27	227	27	6	0.86	12.5	15.7	DM2282
130HS45	283	45	7	0.66	9.0	22.9	DM2282

Unit: mm 1inch=25.4mm

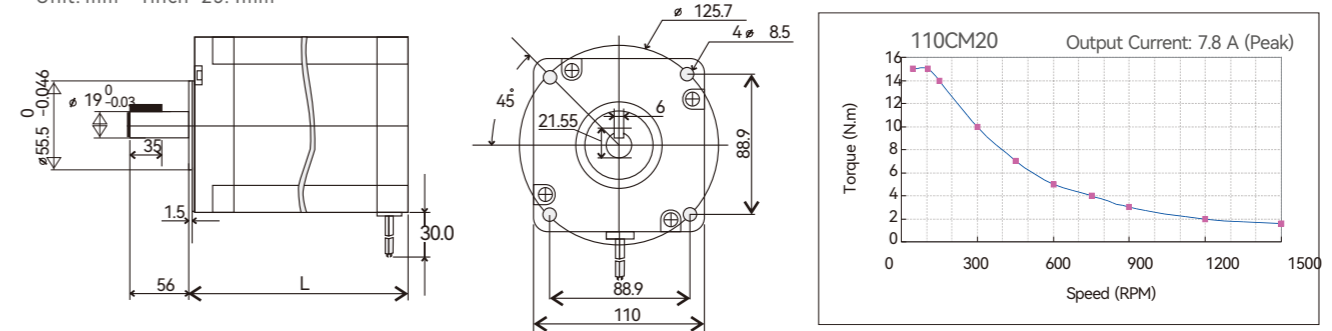

Unit: mm 1inch=25.4mm

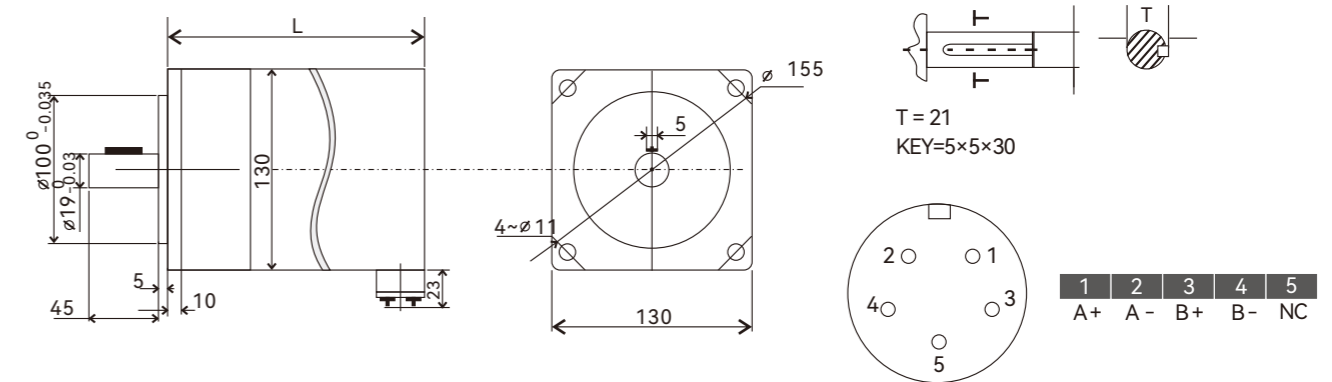

3-phase:NEMA 23, 34, 42



Standard Model:

Model	Length L(mm)	Holding Torque(N.m)	Rate Current (A)	Resistance/Phase(Ω)	Inductance/Phase(mH)	Inertia (10 ⁻⁴ kgm ²)	Matching Drives
573S09	50	0.9	3.5	0.77	1.8	1.00	3DM580S
573S15	76	1.3	5.8	0.86	2.0	1.40	3DM580S
863S22	71	2.3	5	0.9	2.8	2.50	3ND883
863S42	103	4.3	5	1.35	4.5	2.70	3ND883
863S68H	135	6.8	2.3	4.5	20	2.94	3DM2283

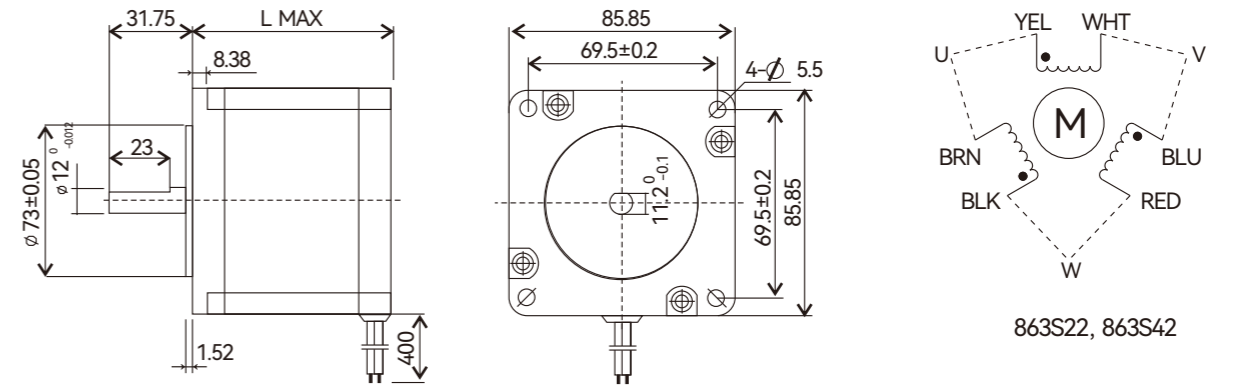

863S22, 863S42

Unit: mm 1inch=25.4mm

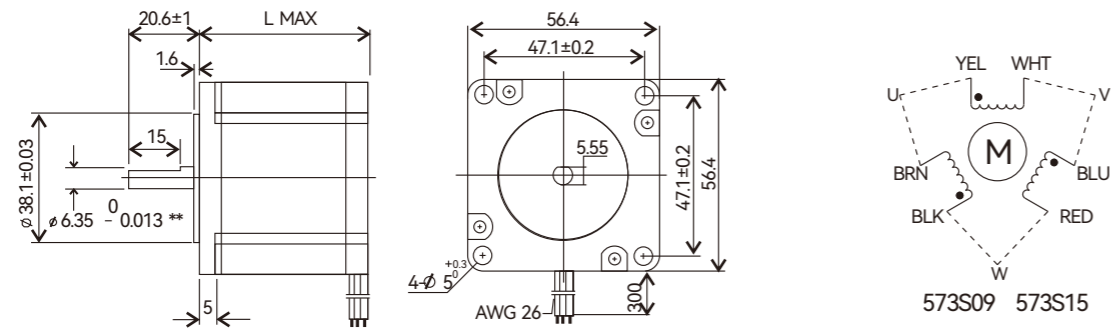

573S09 573S15

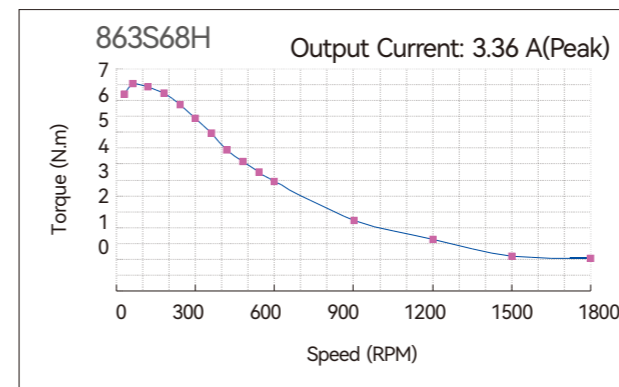
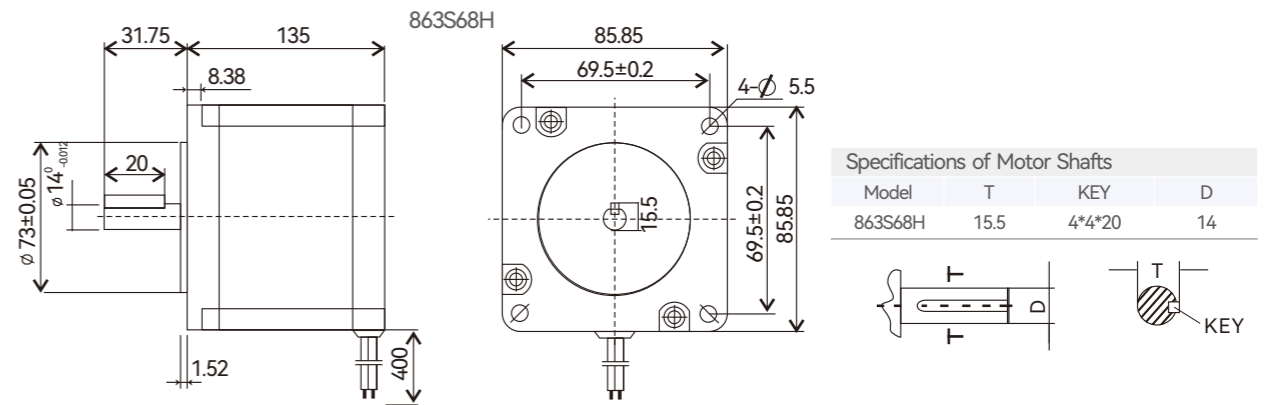
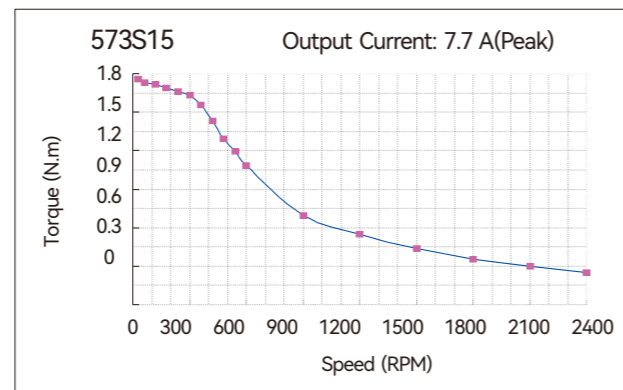
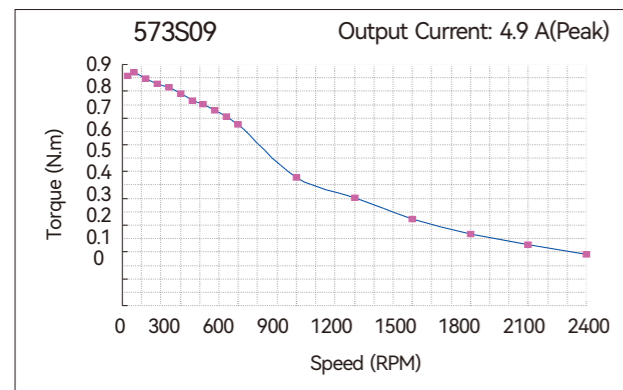
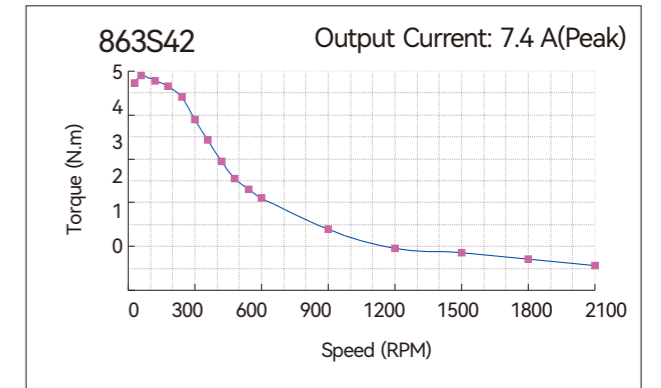
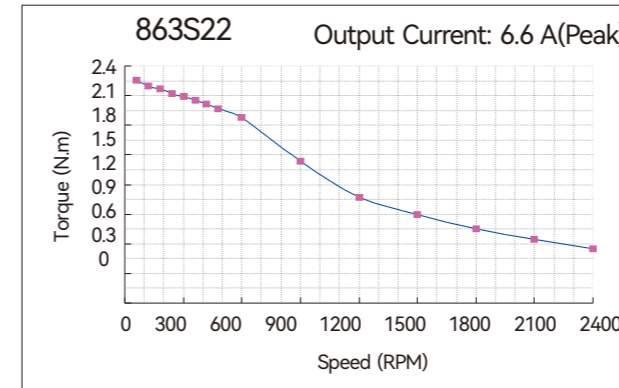

Closed Loop Stepper Products

Fieldbus Closed Loop Stepper Drives

2CS3EIP Series

- Support EtherNet/IP fieldbus
- Matching most of master controller
- No loss of step, Excellent performance



Closed Loop Stepper Product Part Numbers

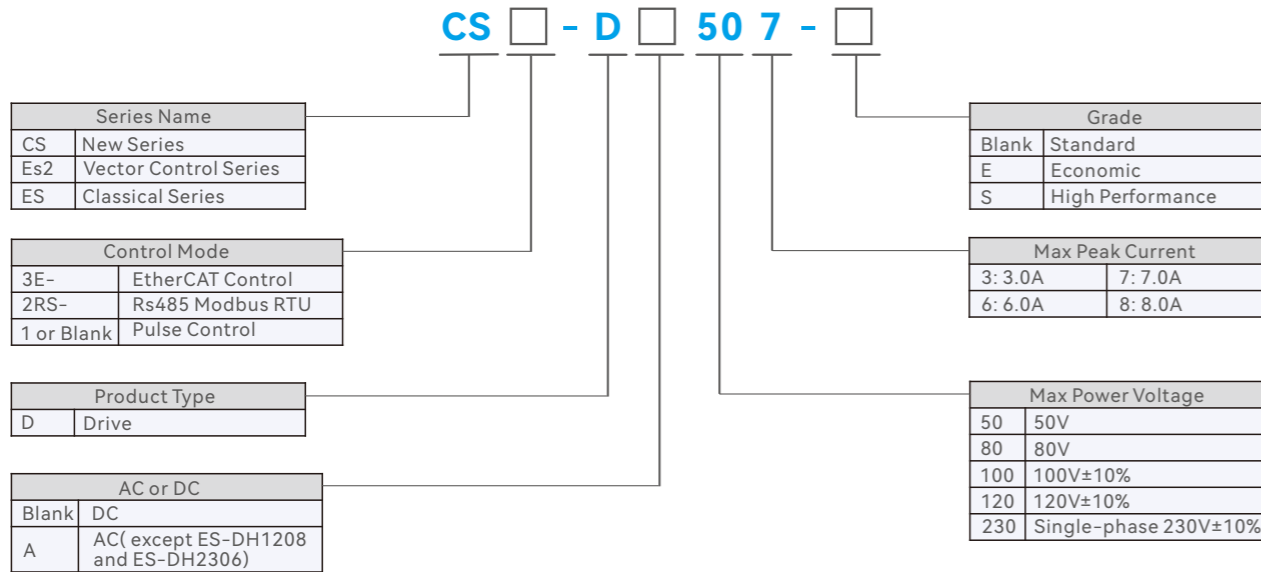

Closed Loop Stepper Motor

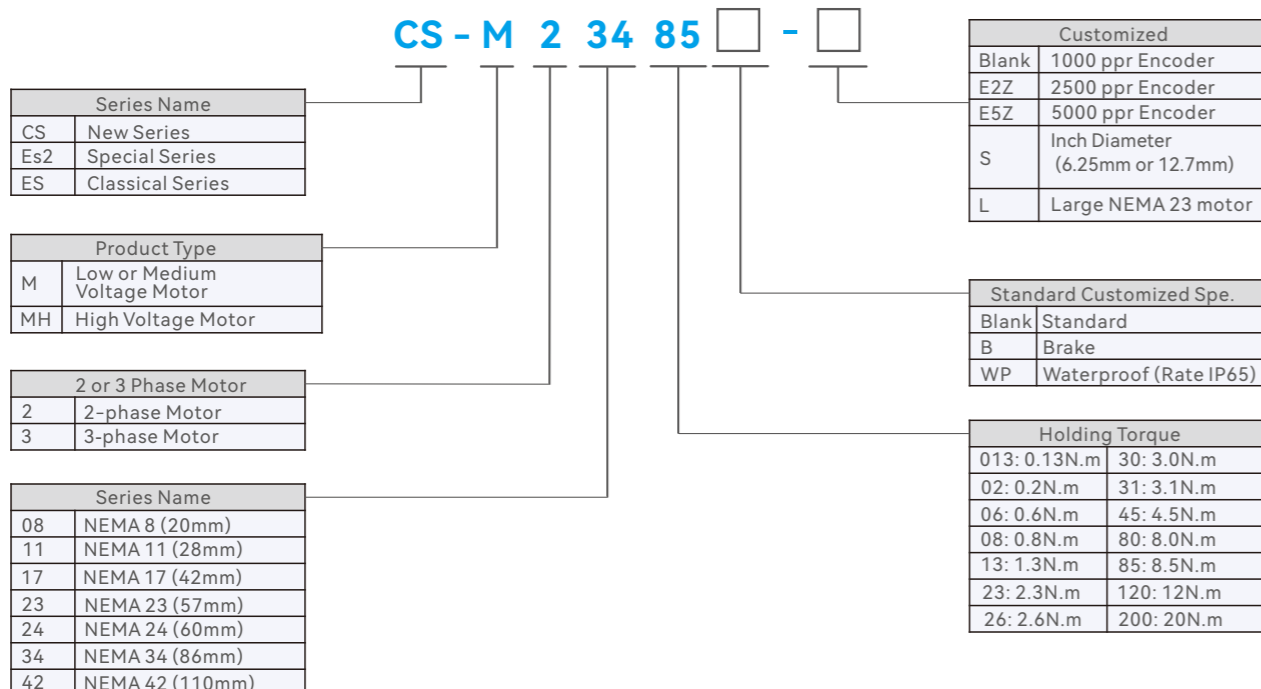

EtherNet/IP Communication

- Support EtherNet/IP communication.
- Support great majority of master station such as Beckhoff, Omron, KEYENCE, Panasonic etc.
- Support position, velocity, and homing control mode.

More Efficient by Dual-axis Control

- One drive controls two axes via one IP address, highly reduce communication load rate.
- Two axes are independently controlled.

STO Optional

- Safe torque off (STO) ensure the safety system.

Saving Mounting Space

- 10% thickness reducing compared to one single-axis drive.
- 50% at least mounting space saving compared to two single-axis drives.

Saving Cost

- One dual-axis drive is more economy than two single-axis drives.

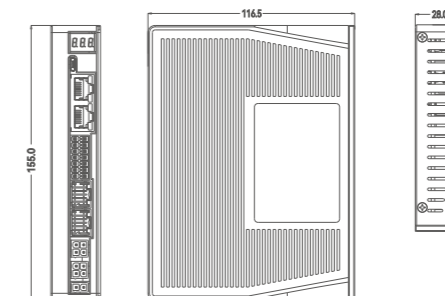

(Unit: mm)

Models	Operating Voltage	Output Current(A)	Matching Motor	Weight(kg)	Dimension(mm)
2CS3IPE-D503	20-50VDC	0.5-2.2	NEMA8/11/14/17	0.4	155*116.5*28
2CS3IPE-D507	20-50VDC	1.0-7.0	NEMA17/23/24	0.4	155*116.5*28
Terminal Resistance	The last node needs to add the terminal resistance generally				
CABLE-USB1M5	Tuning cable				
CABLE-TX*M*-BUS	Network Cable: 0.1m, 0.2m, 0.3m, 0.4m, 1m, 1.5m, 2m, 3m,5m,7m, 10m,15m, 20m				

Fieldbus Closed Loop Stepper Drives

2CS3E Series

- Support EtherCAT fieldbus
- Matching most of master controller



Fieldbus Closed Loop Stepper Drives

CS3E Series

- Support CoE control and CiA 402 protocol
- Matching most of master controller
- Conformance tested by ETG
- No loss of step, Excellent performance

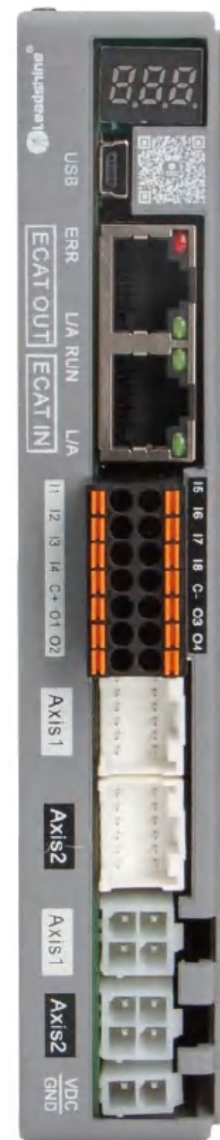

More Efficient by Dual-axis Control

- One drive controls two axes via one IP address, highly reduce communication load rate.
- Two axes are independently controlled.

EtherCAT Communication

- Support EtherCAT communication.
- Support great majority of master station such as Beckhoff, Omron, KEYENCE, Panasonic etc.
- Support position, velocity, and homing control mode.

STO Optional

- Safe torque off (STO) ensure the safety system.

Saving Mounting Space

- 10% thickness reducing compared to one single-axis drive.
- 50% at least mounting space saving compared to two single-axis drives.

Saving Cost

- One dual-axis drive is more economy than two single-axis drives.

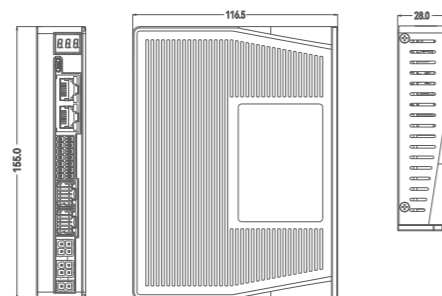

(Unit: mm)

Models	Operating Voltage	Output Current(A)	Matching Motor	Weight(kg)	Dimension(mm)
2CS3E-D503	20-50VDC	0.5-2.2	NEMA8/11/14/17	0.4	155*116.5*28
2CS3E-D507	20-50VDC	1.0-7.0	NEMA17/23/24	0.4	155*116.5*28
Terminal Resistance	The last node needs to add the terminal resistance generally				
CABLE-USB1M5	Tuning cable				
CABLE-TX*M*-BUS	Network Cable: 0.1m, 0.2m, 0.3m, 0.4m, 1m, 1.5m, 2m, 3m,5m,7m, 10m,15m, 20m				

Introduction

The CS3E series drives support operating modes: Cyclic Synchronous Position (CSP), Profile Position (PP), Profile Velocity (PV), Homing(HM). The products can be matched with most of EtherCAT controller/PLC such as Beckhoff, Omron, Trio, etc.

They have excellent performance including enhanced reliability, super-low noise, anti-resonance, low-speed ripple smoothing and remains 40% less cost than network servo at least. Can power 2-phase NEMA8,11, 14, 17, 23, 24 and 34 stepper motors with incremental encoder in many industrial applications such as CNC, medical, electronics, packaging...

Features

- No loss of step, No hunting, No torque reservation
- CS3E support standard EtherCAT protocol with operation modes of PP, PV, CSP, HM
- 7 configurable digital inputs, 7 optically isolated digital outputs include brake output
- USB port for parameters configuration
- Two 7-segment display velocity or slave ID or operation mode or error code
- Encoder resolution: 1000 / 5000 line for NEMA11/14/17/23/24/ 34 CS motors
- Protections for over-voltage, over-current and position following error, encoder wiring error, etc.
- Thickness reduce to 28mm, more benefit for mounting
- Friendly type-C tuning port
- Improve network anti-interference ability

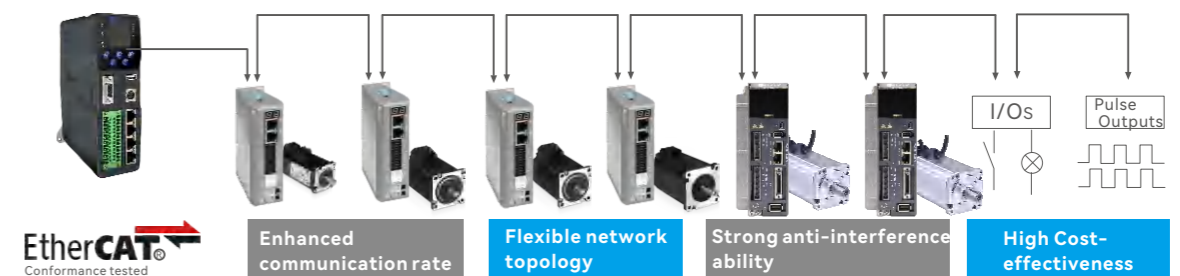

EtherCAT Master Controller or PLC

Models	Operating Voltage	Output Current(A)	Matching Motor	Weight(kg)	Dimension(mm)
CS3E-D503B	20-50VDC	0.1-3.0A	NEMA8/11/14/17	0.28	118*90*28
CS3E-D507B	20-50VDC	0.1-7.0A	NEMA17/23/24	0.28	118*90*28
CS3E-D1008	20-80VAC or 30-110VDC	0.5-8.0A	NEMA34	0.85	151*97*52
CABLE-TYPEC2M0	Tuning Cable				
CABLE-TX*M*-BUS	Network Cable: 0.1m, 0.2m, 0.3m, 0.4m, 1m, 1.5m, 2m, 3m,5m,7m, 10m,15m, 20m				
CABLEM-BM*M*	Encoder Extension Cable				
CABLEM-RZ*M*	Motor Extension Cable				

Fieldbus Closed Loop Stepper Drives

CS2RS Series



- Standard Isolated RS485 Modbus
- No loss of step & smooth motion
- Built-in Uni-axial Control Instruction
- HMI, PLC or External I/O start motion

Pulse Control Closed Loop Stepper Drives

CS1 Series---Enhanced Version

CS Series---Cost-effective Version



Features

7 Programmable Inputs

- Limit + / - or Origin inputs
- Quick stop, Alarm reset and Enable inputs
- JOG + / - or Position Table inputs

3 Programmable Outputs

- Alarm, Brake outputs
- Homing / Instruction / Path complete

Modes of Operation

- Velocity
- Position
- Homing

Support Functions

- Teaching
- Interrupt
- Skip, Suspend, Circulate motion

PC Software for Easy Setup, Fine Tune Matching Motors

- NEMA8, 11,17, 23, 24, 34
- Standard, dual shaft, brake, waterproof

1. Instruction smoothing

Adopted closed loop step system to make real-time position error correction ,can eliminate potential loss of step.

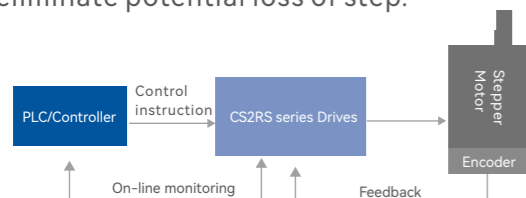

2.Support RS485 communication

Standard Modbus RTU protocol, RS485 communication can network up to 31 axes

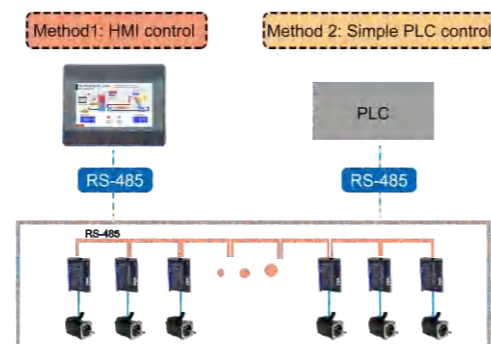

3.Built-in uni-axial control instruction

Programmable 16-segment position table, support positioning/homing/limit/quick stop/ JOG...

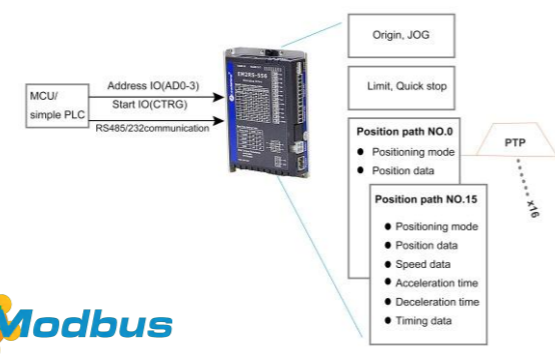

Models	Operating Voltage	Output Current(A)	Matching Motor	Weight(kg)	Dimension(mm)
CS2RS-D503	20-50VDC	0.5-3.0	NEMA8/11/14/17	0.38	116*69.2*26.5
CS2RS-D507	20-50VDC	0.5-7.0	NEMA17/23/24	0.38	116*69.2*26.5
CS2RS-D1008	20-80VAC or 30-100VDC	0.5-8.0	NEMA24/34	0.57	151*97*53
CABLE-PC-1	Tuning Cable				
CABLEM-BM*M*	Encoder Extension Cable				
CABLEM-RZ*M*	Motor Extension Cable				

CS1 Series----Enhanced Performance

Features

- New generation of algorithm
- 30% vibration improving than before
- 20db noise improving than before
- 20°C motor temperature rise improving than before

Switch Settings

- Microstep resolution
- Rotation direction
- Pulse Mode
- Positional command filter
- Closed / Open Loop Mode
- Encoder resolution
- Gain adjustment and output current
- 5V or 24V signal voltage optional

Inputs and Outputs

- Step & DIR (CW & CCW) inputs
- Enable input and Error Reset input
- Alarm output and In Position output
- Brake outputs
- Encoder A/B/Z outputs

Electrical Specifications

Items	CS1-D503S		CS1-D507S		CS1-D728S	
	Min	Max	Min	Max	Min	Max
Output Current (A)	0.5	3	0.5	7	0.5	8
Power Voltage (VDC)	20	50	20	50	20	72
Input Frequency (kHz)	-	500	-	500	-	500

Pin Assignments

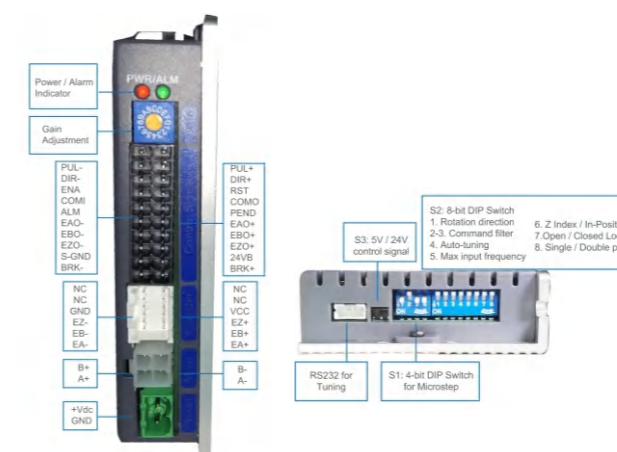



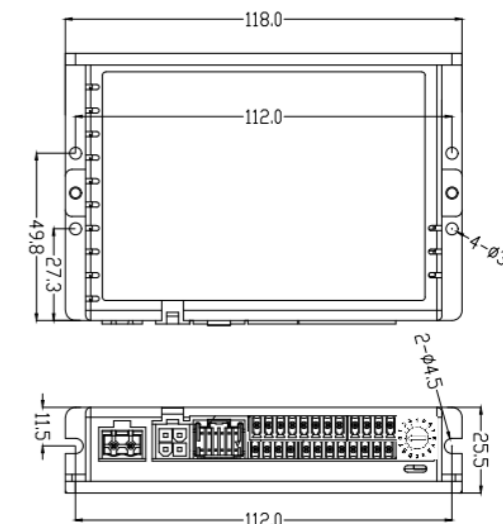

Dimensions



CS Series---Cost-effective Version

The CS series consists of ES seasy servo drives adopting Leadshine latest advanced closed loop control technology. Those drives are highly reliable with good performance and highly competitive cost. They can power a wide range of closed loop stepper motors from NEMA 8 to NEMA 34 (model dependent) with incremental encoders. CS series drives are easy to configure and setup.

Electrical Specifications

CS Series Drives				
Model			 NEW	 NEW
	CS-D508	CS-D808	CS-D507E	CS-D1008E
Operating Voltage	20-50VDC	20-80VDC	20-50VDC	20-80VAC or 30-110VDC
Peak Output Current	0.5-7.0A	0.5-8.0A	0.5-7.0A	0.5-8.0A
Control Signal Voltage	5V		5/24V	
Max. Input Frequency	200KHz (500kHz optional)			

Dimensions

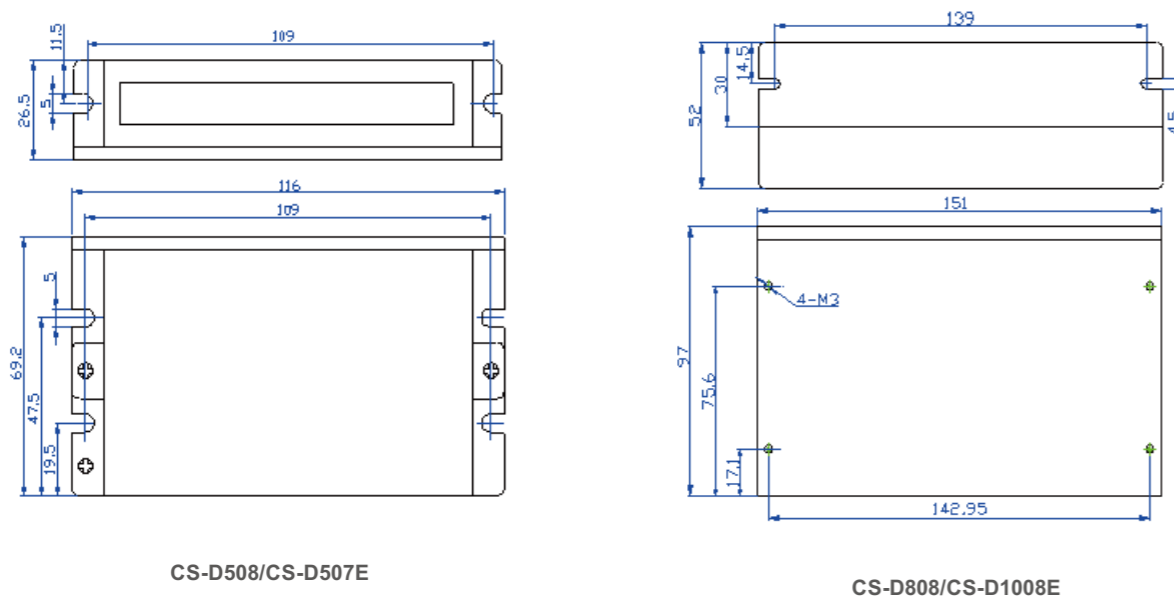

Closed Loop Stepper Motors CS-M Series



- Replace ES-M series easy servo motor
- Frame size of NEMA 8 to 34
- High reliability and high precision
- Reliable encoder solution

Introduction

CS-M series closed loop stepper motor integrated the cm series stepper motor and encoder, which can provide large torque, low heat and reliable position feedback signals. CS-M series also includes the types with brake, waterproof and different resolution. As a result of large-scale automated production lines and strict quality management system, CS-M series motors are more stable, reliable, superior, consistent and has a lower lost. **Most of ES-M easy servo motors will be replaced by CS-M motors.**

Encoder Specifications

Encoder Resolution	1000 ppr, 2500 ppr, 5000 ppr
Encoder Current	Typical 56mA /Max. 59mA
Low Level	0.4v@20mA Max
High Level	2.4v@-20mA Min

Motor Specifications

Step Angle	1.8°
Position Accuracy	±0.09°
Temp Rise(Max.)	Max. 85K
Operation Environment	Temperature: -10°C ~ +50°C; Humidity: Max. 85%
Insulation Class	B
Insulation Resistance	Min.100 MΩ, 500 V DC
Dielectric Strength	500 VAC, 1 min
Radial Play	0.025 mm Max. (Load 5N)
Axial Play	0.075 mm Max. (Load 10N)

Installation & Operation Conditions

Motor Size	NEMA17	NEMA23	NEMA24	NEMA34
Store Temperature	-10°C ~ +50°C			
Store Humidity	85% Max.			
Operation Environment	Non-corrosive gas and dust; No direct contact with water, oil (except the waterproof type)			
Radial Load(N) (Distance to the flange 10mm)	30	75	90	300
Axial Load(N)	Less than motor weight			

Closed Loop Stepper Motors

- Below matched drives are Pulse Control type, EtherCAT and Modbus RS485 types are also available;
- 3-phase high voltage closed loop stepper motors are ES2-MH series, others are CS-M series;
- Maximum speed up to 3000 rpm, but depends on power voltage, current and load.

Phase/Series	Frame Size	Length(mm)	Model	Holding Torque(N.m)	Matching Drives	Remark
2-phase/CS-M	NEMA 17	56	CS-M21702	0.2	CS-D507E/CS1-D507S	
		63	CS-M21704	0.4	CS-D507E/CS1-D507S	This motor is not recommended
		70	CS-M21706	0.6	CS-D507E/CS1-D507S	
		83	CS-M21708	0.8	CS-D507E/CS1-D507S	
	NEMA 23	60	CS-M22306	0.6	CS-D507E/CS1-D507S	
		75	CS-M22313	1.3	CS-D507E/CS1-D507S	Replace ES-M22310
		109	CS-M22313B	1.3	CS-D507E/CS1-D507S	Motor with brake
		94	CS-M22313WP	1.3	CS-D507E/CS1-D507S	Motor with waterproof
		95	CS-M22323	2.3	CS-D507E/CS1-D507S	Replace ES-M22320
		131	CS-M22323B	2.3	CS-D507E/CS1-D507S	Motor with brake
		115	CS-M22323WP	2.3	CS-D507E/CS1-D507S	Motor with waterproof
		103	CS-M22326	2.6	CS-D507E/CS1-D507S	
	NEMA 24	86	CS-M22321-L	2.1	CS-D507E/CS1-D507S	NEMA23 motor with large body
		105	CS-M22331-L	3.1	CS-D507E/CS1-D507S	NEMA23 motor with large body
		89	CS-M22422	2.2	CS-D507E/CS1-D507S	
		129	CS-M22422B	2.2	CS-D507E/CS1-D507S	Motor with brake
		113	CS-M22422WP	2.2	CS-D507E/CS1-D507S	Motor with waterproof
		107	CS-M22430	3.0	CS-D507E/CS1-D507S	
		143	CS-M22430B	3.0	CS-D507E/CS1-D507S	Motor with brake
		130	CS-M22430WP	3.0	CS-D507E/CS1-D507S	Motor with waterproof
	NEMA 34	95	CS-M23435	3.5	CS-D1008E	
		109	CS-M23445	4.5	CS-D1008E	
		144	CS-M23445B	4.5	CS-D1008E	Motor with brake
		115	CS-M23445WP	4.5	CS-D1008E	Motor with waterproof
		127	CS-M23480	8.0	CS-D1008E	
		152	CS-M23480B	8.0	CS-D1008E	Motor with brake
		133	CS-M23480WP	8.0	CS-D1008E	Motor with waterproof
		147	CS-M23485	8.5	CS-D1008E	
182		CS-M23485B	8.5	CS-D1008E	Motor with brake	
153		CS-M23485WP	8.5	CS-D1008E	Motor with waterproof	
158		CS-M234120	12	CS-D1008E		
193		CS-M234120B	12	CS-D1008E	Motor with brake	
164	CS-M234120WP	12	CS-D1008E	Motor with waterproof		

Note: Contact Leadshine for Gearboxes and Encoder information.

Phase/Series	Frame Size	Length(mm)	Model	Holding Torque(N.m)	Matching Drives	Remark
3-phase/ES2-MH	NEMA 34	157	ES2-MH33480	8.0	ES-DH2306	
		190	ES2-MH33480B	8.0	ES-DH2306	Motor with brake
		162	ES2-MH33480WP	8.0	ES-DH2306	Motor with waterproof
		184	ES2-MH334100	10	ES-DH2306	
		218	ES2-MH334100B	10	ES-DH2306	Motor with brake
		191	ES2-MH334100WP	10	ES-DH2306	Motor with waterproof
	NEMA 42	162	ES2-MH342120	12	ES-DH2306	
		207	ES2-MH342120B	12	ES-DH2306	Motor with brake
		167	ES2-MH342120WP	12	ES-DH2306	Motor with waterproof
		244	ES2-MH342200	20	ES-DH2306	

Phase/Series	Frame Size	Length(mm)	Model	Holding Torque(N.m)	Matching Drives	Remark
2-phase/CS-M	NEMA 8	51	CS-M208003	0.03	CS-D507E	-
	NEMA 11	62	CS-M211013	0.13	CS-D507E	-
	NEMA 17	93	CS-M21704B	0.4	CS-D507E	Brake
		101	CS-M21706B	0.6	CS-D507E	Brake
		113	CS-M21708B	0.8	CS-D507E	Brake
	NEMA 23	96	CS-M22323-S	2.3	CS-D507E	1/4-inch shaft diameter
		96	CS-M22323-E5Z	2.3	CS-D507E	5000-line
		104	CS-M22326-S	2.6	CS-D507E	1/4-inch shaft diameter
		105	CS-M22331-L-S	3.1	CS-D507E	3/8-inch shaft diameter
		107	CS-M22430-I14	3.0	CS-D507E	AC servo flange
	NEMA 24	147	CS-M22430B-I14	3.0	CS-D507E	AC servo flange, Brake
		107	CS-M22430-E5Z	3.0	CS-D507E	5000-line
		143	CS-M22430B-E5Z	3.0	CS-D507E	Brake, 5000-line
		109	CS-M22445-S	4.5	CS-D1008E	1/2-inch shaft diameter
	NEMA 34	109	CS-M22445-E5Z	4.5	CS-D1008E	5000-line
		135	CS-M22445B-E5Z	4.5	CS-D1008E	Brake, 5000-line
		127	CS-M23480-S	8.0	CS-D1008E	1/2-inch shaft diameter
		127	CS-M23480-E5Z	8.0	CS-D1008E	5000-line
		147	CS-M23485-S	8.5	CS-D1008E	1/2-inch shaft diameter
		147	CS-M23485-E5Z	8.5	CS-D1008E	5000-line
		172	CS-M23485B-E5Z	8.5	CS-D1008E	Brake, 5000-line
		158	CS-M234120-E5Z	12	CS-D1008E	5000-line
		184	CS-M234120B-E5Z	12	CS-D1008E	Brake, 5000-line

NEMA 17 (42mm)



Standard Model:

Model	Length (mm)	Holding Torque(N·m)	Rated Current (A)	Inertia (10 ⁻⁴ kgm ²)
CS-M21702	56	0.2	1.5	0.023
CS-M21704	63	0.4	1.5	0.045
CS-M21706	70	0.6	2.5	0.077
CS-M21708	83	0.8	2.5	0.11

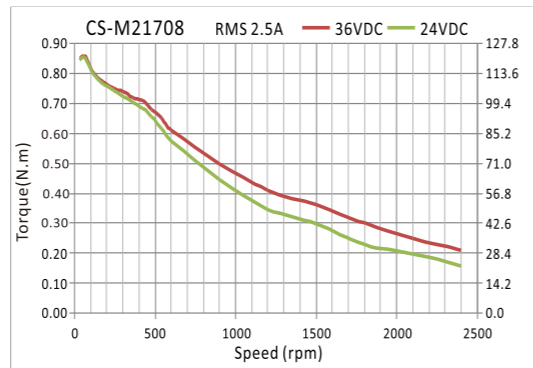
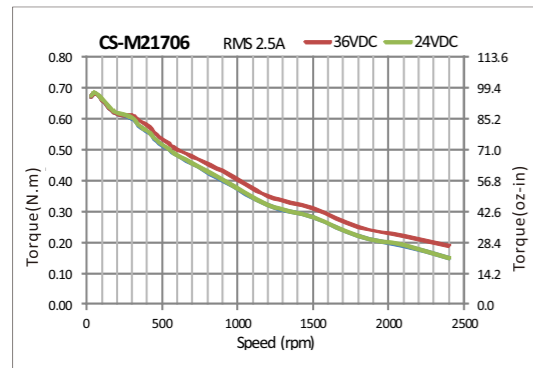
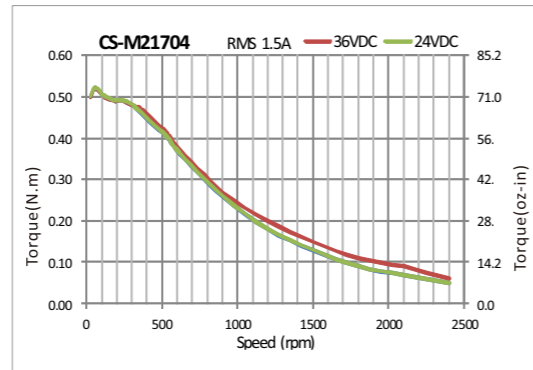
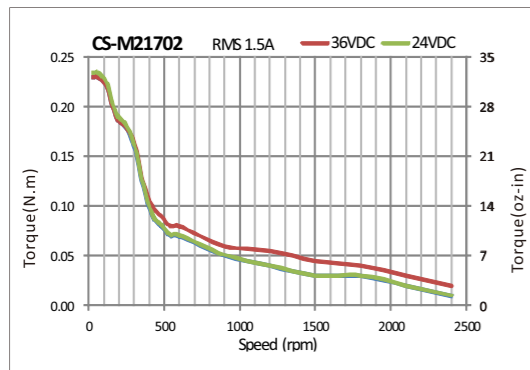
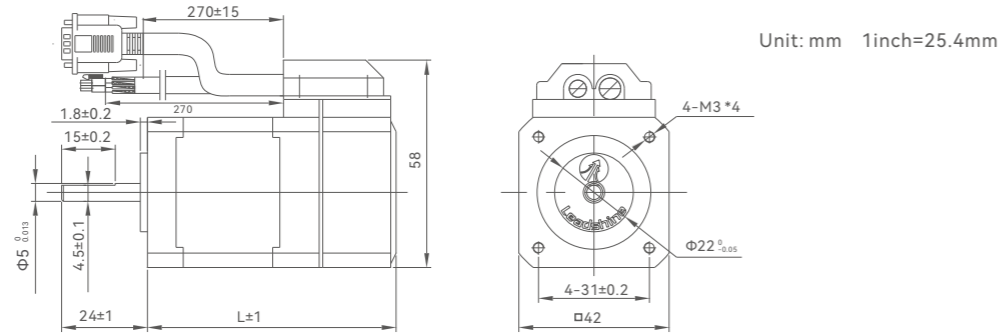

NEMA 23 (57mm)



Standard Model:

Model	Length (mm)	Holding Torque(N·m)	Rated Current (A)	Inertia (10 ⁻⁴ kgm ²)
CS-M22306	60	0.6	3.0	0.131
CS-M22313	75	1.3	4.0	0.3
CS-M22323	95	2.3	5.0	0.48
CS-M22326	103	2.6	5.0	0.7

Note: Motors with 1/4 in(6.35mm) shaft diameter are available.

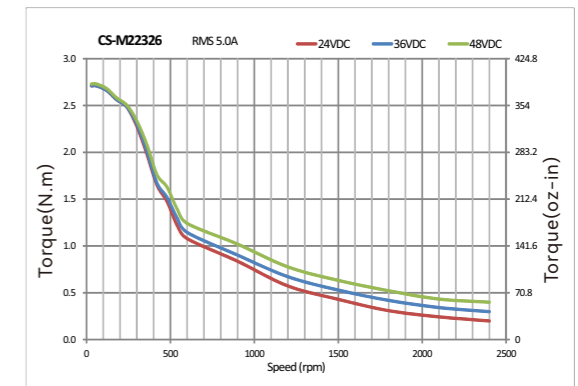
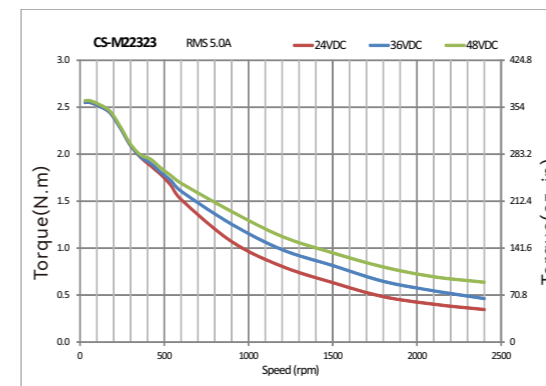
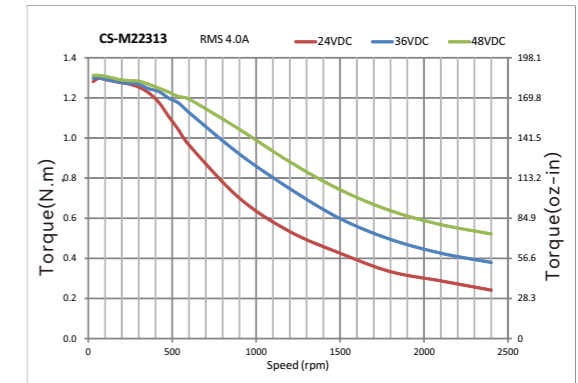
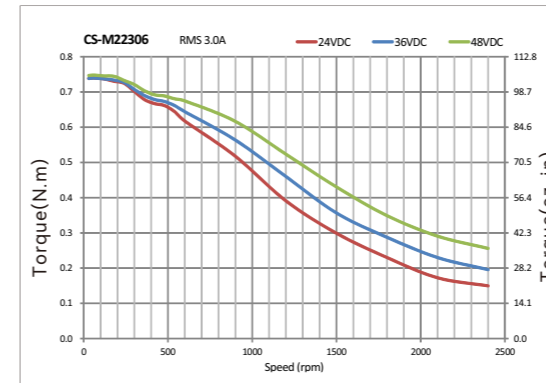
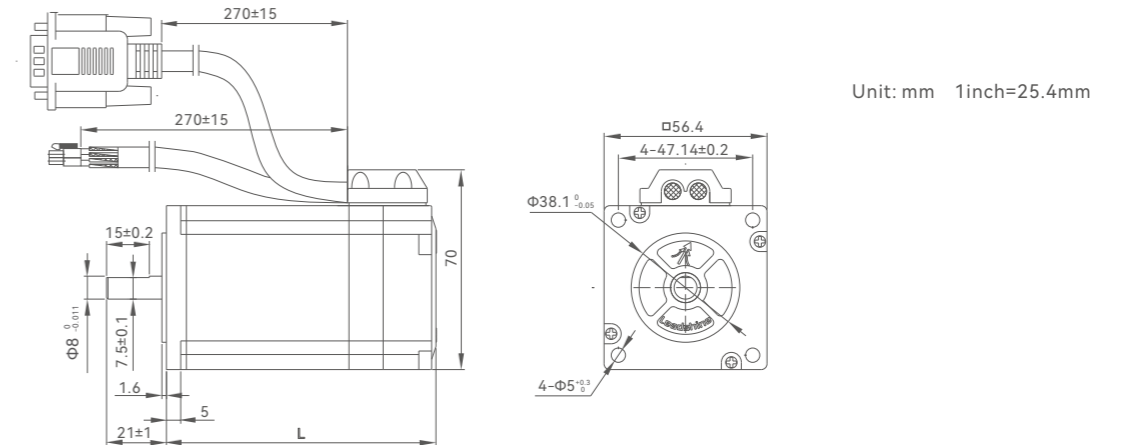

NEMA 23 (57mm)



Standard Model:

Model	Length (mm)	Holding Torque(N·m)	Rated Current (A)	Inertia (10 ⁻⁴ kgm ²)
CS-M22321-L	86	2.1	5.0	0.49
CS-M22331-L	105	3.1	5.0	0.69

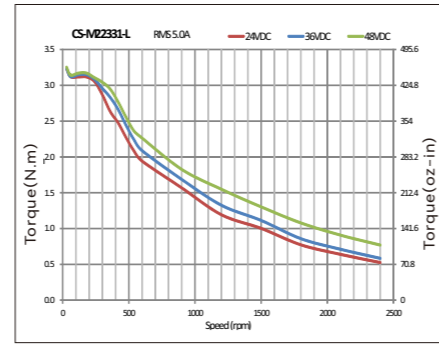
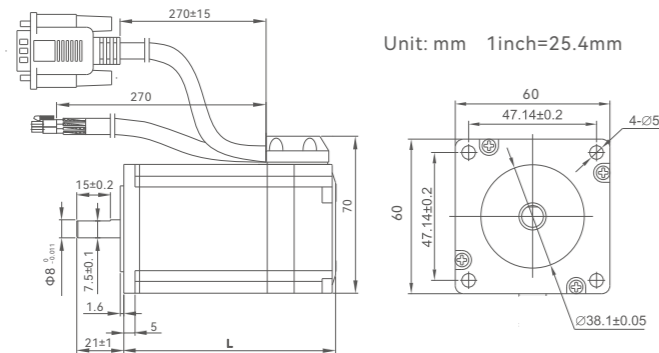

NEMA 23 (57mm)



Standard Model:

Model	Length (mm)	Holding Torque (N·m)	Rated Current (A)	Inertia (10 ⁻⁴ kgm ²)
CS-M23435	95	3.5	4.0	1.0
CS-M23445	109	4.5	6.0	1.95
CS-M23480	127	8.0	6.0	2.5
CS-M23485	147	8.5	6.0	2.8
CS-M234120	158	12.0	6.0	3.0

Note: Motors with 1/2 in(12.7mm) shaft diameter are available.

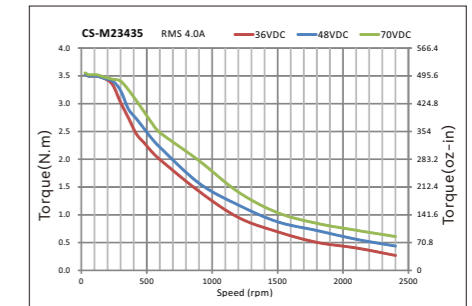
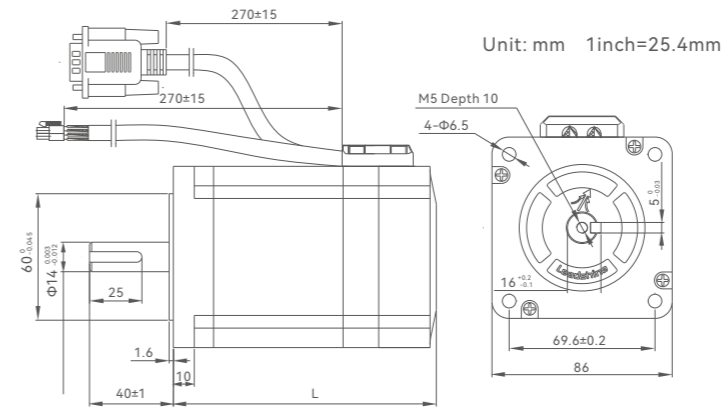

NEMA 24 (60mm)



Standard Model:

Model	Length (mm)	Holding Torque(N·m)	Rated Current (A)	Inertia (10 ⁻⁴ kgm ²)
CS-M22422	86	2.2	5.0	0.49
CS-M22430	103	3.0	5.0	0.69

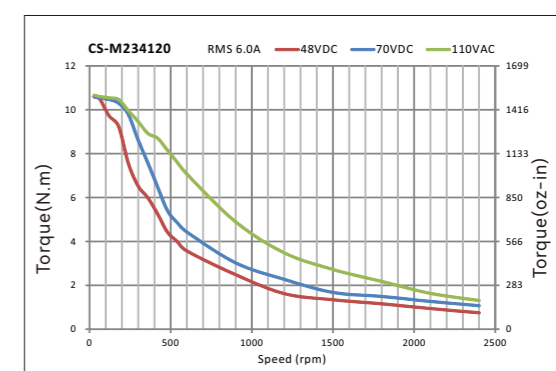
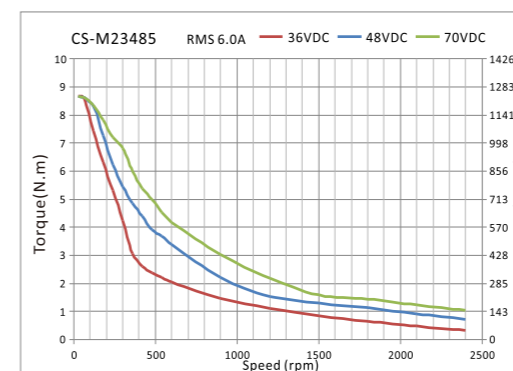
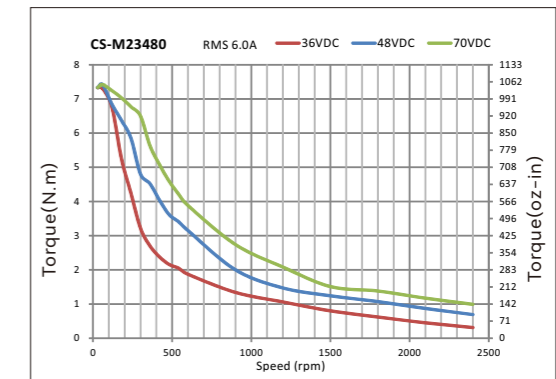
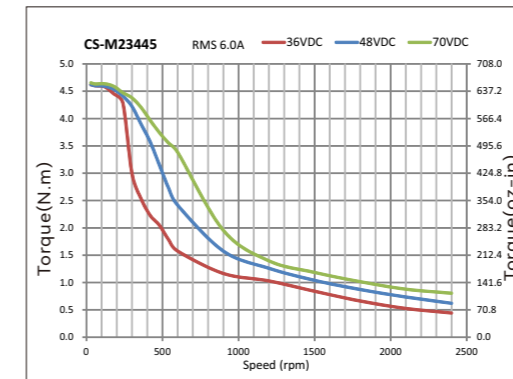
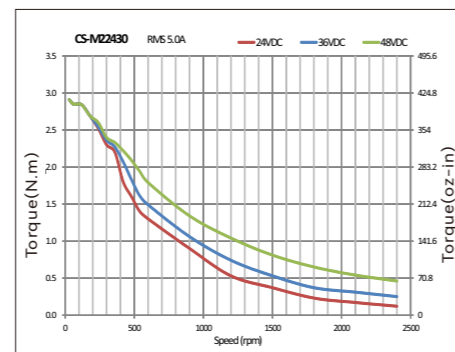
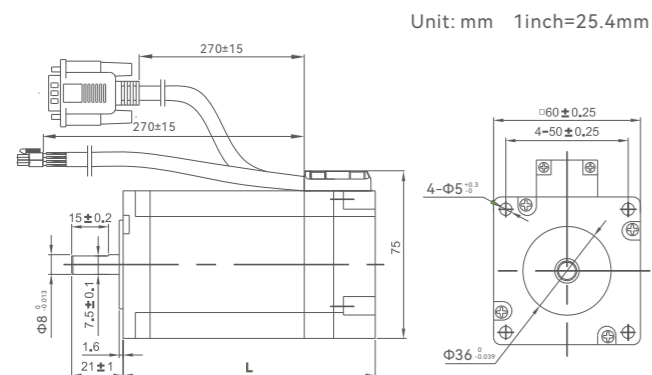

3-phase: NEMA 34, 42



Standard Model:

Model	Length (mm)	Holding Torque (N·m)	Rated Current (A)	Inertia (10 ⁻⁴ kgm ²)
ES2-MH33480	158	8.0	6.0	3.0
ES2-MH334100	185	10.0	6.0	3.0
ES2-MH342120	162	12.0	4.2	10.8
ES2-MH342200	244	20.0	5.2	17

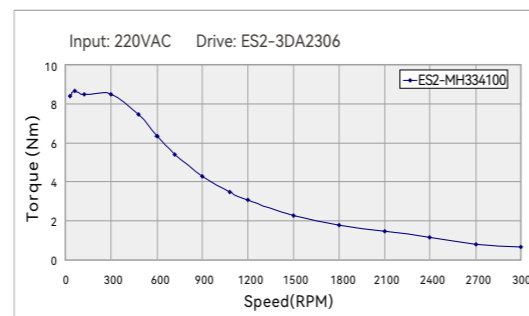
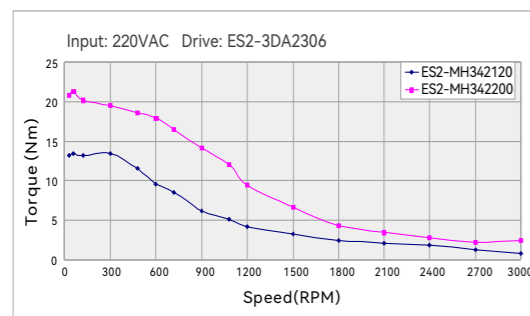
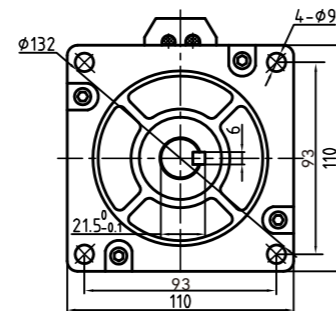
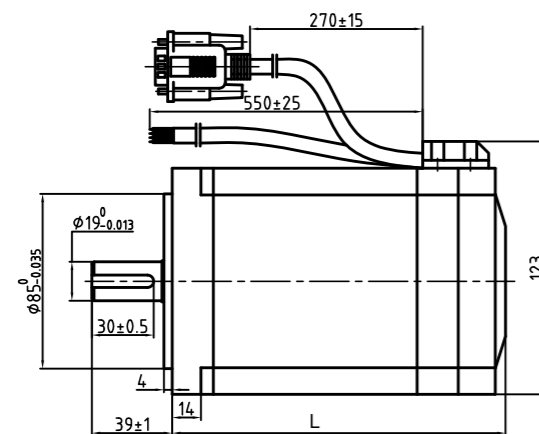
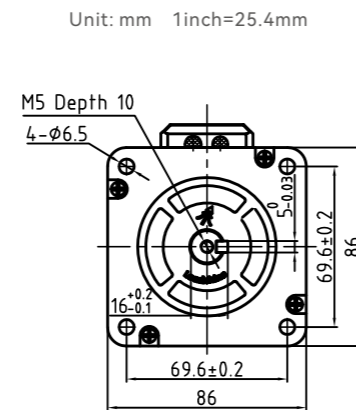
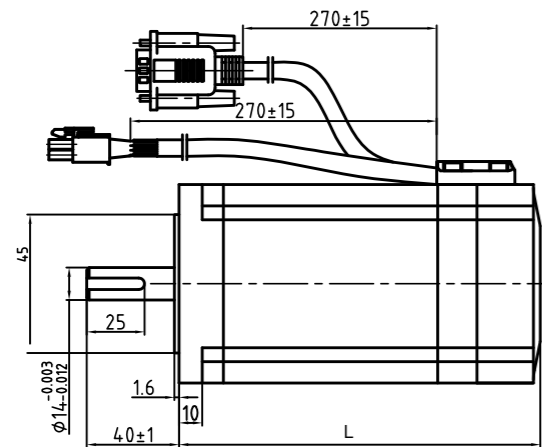

Integrated Stepper Motors iEM & iCS Series

- Replace iST and iES integrated motor
- Motor Frame: NEMA17,23,24
- Enhanced compact design
- Smoother, No hunting



Introduction

- iEM series is integrated open-loop stepper motor with Leadshine's latest digital stepper technology.
- iCS series is integrated closed-loop stepper motor with 14-bit single-turn absolute encoder for smooth and jitter-free motor start-up.
- iEM and iCS series motors output torque can up to 3.5Nm and supports Modbus RS485 communication with Indexer control function. And with a more compact design, it is especially suitable for applications with strict mounting space requirements, and it is easy to use, which can further reduce customers' procurement and labor costs.



Introduction

Encoder Type	Single-turn absolute magnetic encoder
Encoder Resolution	14-bit
Angle Calibration	Be sure to calibrate after encoder installation

Introduction

Step Angle	1.8°		
Position Accuracy	±0.09°		
Max Temperature	95° C		
Operation Environment	Temperature: -10° C ~ 50° C; Humidity: 85%RH Max		
IP Rate	IP20		
Radial Load (N) (Distance to the flange 10mm)	NEMA17	NEMA23	NEMA24
	30	75	90
Axial Load (N)	Less than motor weight		

Integrated Stepper Motor Overview

Models	Type & Frame	Operating Voltage (VDC)	Control Mode	Holding Torque (N.m)	Logical Voltage (VDC)	Motor Length (mm)
iEM-1703	Open Loop NEMA17	20-36	Pulse&Dir	0.3	5	64
iEM-1706		20-36		0.6	5	72
iEM-1708		20-36		0.8	5	85
iEM-RS1706		RS485 Modbus	20-36	0.6	12-24	73
iEM-RS1708			20-36	0.8	12-24	86
iEM-2313	Open Loop NEMA23	20-50	Pulse&Dir, CW&CCW	1.3	5	75
iEM-2323		20-50		2.3	5	96
iEM-2321-L		20-50		2.1	5	89
iEM-2331-L		20-50	3.1	5	109	
iEM-RS2313		RS485 Modbus	20-50	1.3	12-24	78
iEM-RS2323			20-50	2.3	12-24	99
iEM-2430	Open Loop NEMA24	20-50	Pulse&Dir, CW&CCW	3.0	5	109
iEM-2435		20-50		3.5	5	122
iCS-1703	Closed Loop NEMA17	20-36	Pulse&Dir	0.3	5	64
iCS-1706		20-36		0.6	5	72
iCS-1708		20-36		0.8	5	85
iCS-RS1706		RS485 Modbus	20-36	0.6	12-24	73
iCS-RS1708			20-36	0.8	12-24	86
iCS-2313	Closed Loop NEMA23	20-50	Pulse&Dir, CW&CCW	1.3	5	75
iCS-2323		20-50		2.3	5	96
iCS-2321-L		20-50		2.1	5	89
iCS-2331-L		20-50	3.1	5	109	
iCS-RS2313		RS485 Modbus	20-50	1.3	12-24	78
iCS-RS2323			20-50	2.3	12-24	99
iCS-2430	Closed Loop NEMA24	20-50	Pulse&Dir, CW&CCW	3.0	5	109
iCS-2435		20-50		3.5	5	122

iEM & iCS Interface



Port	Description
DIP Switches	SW1-SW4: Microstep SW5: Motor Direction SW6: PUL&DIR and CW&CCW selection SW7: Smoothing filtering time SW8: Activated pulse edge for iEM series Open/closed loop control selection for iCS series
I/O Port	PUL+/-, DIR+/-, ENA+/-, ALM+/-

Dimensions

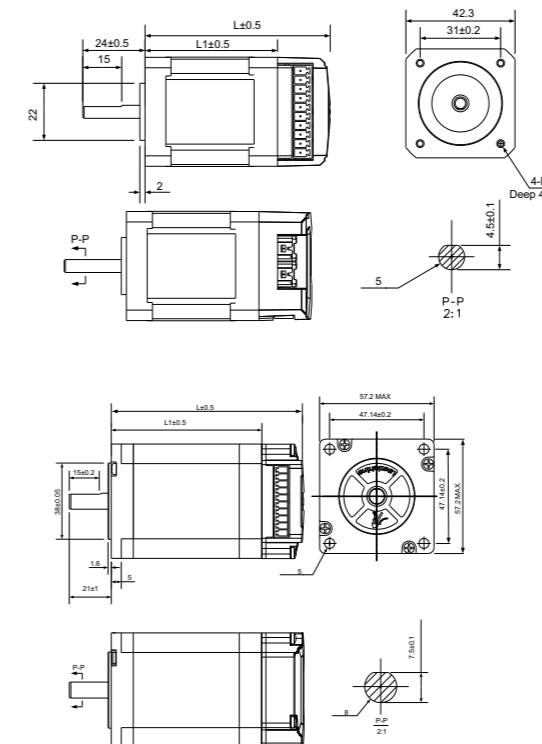

Unit: mm 1inch=25.4mm

Model	L1 length	L length
iCS-1703	43	64
iCS-1706	51	72
iCS-1708	64	85

Model	L1 length	L length
iCS-2113	43	64
iCS-2323	51	72
iCS-2321-L	64	85
iCS-2331-L	88	109
iCS-2430	88	109
iCS-2435	101	122

Tuning Cable & Software

Cable Model	CABLE-PC-1
Software Name	StandardProTuner

iEM-RS & iCS-RS Interface

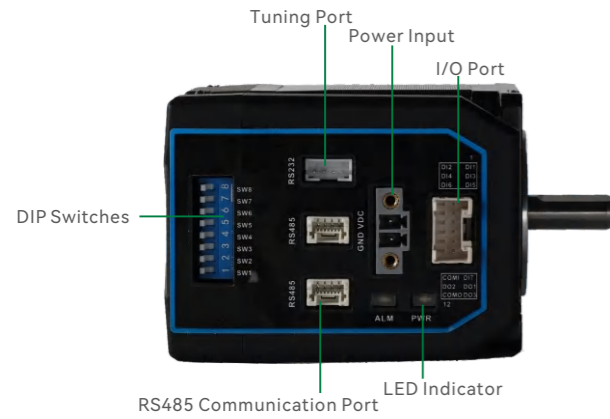

Port	Description
DIP Switches	SW1-SW5: Node ID SW6-SW7: Baud Rate SW8: 120Ω Terminal Resistance
I/O Port	7 digital inputs, 3 digital outputs

Dimensions

Unit: mm 1inch=25.4mm

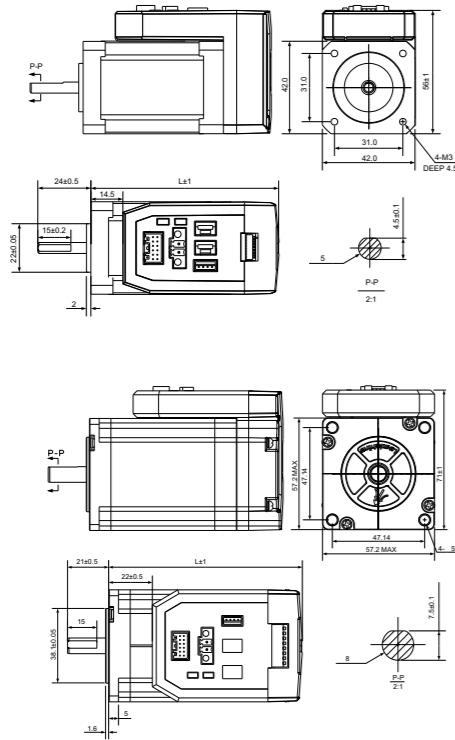

Model	L1 length
iCS-RS1706	73mm
iCS-RS1708	86mm

Model	L1 length
iCS-RS2313	78mm
iCS-RS2323	99mm

Tuning Cable & Software

Cable Model	CABLE-PC-1
Software Name	StandardProTuner

Power Supplies

260W: 24VDC output

360W: 24VDC/36VDC/48VDC output

400W: 60VDC output



LSP Series----Power Supplies

Features

- 1.8 times overload
- Compact Size, Light in Weight
- Use Switch to select input voltage 220VAC ± 10% or 110 VAC ± 10%
- Over-current, Over-voltage, Low-voltage Protections
- Big Power with High Efficiency
- CE and RoHS

Electrical Specifications

Model	Output Voltage (VDC)	Continuous Current(A)	Peak Current(A)	Input Voltage	Power (W)	Dimensions (mm)	Weight (kg)
LSP-260-24	24	10.8	19.4	220VAC ± 10% or 110 VAC ± 10%	260	199*110*50	0.8
LSP-360-24	24	15	27		360	199*110*50	0.8
LSP-360-36	36	10	18		360	215*115*30	0.7
LSP-360-48	48	7.5	13.5		360	215*115*30	0.7
LSP-400-60	60	6.7	12		400	215*115*30	0.7

Dimensions

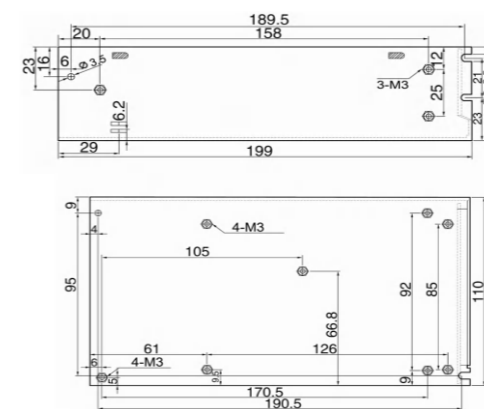

LSP-260-24, LSP-360-24

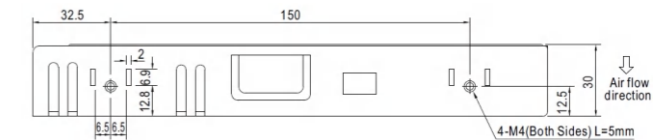

LSP-360-36, LSP-360-48, LSP-400-60

Gearboxes

Straight tooth planetary Gearbox
 Matched 23, 24, 34 stepper motors
 Gear ratio 3:1, 5:1, 7:1, 10:1 are available

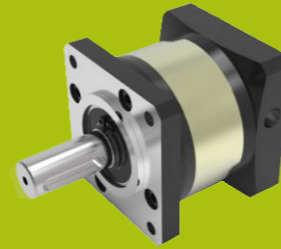

Specifications

Size	60mm				90mm			
Gear Ratio	3	5	7	10	3	5	7	10
Rated Output Torque (Nm)	16.5	29.5	19.5	8.5	60	94	64	40
Max Output Torque(Nm)	33.0	59.0	39.0	17.0	120	188	128	80
Rotation Inertial(10⁻⁴kgm²)	0.107	0.092	0.091	0.091	0.4	0.291	0.285	0.283
Rated Input Rotation Speed (RPM)	4000				3500			
Maximum Input Rotation Speed (RPM)	8000				6000			
Maximum Radial Force (N)	485				1020			
Maximum Axial Force (N)	380				850			
Free-load torque (N.m)	0.6				0.8			
Full-load Efficiency	96%				96%			
Backlash (arcmin)	<12				<12			
Noise (dB)	≤58				≤62			
Weight (kg)	1.0				2.8			
Torsional Rigidity	2.3				7.5			
Average Life (h)	>20000							
Lubricant	Long-term Lubrication							
Rotation Direction	Input and output in the same direction							
Protection Class	IP65							
Installation Way	Arbitrariness							

Model	Gear Ratio	Matched Motors
PLF060-3-P2-BJ-6.35-38.1	3:1	NEMA 23 Stepper Motor with 6.35mm Shaft Diameter
PLF060-5-P2-BJ-6.35-38.1	5:1	
PLF060-7-P2-BJ-6.35-38.1	7:1	
PLF060-10-P2-BJ-6.35-38.1	10:1	
PLF060-3-P2-BJ-8-38.1	3:1	NEMA 23 Stepper Motor with 8mm Shaft Diameter
PLF060-5-P2-BJ-8-38.1	5:1	
PLF060-7-P2-BJ-8-38.1	7:1	
PLF060-10-P2-BJ-8-38.1	10:1	
PLF090-3-P2-BJ-12.7-73	3:1	NEMA 34 Stepper Motor with 12.7mm Shaft Diameter
PLF090-5-P2-BJ-12.7-73	5:1	
PLF090-7-P2-BJ-12.7-73	7:1	
PLF090-10-P2-BJ-12.7-73	10:1	
PLF090-3-P2-BJ-14-73	3:1	NEMA 34 Stepper Motor with 14mm Shaft Diameter
PLF090-5-P2-BJ-14-73	5:1	
PLF090-7-P2-BJ-14-73	7:1	
PLF090-10-P2-BJ-14-73	10:1	
PLF090-3-P2-BJ-14-60	3:1	NEMA 34 Closed Loop Stepper Motor with 14mm Shaft Diameter
PLF090-5-P2-BJ-14-60	5:1	
PLF090-7-P2-BJ-14-60	7:1	
PLF090-10-P2-BJ-14-60	10:1	