



# CS

Reliable Low Cost  
Closed-loop Stepper System

## Leadshine Technology Co., Ltd.

Website: [www.leadshine.com](http://www.leadshine.com)

### Service:

Tel: 86-755-2641-8774 (for Asia, Australia, Africa region)

86-755-8654-2465 (for Europe region)

86-755-2665-5136 (for America region)

86-755-2641-0546

Email: [tech@leadshine.com](mailto:tech@leadshine.com)

### Sales Hot Line:

Tel: 86-755-2641-7674 (for Asia, Australia, Africa region)

86-755-2640-9254 (for Europe region)

86-755-2641-7617 (for America region)

Email: [sales@leadshine.com](mailto:sales@leadshine.com)

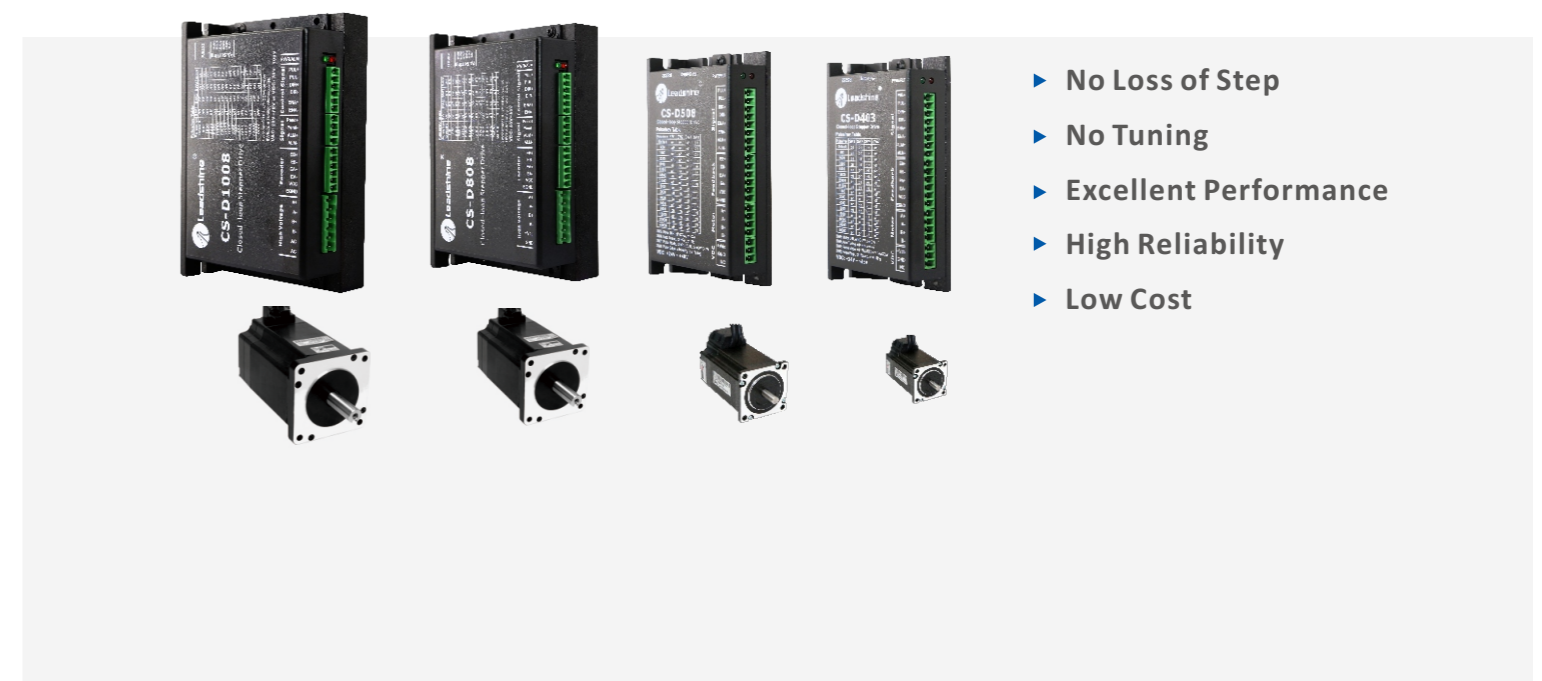

## Challenge for Choosing Open-loop Stepper Systems



- Potential risk of step loss & no real-time position error correction for open-loop stepper system
- Complexity & high cost to upgrade to servo system
- No existing low-cost solution combining features of both open-loop stepper and servo control system

## CS Series Advantages

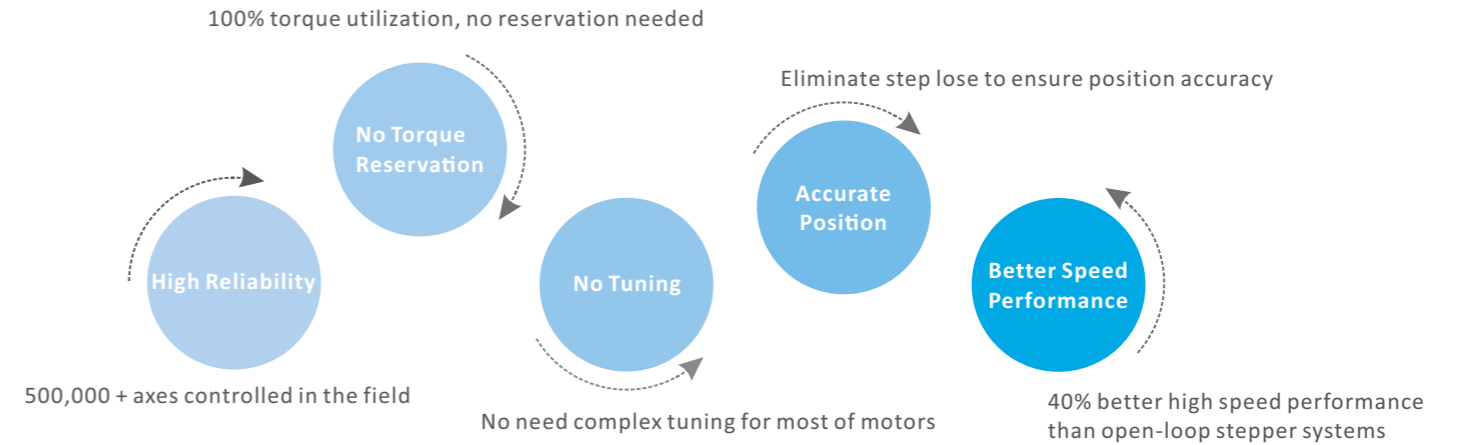

## Leadshine's Solution — Low-Cost CS Series Closed-loop Stepper Systems

To solve the challenge of open-loop stepper systems depicted in the above figure, Leadshine has released the CS series closed-loop stepper system. After adding an encoder to a stepper motor, a CS series closed-loop stepper drive can detect both the commanded target position & real-time position of the motor shaft and thus capable of closing the position loop like servo system. This approach makes the CS series closed-loop system not only solve the step loss problem of open-loop stepper systems, but also keep the simplicity and low cost features of open-loop systems. Therefore, Leadshine CS series is an ideal choice to adopt in new control systems, upgrade existing open-loop systems, and replace many servo applications. While the CS series can provide high performance you expect, it will also meet your low-cost requirement.

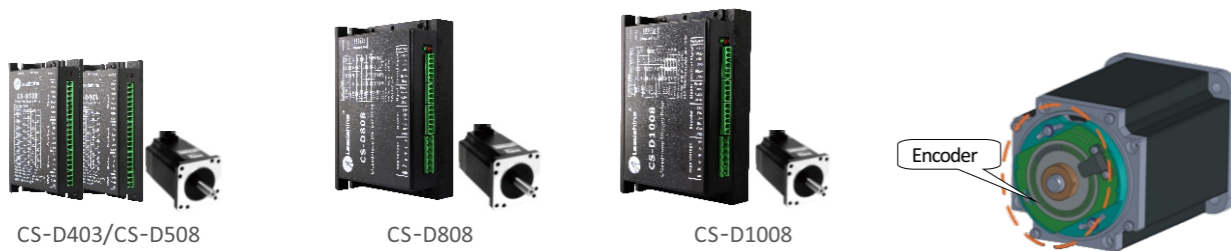

## Customer Benefits

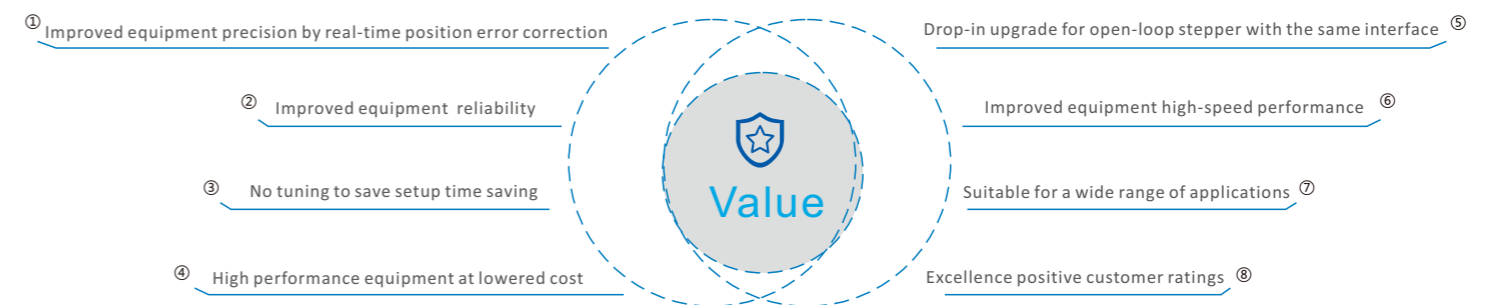

## Contents

1. CS Series Overview
2. CS Series Drives
3. CS Series Motors
4. Cables and Power Supplies
5. Ordering Information

# 01 CS Series Overview

## Advantages Over Open-loop Stepper Systems

- 100% torque utilization, and no 40-50% torque reservation
- Up to 30% lower motor heating at the same working condition
- Smoother motion and lower motor noise
- Less power consumption for longer motor lifetime

## 1.1 Features

### 1 Closed Position Loop to Eliminate Step Lose

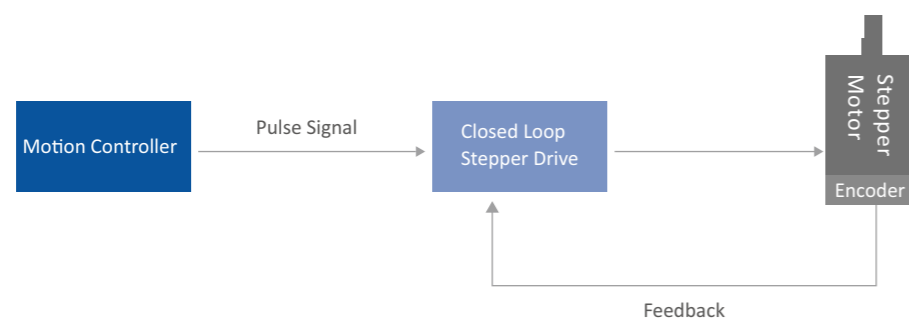

### 2 Reduced Motor Heating for Longer Motor Life Time

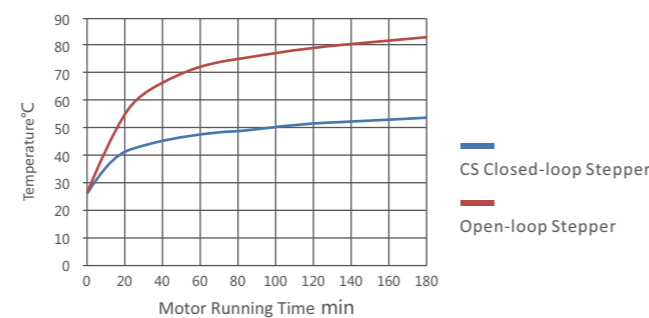
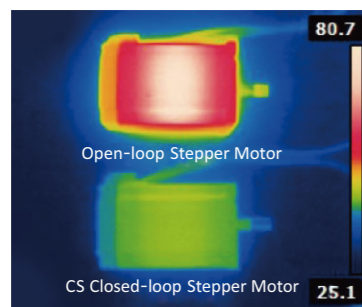

### 3 No Torque Reservation, Quicker Response and Enhanced Efficiency

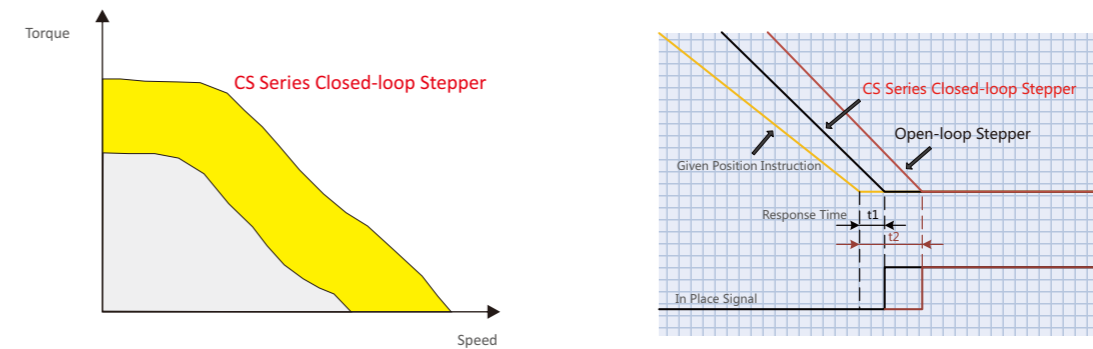

### 4 Smooth Motion and Extra Low Motor Noise

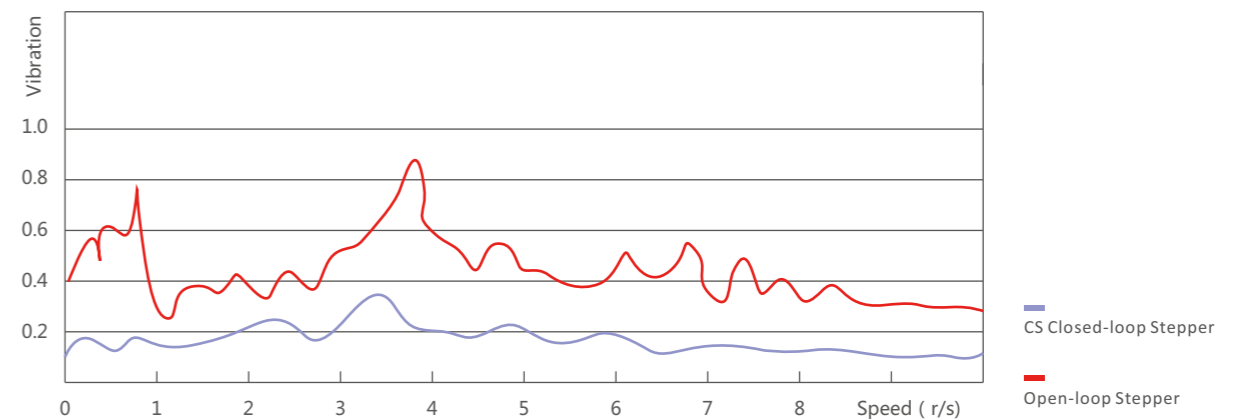

### 5 Drop-in Upgrade for Open-loop Stepper System, Easy Setup for No Tuning



No Tuning



Upgrade open-loop stepper





## 1.2 Applications

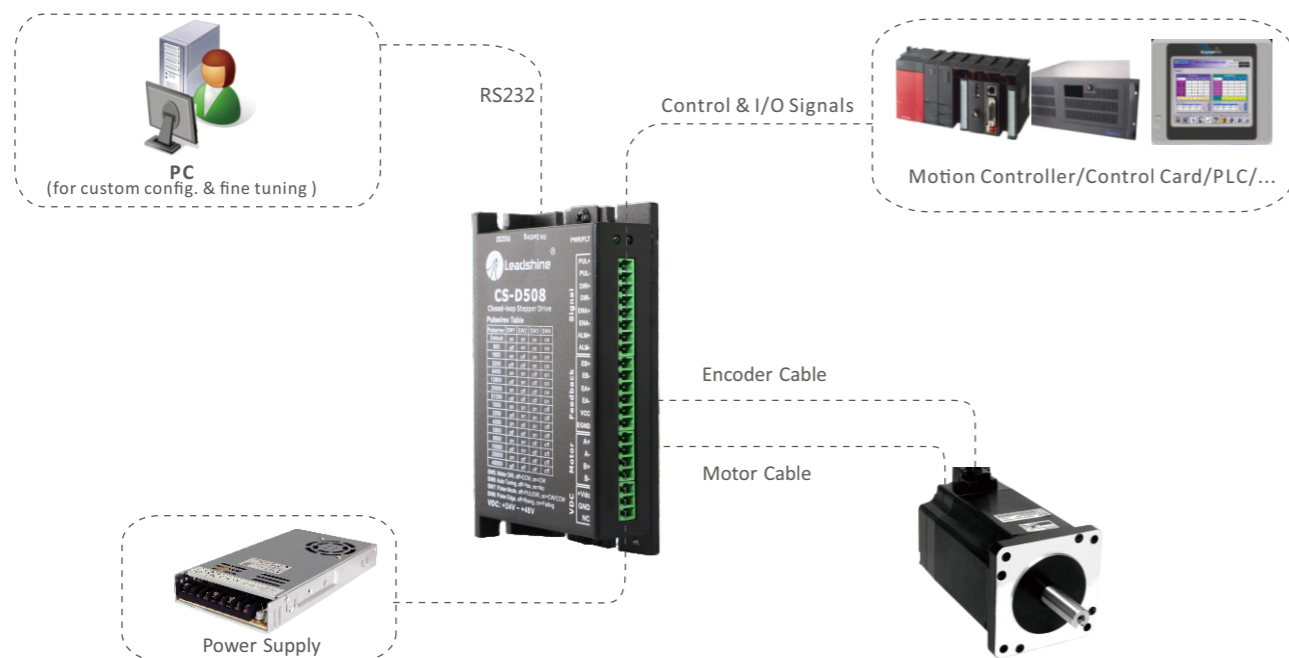







## 1.3 Typical Configuration



## 1.4 Matched Drives and Motors

Closed-loop Stepper Motors	NEMA17				NEMA23			NEMA24			
										CS-M22306	CS-M22313
0.6N.m										1.3N.m	2.3N.m
	CS-M21702	CS-M21704	CS-M21706	CS-M21708	CS-M22326	CS-M22321-L	CS-M22331-L	CS-M22422	CS-M22430		
	0.2N.m	0.4N.m	0.6N.m	0.8N.m	2.6N.m	2.1N.m	3.1N.m	2.2N.m	3N.m		
Closed-loop Stepper Drives	CS-D403				CS-D508						
											
	20-40VDC				20-50VDC						

Closed-loop Stepper Motors	NEMA 34				
	    				
	CS-M23435	CS-M23445	CS-M23480	CS-M23485	CS-M234120
	3.5N.m	4.5N.m	8.0N.m	8.5N.m	12N.m
Closed-loop Stepper Drives	CS-D808		CS-D1008		
					
	20-80VDC		20-80VAC or 30-110VDC		



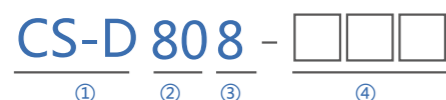

# 02 CS Series Drives

## 2.1 Part Number



- ① Series Name:  
CS - CS Series
- ② Operating Voltage:  
4 - max 40 VDC  
5 - max 50 VDC  
8 - max 80 VDC  
10 - max 80 VAC or 110VDC
- ③ Max Output Current:  
3 - 3A  
8 - 8A
- ④ 1-3 characters assigned for Custom models

## 2.2 Electrical Specifications

CS Series Drives				
Model				
	CS-D403	CS-D508	CS-D808	CS-D1008
Operating Voltage	20-40VDC	20-50VDC	20-80VDC	20-80VAC or 30-110VDC
Peak Output Current	0.5-3A	0.5-8A	0.5-8A	
Control Signal Voltage	5-24V			
Max. Input Frequency	200KHz (500KHz optional)			

## 2.3 Mechanical Specifications

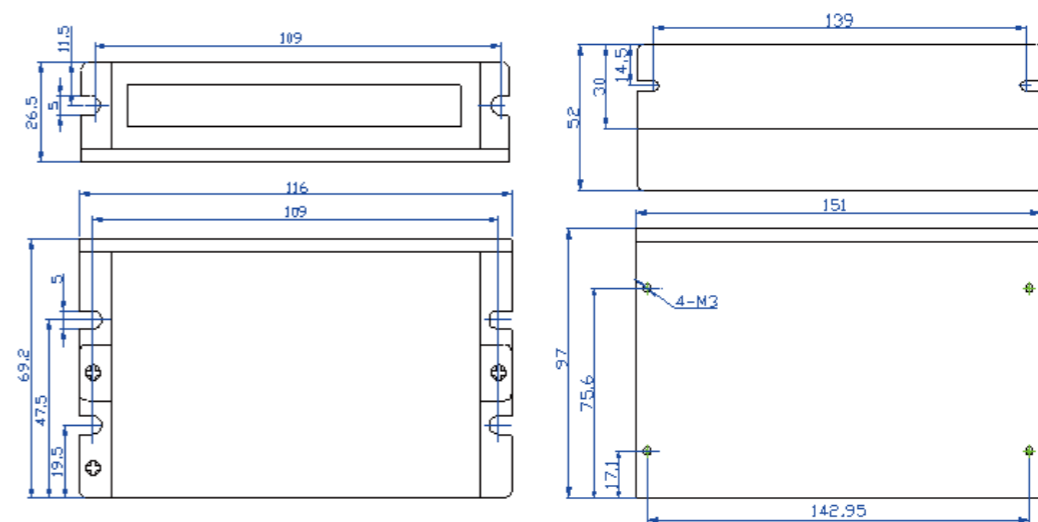

CS-D403/CS-D508

CS-D808/CS-D1008

### Installation

- Vertical mounting is suggested.
- Keep air circulation for heat dissipation. When necessary, add one or more cooling fans.
- When several CS-D drives are installed side by side, it is suggested to keep a minimal 50mm distance between each two of them

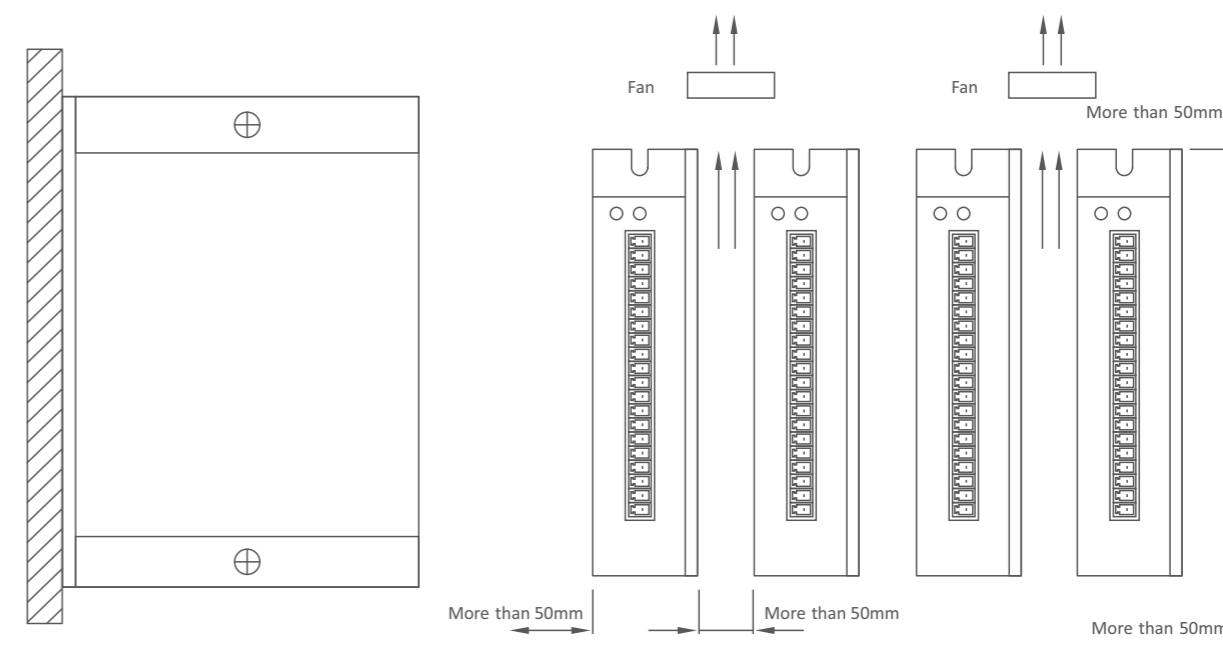

## 2.4 Connector Description

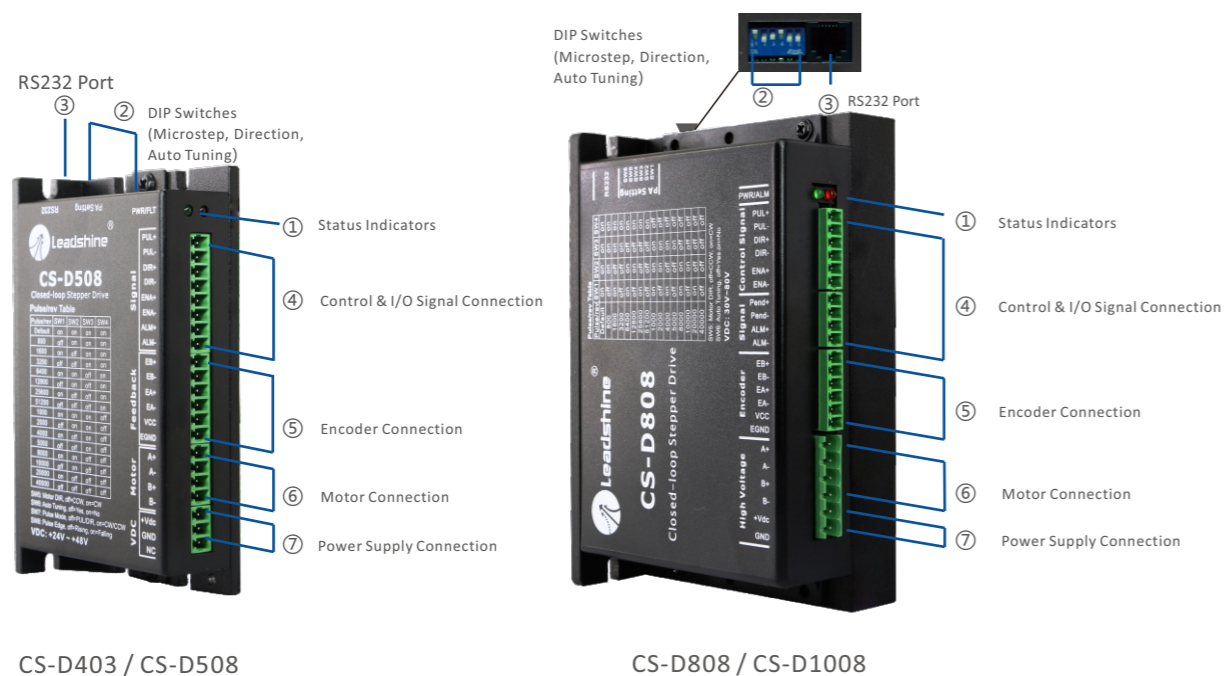

## 2 DIP Switch Configurations

CS-D403/CS-D508/ CS-D808/CS-D1008 SW1-SW4:

Steps/Revolution	SW1	SW2	SW3	SW4
Default (1600)	on	on	on	on
800	off	on	on	on
1600	on	off	on	on
3200	off	off	on	on
6400	on	on	off	on
12800	off	on	off	on
25600	on	off	off	on
51200	off	off	off	on
1000	on	on	on	off
2000	off	on	on	off
4000	on	off	on	off
5000	off	off	on	off
8000	on	on	off	off
10000	off	on	off	off
20000	on	off	off	off
40000	off	off	off	off

## 1 LED Indicator Description (PWR/ALM)

Color	Function	Description		
Green	Power Indicator PWR	The green indicator will be on constantly in normal condition.		
Red	Fault Indicator ALM	When protection function is enabled, it will flash 1,2 or 7 times in a 5-second period, different number of flashes indicates different protection type, as below:		
		Time(s) of blink	Sequence wave of red LED	Description
		1		Over-current protection activated when exceeding preset maximum current
		2		Over-voltage protection activated
7		Position following error		

CS-D403/CS-D508 SW5-SW8:

DIP Switch	Function	Description	
		ON	OFF
SW5	Initial Motor Movement Direction	Clockwise (CW)	Counterclockwise (CCW)
SW6	Disable Auto Tuning	Auto Tuning Off. Software tuning is available for this mode.	Auto drive self-tuning to match powered motor when power-on, and software tuning disabled.
SW7	Control Type	CW/CCW(double pulses)	PUL/DIR (Pulse & Direction)
SW8	Pulse Active Edge	Falling	Rising

CS-D808/CS-D1008 SW5-SW6:

DIP Switch	Function	Description	
		ON	OFF
SW5	Initial Motor Movement Direction	Clockwise (CW)	Counterclockwise (CCW)
SW6	Disable Auto Tuning	Auto Tuning Off. Software tuning is available for this mode.	Auto drive self-tuning to match powered motor when power-on, and software tuning disabled.

### 3 RS232 Communication Pinout

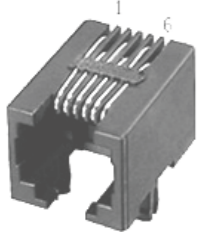
Picture	PIN	Name	Description
	1	NC	Reserved
	2	+5V	5V/50mA
	3	TxD	RS232 Transmit
	4	GND	Ground
	5	RxD	RS232 Receive
	6	NC	Reserved

### 4 Control & I/O Signals

Name	Description	Detail
PUL+	Pulse Input + ( CW+ in double pulse mode )	Signal activated at 4.5-24 VDC Signal inactive at 0-0.5 VDC
PUL-	Pulse Input - ( CW- in double pulse mode )	
DIR+	Direction Input + ( CCW+ in double pulse mode )	
DIR-	Direction Input - ( CCW- in double pulse mode )	
ENA+	Enable Input +	
ENA-	Enable Input -	The enable signal can be used to clear fault output of position following and over voltage errors. Although it is turned off by default, it can be enabled through software configuration
Pend+	In Place Output +	Only available for CS-D808 & CS-D1008, and no effect for CS-D403 and CS-D508
Pend-	In Place Output -	
ALM+	Alarm Output +	Optically isolated, max 24V/20mA
ALM-	Alarm Output -	

### 5 Encoder Connection

Name	Motor Wire Color (for Leadshine motors)	Description
EB+	Yellow	Encoder phase B+ connector
EB-	Green	Encoder phase B- connector
EA+	Black	Encoder phase A+ connector
EA-	Blue	Encoder phase A- connector
VCC	Red	Encoder +5V power connector
EGND	White	Encoder ground connector

### 6 Motor Connection

Name	Description
A+	Connect to Motor Phase A+ wire
A-	Connect to Motor Phase A- wire
B+	Connect to Motor Phase B+ wire
B-	Connect to Motor Phase B- wire

### 7 Power Supply Connection

Name	Description	Detail										
VDC/VCC	Connect to power supply ground connector	See suggested power supply voltage as below:										
GND/VCC	Connect to power supply positive connector	<table border="1"> <thead> <tr> <th>Drive</th> <th>Power Supply Voltage</th> </tr> </thead> <tbody> <tr> <td>CS-D403</td> <td>20-36VDC</td> </tr> <tr> <td>CS-D508</td> <td>20-48VDC</td> </tr> <tr> <td>CS-D808</td> <td>20-72VDC</td> </tr> <tr> <td>CS-D1008</td> <td>20-70VAC or 30-100VDC</td> </tr> </tbody> </table>	Drive	Power Supply Voltage	CS-D403	20-36VDC	CS-D508	20-48VDC	CS-D808	20-72VDC	CS-D1008	20-70VAC or 30-100VDC
		Drive	Power Supply Voltage									
		CS-D403	20-36VDC									
		CS-D508	20-48VDC									
		CS-D808	20-72VDC									
CS-D1008	20-70VAC or 30-100VDC											

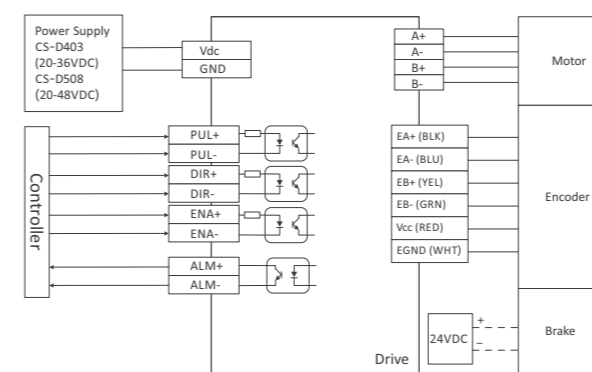

CS-D403/CS-D508 Typical Connection

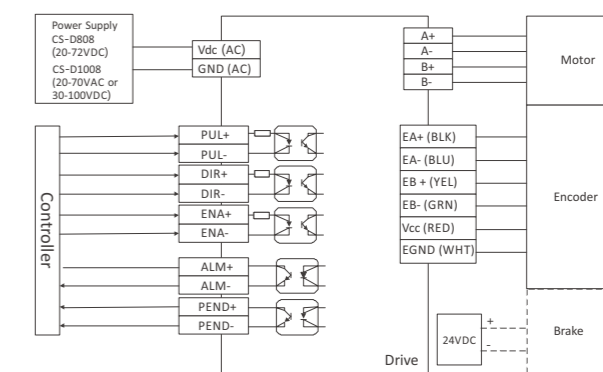

CS-D808/CS-D1008 Typical Connection

# 03 CS Series Motors

## 3.1 Part Number

CS-M 2 34 85 - □ □ □

- ① Motor Series  
CS-M series closed-loop stepper motor
- ② Motor Phase  
2: 2 phase motor
- ③ Motor Frame Size  
17: NEMA 17 motor  
23: NEMA 23 motor  
34: NEMA 34 motor
- ④ Holding Torque  
85: 8.5 N.m
- ④ Customized  
-S: Inch diameter  
-L: Large NEMA23 motor

## 3.2 Models

Motor Size	Model	Holding Torque (N.m)	Standard Type Length (mm)
NEMA17	CS-M21702	0.2	56
	CS-M21704	0.4	63
	CS-M21706	0.6	70
	CS-M21708	0.8	83
NEMA23	CS-M22306	0.6	62
	CS-M22313	1.3	77
	CS-M22323	2.3	97
	CS-M22326	2.6	105
	CS-M22321-L	2.1	88
NEMA24	CS-M22331-L	3.1	109
	CS-M22422	2.2	88
NEMA24	CS-M22430	3.0	109
	CS-M23435	3.5	95
NEMA34	CS-M23445	4.5	109
	CS-M23480	8.0	127
	CS-M23485	8.5	147
	CS-M234120	12	158

## 3.3 Motors Specifications (Unit: mm 1 inch=25.4mm)

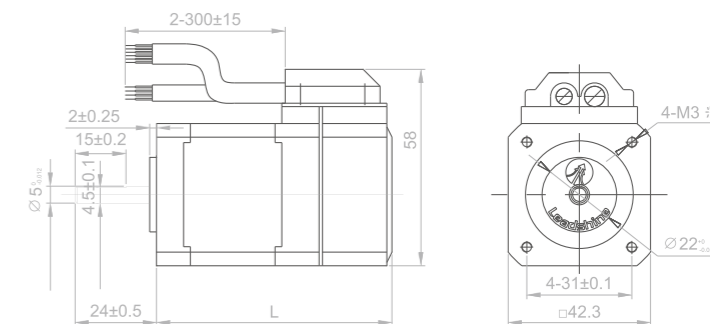
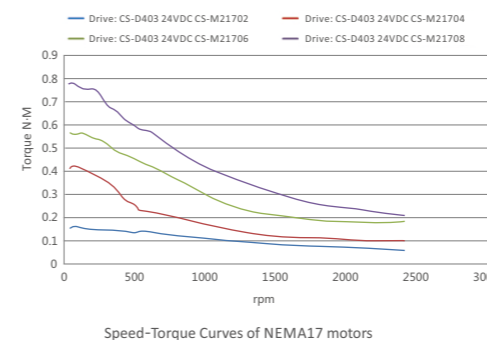

Model	Length L (mm)	Holding Torque (N.m)	Rate Current (A)	Inertia (Kg.cm <sup>2</sup> )	Weight (Kg)
CS-M21702	56	0.2	1.5	0.023	0.25
CS-M21704	63	0.4	1.5	0.045	0.35
CS-M21706	70	0.6	2.5	0.077	0.40
CS-M21708	83	0.8	2.5	0.110	0.55

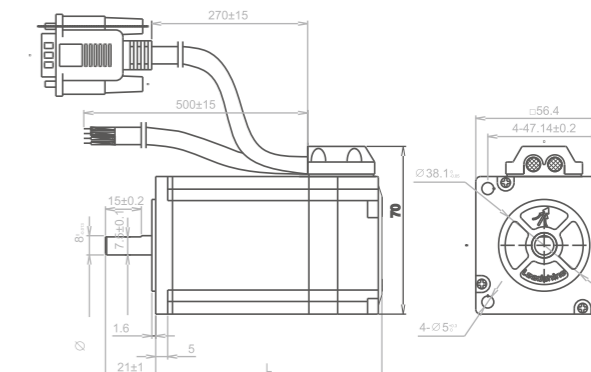
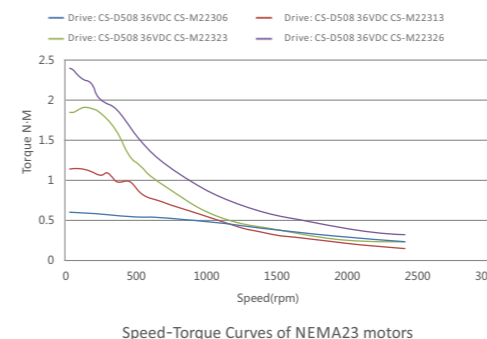

Model	Length L (mm)	Holding Torque (N.m)	Rate Current (A)	Inertia (Kg.cm <sup>2</sup> )	Weight (Kg)
CS-M22306	62	0.6	3.0	0.131	0.55
CS-M22313	77	1.3	4.0	0.30	0.80
CS-M22323	97	2.3	5.0	0.48	1.20
CS-M22326	105	2.6	5.0	0.7	1.40
CS-M22321-L	88	2.1	5.0	0.48	1.20
CS-M22331-L	109	3.1	5.0	0.69	1.48



Note:  
 \* Shaft diameter 6.35mm is available  
 \* Contact Leadshine for motor with brake and waterproof



# 04 Cables and Power Supplies

## 4.1 Cables

### 1 Motor and Encoder Extension Cables

Name	Picture	Model	Description
Motor extension cable		CABLEH-RZ1M5	1.5-meter power extension cable
		CABLEH-RZ3M0	3-meter power extension cable
		CABLEH-RZ5M0	5-meter power extension cable
		CABLEH-RZ8M0	8-meter power extension cable
		CABLEH-RZ10M0	10-meter power extension cable
Encoder extension Cable		CABLEH-BM1M5	1.5-meter power extension cable
		CABLEH-BM3M0	3-meter power extension cable
		CABLEH-BM5M0	5-meter power extension cable
		CABLEH-BM8M0	8-meter power extension cable
		CABLEH-BM10M0	10-meter power extension cable
		CABLEH-BM13M0	13-meter power extension cable

### 2 Picture for Motor Extension Cable



Side A	PIN 1	PIN 2	PIN 3	PIN 4
Color	Blue	Red	Black	Yellow/ Green
Define B	B-	A-	A+	B+

### 3 Picture for Encoder Extension Cable

Side A connecting with motor      Side B connecting with drive

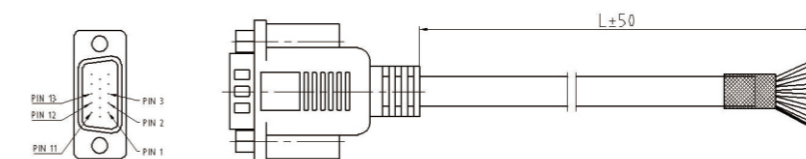

Side A	PIN 1	PIN 2	PIN 3	PIN 11	PIN 12	PIN 13
Color	Black	Yellow	White	Blue	Green	Red
Define B	A+	VCC	GND	B+	B-	A-

### 4 RS232 Cable

CABLE-PC	
	<ul style="list-style-type: none"> <li>Length 1.5m</li> <li>For connecting with ProTuner</li> </ul>
Note : Please connect with a RS232 to USB converter if the PC without RS232 serial port	

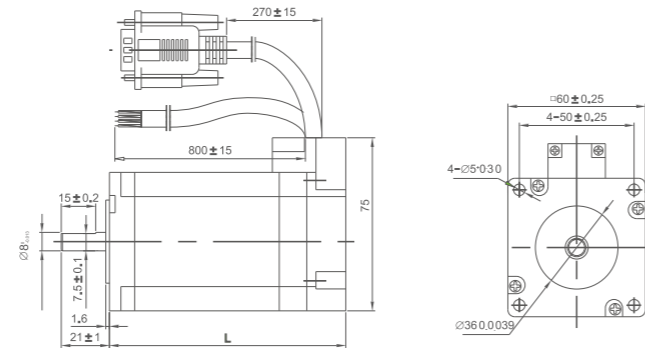
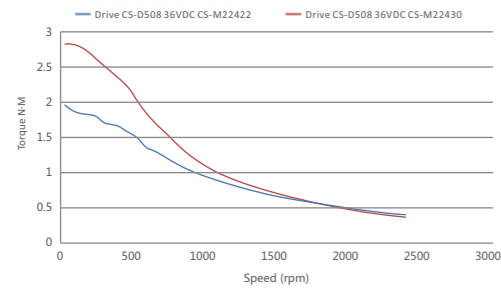

Model	Length L (mm)	Holding Torque (N.m)	Rate Current (A)	Inertia (Kg.cm <sup>2</sup> )	Weight (Kg)
CS-M22422	88	2.2	5.0	0.49	1.2
CS-M22430	109	3.0	5.0	0.69	1.5

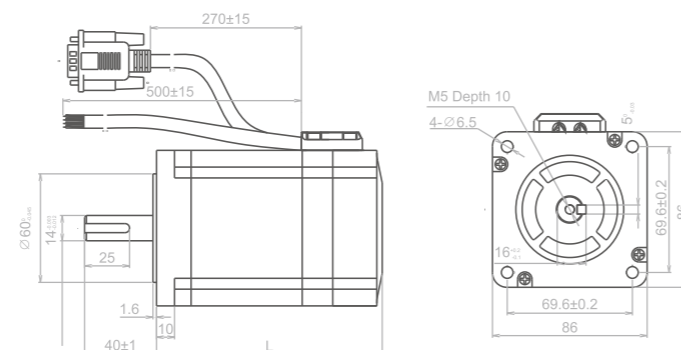
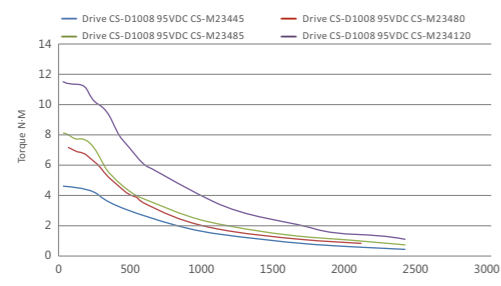

Model	Length L (mm)	Holding Torque (N.m)	Rate Current (A)	Inertia (Kg.cm <sup>2</sup> )	Weight (Kg)
CS-M23435	95	3.5	4.0	1.75	2.1
CS-M23445	109	4.5	6.0	1.95	2.7
CS-M23480	127	8.0	6.0	2.5	3.7
CS-M23485	147	8.5	6.0	2.8	4.0
CS-M234120	158	12.0	7.0	3.0	4.9

Note :  
 \* Shaft diameter 12.7 mm is available  
 \* Contact Leadshine for motor with brake and waterproof

## 4.2 Power Supplies

### 1 SPS Series Power Supplies

#### ■ Features

- Specially Designed Power Supplies for Stepper and Servo Controls
- Compact Size, Light in Weight
- Wide Input Voltage Range, 220VAC ± 10% or 110 VAC ± 10%
- Shortcut, Over-current, Over-voltage, Low-voltage Protections Big
- Power with High Efficiency
- Easy to Use



#### ■ Electrical Specifications

Model	Output Voltage (VDC)	Continuous Current (A)	Peak Current (A)	Input Voltage	Matching Drives	Dimensions	Weight (Kg)
SPS2410(V2.0)	24	10	30	220VAC± 10% or 110 VAC ± 10%	CS-D403/ CS-D508	199*110*50mm	0.8
SPS3611(V2.0)	36	11	33		CS-D508	215*110*30mm	0.6
SPS488(V2.0)	48	8.3	24.9		CS-D508/CS-D808	215*110*30mm	0.6
SPS4810(V2.0)	48	10	30		CS-D508/CS-D808	215*110*50mm	0.8
SPS606(V2.0)	60	6.7	20.1		CS-D808/CS-D1008	215*110*30mm	0.6

#### ■ Mechanical Specifications

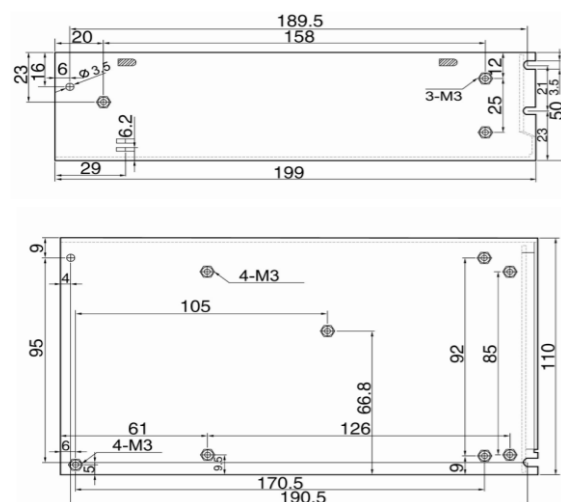

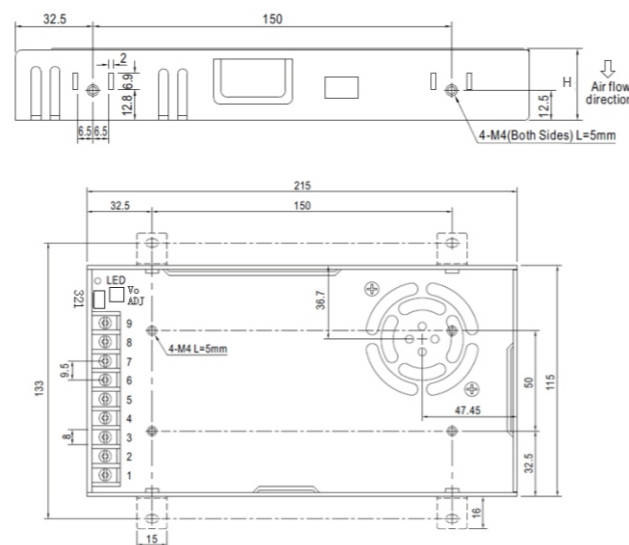

SPS2410(V2.0)



SPS3611(V2.0)/SPS488(V2.0)/SPS606(V2.0) H=30mm  
SPS4810(V2.0) H=50mm

## 05 Ordering Information

### CS Series Closed-loop Stepper Drives Ordering Guidance

	CS-D403	CS-D508	CS-D808 / CS-D1008
<b>Closed-loop Stepper Drives</b>			
<b>Closed-loop Stepper Motors</b>	CS-M21702 CS-M21704 CS-M21706 CS-M21708	CS-M22306 CS-M22313 CS-M22323 CS-M22326 CS-M22321-L CS-M22331-L	CS-M23435 CS-M23445 CS-M23480 CS-M23485 CS-M234120
<b>Accessories</b>	CABLEH-RZ series motor extension cable		
	CABLEH-BM series encoder extension cable		
	CABLE-PC Communication cable		