



APEX DYNAMICS, INC.

**HIGH PERFORMANCE
HYPOID GEARBOX**

KH / KF Series



Planetary Gearbox Series

► Features:

Innovative Hypoid Helical Bevel Gear

Optimized Inertia Moment

High Positioning Accuracy

High Efficiency

Low Noise

Long Service Life

Flexible Mounting

Multiple Output Types

Same Rotating Direction on Output as the Servo-Motor

The output shaft of APEX K-series rotates in the same direction as the servo-motor that simplifies the machine control and setting.



KH

KF-S1 / S2

KF-S3

KF-S4



© 2019 by APEX DYNAMICS, INC.

APEX DYNAMICS, INC. reserves modification and copyrights of all technical specifications, illustrations and drawings in this catalog in allowance for continuous products development and advancement.

For the newest data and information, please visit <http://www.apexdyna.com/>

ORDERING CODE

KF — **010⁽¹⁾** — **S1⁽²⁾** / **MOTOR**

KH — **010⁽¹⁾** / **MOTOR**

Motor Type :
Manufacturer and Model

Ratio⁽¹⁾:

1-stage: 3, 4, 5, 7, 10

2-stage: 12, 16, 20, 25, 28, 35, 40, 50, 70, 100

Spiral Bevel

Ratio⁽¹⁾:

1-stage: 1, 2

Gear Size:

KF : KF060, KF075, KF100, KF140, KF180, KF210, KF240

KF(Spiral Bevel) : KF060, KF075, KF100, KF140, KF180, KF210, KF240

KH : KH064, KH090, KH110, KH140, KH200, KH255, KH285

Ordering Example : KF100 - 010 - S1 / SIEMENS 1FT6 041 - 4AF71

(1) Ratio ($i = N_{in} / N_{out}$).

(2) S1 = Smooth Output Shaft.

S2 = Output Shaft with Key.

S3 = DIN 5480 Output Shaft.

S4 = Hollow Output Shaft.

KH Gearbox Performance

Model No.	Stages	Ratio ⁽¹⁾	KH 064	KH 090	KH 110	KH 140	KH 200	KH 255	KH 285		
Nominal Output Torque T _{2N}	1	3	25	50	110	210	420	820	1600		
		4	25	60	110	210	420	820	1600		
		5	25	60	110	210	420	820	1600		
		7	23	50	100	200	390	750	1400		
		10	18	40	85	170	360	600	1100		
	2	12	25	60	110	210	420	820	1600		
		16	25	60	110	210	420	820	1600		
		20	25	60	110	210	420	820	1600		
		25	25	60	110	210	420	820	1600		
		28	25	60	110	210	420	820	1600		
		35	25	60	110	210	420	820	1600		
		40	25	60	110	210	420	820	1600		
		50	25	60	110	210	420	820	1600		
		70	23	50	100	200	390	750	1400		
		100	18	40	85	170	360	600	1100		
Emergency Stop Torque T _{2NOT}	Nm	1,2	3~100							2 times T _{2N}	
Max. Acceleration Torque T _{2B}	Nm	1,2	3~100							1,5 times T _{2N}	
No Load Running Torque ⁽⁴⁾	Nm	1	3~10	0.9	1.6	3.2	4.2	9.6	16.5	26.4	
		2	12~100	0.1	0.1	0.2	0.4	1.1	1.9	3	
Backlash ⁽²⁾	arcmin	1	3~10	≤ 3	≤ 3	≤ 3	≤ 3	≤ 3	≤ 3	≤ 3	
		2	12~100	≤ 3	≤ 3	≤ 3	≤ 3	≤ 3	≤ 3	≤ 3	
Torsional Rigidity	Nm/arcmin	1,2	3~100	1.1	4.5	10	23	54	90	170	
Nominal Input Speed n _{1N}	rpm	1	3~10	3,000	2,800	2,700	2,000	2,000	2,000	1,500	
		2	12~100	5,500	4,600	4,600	4,000	3,700	3,400	3,100	
Max. Input Speed n _{1B}	rpm	1	3~10	6,000	6,000	4,500	4,500	4,000	3,000	2,500	
		2	12~100	7,000	7,000	7,000	6,000	5,500	5,000	4,500	
Max. Radial Load F _{2r} ⁽³⁾	N	1,2	3~100	2,400	4,500	5,100	13,000	28,700	36,200	58,300	
Max. Axial Load F _{2a} ⁽³⁾	N	1,2	3~100	1,200	2,250	2,550	6,500	14,350	18,100	29,150	
Operating Temp	° C	1,2	3~100							0° C~ +90° C	
Degree of Gearbox Protection		1,2	3~100							IP65	
Lubrication		1,2	3~100							Synthetic lubrication grease	
Mounting Position		1,2	3~100							All directions	
Running Noise ⁽⁴⁾	dB(A)	1,2	3~100	≤ 64	≤ 66	≤ 66	≤ 68	≤ 68	≤ 70	≤ 72	
Efficiency η	%	1	3~100							≥ 96%	
		2	12~100							≥ 94%	

(1) Ratio (i= N_{in} / N_{out}) .

(2) Backlash is measured at 2% of Nominal Output Torque T_{2N}.

(3) Applied to the output shaft center at 100 rpm.

(4) The dB values are measured by gearbox with ratio 10 (1-stage) or ratio 100 (2-stage), no loading at 3,000 RPM or at the respective Nominal Input Speed by bigger model size.

By lower ratio and/or higher RPM, the noise level could be 3 to 5 dB higher.

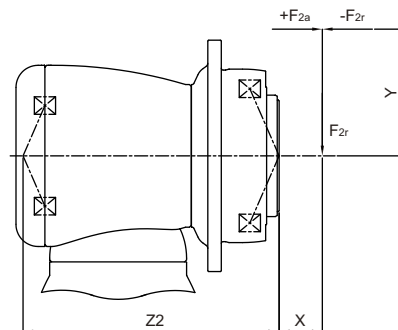

$$M_{2k} = \frac{F_{2a} \times Y + F_{2r} \times (X + Z_2)}{1000}$$

M_{2k} : 【Nm】

F_{2a} , F_{2r} : 【N】

X , Y , Z₂ : 【mm】

KH	KH 064	KH 090	KH 110	KH 140	KH 200	KH 255	KH 285
Z ₂ 【mm】	95.7	121.9	148.9	192.6	259.5	290.9	353.7
M _{2k} 【Nm】	230	460	760	1,730	3,870	7,800	15,200

KH Gearbox Inertia

Model No.		KH 064		KH 090		KH 110		KH 140		KH 200		KH 255		KH 285	
$\emptyset^{(A)}$ (C3)		1-stage	2-stage	1-stage	2-stage	1-stage	2-stage	1-stage	2-stage	1-stage	2-stage	1-stage	2-stage	1-stage	2-stage
8	kg.cm ²	0.1	0.1	-	-	-	-	-	-	-	-	-	-	-	-
11		0.17	0.16	0.18	0.17	-	-	-	-	-	-	-	-	-	-
14		0.21	0.2	0.5	0.21	-	0.53	-	-	-	-	-	-	-	-
19		0.62	-	0.65	0.63	1.69	0.68	-	1.83	-	-	-	-	-	-
24		-	-	4.49	-	4.89	4.52	5.05	5.04	-	5.63	-	-	-	-
28		-	-	-	-	6.14	-	6.55	6.33	-	7.18	-	-	-	-
32		-	-	-	-	8.54	-	9.47	8.73	10.18	10.1	-	12.63	-	-
35		-	-	-	-	13.86	-	14.91	14.04	15.21	15.54	15.68	17.75	23.46	20.8
38		-	-	-	-	18.87	-	20.69	19.05	20.7	21.32	21.69	23.26	23.46	27.05
42		-	-	-	-	-	-	22.58	-	22.83	23.2	23.59	25.4	25.28	28.95
48		-	-	-	-	-	-	55.45	-	58.45	56.07	59.3	61.02	61.61	64.66
55		-	-	-	-	-	-	-	-	-	-	86.95	-	89.67	-
60		-	-	-	-	-	-	-	-	-	-	-	-	112.49	-

(A) \emptyset = Input shaft diameter.

Permitted Radial And Axial Loads

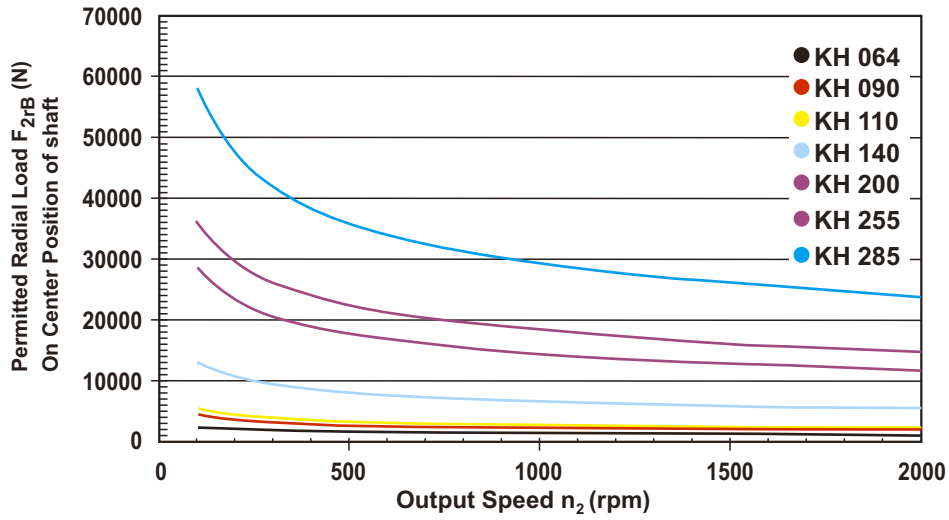

Permitted radial load F_{2r} on center of output flange on various output speeds.

KH Series Dimension

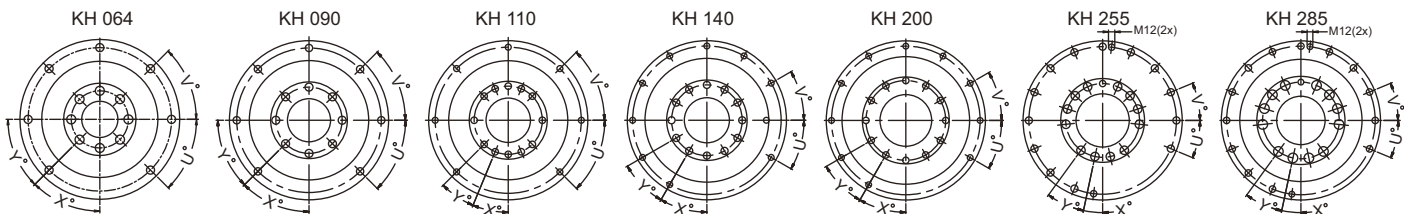
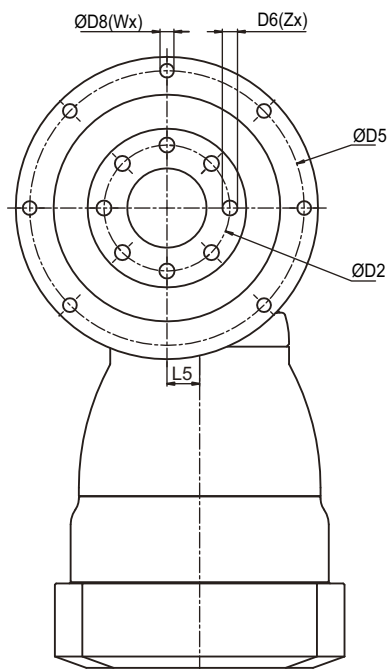
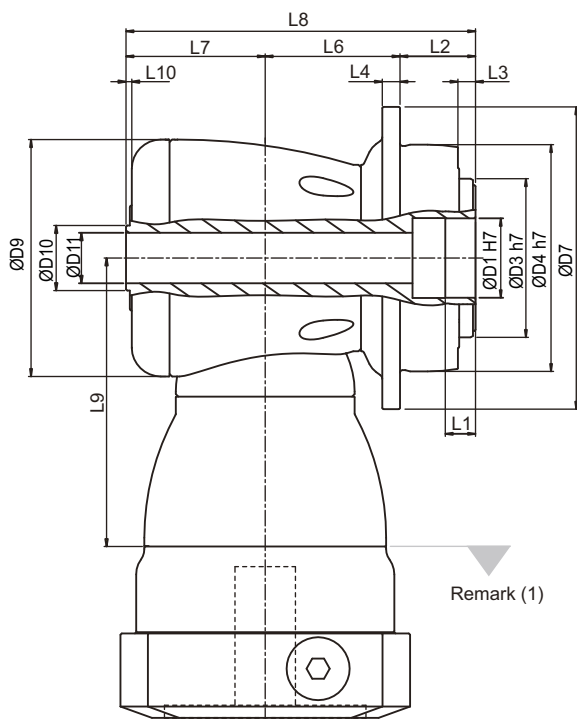

Dimension	KH 064	KH 090	KH 110	KH 140	KH 200	KH 255	KH 285
	1~2-stage	1~2-stage	1~2-stage	1~2-stage	1~2-stage	1~2-stage	1~2-stage
D1 H7	20	31.5	40	50	80	100	100
D2	31.5	50	63	80	125	140	160
D3 h7	40	63	80	100	160	180	200
D4 h7	64	90	110	140	200	255	285
D5	79	109	135	168	233	280	310
D6	M5x0.8Px8	M6x1Px10	M6x1Px12	M8x1.25Px15	M10x1.5Px20	M16x2Px25	M20x2.5Px31
D7	88	120	147	180	249.5	302	332
D8	4.5	5.5	5.5	6.6	9	13.5	13.5
D9	73	94	116	163	210	255	300
D10	18.5	25.8	36.8	55.2	69.2	82.2	92.2
D11 +0.5 / 0 ⁽²⁾	10	20	28	40	55	62	70
L1	8	12	12	12	16	20	20
L2	19.5	30	29	38	50	66	75
L3	4	7	7	7.5	8.5	13.5	16.5
L4	5	7	8	10	12	18	20
L5	10	13	17	25	31	36	43
L6	43	53.5	67	81	117	132	160.5
L7	46	55.3	71.3	91.8	118	134	168
L8	108.5	138.8	167.3	210.8	285	332	403.5
L9	94	114.5	129	173.5	228	265.5	294.5
L10	1.5	2.3	3	2.8	3	3	3
X in Degree	45°	45°	22.5°	30°	30°	12°	12°
Y in Degree	45°	45°	22.5°	30°	30°	24°	24°
Z	8	8	12	12	12	12	12
U in Degree	45°	45°	45°	30°	30°	22.5°	22.5°
V in Degree	45°	45°	45°	30°	30°	22.5°	22.5°
W	7	7	7	10	10	13	13

(1) Dimensions are related to motor interface. Please contact APEX for details.

(2) Let through element max. Ø(D11-0.2)mm.

KF Gearbox Performance

Model No.	Stages	Ratio ⁽¹⁾	KF 060	KF 075	KF 100	KF 140	KF 180	KF 210	KF 240	
Nominal Output Torque T _{2N}	1	3	25	50	110	210	420	820	1600	
		4	25	60	110	210	420	820	1600	
		5	25	60	110	210	420	820	1600	
		7	23	50	100	200	390	750	1400	
		10	18	40	85	170	360	600	1100	
	2	12	25	60	110	210	420	820	1600	
		16	25	60	110	210	420	820	1600	
		20	25	60	110	210	420	820	1600	
		25	25	60	110	210	420	820	1600	
		28	25	60	110	210	420	820	1600	
		35	25	60	110	210	420	820	1600	
		40	25	60	110	210	420	820	1600	
		50	25	60	110	210	420	820	1600	
		70	23	50	100	200	390	750	1400	
		100	18	40	85	170	360	600	1100	
		Emergency Stop Torque T _{2NOT}	Nm	1,2	3~100 2 times T _{2N}					
Max. Acceleration Torque T _{2B}	Nm	1,2	3~100 1,5 times T _{2N}							
No Load Running Torque ⁽⁴⁾	Nm	1	3~10	0.8	1.3	2.6	3.5	8	11	17.6
		2	12~100	0.1	0.1	0.2	0.3	0.9	1.2	1.9
Backlash ⁽²⁾	arcmin	1	3~10	≤ 3	≤ 3	≤ 3	≤ 3	≤ 3	≤ 3	≤ 3
		2	12~100	≤ 3	≤ 3	≤ 3	≤ 3	≤ 3	≤ 3	≤ 3
Torsional Rigidity	Nm/arcmin	1,2	3~100	0.8	3.5	9	20.5	44	80	168
Nominal Input Speed n _{1N}	rpm	1	3~10	3,000	2,800	2,700	2,000	2,000	2,000	1,500
		2	12~100	5,500	4,500	4,200	3,900	3,400	2,800	2,200
Max. Input Speed n _{1B}	rpm	1	3~10	6,000	6,000	4,500	4,500	4,000	3,000	2,500
		2	12~100	7,000	7,000	7,000	6,000	5,500	5,000	4,500
Max. Radial Load F _{2r} ⁽³⁾	N	1,2	3~100	5,700	8,200	12,200	20,100	30,700	40,900	51,900
Max. Axial Load F _{2a} ⁽³⁾	N	1,2	3~100	2,850	4,100	6,100	10,050	15,350	20,450	20,950
Service Life ⁽⁵⁾	hr	1,2	3~100	20,000						
Operating Temp	° C	1,2	3~100	0° C~ +90° C						
Degree of Gearbox Protection		1,2	3~100	IP65						
Lubrication		1,2	3~100	Synthetic lubrication grease						
Mounting Position		1,2	3~100	All directions						
Running Noise ⁽⁴⁾	dB(A)	1,2	3~100	≤ 64	≤ 66	≤ 66	≤ 68	≤ 68	≤ 70	≤ 72
Efficiency η	%	1	3~10	≥ 96%						
		2	12~100	≥ 94%						

(1) Ratio (i= N_{in} / N_{out}).

(2) Backlash is measured at 2% of Nominal Output Torque T_{2N}.

(3) Applied to the output shaft center at 100 rpm.

(4) The dB values are measured by gearbox with ratio 10 (1-stage) or ratio 100 (2-stage), no loading at 3,000 RPM or at the respective Nominal Input Speed by bigger model size.

By lower ratio and/or higher RPM, the noise level could be 3 to 5 dB higher.

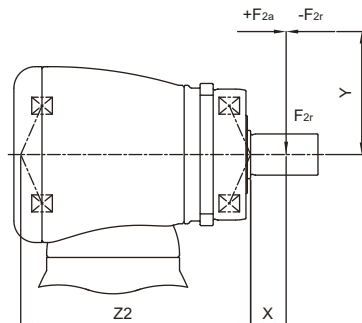

$$M_{2k} = \frac{F_{2a} \times Y + F_{2r} \times (X + Z_2)}{1000}$$

M_{2k} : 【Nm】

F_{2a}, F_{2r} : 【N】

X, Y, Z₂ : 【mm】

KF	KF 060	KF 075	KF 100	KF 140	KF 180	KF 210	KF 240
Z ₂ 【mm】	96.3	111.9	150.1	192	231.1	289.2	355.1
M _{2k} 【Nm】	310	530	1,090	2,340	5,400	9,700	15,200

KF Gearbox Inertia

Model No.	KF 060		KF 075		KF 100		KF 140		KF 180		KF 210		KF 240	
$\varnothing^{(A)}$ (C3)	1-stage	2-stage	1-stage	2-stage	1-stage	2-stage	1-stage	2-stage	1-stage	2-stage	1-stage	2-stage	1-stage	2-stage
8	0.1	0.1	-		-	-	-	-	-	-	-	-	-	-
11	0.17	0.16	0.18	0.17	-	-	-	-	-	-	-	-	-	-
14	0.21	0.2	0.5	0.21	-	0.53	-	-	-	-	-	-	-	-
19	0.62	-	0.65	0.63	1.69	0.68	-	1.83	-	-	-	-	-	-
24	-	-	4.49	-	4.89	4.52	5.05	5.04	-	5.63	-	-	-	-
28	-	-	-	-	6.14	-	6.55	6.33	-	7.18	-	-	-	-
32	kg.cm ²	-	-	-	8.54	-	9.47	8.73	10.18	10.1	-	12.63	-	-
35	-	-	-	-	13.86	-	14.91	14.04	15.21	15.54	15.68	17.75	23.46	20.8
38	-	-	-	-	18.87	-	20.69	19.05	20.7	21.32	21.69	23.26	23.46	27.05
42	-	-	-	-	-	-	22.58	-	22.83	23.2	23.59	25.4	25.28	28.95
48	-	-	-	-	-	-	55.45	-	58.45	56.07	59.3	61.02	61.61	64.66
55	-	-	-	-	-	-	-	-	-	-	86.95	-	89.67	-
60	-	-	-	-	-	-	-	-	-	-	-	-	112.49	-

(A) \varnothing = Input shaft diameter.

Permitted Radial And Axial Loads^(A)

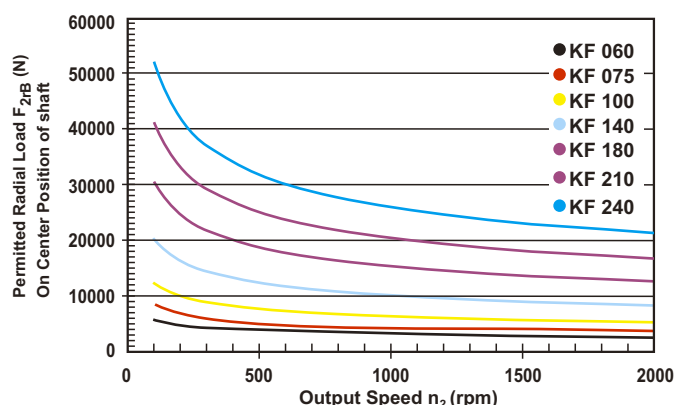
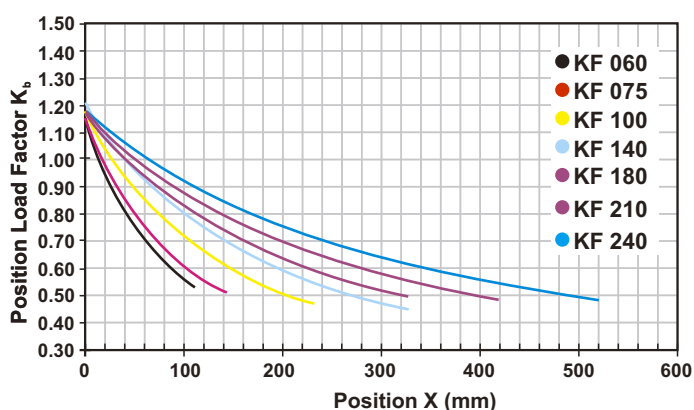

If radial force F_{2r} is not exerted on the center of the output shaft $X < 1/2 L$ or $X > 1/2 L$, the permitted radial and axial loads can be calculated by the position load factor K_b on the above diagram.

Permitted radial load F_{2r} on center of output shaft. $X = 1/2 L$ for various output speeds.

(A) Permitted loading values on the output shaft. Please refer to P. 16 glossary.

KF-S1 / S2 / S3 Series Dimension

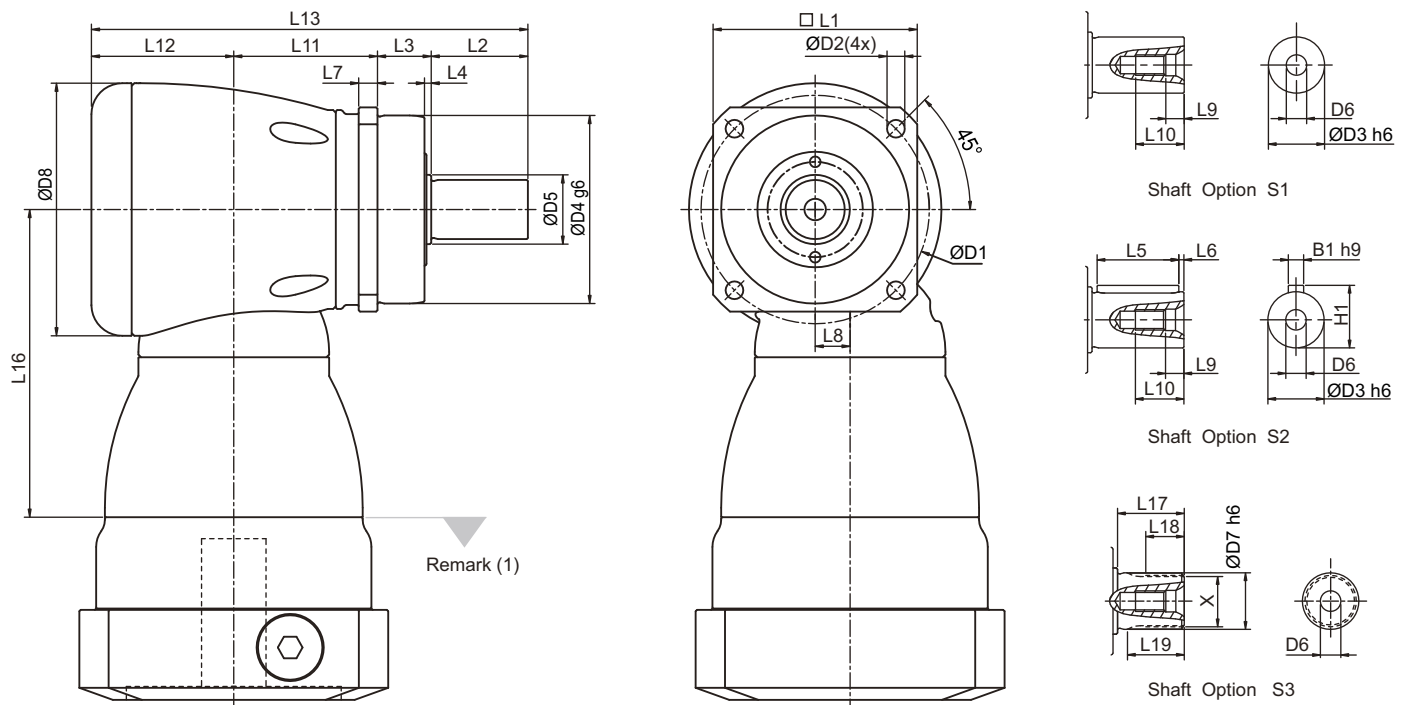

Dimension	KF 060	KF 075	KF 100	KF 140	KF 180	KF 210	KF 240	
	1~2-stage	1~2-stage	1~2-stage	1~2-stage	1~2-stage	1~2-stage	1~2-stage	
D1	68	85	120	165	215	250	290	
D2	5.5	6.6	9	11	13.5	17	17	
D3 h6	16	22	32	40	55	75	85	
D4 g6	60	70	90	130	160	180	200	
D5	18.5	25.8	36.8	55.2	69.2	82.2	92.2	
D6	M5X0.8P	M8X1.25P	M12X1.75P	M16X2P	M20X2.5P	M20X2.5P	M20X2.5P	
D7 h6	16	22	32	40	55	75	85	
D8	73	94	116	163	210	255	300	
L1	62	76	101	141	182	215	245	
L2	28	36	58	82	82	105	130	
L3	20	20	30	30	30	38	40	
L4	2	2.5	3	3	3	3	3	
L5	25	32	50	63	70	90	125	
L6	2	2	4	5	6	7	3	
L7	6	7	10	12	15	17	20	
L8	10	13	17	25	31	36	43	
L9	4.8	7.2	10	12	15	15	15	
L10	12.5	19	28	36	42	42	42	
L11	43	53.5	67	90	119	141	176	
L12	44.5	53	68.3	89	115	131	165	
L13	135.5	162.5	223.3	291	346	415	511	
L16	94	114.5	129	173.5	228	265.5	294.5	
L17	26	26	26	40	41.5	52	60	
L18	15	15	15	20	21.5	28	36	
L19	21	22.5	23	33.5	33.5	45	53	
B1 h9	5	6	10	12	16	20	22	
H1	18	24.5	35	43	59	79.5	90	
X	DIN 5480	W16x0.8x30x18x6m	W22x1.25x30x16x6m	W32x1.25x30x24x6m	W40x2x30x18x6m	W55x2x30x26x6m	W70x2x30x34x6m	W80x2x30x38x6m

(1) Dimensions are related to motor interface. Please contact APEX for details.

KF-S4 Series Dimension

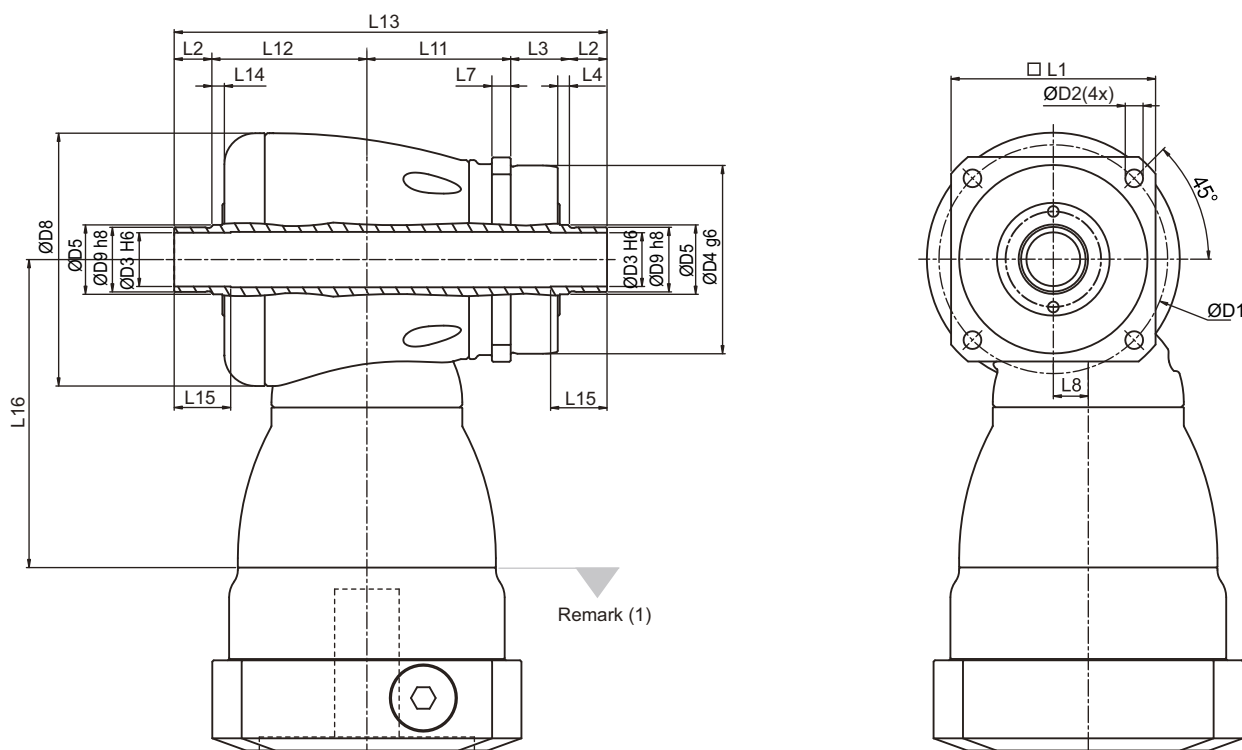

Dimension	KF 060	KF 075	KF 100	KF 140	KF 180
	1~2-stage	1~2-stage	1~2-stage	1~2-stage	1~2-stage
D1	68	85	120	165	215
D2	5.5	6.6	9	11	13.5
D3 H6	15	20	30	40	55
D4 g6	60	70	90	130	160
D5	18.5	25.8	36.8	55.2	69.2
D8	73	94	116	163	210
D9 h8	18	24	36	50	68
L1	62	76	101	141	182
L2	12	14	18	22	23
L3	22	21.8	32	33	34
L4	4	4.3	5	6	7
L7	6	7	10	12	15
L8	10	13	17	25	31
L11	43	53.5	67	90	119
L12	48.5	57.7	73.3	95	122
L13	137.5	161	208.3	262	321
L14	4	4.7	5	6	7
L15	19	21	25	30	30
L16	94	114.5	129	173.5	228

(1) Dimensions are related to motor interface. Please contact APEX for details.

KF Gearbox Performance (Spiral Bevel)

Model No.	Stages	Ratio ⁽¹⁾	KF 060	KF 075	KF 100	KF 140	KF 180	KF 210	KF 240	
Nominal Output Torque T _{2N}	Nm	1	25	45	78	150	360	585	1,300	
		2	24	42	68	150	330	544	1,220	
Emergency Stop Torque T _{2NOT}	Nm	1	2 times T _{2N}							
Max. Acceleration Torque T _{2B}	Nm	1	1,5 times T _{2N}							
No Load Running Torque ⁽⁴⁾	Nm	1	1~2	0.3	0.3	1.5	1.7	5.5	9	20
Backlash ⁽²⁾	arcmin	1	1~2	≤ 3	≤ 3	≤ 3	≤ 3	≤ 3	≤ 3	≤ 3
Torsional Rigidity	Nm/arcmin	1	1~2	0.8	3.5	9	20.5	44	80	168
Nominal Input Speed n _{1N}	rpm	1	1~2	6,500	4,500	3,500	2,000	1,500	1,200	1,000
Max. Input Speed n _{1B}	rpm	1	1~2	7,500	6,500	5,500	4,500	3,500	3,000	2,200
Max. Radial Load F _{2r} ⁽³⁾	N	1	1~2	5,400	7,700	11,100	18,100	29,100	36,400	46,900
Max. Axial Load F _{2a} ⁽³⁾	N	1	1~2	2,700	3,850	5,550	9,050	14,550	18,200	23,450
Operating Temp	°C	1	1~2	0° C~ +90° C						
Degree of Gearbox Protection		1	1~2	IP65						
Lubrication		1	1~2	Synthetic lubrication grease						
Mounting Position		1	1~2	All directions						
Running Noise ⁽⁴⁾	dB(A)	1	1~2	≤ 68	≤ 70	≤ 74	≤ 76	≤ 77	≤ 78	≤ 80
Efficiency η	%	1	1~2	≥ 97%						

(1) Ratio (i= N_{in} / N_{out}) .

(2) Backlash is measured at 2% of Nominal Output Torque T_{2N}.

(3) Applied to the output shaft center at 100 rpm.

(4) The dB values are measured by gearbox with ratio 2 (1-stage), no loading at 3,000 RPM or at the respective Nominal Input Speed by bigger model size.
By lower ratio and/or higher RPM, the noise level could be 3 to 5 dB higher.

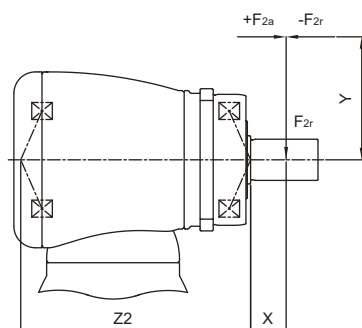

$$M_{2k} = \frac{F_{2a} \times Y + F_{2r} \times (X + Z_2)}{1000}$$

M_{2k} : 【Nm】

F_{2a}, F_{2r} : 【N】

X, Y, Z₂ : 【mm】

KF 【Spiral Bevel】	KF 060	KF 075	KF 100	KF 140	KF 180	KF 210	KF 240
Z ₂ 【mm】	104.4	119.3	144.3	178	251.9	253.9	330.8
M _{2k} 【Nm】	390	630	1,100	2,230	5,020	6,430	10,810

KF Gearbox Inertia (Spiral Bevel)

Model No.		KF 060	KF 075	KF 100	KF 140	KF 180	KF 210	KF 240
$\varnothing^{(A)}$ (C3)		1-stage	1-stage	1-stage	1-stage	1-stage	1-stage	1-stage
8	kg.cm ²	0.1	-	-	-	-	-	-
11		0.17	0.18	-	-	-	-	-
14		0.21	0.5	-	-	-	-	-
19		0.62	0.65	1.69	-	-	-	-
24		-	4.49	4.89	5.05	-	-	-
28		-	-	6.14	6.55	-	-	-
32		-	-	8.54	9.47	10.18	-	-
35		-	-	13.86	14.91	15.21	15.68	23.46
38		-	-	18.87	20.69	20.7	21.69	23.46
42		-	-	-	22.58	22.83	23.59	25.28
48		-	-	-	55.45	58.45	59.3	61.61
55		-	-	-	-	-	86.95	89.67
60		-	-	-	-	-	-	112.49

(A) \varnothing = Input shaft diameter.

Permitted Radial And Axial Loads^(A)

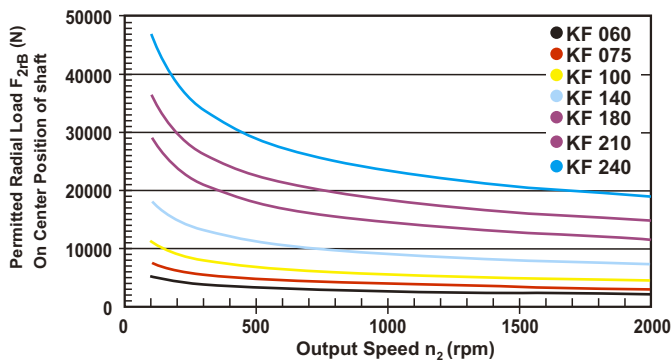
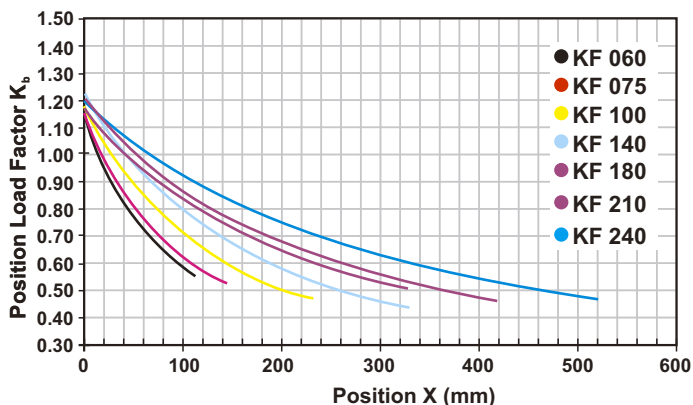

If radial force F_{2r} is not exerted on the center of the output shaft $X < 1/2 L$ or $X > 1/2 L$, the permitted radial and axial loads can be calculated by the position load factor K_b on the above diagram.

Permitted radial load F_{2r} on center of output shaft. $X = 1/2 L$ for various output speeds.

(A) Permitted loading values on the output shaft. Please refer to P. 16 glossary.

KF Dimension (Spiral Bevel)

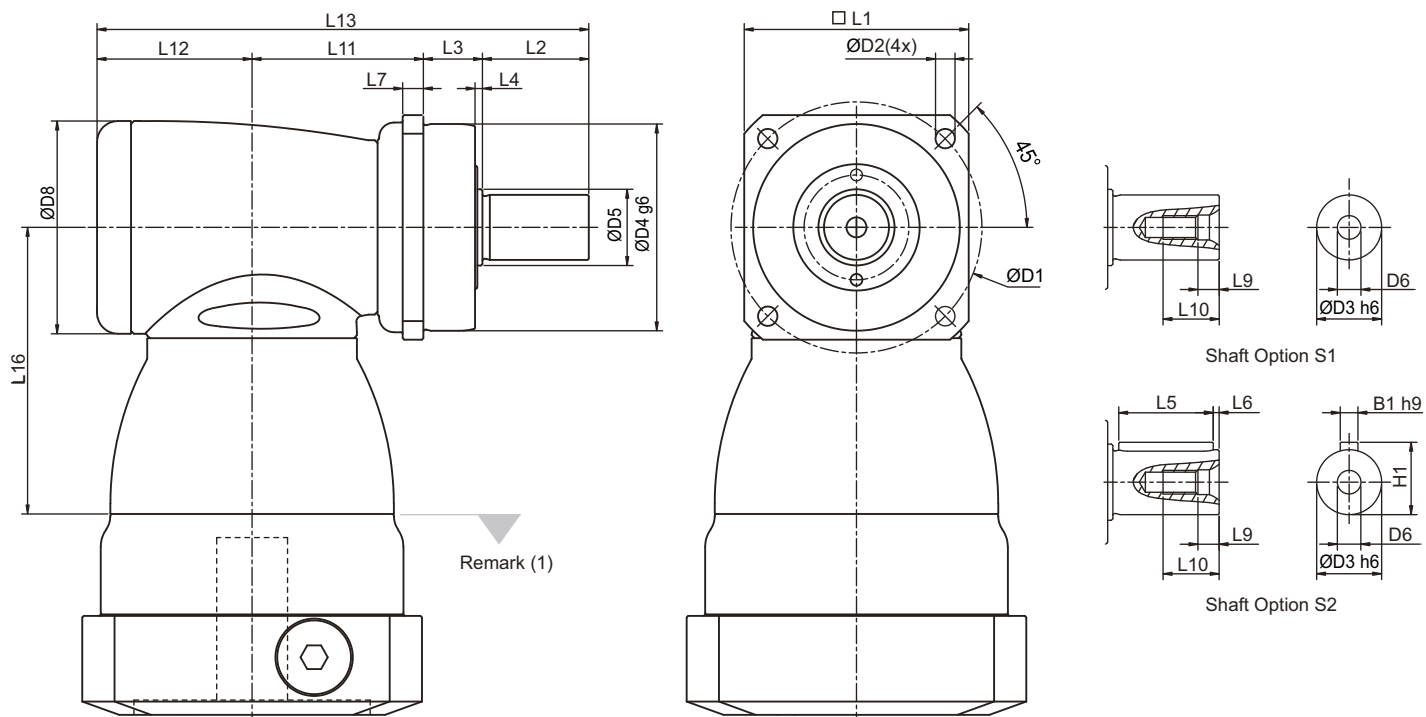

Dimension	KF 060	KF 075	KF 100	KF 140	KF 180	KF 210	KF 240
	1-stage	1-stage	1-stage	1-stage	1-stage	1-stage	1-stage
D1	68	85	120	165	215	250	290
D2	5.5	6.6	9	11	13.5	17	17
D3 h6	16	22	32	40	55	75	85
D4 g6	60	70	90	130	160	180	200
D5	18.5	25.8	36.8	55.2	69.2	82.2	92.2
D6	M5X0.8P	M8X1.25P	M12X1.75P	M16X2P	M20X2.5P	M20X2.5P	M20X2.5P
D8	64	72	92	116	156	195	240
L1	62	76	101	141	182	215	245
L2	28	36	58	82	82	105	130
L3	20	20	30	30	30	38	40
L4	2	2.5	3	3	3	3	3
L5	25	32	50	63	70	90	125
L6	2	2	4	5	6	7	3
L7	6	7	10	12	15	17	20
L9	4.8	7.2	10	12	15	15	15
L10	12.5	19	28	36	42	42	42
L11	50	58	67.5	88	127	131.5	169
L12	46.5	52.5	61.5	76	97.5	105.5	141
L13	144.5	166.5	217	276	336.5	380	480
L16	81.5	97	113.5	147.5	196.5	229	260
B1 h9	5	6	10	12	16	20	22
H1	18	24.5	35	43	59	79.5	90

(1) Dimensions are related to motor interface. Please contact APEX for details.

SHRINK DISC POWER LOCK

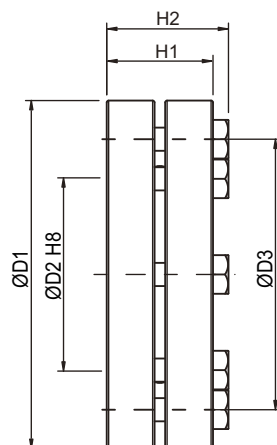

SHRINK DISC POWER LOCK

Model No.	Dimension	D1	D2	D3	H1	H2	Screw ⁽¹⁾	T _A ⁽²⁾	J	Order code
							No. x Type	(Nm)	(kg.cm ²)	
KF 060	SSD-d18xdw15	44	18	30	15	18.5	5 x M5	4	0.4	SSD-18
KF 075	SSD-d24xdw20	50	24	36	19.5	23	6 x M5	4	0.8	SSD-24
KF 100	SSD-d36xdw30	72	36	52	23.5	27.5	5 x M6	12	3.9	SSD-36
KF 140	SSD-d50xdw40	90	50	70	27.5	31.5	8 x M6	12	11.2	SSD-50
KF 180	SSD-d68xdw55	115	68	86	30.5	34.5	10 x M6	12	30.9	SSD-68

(1) 10.9 Class, DIN 931

(2) Tightening Torque

Selection of the optimum gearbox

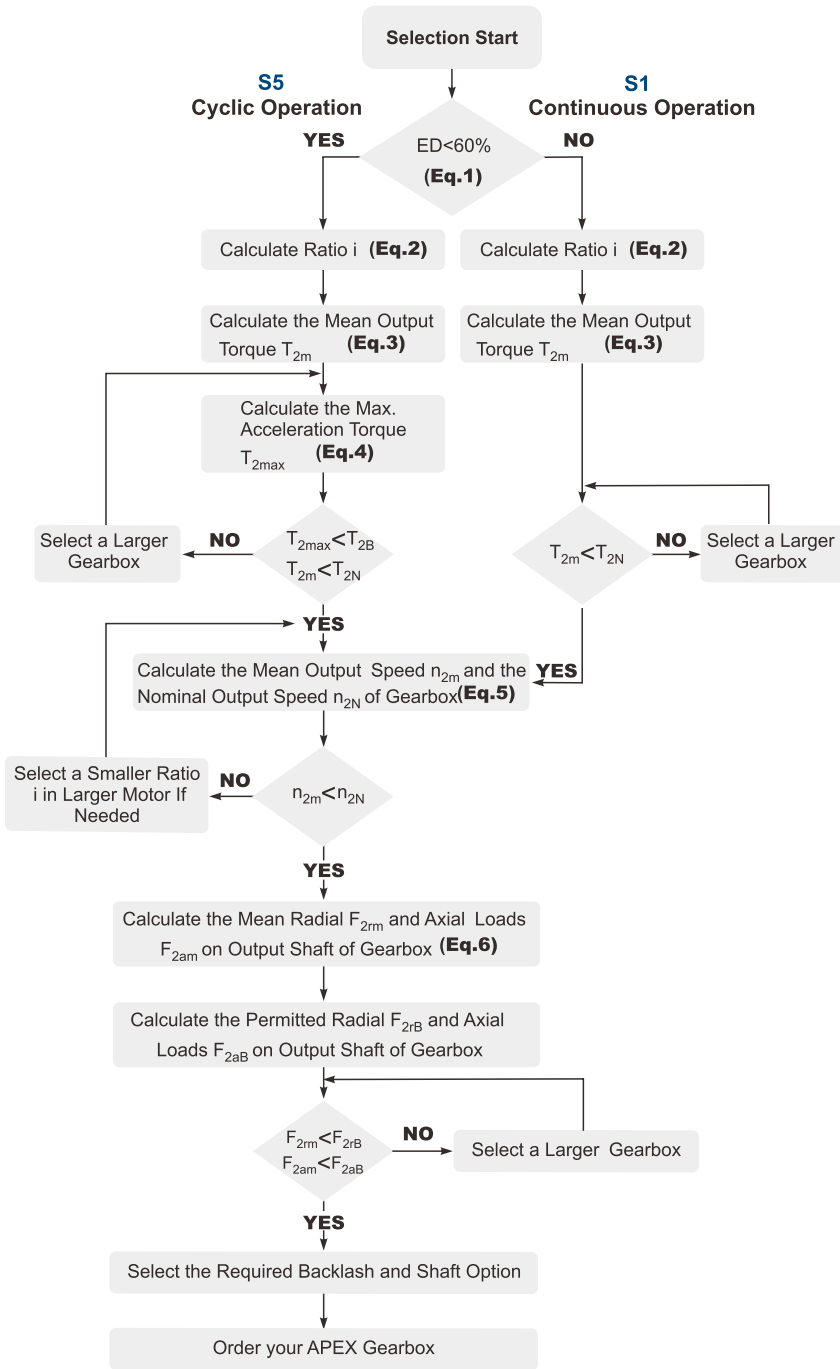

Recommended (for S5 Cycle Operation)

The general design is given for

$$\frac{J_L}{i^2} \leq 4 \times J_m$$

The optimal design is given for

$$\frac{J_L}{i^2} \cong J_m$$

J_L Load Inertia
 J_m Motor Inertia

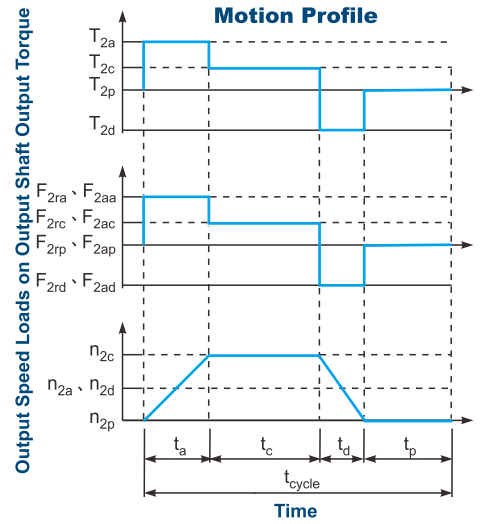

$$1. ED = \frac{t_a + t_c + t_d}{t_{cycle}} \times 100\% .$$

Index : a. Acceleration, c. Constant,
 d. Deceleration, p. Pause **(Eq.1)**

$$2. i \cong \frac{n_m}{n_{work}}$$

n_m Output Speed of the Motor
 n_{work} Working Speed **(Eq.2)**

$$3. T_{2m} = \sqrt[3]{\frac{n_{2a} \times t_a \times T_{2a}^3 + n_{2c} \times t_c \times T_{2c}^3 + n_{2d} \times t_d \times T_{2d}^3}{n_{2a} \times t_a + n_{2c} \times t_c + n_{2d} \times t_d}}$$

(Eq.3)

$$4. T_{2max} = T_{mB} \times i \times K_s \times \eta$$

where K_s is

K_s	No. of Cycles / hr
1.0	0 ~ 1,000
1.1	1,000 ~ 1,500
1.3	1,500 ~ 2,000
1.6	2,000 ~ 3,000
1.8	3,000 ~ 5,000

T_{mB} Max. Output Torque of the Motor

$$\eta \text{ Efficiency of the Gearbox} \quad \text{(Eq.4)}$$

$$5. n_{2a} = n_{2d} = \frac{1}{2} \times n_{2c}$$

$$n_{2m} = \frac{n_{2a} \times t_a + n_{2c} \times t_c + n_{2d} \times t_d}{t_a + t_c + t_d}$$

$$n_{2N} = \frac{n_{1N}}{i} \quad \text{(Eq.5)}$$

$$6. F_{2rm} = \sqrt[3]{\frac{n_{2a} \times t_a \times F_{2ra}^3 + n_{2c} \times t_c \times F_{2rc}^3 + n_{2d} \times t_d \times F_{2rd}^3}{n_{2a} \times t_a + n_{2c} \times t_c + n_{2d} \times t_d}}$$

$$F_{2am} = \sqrt[3]{\frac{n_{2a} \times t_a \times F_{2aa}^3 + n_{2c} \times t_c \times F_{2ac}^3 + n_{2d} \times t_d \times F_{2ad}^3}{n_{2a} \times t_a + n_{2c} \times t_c + n_{2d} \times t_d}} \quad \text{(Eq.6)}$$

Glossary

Emergency Stop Torque T_{2NOT}	Nm	The Emergency Stop Torque is the maximum permitted torque at the output of gearbox. This may happen only occasionally and may not exceed 1,000 times during the whole service life.
Max. Acceleration Torque T_{2B}	Nm	Under the Cyclic Operation (S5), the Max. Acceleration Torque is the maximum torque which can be transmitted only briefly to the output of gearbox up to 1,000 cycles/hr.
No Load Running Torque	Nm	The No Load Running Torque is the min. torque to overcome the internal friction of a gearbox without loading*.
Nominal Input Speed n_{1N}	rpm	The Nominal Input Speed is the permitted input speed of gearbox by the Continuous Operation (S1) while the housing temperature does not exceed 90°C. This value is measured at environment temperature 25°C.
Max. Input Speed n_{1B}	rpm	The Max. Input Speed is the max. permitted input speed of gearbox by the Cyclic operation (S5). This value is measured at environment temperature 25°C and serves as the absolute limit of the gearbox.
Backlash	arcmin	<p>The Backlash is the maximum angular measurement between two teeth of gears when the transverse operation occurs (refer to Diagram 1). The arcmin is the measurement unit for the backlash. One arcmin equals 1/60 degree, symbolized as 1'.</p> <p style="text-align: right;">Diagram 1</p>
Torsional Rigidity	Nm/arcmin	<p>Torsional Rigidity is the quotient ($\Delta T / \Delta \theta$) between the applied torque and resulting torsion angle. This value indicates how much torque is needed on the gearbox to rotate the output shaft for 1 arcmin. The Torsional Rigidity can be determined by Hysteresis Curve.</p> <p>Hysteresis Curve When the input shaft is locked, increase torque at the output slowly up to T_{2B} in both directions and then release the torque gradually. According to the measured torque and torsion angle, a closed curve will be acquired as in the Diagram 2.</p> <p style="text-align: right;">Diagram 2</p>
Radial Load And Axial Load	N	<p>The permitted radial and axial loads on output shaft of the gearbox depend on the design of the gearbox supporting bearings.</p> <p>For more information, please refer to APEX website.</p> <p style="text-align: right;">F_{2r} Radial Load F_{2a} Axial Load</p>
Efficiency η	%	The transmission efficiency of the gears inside a gearbox (without friction).
Operating Temperature	°C	The Operating Temperature indicates the temperature of gearbox housing.
Degree of Protection		IP code stands for International Protection standard. The IP65 as example: the first IP number stands for protection degree against dust; the second IP number stands for protection against liquid.
Lubrication		APEX uses synthetic lubrication grease. Alternate greases are available, please contact APEX.
Running Noise	dB(A)	The Running Noise is measured depends on gearbox size, the ratio and the speed*. Higher speed usually induces higher noise level, while higher ratio induces lower noise level.
Moment of Inertia J_1	kg.cm ²	The Moment of Inertia J_1 is a measurement of the effort applied to an object to maintain its momentary condition at rest or rotating.
Breakaway Torque	Nm	The Breakaway Torque is the minimum torque to start the rotation from the input side of gearbox. A smaller size or a higher ratio gearbox requests less Breakaway Torque.
Back Driving Torque	Nm	The Back Driving Torque is the minimum torque to start the rotation from the output side of gearbox. A larger size or a higher ratio gearbox requires greater Back Driving Torque.

* This value is measured at environment temperature 25°C and the input speed 3,000 rpm. If the Nominal Input Speed n_{1N} of gearbox is lower than 3,000 rpm, this value is measured by that specific Nominal Input Speed.

Liability Disclaimer:

APEX DYNAMICS, INC. endeavors to ensure the accuracy and reliability of the data in catalog.

APEX accepts no liability, whether in any form, for any loss or damage arising from any inaccuracy or omissions of this catalog.

Note

Note



**APEX TAIWAN NORTH
ANDTEK AUTOMATION CO.,LTD**
TEL +886-02-82262655
13F-5, NO.2, Jian 8th Rd., Jhonghe Dist., New
Taipei City 235, TAIWAN
sales@andtek.com.tw
www.apexdyan.com



**APEX TAIWAN CENTRAL
ANDTEK AUTOMATION CO.,LTD**
TEL +886-04-23594286
9F-6, NO.925, Sec.4, Taiwan Blvd., Xitun Dist.
Taichung City 407, TAIWAN
sales@andtek.com.tw
www.apexdyan.com



**APEX TAIWAN SOUTH
MEN JENN ELECTRIC CO., LTD.**
TEL +886-06-2337332*6
NO.774, Zhonghua Rd., Yongkang Dist., Tainan
City 710, TAIWAN
menjenn@ms24.hinet.net
www.apexdyan.com



APEX TAIWAN INC. SHANGHAI
TEL +86-21-69220577
NO.128 ZHUHYING Road QINGPU Industry Area,
Shanghai, CHINA
sales@apexdyna.cn
www.apexdyan.cn



APEX DYNAMICS SHENZHEN, LTD.
TEL +86-755-84516325
NO. 1102A of D area, CFG mansion, Bao Yuan
Road, Bao' an District, Shenzhen, CHINA.
sales@szapexdyna.com
www.szapexdyna.com



APEX DYNAMICS BEIJING, LTD.
TEL +86-10-69570691
NO. 1, Yao Ping Road, Song Zhuang Town, Tongzhou
District, Beijing, CHINA.
bjapexdyna@163.com
www.bjapex.cn



CHONGQING APEX DYNAMICS CO., LTD.
TEL +86-23-67686860
406, Building 5, NO. 68, Jinyu Avenue, Beibu New
Area, Chongqing, CHINA
sales@cqapexdyna.com
www.apexdyna.com



APEX (XIAMEN) DYNAMICS TECHNOLOGY CO., LTD.
TEL +86-0592-720-5279
Unit B-3, 1F., NO. 129, Jingquan Road, Jimei District,
Xiamen, Fujian, CHINA
sales@xmapexdyan.com
www.xmapexdyna.com



APEX DYNAMICS USA, INC.
TEL +1-631-2449040
885 Marconi Avenue Ronkonkoma, NY 11779
U.S.A.
sales@apexdynamicsusa.com
www.apexdynamicsusa.com



APEX DYNAMICS KOREA INC
TEL +82-31-8179992
7-5, Aenigol-gil, Ilsandong-gu, Goyang-si, Gyeonggi-do,
Republic of Korea 10301
sales@apexdynakorea.co.kr
www.apexdynakorea.co.kr



APEX DYNAMICS JAPAN
TEL +88-092-4511202
1-3-46, Hamnichibasi, Hakata-ku, Fukuoka,
812-0897, JAPAN
sales@apexdyna.jp
www.apexdyna.jp



APEX DYNAMICS SINGAPORE PTE LTD
TEL +34-93-6562228
3 South Buona Vista Road, #05-15 & #06-15.
SINGAPORE 118136
sales@apexdyna.com.sg
www.apexdyna.com.sg



APEX DYNAMICS (THAILAND) CO., LTD.
TEL +66-2-326623
87 Soi Ladkrabang 30, Ladkrabang, Ladkrabang,
Bangkok 10520, Thailand
Apexthai2010@gmail.com
www.apexdyna.co.th



APEX DYNAMICS BV
TEL +31-492-509995
Churchillaan 101 5705 BK Helmond, NETHERLANDS
sales@apexdyna.nl
www.apexdyna.be



**APEX DYNAMICS
POLSKA SP. Z O.O.**
TEL +48-12-6304728
Ul. Krakowska 50, 32-083 Balice, Poland
sales@apexdyna.pl
www.apexdyna.pl



APEX DYNAMICS SPAIN, S.L.
TEL +34-93-6562290
Poligono Industrial Moli dels Freres, Calle C nº
12,08620-Sant Vicenç dels Horts, Barcelona, SPAIN
apexdyna@apexdyna.es
www.apexdyna.es



Big Diamond Trading Company LLC
TEL +968-94268885
2nd floor, Regus, Tamimah building, Al
Wattayah, Muscat, Oman
ar.gorji@diamondtradings.com



APEKS DINAMIK REDUKTOR DISLI SAN TIC AS
TEL +90-232-4589960
10053 SOKAK NO: 9 A.O.S.B. CIGLI- IZMIR- TURKEY
sales@apexdyna.com.tr
www.apexdyna.com.tr



APEX DYNAMICS AUSTRALIA PTY LTD.
TEL +613-95-852739
36 Taunton Drive, Cheltenham, Victoria 3192
AUSTRALIA
sales@apexdyna.com.au
www.apexdyna.com.au



APEX DYNAMICS (I) JV
TEL +91-9607927142
Shop No. 02, S. No. 100/5, Pune-Satara Highway,
Ambegaon Khurd, Pune-411046 Maharashtra, India
sales@apexdyna.co.in
www.apexdyna.co.in



APEX DYNAMICS FRANCE SAS
TEL +33-160-135097
11 - Burospace - 91570 - Bièvres, France
info@apexdyna.fr
www.apexdyna.fr



APEX DYNAMICS SWEDEN AB
TEL +46-75-2424444
Fredrikbergsgatan 2 SE-573 92 Tranås, SWEDEN
sales@apexdyna.se
www.apexdyna.se



PT.APEX DYNAMICS INDONESIA
TEL +62 21 2928 3681
Rukan Aralia Blok HY43 no.11, Harapan Indah II,
Bekasi - Jawa Barat, INDONESIA 17214
sales@apexdyna.co.id
www.apexdyna.co.id



APEX DYNAMICS GERMANY GMBH
TEL +49-7171 798069-0
Marie-Curie-Straße 25 D-73529 Schwäbisch Gmünd
werner.langer@apexdynamics.de
www.apexdynamics.de



APEX DYNAMICS CZECH S.R.O.
TEL +420-577-663877
tř. Tomáše Bati 1851 765 02 Otrokovice Česká
REPUBLIKA
info@apexdynaczech.cz
www.apexdynaczech.cz



APEX DYNAMICS РОССИЯ
TEL +7-495-2255452
TEL +7-495-6462422
г.Москва,ул. Южнопортовая, дом 7, строение
"С", 3-й этаж
info@apexdynarussia.ru
www.apexdynarussia.ru



APEX DYNAMICS MIDLANDS LTD
TEL +44-0121-737-1170
Heath House, Cheadle Rd, Uttoxeter,
ST14 7BY, UK
mikeg@apexdynauk.com
www.apexdynauk.com



APEX DYNAMICS SWITZERLAND AG
TEL +41-55-4517020
Obergasse 40, CH-8854 Galgenen, Switzerland
info@apexdyna.ch
www.apexdyna.ch



APEX DYNAMICS MOTION (M) SDN BHDTEL
TEL +60 7237 1055
Block A1-2, #35-03, Mercu 1 Jalan Tanjung Puteri 1,
R & F Tanjung Puteri, Johor Bahru 80300, Johor.
sales@apexdyna.com.sg
www.apexdyna.com.sg



APEX DYNAMICS BRAZIL
TEL +55-47-30298700
Rua Senador Petrônio Portela, 47-Bloco 5, Zona
Industrial Norte-CEP 89218-575-Joinville (SC)
luciano@neoyama.com.br
adriano.tuarte@neoyama.com.br
www.neoyama.com.br



APEX DYNAMICS ITALY SRL
TEL +39 02 36634521
VIA E. DE AMICIS, 2-20091 BRESSO (MI)
info@apexdynamics.it
www.apexdynamics.it



APEX DYNAMICS AUSTRIA GmbH
TEL +43 720788416
Dr. Hans-Lechner-Strasse 6,
5071 Wals-Siezenheim
info@apexdynamics.at
www.apexdynamics.at



UAB "APEKSO DINAMIKA"
TEL +370 52078165
Medaus g. 28A,
Medininuku k., Vilnius r. Sav.
LT-13192
info@apexdyna.lt



APEX DYNAMICS DENMARK
TEL +45 73121260
Grundtvigs Allé 165, 6400
Sønderborg, Denmark
sales@apexdyna.dk
www.apexdyna.dk



APEX DYNAMICS ISRAEL
TEL +972-3-6470471
17 Hamefalsim St., Kiryat Arye,
Petach-Tikva 4951447
Sales@apexdynamics.co.il
www.apexdynamics.co.il



APEX DYNAMICS SLOVAKIA S.R.O.
TEL +421919400476
Trenčianska cesta 887/52, 957 01
Bánovce nad Bebravou, Slovak republic
office@apexdyna.sk
www.apexdyna.sk



APEX DYNAMICS, INC.

No10. Keyuan 3rd RD.Situn District, Taichung City 40763, Taiwan (R.O.C)

Tel:886-4-24650219 | Fax:886-4-24650118

sales@apexdyna.com | <http://www.apexdyna.com>

APEX-2022-11-K SERIES-1.0-TWN

Printed in Taiwan

