

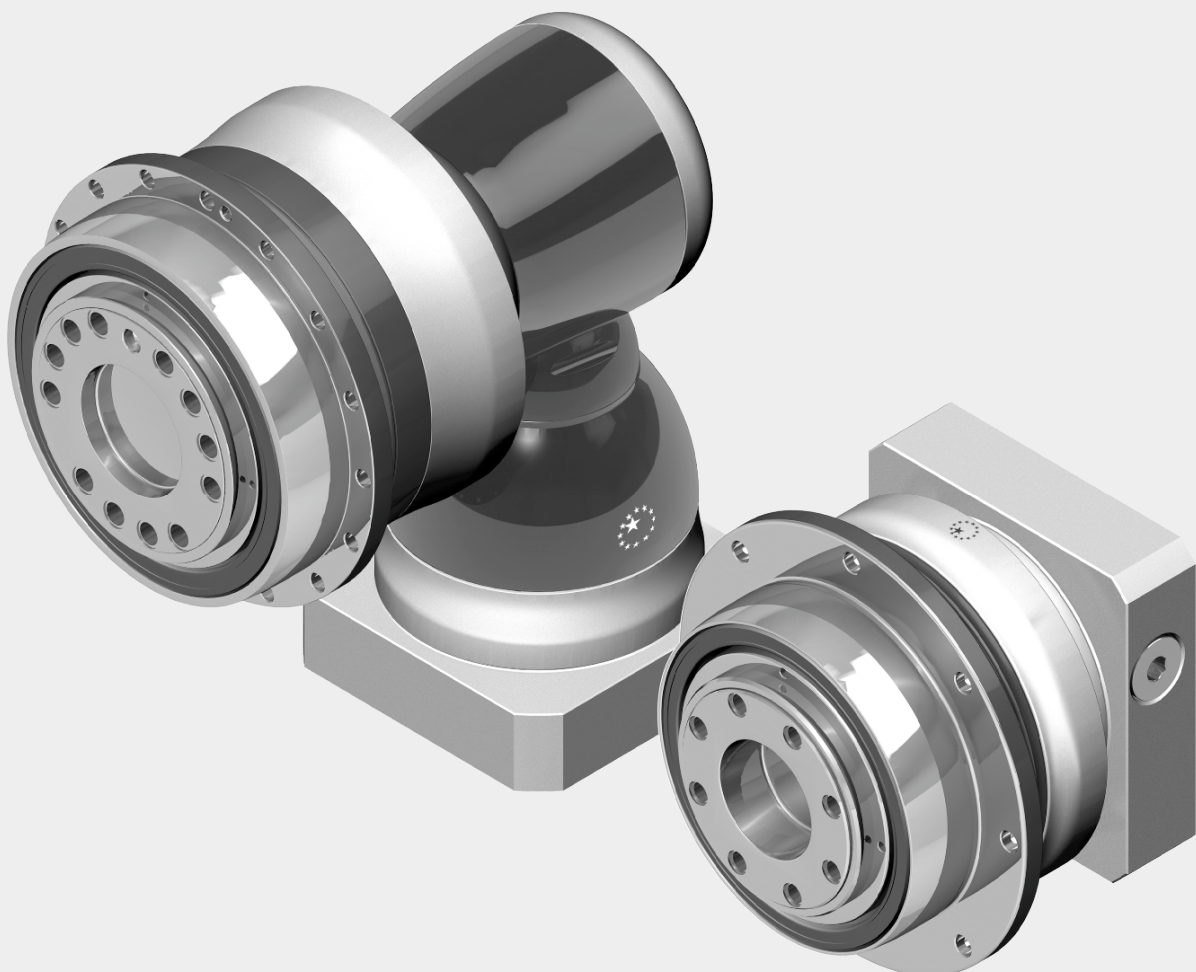

APEX DYNAMICS, INC.

**NEW GENERATION
PLANETARY GEARBOX**

MD / MDK Series



Gearbox Series - MD / MDK

► Features:

High Rigidity

High Torque

High Precision

High Efficiency

Persistence of Low Backlash

Long Life-Time

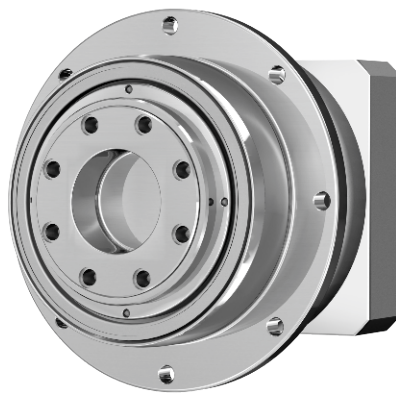

Ordering Code - MD / MDK Series

MD090	—	005⁽¹⁾	/	MOTOR
MDS090	—	005⁽¹⁾	— SI	
MDK090	—	005⁽¹⁾	/	MOTOR
MDKA285⁽³⁾				Motor Type
MDKB090⁽³⁾				Shaft Type
				Ratio
				Gearbox Size

MDS is the MD version with input “SHAFT” instead of input “HUB”⁽⁴⁾

Gearbox Size

MD 064 / 090 / 110 / 140 / 200 / 255 / 285 / 355 / 450

MDK 064 / 090 / 110 / 140 / 200 / 255 / 285 / 355 / 450

Ratio⁽²⁾

MD (1 Stg.) 4 / 5 / 7 / 10

(2 Stg.) 16 / 20 / 21 / 25 / 28 / 31 / 35 / 40 / 46 / 50 / 61 / 70 / 91 / 100

MDK (2 Stg.) 12 / 15 / 16 / 20 / 25 / 28 / 35 / 40 / 49 / 50 / 70 / 100

MDKA (3 Stg.) 100 / 125 / 140 / 175 / 200 / 250 / 350 / 500 / 700 / 1,000

MDKB (3 Stg.) 64 / 84 / 100 / 125 / 140 / 175 / 200 / 250 / 280 / 350 / 400 / 500 / 700 / 1,000

MDK (4 Stg.) 1,225 / 1,400 / 1,750 / 2,000 / 2,800 / 3,500 / 5,000 / 7,000 / 10,000

MDKC 4 / 5 / 7 / 8 / 10 / 21 / 31 / 46 / 61 / 91

Shaft Type : SI = Smooth input shaft

S2 = Input shaft with key

Motor Type

Manufacturer and Model

(1) Ratio (I=N_{in}/N_{out}).

(2) Please refer to the specifications for the ratios provided in each series.

(3) Please refer to page 06.

(4) The customization detail please contact with APEX sales.



©2020 by APEX DYNAMICS, INC.

APEX DYNAMICS, INC. reserves modification and copyrights of all technical specifications, illustrations and drawings in this catalog in allowance for continuous products development and advancement.

For the newest data and information, please visit <http://www.apexdyna.com/>

Performance - MD Gearbox

Model No.	Stage	Ratio ⁽¹⁾	MD064	MD090	MD110	MD140	MD200	MD255	MD285	MD355	MD450	
Nominal Output Torque T_{2N} By n_{1N}	1	4	100	205	380	765	1,415	2,190	4,035	-	-	
		5	85	185	325	660	1,225	1,905	3,505	6,250	12,105	
		7	60	135	260	515	980	1,530	2,530	5,045	10,260	
		10	24	55	160	315	700	1,070	1,810	3,345	7,160	
	2	16	85	195	385	805	1,485	2,295	4,215	-	-	
		20	80	190	370	795	1,495	1,990	3,660	-	-	
		21	90	195	345	700	1,295	2,005	3,685	6,525	12,495	
		25	90	195	345	700	1,295	2,005	3,685	-	-	
		28	60	180	345	755	1,510	2,335	4,290	-	-	
		31	60	135	280	560	1,050	1,620	2,590	5,280	10,595	
		35	75	195	350	705	1,310	2,030	3,725	-	-	
		40	40	96	220	615	1,260	2,360	4,280	-	-	
		46	24	55	160	335	660	1,005	1,700	3,400	7,125	
		50	50	120	275	715	1,325	2,050	3,765	-	-	
		61	60	135	285	585	1,095	1,670	2,675	5,445	10,895	
		70	60	135	285	585	1,095	1,670	2,675	-	-	
		91	24	55	160	345	660	1,005	1,700	3,400	7,000	
		100	24	55	160	345	660	1,005	1,700	-	-	
Emergency Stop Torque T_{2NOT}	Nm	1,2	4~100	3 times T_{2N}								
Max. Acceleration Torque T_{2B}	Nm	1,2	4~100	1.5 times T_{2N}								
No Load Running Torque ⁽³⁾	Nm	1	4~10	0.45	0.7	1.4	3.5	7	11	14	25	40
		2	16~100	0.2	0.3	0.6	1.3	2.2	3.5	4.5	13	21
Backlash ⁽²⁾	arcmin	1	4~10	≤ 3	≤ 3	≤ 3	≤ 3	≤ 3	≤ 3	≤ 3	≤ 3	≤ 3
		2	16~100	≤ 4	≤ 4	≤ 4	≤ 4	≤ 4	≤ 4	≤ 4	≤ 4	≤ 4
Torsional Rigidity	Nm/arcmin	1,2	4~100	8	22	60	115	395	650	1,050	2,850	5,700
Nominal Input Speed n_{1N}	rpm	1	4~10	5,000	3,600	3,600	3,000	2,700	2,400	2,100	1,500	1,000
		2	16~100	5,000	4,600	4,600	4,000	3,700	3,400	3,100	2,500	2,000
Max. Input Speed n_{1B}	rpm	1	4~10	7,000	6,000	6,000	5,000	4,500	4,000	3,500	3,000	2,500
		2	16~100	7,000	7,000	7,000	6,000	5,500	5,000	4,500	4,000	3,500
Max. Axial Load F_{2a} ⁽⁴⁾	N	1,2	4~100	1,690	2,220	4,070	8,530	17,000	26,900	39,200	101,500	143,700
Max. Tilting Moment M_{2K} ⁽⁴⁾	Nm	1,2	4~100	120	280	480	1,310	3,530	5,920	9,230	29,100	63,300
Operating Temp	°C	1,2	4~100	-10° C ~ 90° C								
Degree of Gearbox Protection		1,2	4~100	IP67								
Lubrication		1,2	4~100	Synthetic lubrication grease								
Mounting Position		1,2	4~100	All directions								
Running Noise ⁽³⁾	dB(A)	1	4~10	≤ 58	≤ 59	≤ 64	≤ 65	≤ 66	≤ 66	≤ 66	≤ 68	≤ 70
		2	16~100	≤ 58	≤ 59	≤ 60	≤ 63	≤ 66	≤ 66	≤ 66	≤ 68	≤ 70
Efficiency η	%	1	4~10	≥ 97%								
		2	16~100	≥ 94%								

(1) Ratio ($i = N_{in} / N_{out}$).

(2) Backlash is measured at 2% of Nominal Output Torque T_{2N} .

(3) The dB values are measured by gearbox with ratio 10 (1-stage) or ratio 100 (2-stage), no loading at 3,000 RPM or at the respective Nominal Input Speed by bigger model size.

By lower ratio and/or higher RPM, the noise level could be 3 to 5 dB higher.

(4) Applied to the output flange center at 100 rpm.

(5) Continuous operation is not recommended.

Inertia - MD Gearbox

Model No.	MD064		MD090		MD110		MD140		MD200		MD255		MD285		MD355		MD450	
	∅ ^(A) (C3)		1-st.	2-st.	1-st.	2-st.	1-st.	2-st.	1-st.	2-st.	1-st.	2-st.	1-st.	2-st.	1-st.	2-st.	1-st. ^(B)	2-st. ^(B)
8	kg.cm ²		-	0.1	-	-	-	-	-	-	-	-	-	-	-	-	-	-
11			0.17	0.16	-	0.17	-	-	-	-	-	-	-	-	-	-	-	-
14			0.21	0.2	0.53	0.21	-	0.53	-	-	-	-	-	-	-	-	-	-
19			0.63	-	0.68	0.63	1.83	0.68	-	1.83	-	-	-	-	-	-	-	-
24			-	-	4.52	-	5.04	4.52	5.63	5.04	-	5.63	-	-	-	-	-	-
28			-	-	-	-	6.33	-	7.18	6.33	-	7.18	-	-	-	-	-	-
32			-	-	-	-	8.73	-	10.1	8.73	12.63	10.1	-	12.63	-	-	-	-
35			-	-	-	-	14.04	-	15.54	14.04	17.75	15.54	17.35	17.75	28.18	20.8	-	-
38			-	-	-	-	19.05	-	21.32	19.05	23.26	21.32	23.61	23.26	28.18	27.05	-	23.6
42			-	-	-	-	-	-	23.2	-	25.4	23.2	25.5	25.4	30.52	28.95	-	25.37
48			-	-	-	-	-	-	56.07	-	61.02	56.07	61.22	61.02	66.85	64.66	-	89.35
55			-	-	-	-	-	-	-	-	88.51	-	88.86	-	94.91	-	-	102
60			-	-	-	-	-	-	-	-	-	-	-	117.73	-	-	-	117.75

(A) ∅ = Input shaft diameter.

(B) For 1-st. of MD355/MD450 please contact APEX for details.

Flange Shaft - MD

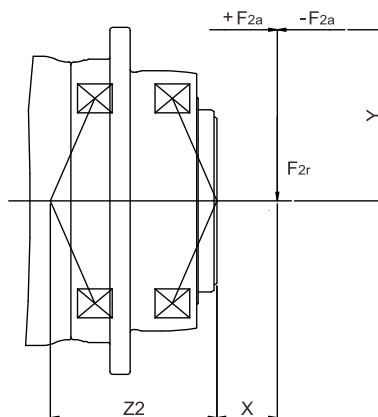
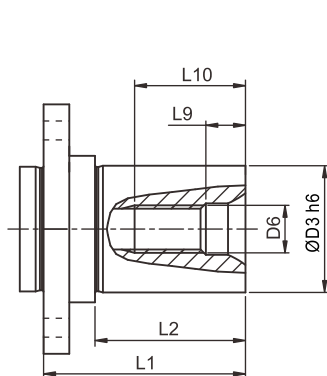

$$M_{2K} = \frac{F_{2a} * Y + F_{2r} * (X + Z_2)}{1000}$$

M_{2K} : [Nm]

F_{2a}, F_{2r} : [N]

X, Y, Z₂ : [mm]

Dimension	L1	L2	D3 h6	D6	L9	L10	Order Code
MD064	33	23	16	M5	4.8	12.5	FLS-AH064-S16
			22	M8	7.2	19	FLS-AH064-S22
MD090	41	30	22	M8	7.2	19	FLS-AH090-S22
			32	M12	10	28	FLS-AH090-S32
MD110	51	38	32	M12	10	28	FLS-AH110-S32
			40	M16	12	36	FLS-AH110-S40
MD140	54	38	40	M16	12	36	FLS-AH140-S40
			55	M20	15	42	FLS-AH140-S55
MD200	73	52	55	M20	15	42	FLS-AH200-S55
			75	M20	15	42	FLS-AH200-S75
MD255	150	123	90	M24	18	50	FLS-AH255-S90

Note: Dimensions are related to gearbox flange interface.

M2K

MD / MDK	064	090	110	140	200	255	285	355	450
Z ₂ [mm]	63.7	84.5	106.2	90	122.8	133.2	175.5	220.6	275.3

Note : Applied to the output flange center at 100 rpm

Dimension - MD Gearbox

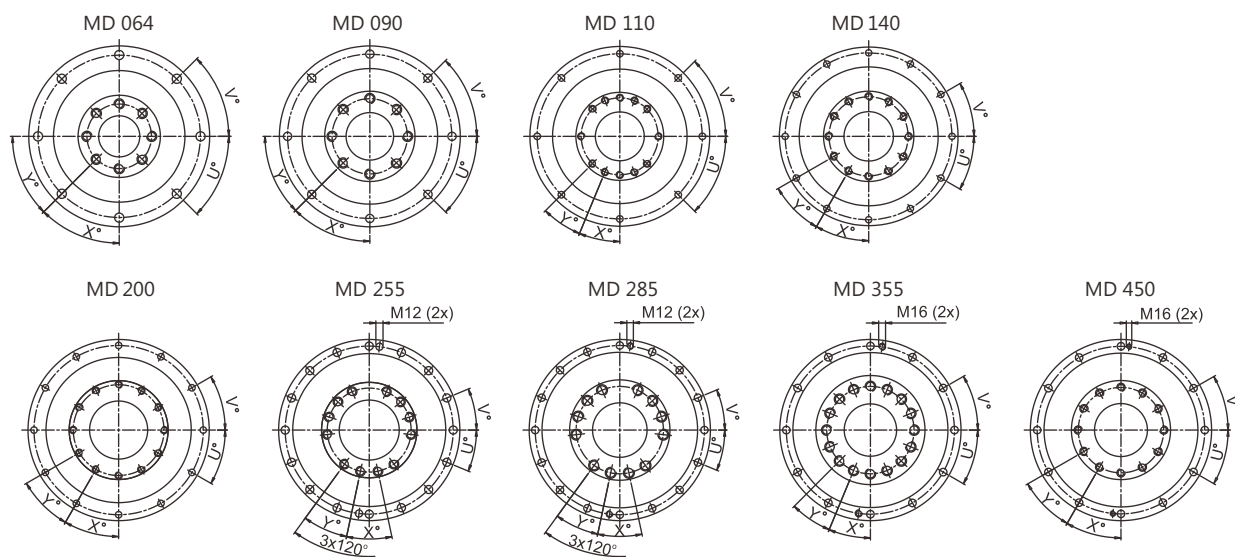
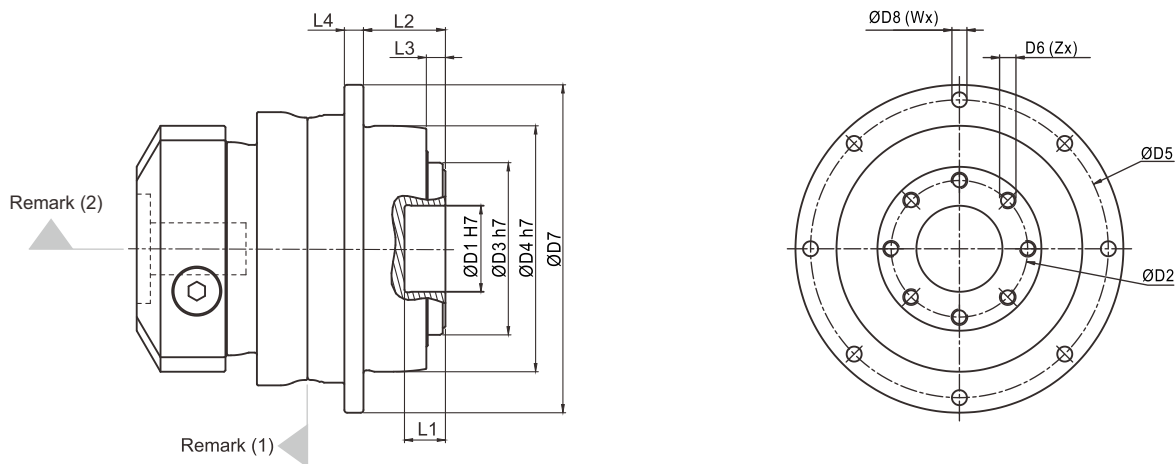

Dimension		MD064	MD090	MD110	MD140	MD200	MD255	MD285	MD355	MD450
D1	H7	20	31.5	40	50	80	100	100	120	155
D2		31.5	50	63	80	125	140	160	200	250
D3	h7	40	63	80	100	160	180	200	250	315
D4	h7	64	90	110	140	200	255	285	355	450
D5		79	109	135	168	233	280	310	385	490
D6 x Pitch x Deep		M5x0.8Px8	M6x1Px10	M6x1Px11	M8x1.25Px15	M10x1.5Px20	M16x2Px25	M20x2.5Px31	M24x3Px32	M30x3.5Px40
D7		88	120	147	180	249.5	302	332	415	530
D8		4.5	5.5	5.5	6.6	9	13.5	13.5	17.5	22
L1		8	15	15	15	16	16	16	35	24
L2		19.5	30	29	38	50	66	75	80	85
L3		4	7	7	7.5	8.5	13.5	16.5	20	20
L4		5	7	8	10	12	18	20	45	60
X in Degree		45	45	22.5	30	30	24	24	22.5	30
Y in Degree		45	45	22.5	30	30	24	24	22.5	30
Z		8	8	12	12	12	12	12	16	12
U in Degree		45	45	45	30	30	22.5	22.5	30	30
V in Degree		45	45	45	30	30	22.5	22.5	30	30
W		8	8	8	12	12	16	16	12	12

(1) Dimensions are related to motor interface. Please contact APEX for details.

(2) As alternative to input "HUB", input "SHAFT" is also available, please find in page 06.

Dimension - MDS (Input Shaft as Option)

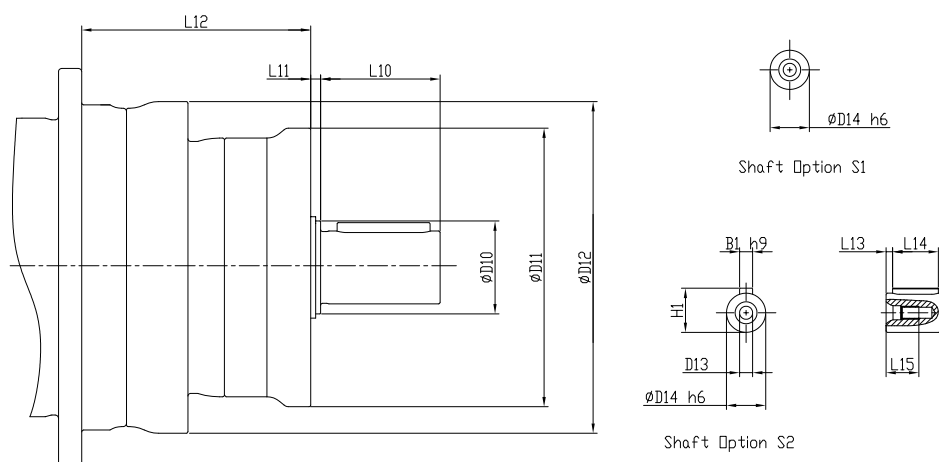

Dimension	Stage	MDS064	MDS090	MDS100	MDS140	MDS200	MDS255	MDS285	MDS355	MDS450
D10	1	20	28	35	50	70	70	75	-	-
	2	17	20	28	35	50	70	70	75	75
D11	1	68	84	93	118	178	180	225	-	-
	2	60	68	84	93	118	178	180	225	225
D12	1,2	76	100	132	160	232	262	301.5	362	466
D13	1	M4x0.7P	M8x1.25P	M10x1.5P	M12x1.75P	M16x2P	M20x2.5P	M20x2.5P	-	-
	2	M3x0.5P	M4x0.7P	M8x1.25P	M10x1.5P	M12x1.75P	M16x2P	M20x2.5P	M20x2.5P	M20x2.5P
D14 h6	1	12	22	28	38	45	55	60	-	-
	2	10	12	22	28	38	45	55	55	60
L10	1	18	36	42	58	82	82	105	-	-
	2	15	18	36	42	58	82	82	82	105
L11	1	3	3	4	5	10	11	11	-	-
	2	3	3	3	4	5	10	11	11	11
L12	1	57.5	69	88	107.5	151.5	149	216	-	-
	2	73	85	110	136	174.5	210	255.5	278.5	374
L13	1	2	3	5	5	5	6	2.5	-	-
	2	2	2	3	5	5	5	6	6	2.5
L14	1	14	28	32	40	65	70	100	-	-
	2	10	14	28	32	40	65	70	70	100
L15	1	10	19	22	28	36	42	42	-	-
	2	9	10	19	22	28	36	42	42	42
B1 h9	1	4	6	8	10	14	16	18	-	-
	2	3	4	6	8	10	14	16	16	18
H1	1	13.5	24.5	31	41	48.5	59	64	-	-
	2	11.2	13.5	24.5	31	41	48.5	59	59	64

Performance - MDS (Input Shaft as Option)

Model No.		Stage	Ratio ⁽¹⁾	MDS064	MDS090	MDS100	MDS140	MDS200	MDS255	MDS285	MDS355	MDS450
Max. Radial Load $F_{1rB}^{(2)}$	N	1	4~10	460	600	800	1,025	2,720	2,940	3,620	-	-
		2	16~100	275	460	600	800	1,025	2,720	2,940	3,240	3,620
Max. Axial Load $F_{1aB}^{(2)}$	N	1	4~10	230	300	400	512	1,360	1,470	1,810	-	-
		2	16~100	137	230	300	400	512	1,360	1,470	1,620	1,810
Moment of Inertia	Kg·cm ²	1	4~10	0.19	0.62	1.78	7.72	44.73	55.41	133.12	-	-
		2	16~100	0.06	0.19	0.62	1.78	7.72	44.73	53.41	133.12	111.15

(1) Ratio ($i = N_{in} / N_{out}$).

(2) Applied to the input shaft center at 1000 rpm

(3) The customization detail please contact with APEX sales.

MDK Gearbox Structure

MDK Structure

(I) MDK-2 Stage

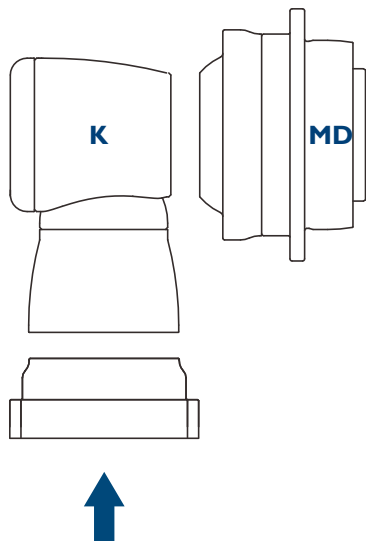

(II) MDK-3 Stage

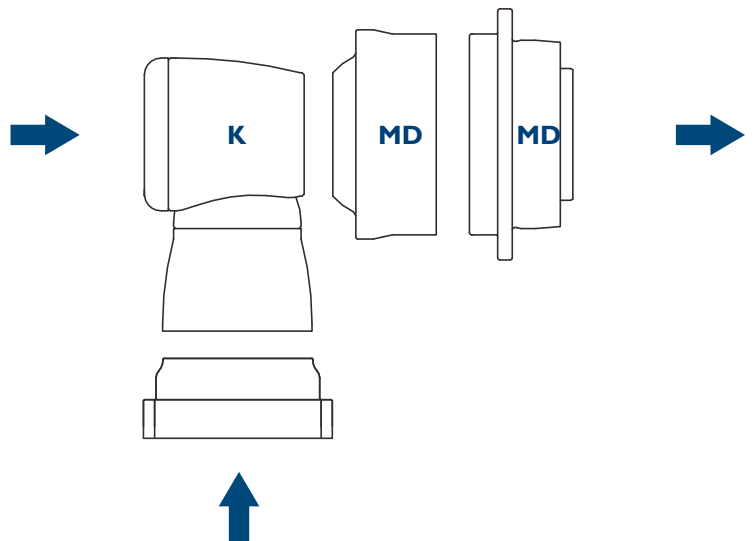

(III) MDK-3 Stage

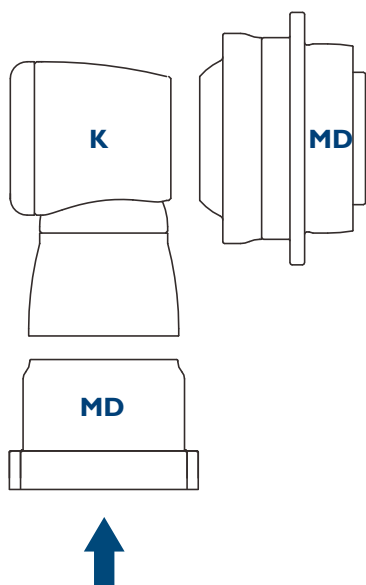

(IV) MDK-4 Stage

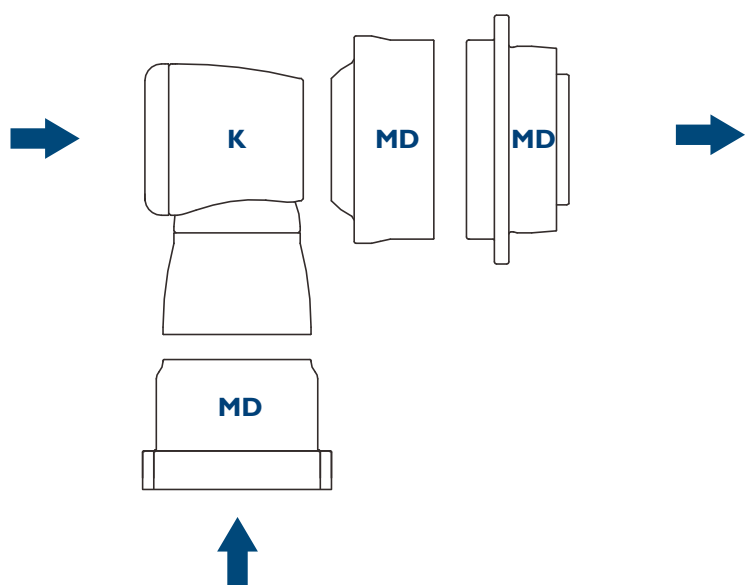

Performance - MDK (2 Stage) Gearbox

Model No.	Stage	Ratio ⁽¹⁾	MDK064	MDK090	MDK110	MDK140	MDK200	MDK255	MDK285	MDK355	
Nominal Output Torque T_{2N} By n_{IN}	Nm	2	12	80	195	365	805	1,495	1,680	3,280	-
			15	-	-	-	-	-	2,005	3,675	6,510
			16	80	185	350	775	1,510	1,680	3,280	-
			20	75	180	335	750	1,520	1,780	3,710	6,570
			25	80	195	350	710	1,320	1,775	3,735	6,615
			28	75	170	320	720	1,465	1,560	3,000	-
			35	80	190	355	715	1,330	1,950	3,750	6,675
			40	72	160	305	680	1,405	1,440	2,400	-
			49	63	135	290	585	1,105	1,680	2,685	5,470
			50	85	185	345	725	1,345	1,800	3,000	5,500
70	63	135	295	600	1,130	1,710	2,730	5,560			
100	24	57	160	350	605	915	1,590	3,315			
Emergency Stop Torque T_{2NOT}	Nm	2	12~100	2 times T_{2N}							
Max. Acceleration Torque T_{2B}	Nm	2	12~100	1.5 times T_{2N}							
No Load Running Torque ⁽³⁾	Nm	2	12~100	1	1.3	2	3.1	6	13	16	20
Backlash ⁽²⁾	arcmin	2	12~100	≤ 4	≤ 4	≤ 4	≤ 4	≤ 4	≤ 4	≤ 4	≤ 4
Torsional Rigidity	Nm/arcmin	2	12~100	12	27	56	112	389	642	1,275	2,500
Nominal Input Speed n_{IN}	rpm	2	12~100	3,000	3,000	2,800	2,700	2,200	2,100	2,000	1,600
Max. Input Speed n_{IB}	rpm	2	12~100	6,000	6,000	6,000	4,500	4,500	4,000	3,000	2,500
Max. Axial Load F_{2a} ⁽⁴⁾	N	2	12~100	1,690	2,220	4,070	8,530	17,000	26,900	39,200	101,500
Max. Tilting Moment M_{2k} ⁽⁴⁾	Nm	2	12~100	120	280	480	1,310	3,530	5,920	9,230	29,100
Operating Temp	°C	2	12~100	-10° C ~ 90° C							
Degree of Gearbox Protection		2	12~100	IP67							
Lubrication		2	12~100	Synthetic lubrication grease							
Mounting Position		2	12~100	All directions							
Running Noise ⁽³⁾	dB(A)	2	12~100	≤ 64	≤ 66	≤ 68	≤ 68	≤ 70	≤ 70	≤ 72	≤ 74
Efficiency η	%	2	12~100	≥ 94%							

(1) Ratio ($i = N_{in} / N_{out}$).

(2) Backlash is measured at 2% of Nominal Output Torque T_{2N} .

(3) The dB values are measured by gearbox with ratio 100 (2-stage), no loading at 3,000 RPM or at the respective Nominal Input Speed by bigger model size.

By lower ratio and/or higher RPM, the noise level could be 3 to 5 dB higher.

(4) Applied to the output flange center at 100 rpm.

(5) Continuous operation is not recommended.

Inertia - MDK (2 Stage) Gearbox

Model No.	MDK064	MDK090	MDK110	MDK140	MDK200	MDK255	MDK285	MDK355
8	0.1	-	-	-	-	-	-	-
11	0.17	0.18	-	-	-	-	-	-
14	0.21	0.5	0.52	-	-	-	-	-
19	-	0.65	1.69	1.71	-	-	-	-
24	-	-	4.89	5.05	6.92	-	-	-
28	-	-	-	6.55	6.98	-	-	-
32	-	-	-	9.47	10.18	10.18	-	-
35	-	-	-	14.91	15.21	15.21	15.68	-
38	-	-	-	20.69	20.7	20.7	21.69	23.46
42	-	-	-	-	22.83	22.83	23.59	25.28
48	-	-	-	-	58.45	58.45	59.3	61.61
55	-	-	-	-	-	-	-	89.67

(A) \varnothing = Input shaft diameter.

Dimension - MDK (2 Stage) Gearbox (Ratio i =12~100)

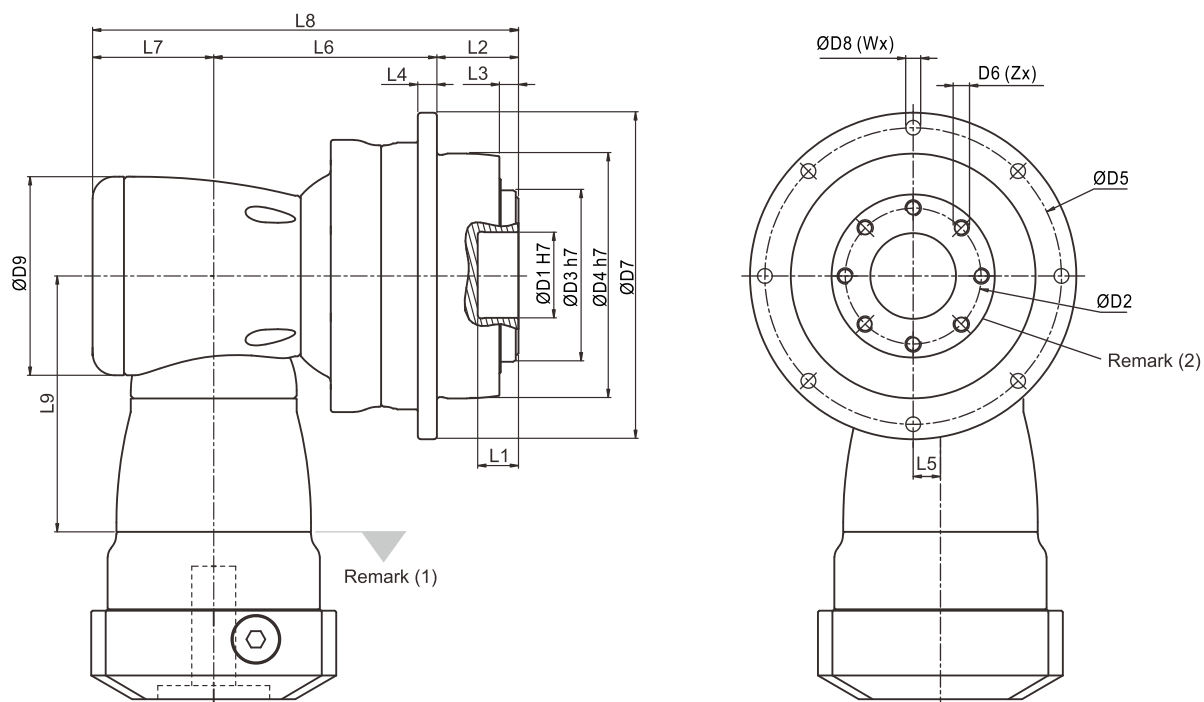

Dimension	MDK064	MDK090	MDK110	MDK140	MDK200	MDK255	MDK285	MDK355
D1 H7	20	31.5	40	50	80	100	100	120
D2	31.5	50	63	80	125	140	160	200
D3 h7	40	63	80	100	160	180	200	250
D4 h7	64	90	110	140	200	255	285	355
D5	79	109	135	168	233	280	310	385
D6 x Pitch x Deep	M5x0.8Px8	M6x1Px10	M6x1Px11	M8x1.25Px15	M10x1.5Px20	M16x2Px25	M20x2.5Px31	M24x3Px32
D7	88	120	147	180	249.5	302	332	415
D8	4.5	5.5	5.5	6.6	9	13.5	13.5	17.5
D9	73	94	116	163	210	210	255	300
L1	8	15	15	15	16	16	16	35
L2	19.5	30	29	38	50	66	75	80
L3	4	7	7	7.5	8.5	13.5	16.5	20
L4	5	7	8	10	12	18	20	45
L5	10	13	17	25	31	31	36	43
L6	87	90.5	114	147.5	175	191.5	249.5	290
L7	44.5	53	68.3	89	115	115	131	165
L8	151	173.5	211.3	274.5	340	372.5	455.5	535
L9	94	114.5	129	173.5	228	228	265.5	294.5
X in Degree	45	45	22.5	30	30	24	24	22.5
Y in Degree	45	45	22.5	30	30	24	24	22.5
Z	8	8	12	12	12	12	12	16
U in Degree	45	45	45	30	30	22.5	22.5	30
V in Degree	45	45	45	30	30	22.5	22.5	30
W	8	8	8	12	12	16	16	12

(1) Dimensions are related to motor interface. Please contact APEX for details.

(2) Refer to the MD series (Page 05) for flange interface.

Performance - MDKA (3 Stage) Gearbox

Model No.	Stage	Ratio ⁽¹⁾	MDKA285	MDKA355	MDKA450	
Nominal Output Torque T_{2N} By n_{1N}	Nm	3	100	3,875	6,815	12,930
			125	3,900	6,855	12,995
			140	3,910	6,870	13,030
			175	3,930	6,910	13,090
			200	3,945	6,930	12,000
			250	3,970	6,970	13,195
			350	4,000	7,030	12,650
			500	4,035	5,350	9,050
			700	3,090	6,190	11,960
			1,000	1,770	3,400	7,055
Emergency Stop Torque T_{2NOT}	Nm	3	100~1,000	2 times T_{2N}		
Max. Acceleration Torque T_{2B}	Nm	3	100~1,000	1.5 times T_{2N}		
No Load Running Torque ⁽³⁾	Nm	3	100~1,000	6	13	
Backlash ⁽²⁾	arcmin	3	100~1,000	≤ 4	≤ 4	
Torsional Rigidity	Nm/arcmin	3	100~1,000	1,275	5,100	
Nominal Input Speed n_{1N}	rpm	3	100~1,000	2,100	2,000	
Max. Input Speed n_{1B}	rpm	3	100~1,000	4,000	3,000	
Max. Axial Load F_{2a} ⁽⁴⁾	N	3	100~1,000	39,200	143,700	
Max. Tilting Moment M_{2K} ⁽⁴⁾	Nm	3	100~1,000	9,230	63,300	
Operating Temp	°C	3	100~1,000	-10° C ~ 90° C		
Degree of Gearbox Protection		3	100~1,000	IP65		
Lubrication		3	100~1,000	Synthetic lubrication grease		
Mounting Position		3	100~1,000	All directions		
Running Noise ⁽³⁾	dB(A)	3	100~1,000	≤ 72	≤ 74	
Efficiency η	%	3	100~1,000	$\geq 92\%$		

(1) Ratio ($i = N_{in} / N_{out}$).

(2) Backlash is measured at 2% of Nominal Output Torque T_{2N} .

(3) The dB values are measured by gearbox with ratio 1,000 (3-stage), no loading at 3,000 RPM or at the respective Nominal Input Speed by bigger model size.

By lower ratio and/or higher RPM, the noise level could be 3 to 5 dB higher.

(4) Applied to the output flange center at 100 rpm.

(5) Continuous operation is not recommended.

Inertia - MDKA (3 Stage) Gearbox

Model No.	MDKA285	MDKA355	MDKA450
Input Shaft (C3) $\varnothing^{(A)}$			
32	10.18	10.18	-
35	15.21	15.21	15.68
38	20.7	20.7	21.69
42	22.83	22.83	23.59
48	58.45	58.45	59.3
55	-	-	86.95

(A) \varnothing = Input shaft diameter.

Dimension - MDKA (3 Stage) Gearbox (Ratio $i = 100 \sim 1,000$)

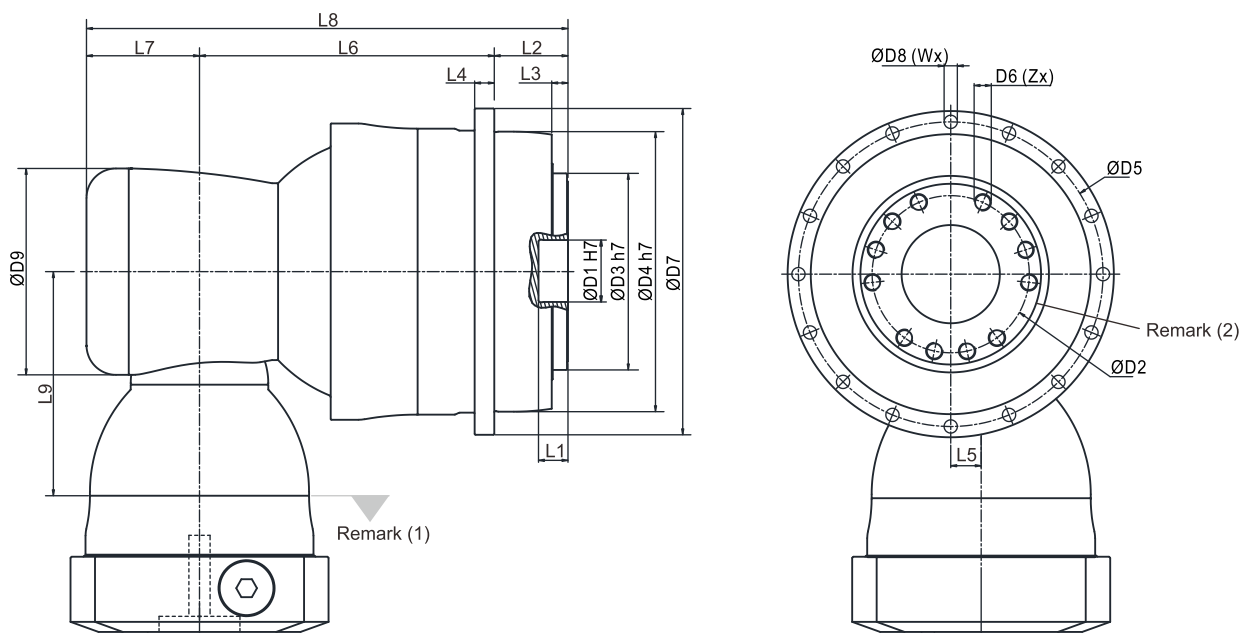

Dimension		MDKA285	MDKA355	MDKA450
D1	H7	100	120	155
D2		160	200	250
D3	h7	200	250	315
D4	h7	285	355	450
D5		310	385	490
D6 x Pitch x Deep		M20x2.5Px31	M24x3Px32	M30x3.5Px40
D7		332	415	530
D8		13.5	17.5	22
D9		210	210	255
L1		16	35	24
L2		75	80	85
L3		16.5	20	20
L4		20	45	60
L5		31	31	36
L6		300	332	447.5
L7		115	115	131
L8		490	527	663.5
L9		228	228	265.5
X in Degree		24	22.5	30
Y in Degree		24	22.5	30
Z		12	16	12
U in Degree		22.5	30	30
V in Degree		22.5	30	30
W		16	12	12

(1) Dimensions are related to motor interface. Please contact APEX for details.

(2) Refer to the MD series (Page 05) for flange interface.

Performance - MDKB (3 Stage) Gearbox

Model No.	Stage	Ratio ⁽¹⁾	MDKB090	MDKB110	MDKB140	MDKB200	MDKB255	MDKB285	MDKB355	
Nominal Output Torque T_{2N} By n_{1N}	Nm	3	64	165	310	690	1,425	1,680	3,280	-
			84	165	300	670	1,380	1,680	3,280	-
			100	165	290	655	1,355	2,085	3,830	6,745
			125	190	330	730	1,355	2,095	3,850	6,785
			140	170	285	630	1,310	2,100	3,860	6,805
			175	190	325	705	1,370	2,115	3,885	6,845
			200	175	290	605	1,265	2,100	3,900	6,865
			250	195	335	680	1,380	2,135	3,920	6,905
			280	180	300	610	1,230	1,560	3,000	-
			350	200	345	705	1,395	1,950	3,750	6,965
			400	160	330	670	1,330	1,440	2,400	-
			500	200	380	760	1,405	1,800	3,000	5,050
			700	135	325	670	1,240	1,875	3,005	6,060
			1,000	55	160	380	660	1,065	1,725	3,325
Emergency Stop Torque T_{2NOT}	Nm	3	64~1,000	2 times T_{2N}						
Max. Acceleration Torque T_{2B}	Nm	3	64~1,000	1.5 times T_{2N}						
No Load Running Torque ⁽³⁾	Nm	3	64~1,000	0.2	0.2	0.3	0.4	1	1.2	1.5
Backlash ⁽²⁾	arcmin	3	64~1,000	≤ 4	≤ 4	≤ 4	≤ 4	≤ 4	≤ 4	≤ 4
Torsional Rigidity	Nm/arcmin	3	64~1,000	27	56	112	389	642	1,275	2,500
Nominal Input Speed n_{1N}	rpm	3	64~1,000	5,500	4,600	4,600	4,000	3,700	3,400	3,100
Max. Input Speed n_{1B}	rpm	3	64~1,000	7,000	7,000	7,000	6,000	5,500	5,000	4,500
Max. Axial Load F_{2a} ⁽⁴⁾	N	3	64~1,000	2,220	4,070	8,530	17,000	26,900	39,200	101,500
Max. Tilting Moment M_{2K} ⁽⁴⁾	Nm	3	64~1,000	280	480	1,310	3,530	5,920	9,230	29,100
Operating Temp	°C	3	64~1,000	-10° C ~ 90° C						
Degree of Gearbox Protection		3	64~1,000	IP65						
Lubrication		3	64~1,000	Synthetic lubrication grease						
Mounting Position		3	64~1,000	All directions						
Running Noise ⁽³⁾	dB(A)	3	64~1,000	≤ 66	≤ 68	≤ 68	≤ 70	≤ 70	≤ 72	≤ 74
Efficiency η	%	3	64~1,000	≥ 92%						

(1) Ratio ($i = N_{in} / N_{out}$).

(2) Backlash is measured at 2% of Nominal Output Torque T_{2N} .

(3) The dB values are measured by gearbox with ratio 1,000 (3-stage), no loading at 3,000 RPM or at the respective Nominal Input Speed by bigger model size.

By lower ratio and/or higher RPM, the noise level could be 3 to 5 dB higher.

(4) Applied to the output flange center at 100 rpm.

(5) Continuous operation is not recommended.

Inertia - MDKB (3 Stage) Gearbox

Model No.	MDKB090	MDKB110	MDKB140	MDKB200	MDKB255	MDKB285	MDKB355
8	0.17	-	-	-	-	-	-
11	0.17	0.52	-	-	-	-	-
14	0.21	0.53	1.83	-	-	-	-
19	-	0.68	1.83	5.6	-	-	-
24	-	-	5.04	5.63	5.63	-	-
28	-	-	-	7.18	7.18	-	-
32	-	-	-	10.1	10.1	12.63	-
35	-	-	-	15.54	15.54	17.75	17.35
38	-	-	-	21.32	21.32	23.26	23.61
42	-	-	-	-	23.2	25.4	25.5
48	-	-	-	-	56.07	61.02	61.22

(A) \varnothing = Input shaft diameter.

Dimension - MDKB (3 Stage) Gearbox (Ratio $i = 64 \sim 1,000$)

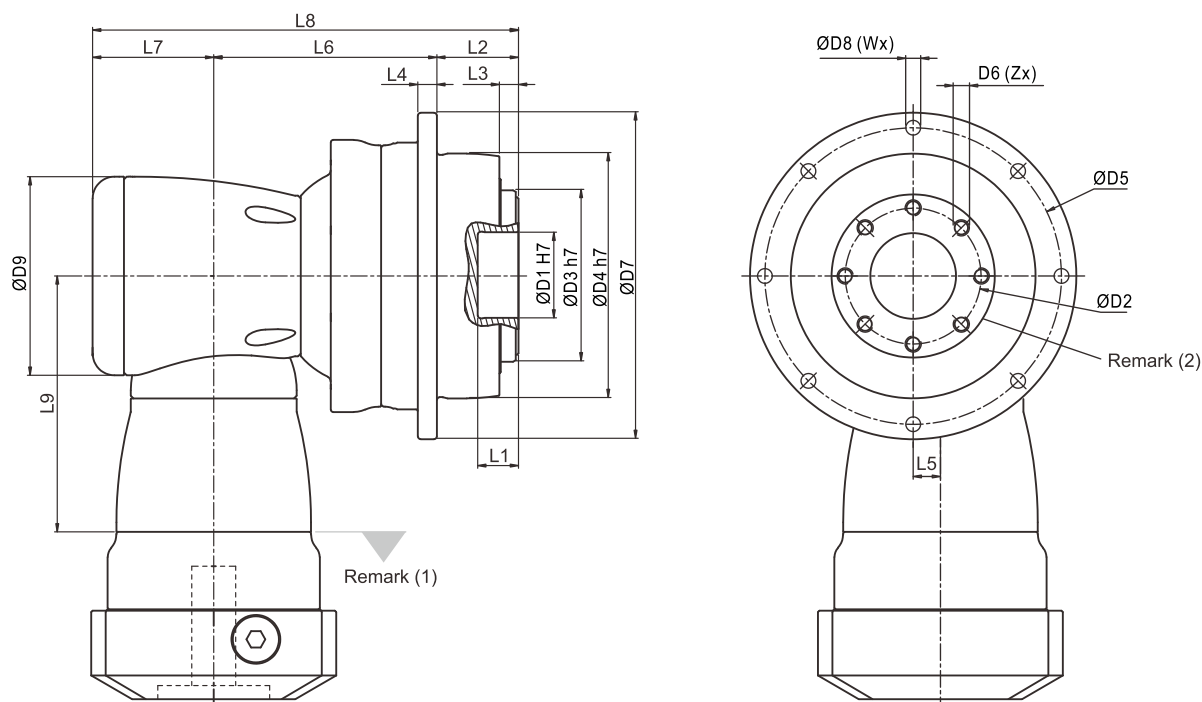

Dimension	MDKB090	MDKB110	MDKB140	MDKB200	MDKB255	MDKB285	MDKB355
D1 H7	31.5	40	50	80	100	100	120
D2	50	63	80	125	140	160	200
D3 h7	63	80	100	160	180	200	250
D4 h7	90	110	140	200	255	285	355
D5	109	135	168	233	280	310	385
D6 x Pitch x Deep	M6x1Px10	M6x1Px11	M8x1.25Px15	M10x1.5Px20	M16x2Px25	M20x2.5Px31	M24x3Px32
D7	120	147	180	249.5	302	332	415
D8	5.5	5.5	6.6	9	13.5	13.5	17.5
D9	94	116	163	210	210	255	300
L1	15	15	15	16	16	16	35
L2	30	29	38	50	66	75	80
L3	7	7	7.5	8.5	13.5	16.5	20
L4	7	8	10	12	18	20	45
L5	13	17	25	31	31	36	43
L6	90.5	114	147.5	175	191.5	249.5	290
L7	53	68.3	89	115	115	131	165
L8	173.5	211.3	274.5	340	372.5	455.5	535
L9	114.5	129	173.5	228	228	265.5	294.5
X in Degree	45	22.5	30	30	24	24	22.5
Y in Degree	45	22.5	30	30	24	24	22.5
Z	8	12	12	12	12	12	16
U in Degree	45	45	30	30	22.5	22.5	30
V in Degree	45	45	30	30	22.5	22.5	30
W	8	8	12	12	16	16	12

(1) Dimensions are related to motor interface. Please contact APEX for details.

(2) Refer to the MD series (Page 05) for flange interface.

Performance - MDK (4 Stage) Gearbox

Model No.		Stage	Ratio ⁽¹⁾	MDK285	MDK355	MDK450
Nominal Output Torque T_{2N} By n_{1N}	Nm	4	1,225	4,070	7,145	13,490
			1,400	4,085	7,170	13,535
			1,750	4,100	7,200	13,585
			2,000	4,120	7,200	12,000
			2,800	3,185	6,320	12,145
			3,500	4,180	7,330	12,650
			5,000	4,285	5,350	9,050
			7,000	3,445	6,780	12,670
			10,000	2,240	4,425	9,370
Emergency Stop Torque T_{2NOT}	Nm	4	1,225~10,000	2 times T_{2N}		
Max. Acceleration Torque T_{2B}	Nm	4	1,225~10,000	1.5 times T_{2N}		
No Load Running Torque ⁽³⁾	Nm	4	1,225~10,000	0.4	0.4	I
Backlash ⁽²⁾	arcmin	4	1,225~10,000	≤ 4	≤ 4	≤ 4
Torsional Rigidity	Nm/arcmin	4	1,225~10,000	1,275	2,500	5,100
Nominal Input Speed n_{1N}	rpm	4	1,225~10,000	3,700	3,700	3,400
Max. Input Speed n_{1B}	rpm	4	1,225~10,000	5,500	5,500	5,000
Max. Axial Load F_{2a} ⁽⁴⁾	N	4	1,225~10,000	39,200	101,500	143,700
Max. Tilting Moment M_{2K} ⁽⁴⁾	Nm	4	1,225~10,000	9,230	29,100	63,300
Operating Temp	°C	4	1,225~10,000	-10° C ~ 90° C		
Degree of Gearbox Protection		4	1,225~10,000	IP65		
Lubrication		4	1,225~10,000	Synthetic lubrication grease		
Mounting Position		4	1,225~10,000	All directions		
Running Noise ⁽³⁾	dB(A)	4	1,225~10,000	≤ 72	≤ 74	≤ 76
Efficiency η	%	4	1,225~10,000	$\geq 90\%$		

(1) Ratio ($i = N_{in} / N_{out}$).

(2) Backlash is measured at 2% of Nominal Output Torque T_{2N} .

(3) The dB values are measured by gearbox with ratio 10,000 (4-stage), no loading at 3,000 RPM or at the respective Nominal Input Speed by bigger model size.

By lower ratio and/or higher RPM, the noise level could be 3 to 5 dB higher.

(4) Applied to the output flange center at 100 rpm.

(5) Continuous operation is not recommended.

Inertia - MDK (4 Stage) Gearbox

Model No.		MDK285	MDK355	MDK450
Input Shaft (C3) $\varnothing^{(A)}$				
24	kg.cm ²	5.63	5.63	-
28		7.18	7.18	-
32		10.1	10.1	12.63
35		15.54	15.54	17.75
38		21.32	21.32	23.26

(A) \varnothing = Input shaft diameter.

Dimension - MDK (4 Stage) Gearbox (Ratio $i = 1,225 \sim 10,000$)

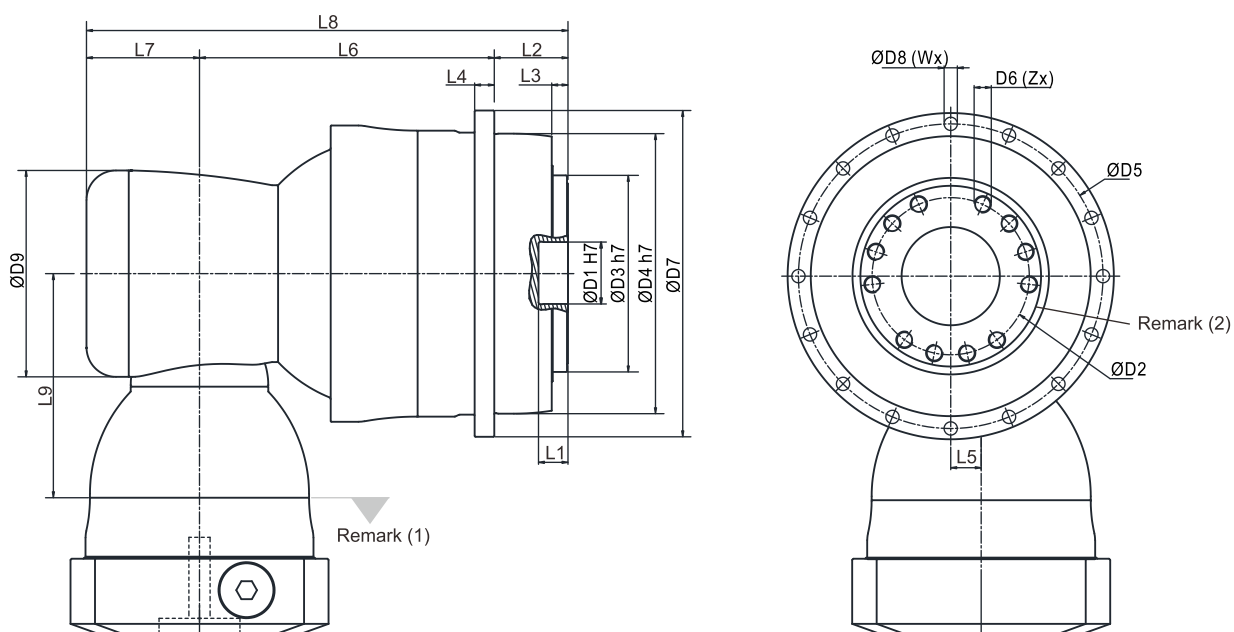

Dimension		MDK285	MDK355	MDK450
D1	H7	100	120	155
D2		160	200	250
D3	h7	200	250	315
D4	h7	285	355	450
D5		310	385	490
D6 x Pitch x Deep		M20x2.5Px31	M24x3Px32	M30x3.5Px40
D7		332	415	530
D8		13.5	17.5	22
D9		210	210	255
L1		16	35	24
L2		75	80	85
L3		16.5	20	20
L4		20	45	60
L5		31	31	36
L6		300	332	447.5
L7		115	115	131
L8		490	527	663.5
L9		228	228	265.5
X in Degree		24	22.5	30
Y in Degree		24	22.5	30
Z		12	16	12
U in Degree		22.5	30	30
V in Degree		22.5	30	30
W		16	12	12

(1) Dimensions are related to motor interface. Please contact APEX for details.

(2) Refer to the MD series (Page 05) for flange interface.

Performance - MDKC Gearbox

Model No.	Stage	Ratio ⁽¹⁾	MDKC064	MDKC090	MDKC110	MDKC140	MDKC200	MDKC255	MDKC285	MDKC355	MDKC450	
Nominal Output Torque T_{2N} By n_{IN}	2	4	100	205	380	775	1,440	2,240	4,160	-	-	
		5	85	185	330	670	1,250	1,930	3,610	-	-	
		7	60	135	260	525	1,000	1,565	2,535	-	-	
		8	96	205	395	800	1,320	2,300	4,260	-	-	
		10	90	190	340	690	1,290	2,000	3,700	-	-	
	3	21	-	195	345	700	1,310	2,045	3,750	6,590	12,630	
		31	-	135	275	565	1,070	1,665	2,660	5,400	10,800	
		46	-	57	160	340	660	1,000	1,710	3,375	6,945	
		61	-	135	285	590	1,115	1,720	2,750	5,580	11,110	
		91	-	57	160	350	660	985	1,600	3,375	6,430	
Emergency Stop Torque T_{2NOT}	Nm	2,3	4~91	2 times T_{2N}								
Max. Acceleration Torque T_{2B}	Nm	2,3	4~91	1.5 times T_{2N}								
No Load Running Torque ⁽³⁾	Nm	2	4~10	2	2.5	5.8	12	25	48	95	-	
		3	21~91	1	1.5	2.5	4	9	18.5	35	75	148
Backlash ⁽²⁾	arcmin	2	4~10	≤ 4	≤ 4	≤ 4	≤ 4	≤ 4	≤ 4	≤ 4	-	-
		3	21~91	-	≤ 4	≤ 4	≤ 4	≤ 4	≤ 4	≤ 4	≤ 4	≤ 4
Torsional Rigidity	Nm/arcmin	2,3	4~91	12	27	56	112	389	642	1,275	2,500	5,100
Nominal Input Speed n_{IN}	rpm	2	4~10	5,000	3,600	3,000	2,300	1,800	1,500	1,100	-	-
		3	21~91	-	4,600	4,000	3,000	2,300	1,800	1,500	1,500	1,100
Max. Input Speed n_{IB}	rpm	2	4~10	7,000	6,000	5,500	4,500	3,500	3,000	2,200	-	-
		3	21~91	-	7,000	6,500	5,500	4,500	3,500	3,000	3,000	2,200
Max. Axial Load F_{2a} ⁽⁴⁾	N	2,3	4~91	1,690	2,220	4,070	8,530	17,000	26,900	39,200	101,500	143,700
Max. Tilting Moment M_{2K} ⁽⁴⁾	Nm	2,3	4~91	120	280	480	1,310	3,530	5,920	9,230	29,100	63,300
Operating Temp	°C	2,3	4~91	-10° C ~ 90° C								
Degree of Gearbox Protection		2,3	4~91	IP65								
Lubrication		2,3	4~91	Synthetic lubrication grease								
Mounting Position		2,3	4~91	All directions								
Running Noise ⁽³⁾	dB(A)	2	4~10	≤ 68	≤ 68	≤ 68	≤ 70	≤ 70	≤ 72	≤ 74	-	-
		3	21~91	-	≤ 68	≤ 68	≤ 70	≤ 70	≤ 72	≤ 74	≤ 74	≤ 76
Efficiency η	%	2	4~10	≥ 95%								
		3	21~91	≥ 93%								

(1) Ratio ($i = N_{in} / N_{out}$).

(2) Backlash is measured at 2% of Nominal Output Torque T_{2N} .

(3) The dB values are measured by gearbox with ratio 10 (2-stage) or ratio 91 (3-stage), no loading at 3,000 RPM or at the respective Nominal Input Speed by bigger model size.

By lower ratio and/or higher RPM, the noise level could be 3 to 5 dB higher.

(4) Applied to the output flange center at 100 rpm.

(5) Continuous operation is not recommended.

Inertia MDKC Gearbox (Ratio $i=4\sim 10 / 21\sim 91$)

Model No.	MDKC064	MDKC090	MDKC110	MDKC140	MDKC200	MDKC255	MDKC285	MDKC355	MDKC450						
$\emptyset^{(A)}$ (C3)	2-st.	2-st.	3-st.	2-st.	3-st.	2-st.	3-st.	2-st.	3-st.	2-st.	3-st.	2-st.	3-st.	3-st.	3-st.
8	0.1	-	0.1	-	-	-	-	-	-	-	-	-	-	-	-
11	0.17	0.52	0.17	-	-	-	-	-	-	-	-	-	-	-	-
14	0.21	0.52	0.21	-	0.52	-	-	-	-	-	-	-	-	-	-
19	0.62	1.69	0.62	1.71	1.69	-	1.71	-	-	-	-	-	-	-	-
24	-	4.89	-	5.05	4.89	6.92	5.05	-	6.92	-	-	-	-	-	-
28	-	-	-	6.55	-	6.98	6.55	-	6.98	-	-	-	-	-	-
32	-	-	-	9.47	-	10.18	9.47	10.18	10.18	-	10.18	-	-	-	-
35	-	-	-	14.91	-	15.21	14.91	15.21	15.21	15.68	15.21	23.46	15.68	-	-
38	-	-	-	20.69	-	20.7	20.69	20.7	20.7	21.69	20.7	23.46	21.69	21.69	-
42	-	-	-	-	-	22.83	-	22.83	22.83	23.59	22.83	25.28	23.59	23.59	25.28
48	-	-	-	-	-	58.45	-	58.45	58.45	59.3	58.45	61.61	59.3	59.3	61.61
55	-	-	-	-	-	-	-	-	-	86.95	-	89.67	-	86.95	89.67
60	-	-	-	-	-	-	-	-	-	-	-	112.49	-	-	112.49

(A) \emptyset = Input shaft diameter.

Dimension - MDKC Gearbox (Ratio $i = 4 \sim 10 / 21 \sim 91$)

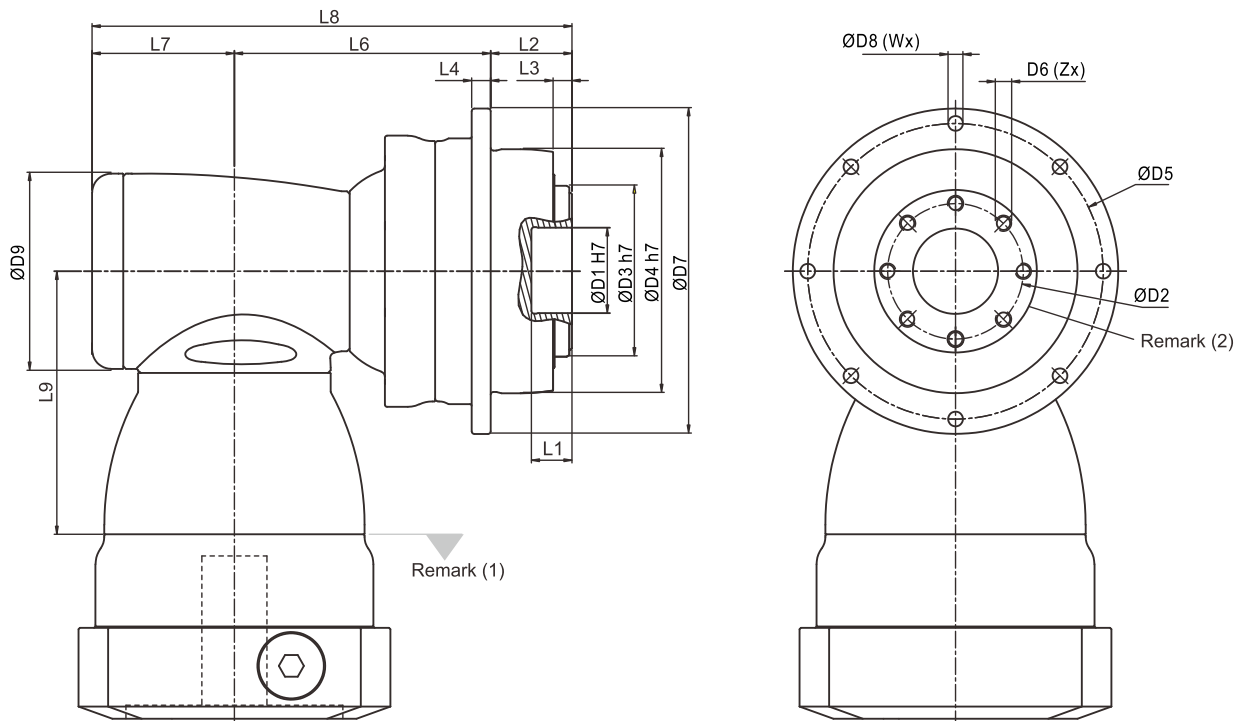

Dimension	MDKC064	MDKC090		MDKC110		MDKC140		MDKC200		MDKC255		MDKC285		MDKC355	MDKC450
	2-st.	2-st.	3-st.	2-st.	3-st.	2-st.	3-st.	2-st.	3-st.	2-st.	3-st.	2-st.	3-st.	3-st.	3-st.
D1 H7	20	31.5		40		50		80		100		100		120	155
D2	31.5	50		63		80		125		140		160		200	250
D3 h7	40	63		80		100		160		180		200		250	315
D4 h7	64	90		110		140		200		255		285		355	450
D5	79	109		135		168		233		280		310		385	490
D6 x Pitch x Deep	M5x0.8Px8	M6x1Px10		M6x1Px11		M8x1.25Px15		M10x1.5Px20		M16x2Px25		M20x2.5Px31		M24x3Px32	M30x3.5Px40
D7	88	120		147		180		249.5		302		332		415	530
D8	4.5	5.5		5.5		6.6		9		13.5		13.5		17.5	22
D9	64	92	64	116	92	156	116	156	156	195	156	240	195	195	240
L1	8	15		15		15		16		16		16		35	24
L2	19.5	30		29		38		50		66		75		80	85
L3	4	7		7		7.5		8.5		13.5		16.5		20	20
L4	5	7		8		10		12		18		20		45	60
L6	92	100.5	121.5	124.5	142	175.5	174.5	185	244.5	199	264.5	265.5	307.5	339.5	463.5
L7	46.5	61.5	46.5	76	61.5	97.5	76	97.5	97.5	105.5	97.5	141	105.5	105.5	141
L8	158	192	198	229.5	232.5	311	288.5	332.5	392	370.5	428	481.5	488	525	689.5
L9	81.5	113.5	81.5	147.5	113.5	196.5	147.5	196.5	196.5	229	196.5	260	229	229	260
X in Degree	45	45		22.5		30		30		24		24		22.5	30
Y in Degree	45	45		22.5		30		30		24		24		22.5	30
Z	8	8		12		12		12		12		12		16	12
U in Degree	45	45		45		30		30		22.5		22.5		30	30
V in Degree	45	45		45		30		30		22.5		22.5		30	30
W	8	8		8		12		12		16		16		12	12

(1) Dimensions are related to motor interface. Please contact APEX for details.

(2) Refer to the MD series (Page 05) for flange interface.

Selection of the optimum gearbox

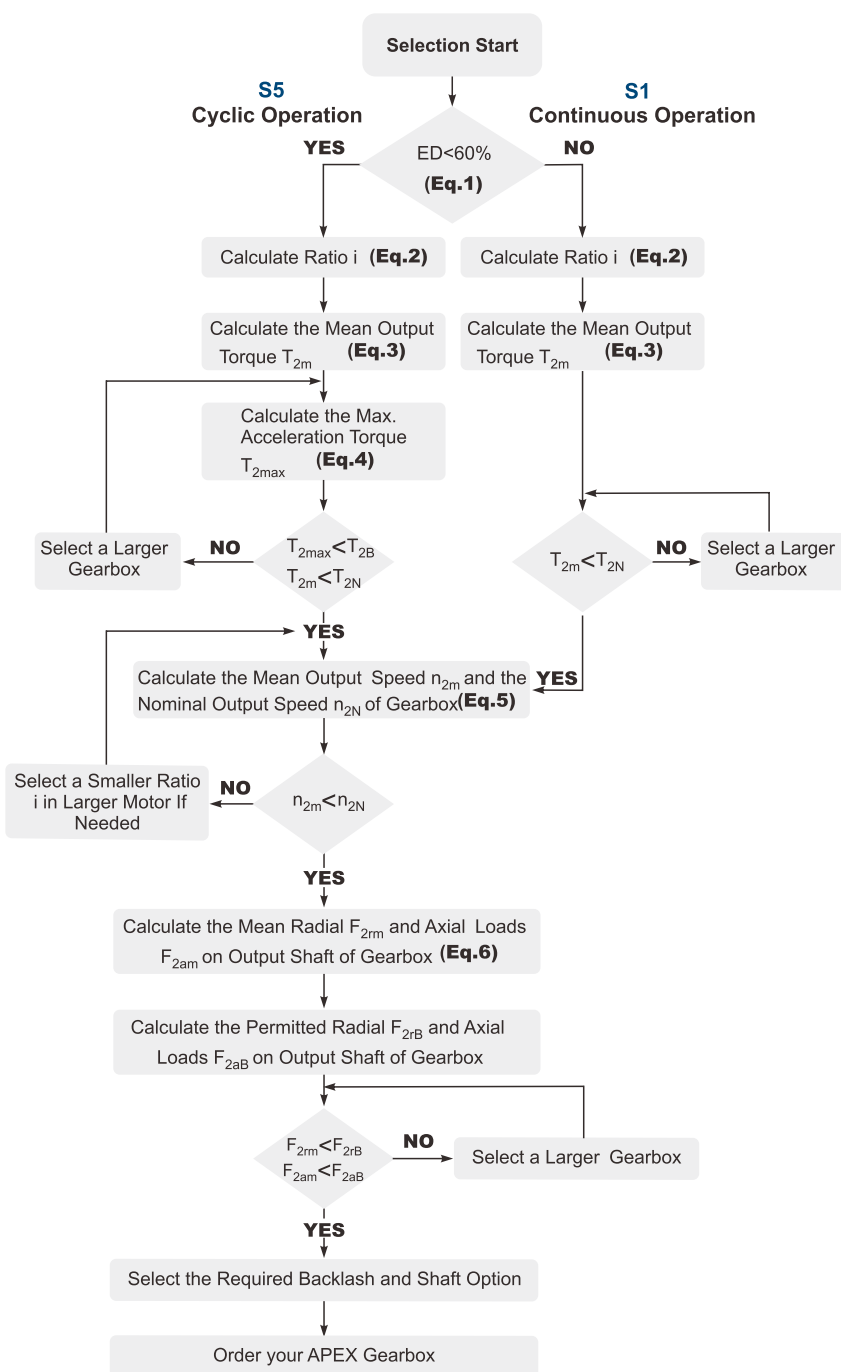

Recommended (for S5 Cycle Operation)

The general design is given for

$$\frac{J_L}{i^2} \leq 4 \times J_m$$

The optimal design is given for

$$\frac{J_L}{i^2} \cong J_m$$

J_L Load Inertia

J_m Motor Inertia

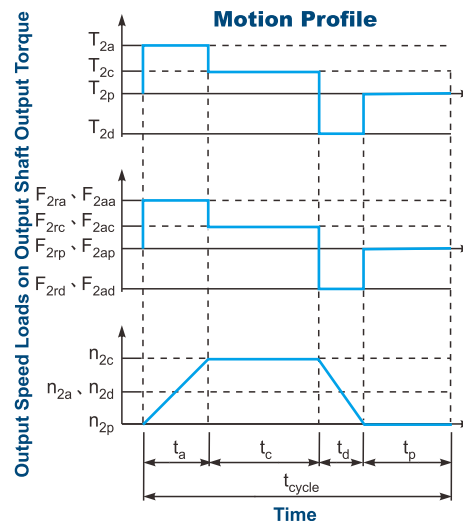

$$1. ED = \frac{t_a + t_c + t_d}{t_{cycle}} \times 100\%$$

Index : a. Acceleration, c. Constant, d. Deceleration, p. Pause

(Eq. 1)

$$2. i \cong \frac{n_m}{n_{work}}$$

n_m Output Speed of the Motor

n_{work} Working Speed

(Eq. 2)

$$3. T_{2m} = \sqrt[3]{\frac{n_{2a} \times t_a \times T_{2a}^3 + n_{2c} \times t_c \times T_{2c}^3 + n_{2d} \times t_d \times T_{2d}^3}{n_{2a} \times t_a + n_{2c} \times t_c + n_{2d} \times t_d}}$$

(Eq. 3)

$$4. T_{2max} = T_{mB} \times i \times K_s \times \eta$$

where K_s is

K_s	No. of Cycles / hr
1.0	0 ~ 1,000
1.1	1,000 ~ 1,500
1.3	1,500 ~ 2,000
1.6	2,000 ~ 3,000
1.8	3,000 ~ 5,000

T_{mB} Max. Output Torque of the Motor

η Efficiency of the Gearbox

(Eq. 4)

$$5. n_{2a} = n_{2d} = \frac{1}{2} \times n_{2c}$$

$$n_{2m} = \frac{n_{2a} \times t_a + n_{2c} \times t_c + n_{2d} \times t_d}{t_a + t_c + t_d}$$

$$n_{2N} = \frac{n_{1N}}{i}$$

(Eq. 5)

$$6. F_{2rm} = \sqrt[3]{\frac{n_{2a} \times t_a \times F_{2ra}^3 + n_{2c} \times t_c \times F_{2rc}^3 + n_{2d} \times t_d \times F_{2rd}^3}{n_{2a} \times t_a + n_{2c} \times t_c + n_{2d} \times t_d}}$$

$$F_{2am} = \sqrt[3]{\frac{n_{2a} \times t_a \times F_{2aa}^3 + n_{2c} \times t_c \times F_{2ac}^3 + n_{2d} \times t_d \times F_{2ad}^3}{n_{2a} \times t_a + n_{2c} \times t_c + n_{2d} \times t_d}}$$

(Eq. 6)

Glossary

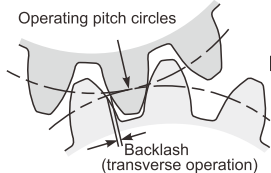
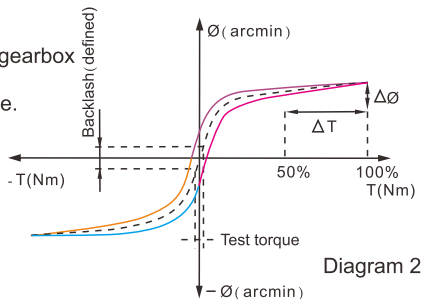
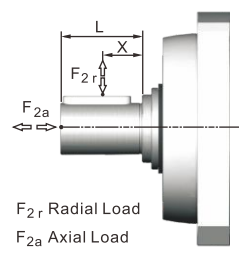
Emergency Stop Torque T_{2NOT}	Nm	The Emergency Stop Torque is the maximum permitted torque at the output of gearbox. This may happen only occasionally and may not exceed 1,000 times during the whole service life.
Max. Acceleration Torque T_{2B}	Nm	Under the Cyclic Operation (S5), the Max. Acceleration Torque is the maximum torque which can be transmitted only briefly to the output of gearbox up to 1,000 cycles/hr.
No Load Running Torque	Nm	The No Load Running Torque is the min. torque to overcome the internal friction of a gearbox without loading*.
Nominal Input Speed n_{1N}	rpm	The Nominal Input Speed is the permitted input speed of gearbox by the Continuous Operation (S1) while the housing temperature does not exceed 90°C. This value is measured at environment temperature 25°C.
Max. Input Speed n_{1B}	rpm	The Max. Input Speed is the max. permitted input speed of gearbox by the Cyclic operation (S5). This value is measured at environment temperature 25°C and serves as the absolute limit of the gearbox.
Backlash	arcmin	<p>The Backlash is the maximum angular measurement between two teeth of gears when the transverse operation occurs (refer to Diagram 1). The arcmin is the measurement unit for the backlash. One arcmin equals 1/60 degree, symbolized as 1'.</p> 
Torsional Rigidity	Nm/arcmin	<p>Torsional Rigidity is the quotient ($\Delta T / \Delta \theta$) between the applied torque and resulting torsion angle. This value indicates how much torque is needed on the gearbox to rotate the output shaft for 1 arcmin. The Torsional Rigidity can be determined by Hysteresis Curve.</p> <p>Hysteresis Curve When the input shaft is locked, increase torque at the output slowly up to T_{2B} in both directions and then release the torque gradually. According to the measured torque and torsion angle, a closed curve will be acquired as in the Diagram 2.</p> 
Radial Load And Axial Load	N	<p>The permitted radial and axial loads on output shaft of the gearbox depend on the design of the gearbox supporting bearings.</p> <p>For more information, please refer to APEX website.</p> 
Efficiency η	%	The transmission efficiency of the gears inside a gearbox (without friction).
Operating Temperature	°C	The Operating Temperature indicates the temperature of gearbox housing.
Degree of Protection		IP code stands for International Protection standard. The IP65 as example: the first IP number stands for protection degree against dust; the second IP number stands for protection against liquid.
Lubrication		APEX uses synthetic lubrication grease. Alternate greases are available, please contact APEX.
Running Noise	dB(A)	The Running Noise is measured depends on gearbox size, the ratio and the speed*. Higher speed usually induces higher noise level, while higher ratio induces lower noise level.
Moment of Inertia J_1	kg.cm ²	The Moment of Inertia J_1 is a measurement of the effort applied to an object to maintain its momentary condition at rest or rotating.
Breakaway Torque	Nm	The Breakaway Torque is the minimum torque to start the rotation from the input side of gearbox. A smaller size or a higher ratio gearbox requests less Breakaway Torque.
Back Driving Torque	Nm	The Back Driving Torque is the minimum torque to start the rotation from the output side of gearbox. A larger size or a higher ratio gearbox requires greater Back Driving Torque.

* This value is measured at environment temperature 25°C and the input speed 3,000 rpm. If the Nominal Input Speed n_{1N} of gearbox is lower than 3,000 rpm, this value is measured by that specific Nominal Input Speed.

Liability Disclaimer:

APEX DYNAMICS, INC. endeavors to ensure the accuracy and reliability of the data in catalog.

APEX accepts no liability, whether in any form, for any loss or damage arising from any inaccuracy or omissions of this catalog.

Note



**APEX TAIWAN NORTH
ANDTEK AUTOMATION CO.,LTD**
TEL +886-02-82262655
13F-5, NO.2, Jian 8th Rd., Jhonghe Dist., New
Taipei City 235, TAIWAN
sales@andtek.com.tw
www.apexdyan.com



**APEX TAIWAN CENTRAL
ANDTEK AUTOMATION CO.,LTD**
TEL +886-04-23594286
9F-6, NO.925, Sec.4, Taiwan Blvd., Xitun Dist.
Taichung City 407, TAIWAN
sales@andtek.com.tw
www.apexdyan.com



**APEX TAIWAN SOUTH
MEN JENN ELECTRIC CO., LTD.**
TEL +886-06-2337332*6
NO.774, Zhonghua Rd., Yongkang Dist., Tainan
City 710, TAIWAN
menjenn@ms24.hinet.net
www.apexdyan.com



APEX TAIWAN INC. SHANGHAI
TEL +86-21-69220577
NO.128 ZHUHYING Road QINGPU Industry Area,
Shanghai, CHINA
sales@apexdyna.cn
www.apexdyan.cn



APEX DYNAMICS SHENZHEN, LTD.
TEL +86-755-84516325
NO. 1102A of D area, CFG mansion, Bao Yuan
Road, Bao' an District, Shenzhen, CHINA.
sales@szapexdyna.com
www.szapexdyna.com



APEX DYNAMICS BEIJING, LTD.
TEL +86-10-69570691
NO. 1, Yao Ping Road, Song Zhuang Town, Tongzhou
District, Beijing, CHINA.
bjapexdyna@163.com
www.bjapex.cn



CHONGQING APEX DYNAMICS CO., LTD.
TEL +86-23-67686860
406, Building 5, NO. 68, Jinyu Avenue, Beibu New
Area, Chongqing, CHINA
sales@cqapexdyna.com
www.apexdyna.com



APEX (XIAMEN) DYNAMICS TECHNOLOGY CO., LTD.
TEL +86-0592-720-5279
Unit B-3, 1F., NO. 129, Jingquan Road, Jimei District,
Xiamen, Fujian, CHINA
sales@xmapexdyan.com
www.xmapexdyna.com



APEX DYNAMICS USA, INC.
TEL +1-631-2449040
885 Marconi Avenue Ronkonkoma, NY 11779
U.S.A.
sales@apexdynamicsusa.com
www.apexdynamicsusa.com



APEX DYNAMICS KOREA INC
TEL +82-31-8179992
7-5, Aenigol-gil, Ilsandong-gu, Goyang-si, Gyeonggi-do,
Republic of Korea 10301
sales@apexdynakorea.co.kr
www.apexdynakorea.co.kr



APEX DYNAMICS JAPAN
TEL +88-092-4511202
1-3-46, Hamnichibasi, Hakata-ku, Fukuoka,
812-0897, JAPAN
sales@apexdyna.jp
www.apexdyna.jp



APEX DYNAMICS SINGAPORE PTE LTD
TEL +65-62-626228
3 South Buona Vista Road, #05-15 & #06-15.
SINGAPORE 118136
sales@apexdyna.com.sg
www.apexdyna.com.sg



APEX DYNAMICS (THAILAND) CO., LTD.
TEL +66-2-326623
87 Soi Ladkrabang 30, Ladkrabang, Ladkrabang,
Bangkok 10520, Thailand
Apexthai2010@gmail.com
www.apexdyna.co.th



APEX DYNAMICS BV
TEL +31-492-509995
Churchillaan 101 5705 BK Helmond, NETHERLANDS
sales@apexdyna.nl
www.apexdyna.be



**APEX DYNAMICS
POLSKA SP. Z O.O.**
TEL +48-12-6304728
Ul. Krakowska 50, 32-083 Balice, Poland
sales@apexdyna.pl
www.apexdyna.pl



APEX DYNAMICS SPAIN, S.L.
TEL +34-93-6562990
Poligono Industrial Moli dels Freres, Calle C nº
12,08620-Sant Vicenç dels Horts, Barcelona, SPAIN
apexdyna@apexdyna.es
www.apexdyna.es



Big Diamond Trading Company LLC
TEL +968-94268885
2nd floor, Regus, Tamimah building, Al
Wattayah, Muscat, Oman
ar.gorji@diamondtradings.com



APEKS DINAMIK REDUKTOR DISLI SAN TIC AS
TEL +90-232-4589960
10053 SOKAK NO: 9 A.O.S.B. CIGLI- IZMIR- TURKEY
sales@apexdyna.com.tr
www.apexdyna.com.tr



APEX DYNAMICS AUSTRALIA PTY LTD.
TEL +613-95-852739
36 Taunton Drive,Cheltenham, Victoria 3192
AUSTRALIA
sales@apexdyna.com.au
www.apexdyna.com.au



APEX DYNAMICS (I) JV
TEL +91-9607927142
Shop No. 02, S. No. 100/5, Pune-Satara Highway,
Ambegaon Khurd, Pune-411046 Maharashtra, India
sales@apexdyna.co.in
www.apexdyna.co.in



APEX DYNAMICS FRANCE SAS
TEL +33-160-135097
11 - Burospace - 91570 - Bièvres, France
info@apexdyna.fr
www.apexdyna.fr



APEX DYNAMICS SWEDEN AB
TEL +46-75-2424444
Fredrikbergsgatan 2 SE-573 92 Tranås, SWEDEN
sales@apexdyna.se
www.apexdyna.se



PT.APEX DYNAMICS INDONESIA
TEL +62 21 2928 3681
Rukan Aralia Blok HY43 no.11, Harapan Indah II,
Bekasi - Jawa Barat, INDONESIA 17214
sales@apexdyna.co.id
www.apexdyna.co.id



APEX DYNAMICS GERMANY GMBH
TEL +49-7171 798069-0
Marie-Curie-Straße 25 D-73529 Schwäbisch Gmünd
werner.langer@apexdynamics.de
www.apexdynamics.de



APEX DYNAMICS CZECH S.R.O.
TEL +420-577-663877
tř. Tomáše Bati 1851 765 02 Otrokovice Česká
REPUBLIKA
info@apexdynaczech.cz
www.apexdynaczech.cz



APEX DYNAMICS РОССИЯ
TEL +7-495-2255452
TEL +7-495-6462422
г.Москва,ул. Южнопортовая, дом 7, строение
"С", 3-й этаж
info@apexdynarussia.ru
www.apexdynarussia.ru



APEX DYNAMICS MIDLANDS LTD
TEL +44-0121-737-1170
Heath House, Cheadle Rd, Uttoxeter,
ST14 7BY, UK
mikeg@apexdynauk.com
www.apexdynauk.com



APEX DYNAMICS SWITZERLAND AG
TEL +41-55-4517020
Obergasse 40, CH-8854 Galgenen, Switzerland
info@apexdyna.ch
www.apexdyna.ch



APEX DYNAMICS MOTION (M) SDN BHDTEL
TEL +60 7237 1055
Block A1-2, #35-03, Mercu 1 Jalan Tanjung Puteri 1,
R & F Tanjung Puteri, Johor Bahru 80300, Johor.
sales@apexdyna.com.sg
www.apexdyna.com.sg



APEX DYNAMICS BRAZIL
TEL +55-47-30298700
Rua Senador Petrónio Portela, 47-Bloco 5, Zona
Industrial Norte-CEP 89218-575-Joinville (SC)
luciano@neoyama.com.br
adriano.tuarte@neoyama.com.br
www.neoyama.com.br



APEX DYNAMICS ITALY SRL
TEL +39 02 36634521
VIA E. DE AMICIS, 2-20091 BRESSO (MI)
info@apexdynamics.it
www.apexdynamics.it



APEX DYNAMICS AUSTRIA GmbH
TEL +43 720788416
Dr. Hans-Lechner-Strasse 6,
5071 Wals-Siezenheim
info@apexdynamics.at
www.apexdynamics.at



UAB "APEKSO DINAMIKA"
TEL +370 52078165
Medaus g. 28A,
Medininuku k., Vilnius r. Sav.
LT-13192
info@apexdyna.lt



APEX DYNAMICS DENMARK
TEL +45 73121260
Grundtvigs Allé 165, 6400
Sønderborg, Denmark
sales@apexdyna.dk
www.apexdyna.dk



APEX DYNAMICS ISRAEL
TEL +972-3-6470471
17 Hamefalsim St., Kiryat Arye,
Petach-Tikva 4951447
Sales@apexdynamics.co.il
www.apexdynamics.co.il



APEX DYNAMICS SLOVAKIA S.R.O.
TEL +421919400476
Trenčianska cesta 887/52, 957 01
Bánovce nad Bebravou, Slovak republic
office@apexdyna.sk
www.apexdyna.sk



APEX DYNAMICS, INC.

No10. Keyuan 3rd RD.Situn District, Taichung City 40763, Taiwan (R.O.C)
Tel:886-4-24650219 | Fax:886-4-24650118
sales@apexdyna.com | <http://www.apexdyna.com>

APEX-2023-09-MD/MDK SERIES-1.0-TWN

Printed in Taiwan

