



Linear Actuator

Technical Information





Linear Motor Stage

Semiconductor / Precision / Automated Transport / Automated Optical Inspection (AOI)

- Planar Servo Motor
- Air Bearing Platform
- X-Y Stage
- Gantry Systems
- Single-Axis Linear Motor Stage



Linear Motor

Machine Tool / Semiconductor / Touch Panel / Laser Manufacturing Machine / Glass Cutting Machine

- Iron Core Linear Motor--LMSA, LMSA-Z, LMFA, LMFC, LMFP Series
- Ironless Linear Motor--LMC Series
- Tubular Motor--LMT Series



Torque Motor & Direct Drive Motor

Machine Tools / Semiconductor / Lithium-ion Battery / Laser Marking / Wafer Dicing

- Torque Motor-- TM-2 / IM-2, TMRW Series
- Display / Automation / Semiconductor / Lithium-ion Battery / Robot / Laser Marking / Automated Optical Inspection (AOI) Industry
- Direct Drive Motor-- DMS, DMY, DMN, DMT Series



Controller / Drive / AC Servo Motor

PCB / Display / Machine Tools / Semiconductor / Automated / Food / Automated Optical Inspection (AOI) Industry

- Controller--HIMC
- Drive--E1, E2, D1, D2T Series
- AC Servo Motor-- E1 Series, FR Series, abi Series



Linear Actuator / Servo Actuator

Medical / Automation / Electric Servo Press / Barrier-free Equipment Industry

- Servo Actuator--LAA Series
- Linear Actuator--LAM, LAS, LAN, LAC Series



Position Measurement System

PCB / Woodworking / Automation / Warehouse Automation Programmable Industry

- High Resolution--PM-A, PM-B, PM-C
- Signal Translator
- High Performance Counter



Semiconductor Subsystem

Semiconductor / LED / Panel

- EFEM (Equipment Front End Module)
- Wafer Robot
- Load Port
- Wafer Aligner



Multi-Axis Robot

Pick-and-Place / Assembly / Array and Packaging / Semiconductor / Electro-Optical Industry / Automotive Industry / Food Industry

- Articulated Robot
- SCARA Robot
- Electric Gripper
- Integrated Electric Gripper



Single-Axis Robot

Precision / Semiconductor / Medical / FPD

- KK, SK
- KS, KA
- KU, KE, KC



Torque Motor Rotary Table

Medical / Automotive Industry / Machine Tools / Machinery Industry

- RAB Series
- RAS Series
- RCV Series
- RCH Series



Ball Screw

Precision Ground / Rolled

- Super S Series
- Super T Series
- Mini Roller
- Ecological & Economical Lubrication Module E2
- Rotating Nut (R1)
- Energy-Saving & Thermal-Controlling (Cool Type)
- Heavy Load Series (RD)
- Ball Spline

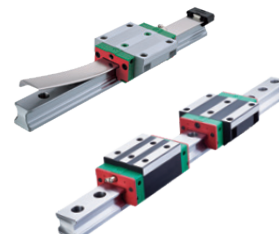

Linear Guideway

Automation / Semiconductor / Medical

- Ball Type--HG, EG, WE, MG, CG
- Quiet Type--QH, QE, QW, QR
- Other--RG, E2, PG, SE, RC

HIWIN® MIKROSYSTEM

Contents

Linear Actuator

1. Introduction	04
1.1 Sizing of a HIWIN Linear Actuator	4
1.2 Installation of a HIWIN Linear Actuator	4
1.3 Regulations to Safely Operate HIWIN Linear Actuators	4
1.4 Features & Applications.....	5
2. HIWIN LAM Series	06
2.1 LAM1-1.LAM1-2.....	6
2.2 LAM2	8
2.3 LAM3	10
3. HIWIN LAS Series	12
3.1 LAS1	12
3.2 LAS2	14
3.3 LAS3	16
3.4 LAS4	18
4. HIWIN LAN Series	20
4.1 LAN1	20
4.2 LAN3A	22
4.3 LAN4	24
4.4 LAN5	26
5. HIWIN LAC Series	28
5.1 LAC1	28
6. HIWIN 1-Axis Controller	30
6.1 LAK2LN.....	30
7. HIWIN 2-Axis Controller	32
7.1 LAK2.....	32
7.2 LAK2BN.....	34
7.3 LAK2D	36
7.4 LAK2J.....	38
8. HIWIN 4-Axis Controller	41
8.1 LAK4D	41
9. HIWIN 6-Axis Controller	43
9.1 LAK6B	43
10. HIWIN Battery-LAKB	46
11. HIWIN Over Current Protection Box-LAKC1-1	47
12. HIWIN Keypad Series	49
13. HIWIN 2-Axis Controller	55
13.1 Standard Cable length of the actuator	55
13.2 HIWIN Options for each Actuator Type	57
13.3 HIWIN Option for each Controller Type	58
13.4 HIWIN Customer Requirements (LA)	59

Linear Actuator

1.Introduction

1-1. Sizing of a HIWIN Linear Actuator

Step 1: Determine the load and speed

Consider the operating environment, compare the specifications of various types of Hiwin Linear Actuators and select the most appropriate model.

Step 2: Stroke and retracted length sizing

Consider the dimensions of the operating area and select the appropriate actuator.

Step 3: Duty cycle

Duty cycles should not exceed 10%. If the duty cycle exceeds 10%, the life of the actuator can be reduced. Users should make sure that no torsion or impact forces are acting upon the actuator.

Step 4: Controller sizing

The controller selection should be made according to the power requirements of the actuator. Other considerations include the number of axes, type of limit switches and the series of keypad.

1-2. Installation of a HIWIN Linear Actuator

- Please ensure that the extension tube is at the "lowest position". The term "lowest position" refers to the position where there is no further movement towards the DC motor while the actuator is powered on.
- The front and end joints of the linear actuator should be mounted onto two fixed positions on the main chassis. Locations of these fixed positions should be chosen according to the stroke length of the linear actuator.
- After the fixed positions have been selected, install the fixtures onto these selected positions of the main chassis. These fixtures are used to fix the front and end joints of the linear actuator.
- Assemble the front and end joints of the linear actuator onto the two fixtures using fixture bolts. Please ensure that the fixture bolts rotate freely when this step is completed. Also, please ensure that the fixture bolts do not become "loose" and fall off during operation.
- The chassis of the linear actuator should be mounted in the horizontal direction if it is going to be operated in this direction and likewise for vertical operation. Damages could occur to the actuator if these instructions are not followed.
- Make sure that:
 - The travel distance of the actuator matches the design requirements.
 - The upper and lower limit switches are functioning.
 - The motor stops when the extension tube reaches the upper and lower limit switches.

* If the actuator does not operate as described above, please repeat steps 2 thru 4 to make sure that the installation is correct.

** All HIWIN linear actuators and control boxes have to be grounded.

1-3. Regulations to Safely Operate HIWIN Linear Actuators

- A no-load operation may damage the actuator, especially if the actuator has external limit switches installed.
- Please make sure that the actuators are not installed where the motor or any mechanical parts can be damaged due to dangerous environments.
- Make sure the DC voltage supplied to the actuator matches the specifications on the actuator. The power supply should supply enough power under maximum load.
- Under extreme load situations, the motor will try to draw more than the rated current. It is the operator's duty to ensure that the power supply does not provide more current than specified on the actuator. Excessive current will cause wiring damage and possible failure of the actuator. Unless otherwise specified, our actuators have a duty cycle rating of 10%. The duty cycle is defined as two minutes of continuous operation, followed by 18 minutes of non-operation. If the duty cycle exceeds 10%, please consider over-current protection measures. Install protection devices such as fuses or an over-current detection between the power supply and the actuator input end. Detection signals are to be used for operation interruption or shut down.
- Thermal protection is included on some Hiwin linear actuator models. This will shut down the motor when over-heated.
- If the actuator was purchased without limit switches, please install appropriate limit switches that comply with the power supply and over-current protection devices that are used.
- The actuator's motors are DC driven. When the motor is not in operation, please short the ends of the power input to provide additional locking power. Make sure the controller power is shut off prior to shorting the motor inputs. The movement of the extension tube can be reversed by changing the polarity of the voltage supplied.
- Make sure the actuator operates within its stroke length if it is not supplied with limit switches or an over load protection device.
- The actuator should operate within the rated load specifications.
- Please make sure the actuator is operating within the IP rating for dust and water.
- For applications requiring high accuracy and tight speed requirements, please inquire about Hiwin's KK-series linear stages.
- Electrical self locking should be implemented if the Hiwin controller is not being used. This will increase the actuator's locking force. Electrical self.
- If client need to adjust the location of external limit, please make mark on original spot (drawing line with pen, sticker gluing etc.) to prevent linear actuator get damaged.
- The specification of the external limit please refer to approved drawing and guidebook.

1-4. Features & Applications

1. Features of a Linear Actuator

- Light weight and compact structure
- Low noise
- User friendly
- High rigidity
- Simple installation
- Competitive price

2 Applications

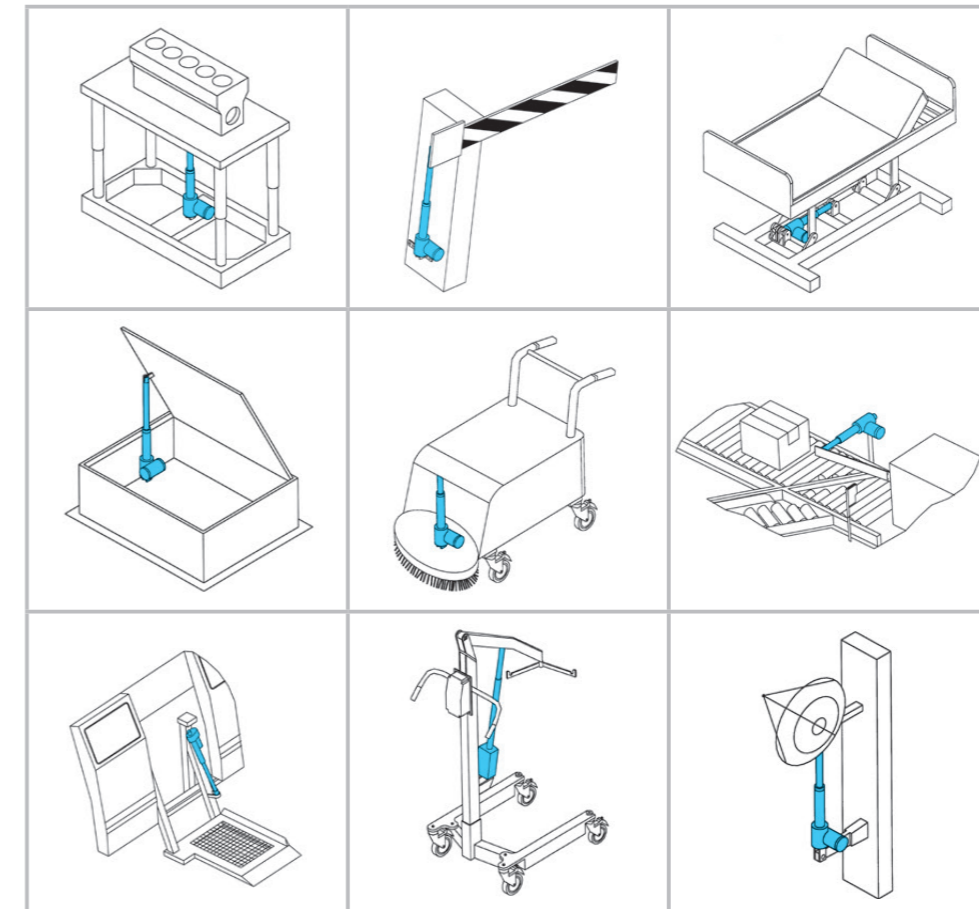

- Automation equipment
- Automatic windows and doors
- Automatic cupboards
- Automatic satellite antennas
- Automatic wheel chairs
- Automatic hospital beds
- Entertainment facilities
- Household appliances
- Automatic drawing tables
- Home care facilities
- Patient lifters
- Massage chairs
- Traffic facilities
- Office automation
- Automatic PC desks
- Hospitals and rehabilitation enters
- Nursing homes

Linear Actuator

2.LAM Series

2-1. HIWIN LAM Series (1)

LAM1-1 / -2

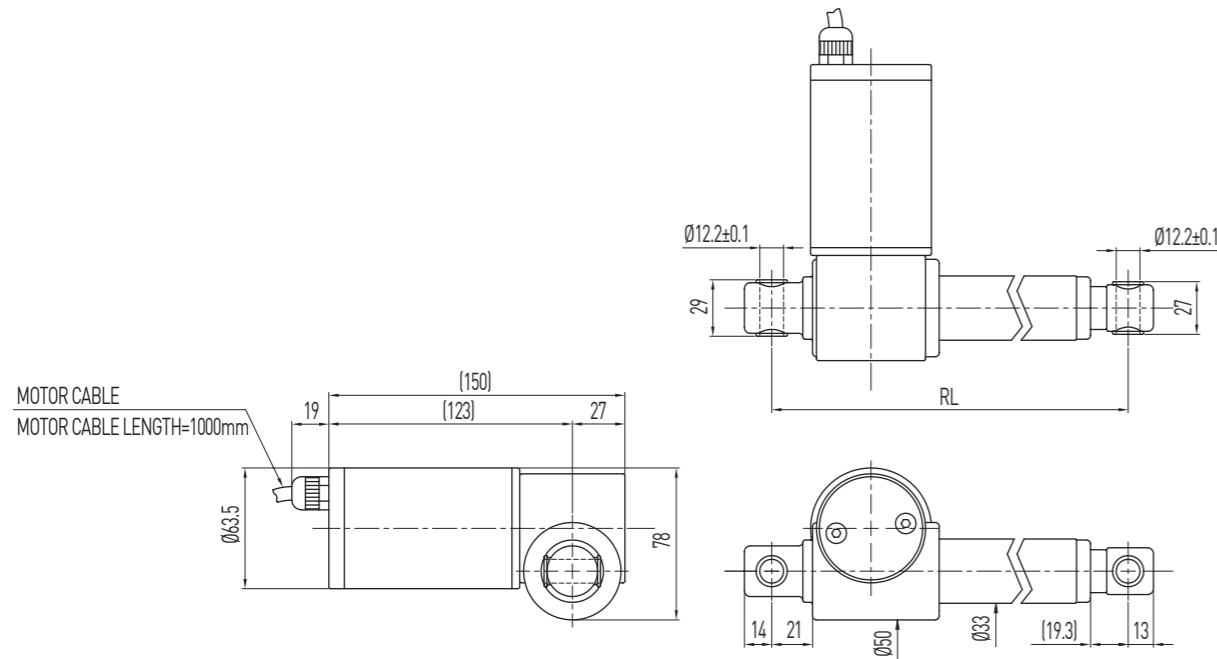

- LAM1-1/-2
RL = S+153
Stroke ≤ 400
RL: Retracted length
S: Stroke length
- LAM1-1A
RL = S+162
Stroke ≤ 400

When LAM1 is equipped with external Reed switch, a heat-shrink tube is installed next to the front limit switch to restrict its location.

Table 2.1 Specifications

Screw type	Ballscrew / ACME
Weight*	2.31kg
Protection	IP54
Compatible controller	LAK2 / LAK2LN / LAK2D / LAK2BN / LAK2J / LAK6B
Working temp.	+5°C-40°C

* Stroke length 100mm

Option:

- (1) IP65
- (2) Gear box housing turned 90°
- (3) UL version only 24VDC motor specifications (Only 24VDC certified by UL)
- (4) Plug: DIN 4PIN plug / Stereo plug

Table 2.2 LAM1 Specifications

Model	Screw type	Thrust max. (N)	Pulling max. (N)	Holding max. (N)	Speed (mm / s) Load = Max . / Load = 0	Standard stroke (mm) : S						Duty cycle %	Current max. (A)		
						100	150	200	250	300	350		400	12VDC	24VDC
LAM1-1	Ballscrew	4000	3000	4000	8 / 11	100	150	200	250	300	350	400	10	12	6
LAM1-2	Ballscrew	2000	2000	1200	16 / 21	100	150	200	250	300	350	400	10	12	6
LAM1-1A	ACME	3000	3000	3000	8 / 11	100	150	200	250	300	350	400	10	12	6

*Min. input power = Voltage x Current max.

LAM1-1/-2/-1A

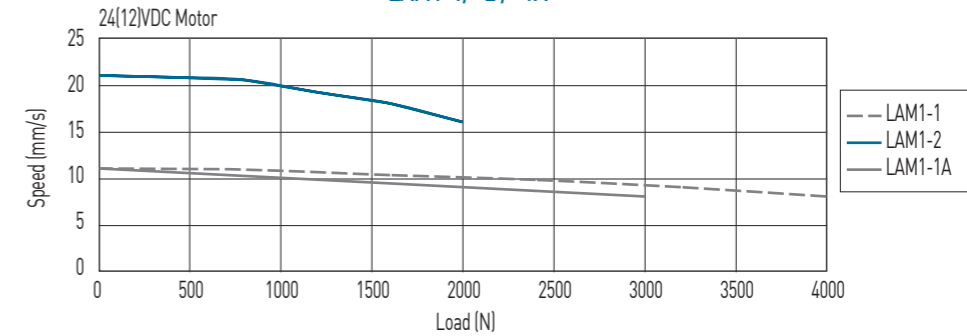

LAM1-1/-2/-1A

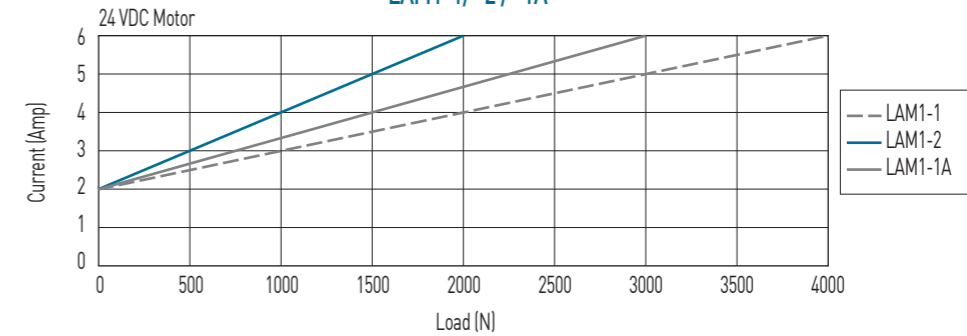

**Note: The test results are obtained by using the 24VDC power supply.

LAM1-1/-2/-1A

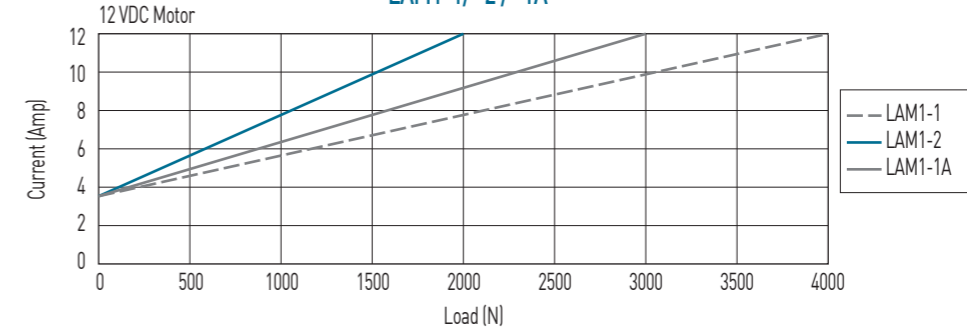

**Note: The test results are obtained by using the 12VDC power supply.

Ordering Information

LAM1 - 1 - 0 - 200 - 24 E				
Model number (Ballscrew: 1,2) (ACME: 1A)	0 : Basic model (without magnet) 2 : Complete with electronic limit switches	Stroke length	Voltage 24:Standard motor 12:12VDC Standard	Special models according to the customer's requirement (Ignore this part of the serial number if not available)

*Remark: The over-current protection is for over load protection, do not use for limit stop. Suggestion: To add external limit switch as limit positions stop.

Linear Actuator

2-2. HIWIN LAM Series (2)

LAM2

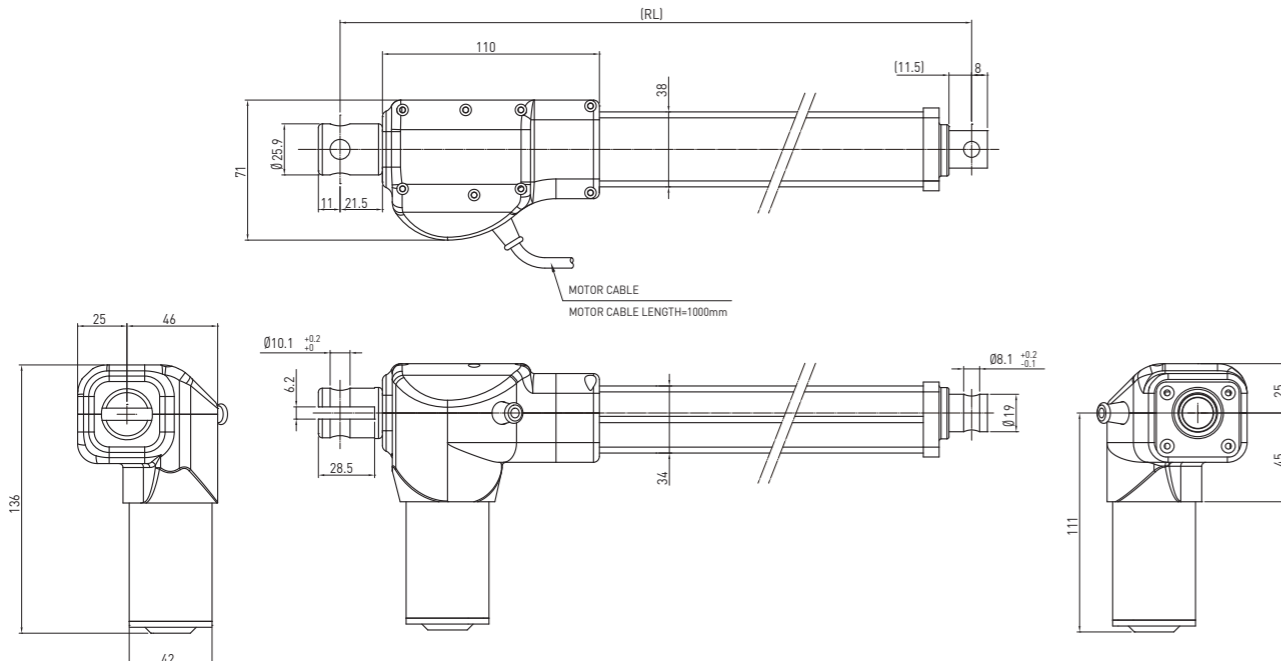

- RL = S+157
Stroke ≤ 300
RL: Retracted length
S: Stroke length

Table 2.3 Specifications

Screw type	ACME
Weight*	1.9kg
Protection	IP54
Compatible controller	Compatible with all controllers (*Notice the type of connector: Audio/DIN 4pin)
Working temp.	+5°C~40°C

* Stroke length 200mm

Option:

- (1) External reed switch (RL=S+207, S ≤ 300)
- (2) MR Sensor (Position feedback)
- (3) Back fixture turned 90°
- (4) IP66
- (5) Plug: DIN 4PIN plug / Stereo plug
- (6) UL Version

Table 2.4 LAM2 Specifications

Model	Thrust max. (N)	Pulling max. (N)	Holding max. (N)	Speed (mm/s) Load = Max. / Load = 0	Standard stroke (mm) : S					Duty cycle %	Current max. (A)		MR Sensor Resolution (mm / pulse)
					100	150	200	250	300		12VDC	24VDC	
LAM2-1	3500	3500	3000	2 / 3.5	100	150	200	250	300	10	8	4	0.1
LAM2-2	2500	2500	2000	3 / 6	100	150	200	250	300	10	8	4	0.16
LAM2-3	1500	1500	1500	6.5 / 12	100	150	200	250	300	10	6	3	0.32

*Min. input power = Voltage x Current max.

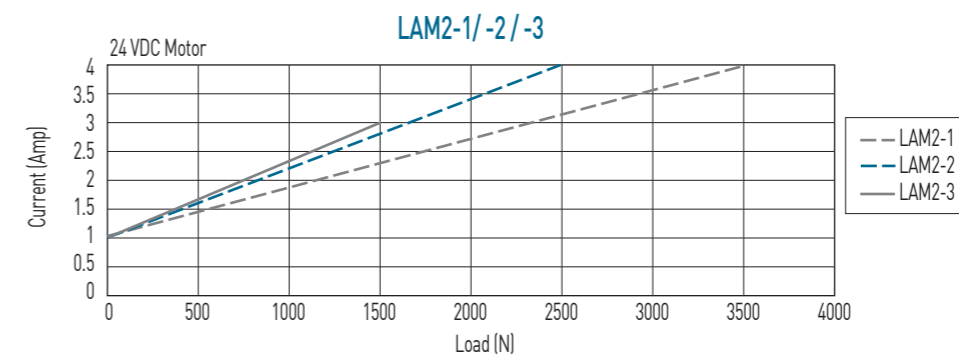
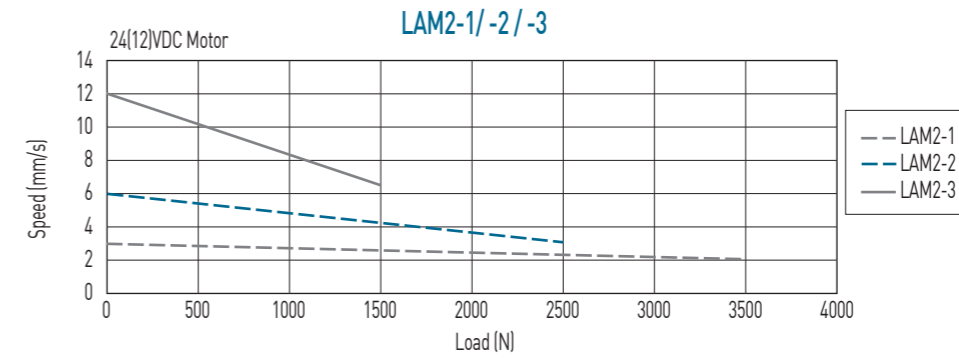

**Note: The test results are obtained by using the 24VDC power supply.

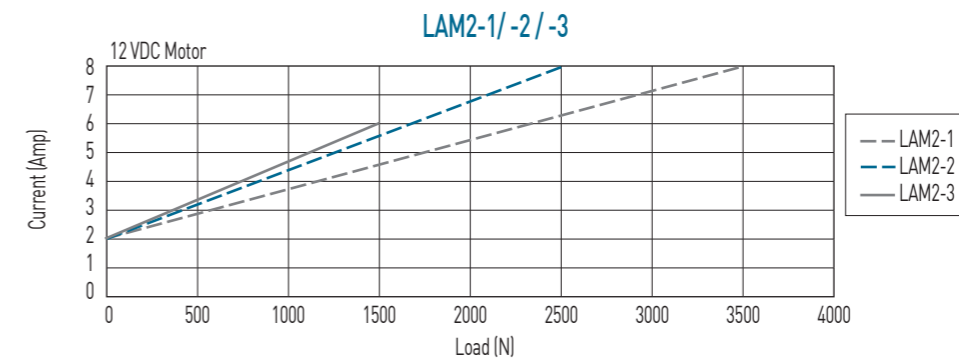

**Note: The test results are obtained by using the 12VDC power supply.

Ordering Information

Model number	LAM2 - 1 - 1 - 200 - 24 G E
1 : Basic model complete with internallimit switches	Stroke length
	Voltage
	24: Standard motor
	12: 12VDC Standard
	Color
	B : Black
	G : Gray
	Special models according to the customer's requirement (Ignore this part of the serial number if not available)

Linear Actuator

2-3 HIWIN LAM Series (3)

LAM3

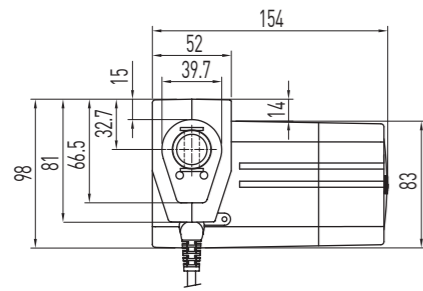
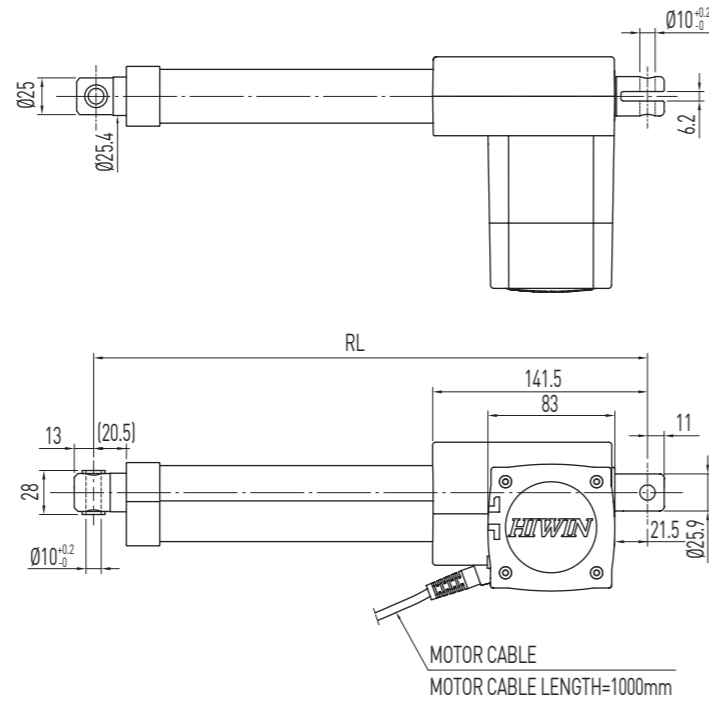
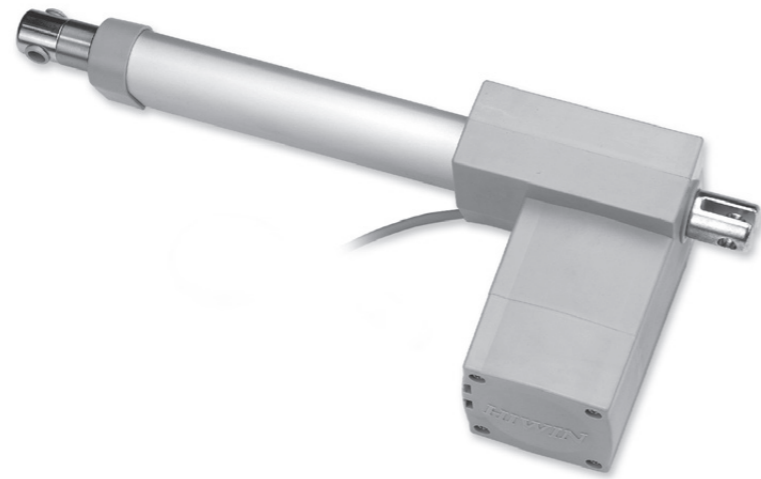

- RL = S+171
Stroke ≤ 300
- RL = S+221
Stroke = 350 and 400
- RL: Retracted length
- S: Stroke length

Table 2.5 Specifications

Screw type	ACME
Weight*	2.95kg
Protection	IP54
Compatible controller	Compatible with all controllers (*Notice the type of connector: Audio/DIN 4pin)
Working temp.	+5°C~40°C

* Stroke length 200mm

Option:

- (1) IP66
- (2) Safety Nut (RL = S+183, S ≤ 300 / RL = S+233, 350 and 400)
- (3) Back fixture turned 90°
- (4) Plug: DIN 4PIN plug / Stereo plug

Table 2.6 LAM3 Specifications

Model	Thrust max. (N)	Pulling max. (N)	Holding max. (N)	Speed (mm/s) Load = Max. / Load = 0	Standard stroke (mm) : S						Duty cycle %	Current max. (A)		
					100	150	200	250	300	350		400	12VDC	24VDC
LAM3-1	6000	5000	5000	4 / 5.5	100	150	200	250	300	350	400	10	12	6
LAM3-2	4000	4000	4000	5.5 / 7.5	100	150	200	250	300	350	400	10	10	5
LAM3-4	2000	2000	1500	11.5 / 14.5	100	150	200	250	300	350	400	10	8	4

*Min. input power = Voltage x Current max.

LAM3-1/-2/-4

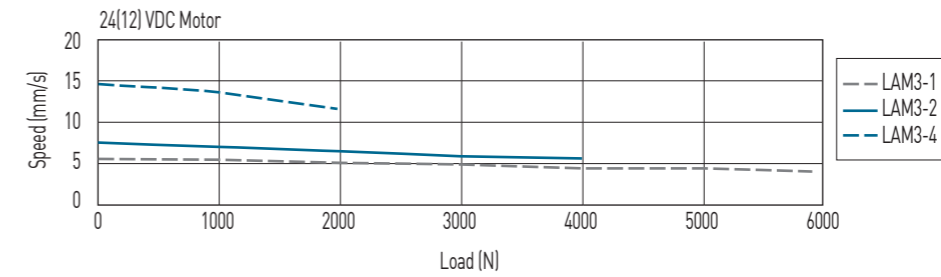

LAM3-1/-2/-4

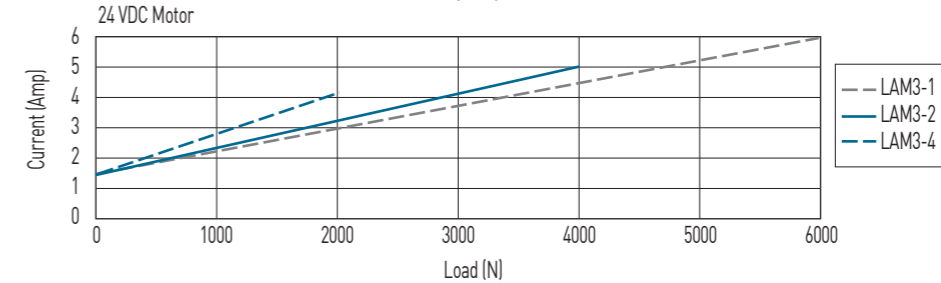

**Note: The test results are obtained by using the 24VDC power supply.

LAM3-1/-2/-4

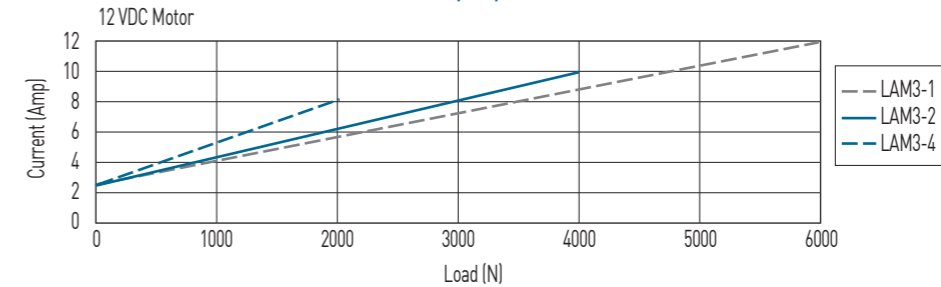

**Note: The test results are obtained by using the 12VDC power supply.

Ordering Information

LAM3 - 1 - 1 - 300 - 24 G E					
Model number	1 : Basic model complete with internal limit switches	Stroke length	Voltage 24:Standard motor 12:12VDC Standard	Color B : Black G : Gray	Special models according to the customer's requirement (Ignore this part of the serial number if not available)

Linear Actuator

3.LAS Series

3-1 HIWIN LAS Series (1)

LAS1

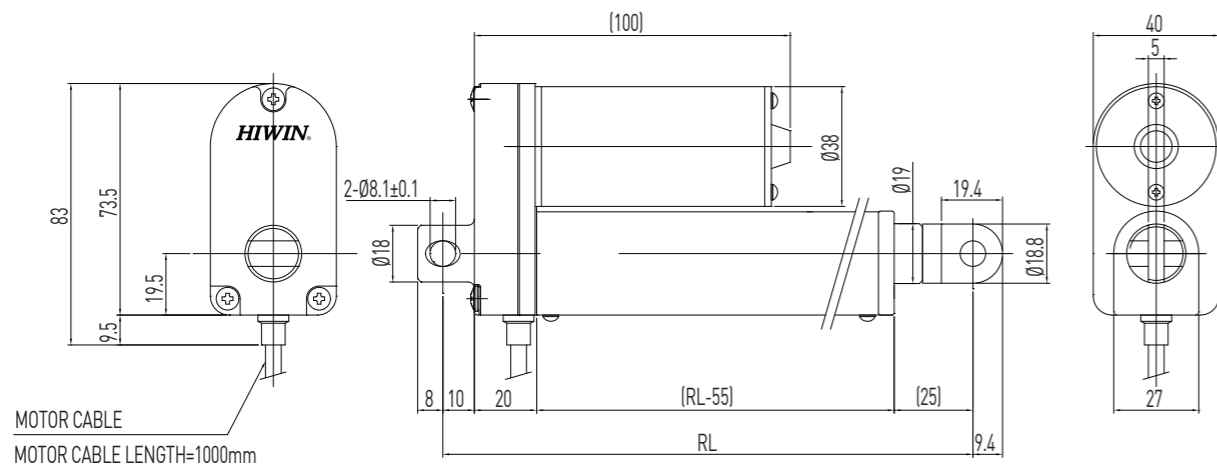

- RL = S+119
Stroke ≤ 250
- RL = S+169
Stroke = 300
- RL : Retracted length
- S : Stroke length

Table 3.1 Specifications

Screw type	ACME
Weight*	1.04kg
Protection	IP54
Compatible controller	Compatible with all controllers [*Notice the type of connector: Audio/DIN 4pin]
Working temp.	+5°C~40°C

* Stroke length 200mm

Option:

- (1) IP66
- (2) Back fixture turned 90°
- (3) Rod end with flat connector
(RL=S+110, S ≤ 250 / RL=S+160, S=300)
- (4) External reed switches
- (5) Plug : DIN 4PIN plug / Stereo plug
- (6) UL version

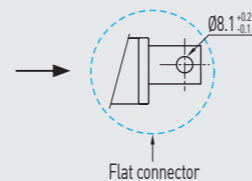
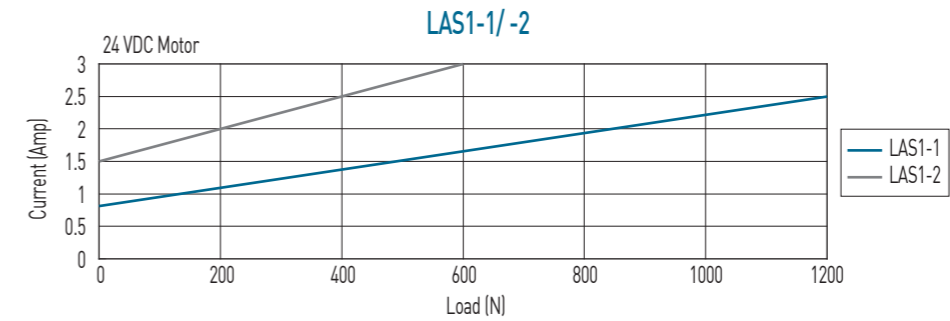
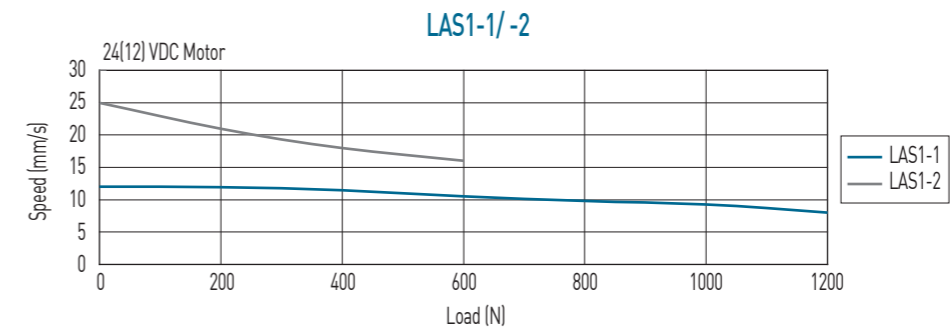

Table 3.2 LAS1 Specifications

Model	Thrust max. (N)	Pulling max. (N)	Holding max. (N)	Speed (mm / s) Load = Max. / Load = 0	Standard stroke (mm) : S								Duty cycle %	Current max. (A)	
					50	75	100	125	150	200	250	300		12VDC	24VDC
LAS1-1	1200	1200	800	8 / 12	50	75	100	125	150	200	250	300	10	6	2.5
LAS1-2	600	600	300	16 / 25	50	75	100	125	150	200	250	300	10	6	3

*Min. input power = Voltage x Current max.



**Note: The test results are obtained by using the 24VDC power supply.

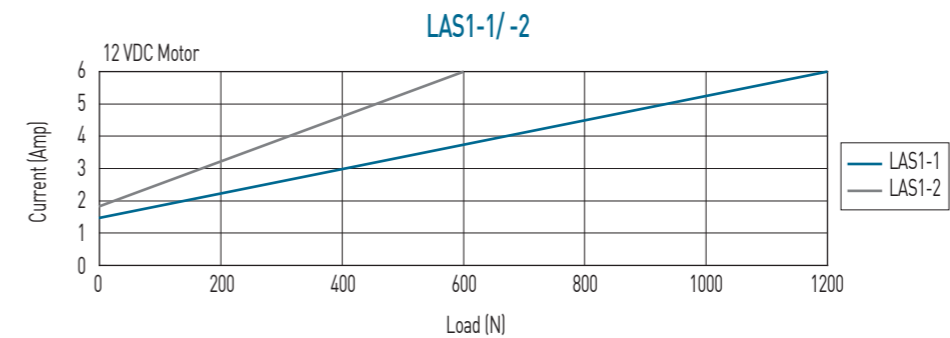

**Note: The test results are obtained by using the 12VDC power supply.

Ordering Information

LAS1 - 1 - 1 - 200 - 24 G E

Model number	1 : Basic model complete with internal limit switches	Stroke length	24:Standard motor 12:12VDC Standard	Voltage	Color B : Black G : Gray	Special models according to the customer's requirement (Ignore this part of the serial number if not available)
--------------	---	---------------	--	---------	--------------------------------	---

Linear Actuator

3-2. HIWIN LAS Series (2)

LAS2

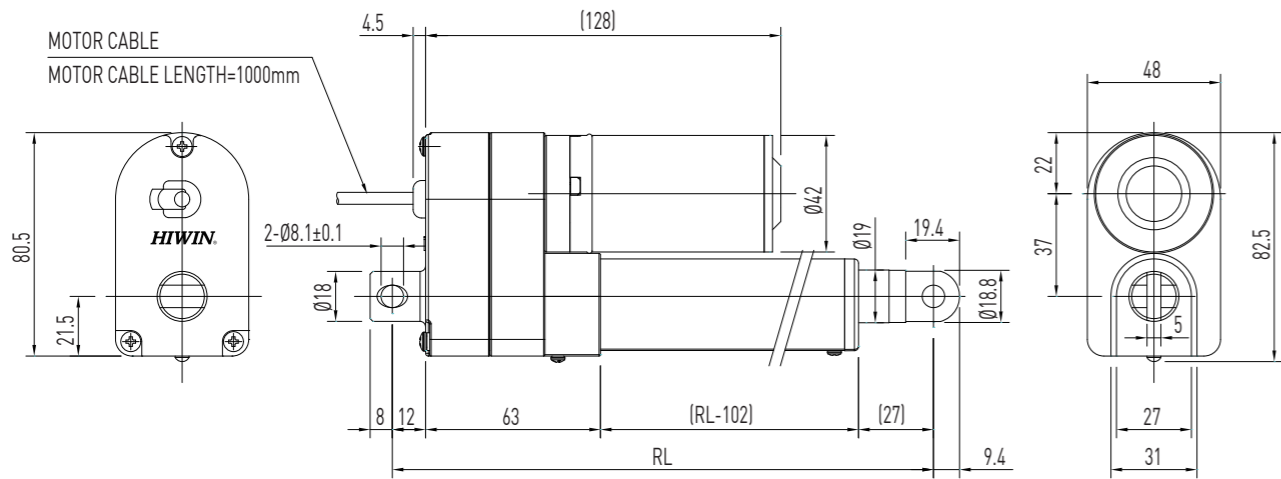

- RL = S+146
Stroke ≤ 250
RL: Retracted length
S: Stroke length

Table 3.3 Specifications

Screw type	ACME
Weight*	1.3kg
Protection	IP54
Compatible controller	Compatible with all controllers [*Notice the type of connector: Audio/DIN 4pin]
Working temp.	+5°C~40°C

* Stroke length 200mm

Option:

- (1) IP66
- (2) Position feedback
 - 1: Potentiometer 10k ohm (RL = S+154, S ≤ 250)
 - 2: Hall sensor:PNP[standard]
- (3) Back fixture turned 90°

Table 11.2 Position feedback specifications (Hall Sensor)

Supply voltage	24VDC	12VDC	5VDC
Output	High level 24VDC Low level 0.2V / 10mA sink (PNP)(NPN)	High level 12VDC Low level 0.2V / 10mA sink (PNP)(NPN)	TTL

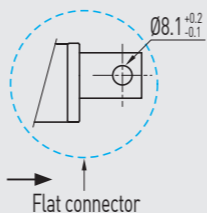

- (4) Rod end with flat connector (RL = S+133, S ≤ 250)
- (5) Plug: DIN 4PIN plug / Stereo plug
- (6) UL version
- (7) External reed switch(RL=S+174,S ≤ 250)

Table 3.4 LAS2 Specifications

Model	Thrust max. (N)	Pulling max. (N)	Holding max. (N)	Speed (mm / s) Load = Max. / Load = 0	Standard stroke (mm) : S					Duty cycle %	Current max. (A)		Hall Sensor Resolution (mm/pulse)	Potentiometer Resolution (Ohm/mm)
					50	100	150	200	250		12VDC	24VDC		
LAS2-1	1800	1200	1800	4.5 / 7	50	100	150	200	250	10	6	3	0.3175	21

*Min. input power = Voltage x Current max.

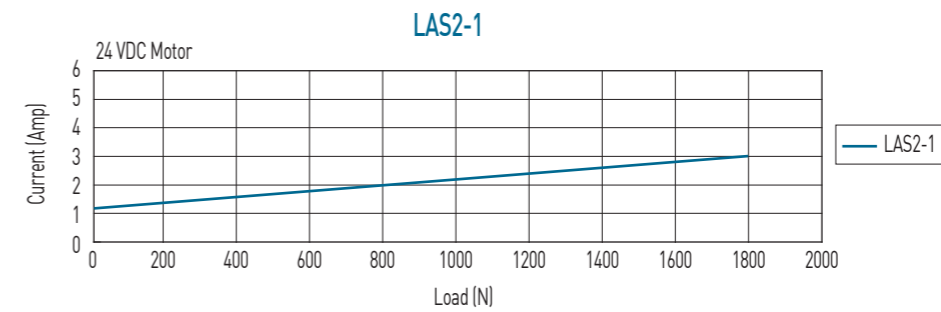
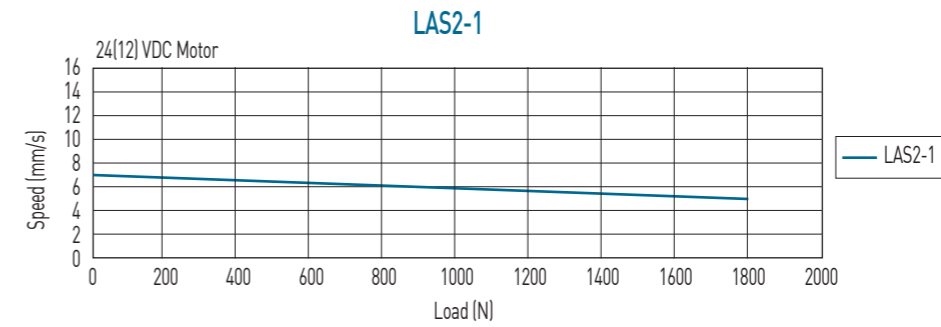

**Note: The test results are obtained by using the 24VDC power supply.

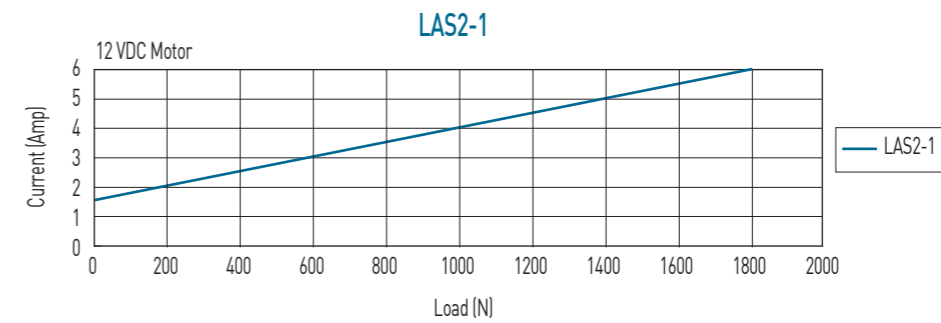

**Note: The test results are obtained by using the 12VDC power supply.

Ordering Information

Model number	LAS2 - 1 - 1 - 200 - 24 G E				Color	Special models according to the customer's requirement (Ignore this part of the serial number if not available)
	1 : Basic model complete with internal limit switches	Stroke length	Voltage	24:Standard motor 12:12VDC Standard	B : Black G : Gray	

Linear Actuator

3-3. HIWIN LAS Series (3)

LAS3

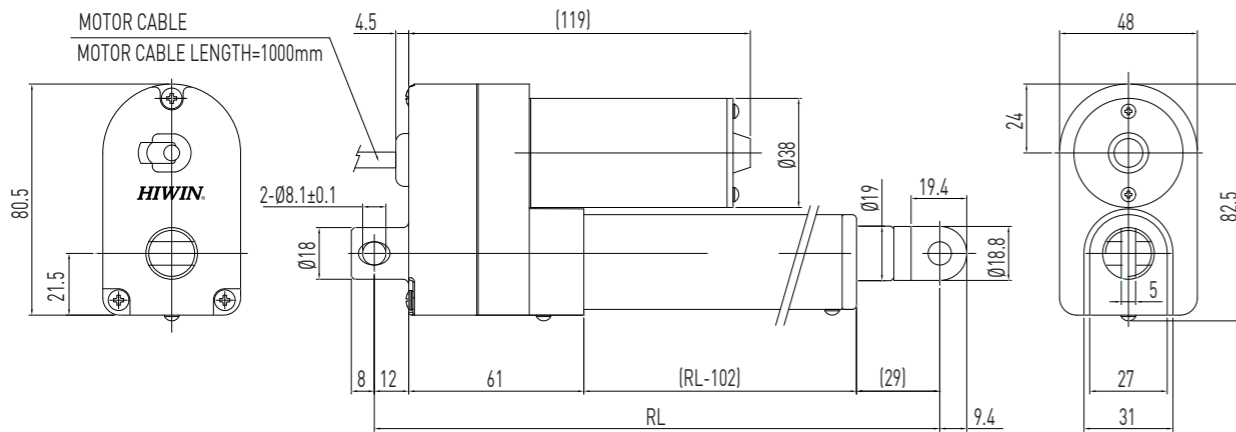

- RL = S+146
Stroke ≤ 250
RL: Retracted length
S: Stroke length

Table 3.5 Specifications

Screw type	ACME
Weight*	1.27kg
Protection	IP54
Compatible controller	Compatible with all controllers [*Notice the type of connector: Audio/DIN 4pin]
Working temp.	+5°C~40°C

* Stroke length 200mm

Option:

- (1) IP66
- (2) Position feedback
 - 1: Potentiometer 10k ohm (RL = S+154, S ≤ 250)
 - 2: Hall sensor:PNP[standard]

Table 12.2 Position feedback specifications (Hall Sensor)

Supply voltage	24VDC	12VDC	5VDC
Output	High level 24VDC Low level 0.2V / 10mA sink (PNP)(NPN)	High level 12VDC Low level 0.2V / 10mA sink (PNP)(NPN)	TTL

- (3) Back fixture turned 90°
- (4) Rod end with flat connector (RL = S+133, S ≤ 250)
- (5) Plug : DIN 4PIN plug / Stereo plug
- (6) External reed switch(RL=S+172,S<250)

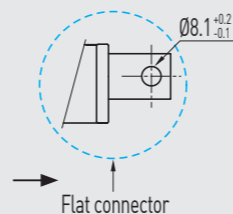
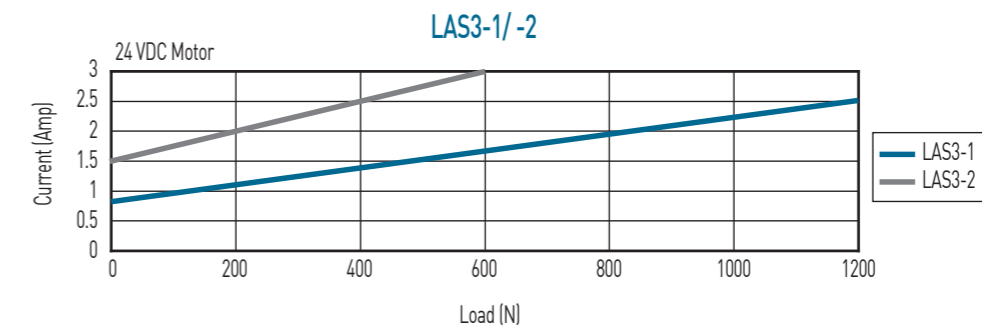
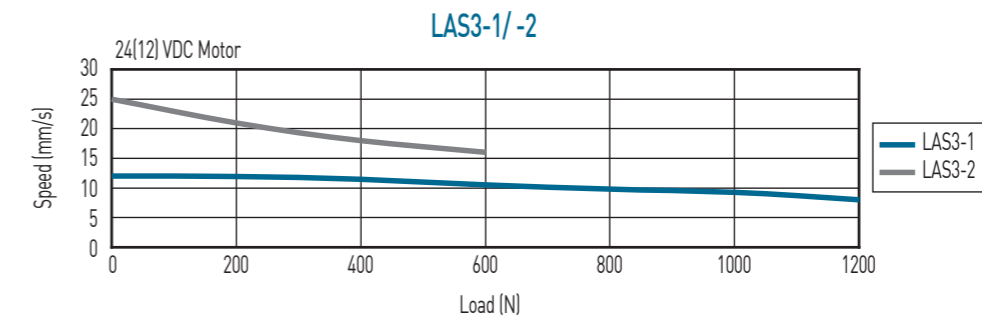

Table 3.6 LAS3 Specifications

Model	Thrust max. (N)	Pulling max. (N)	Holding max. (N)	Speed (mm / s) Load = Max. / Load = 0	Standard stroke (mm) : S					Duty cycle %	Current max. (A)		Hall Sensor Resolution (mm/pulse)	Potentiometer Resolution (Ohm/mm)
					50	100	150	200	250		12VDC	24VDC		
LAS3-1	1200	1200	800	8 / 12	50	100	150	200	250	10	6	2.5	0.3175	21
LAS3-2	600	600	300	16 / 25	50	100	150	200	250	10	6	3	0.635	10.5

*Min. input power = Voltage x Current max.



**Note: The test results are obtained by using the 24VDC power supply.

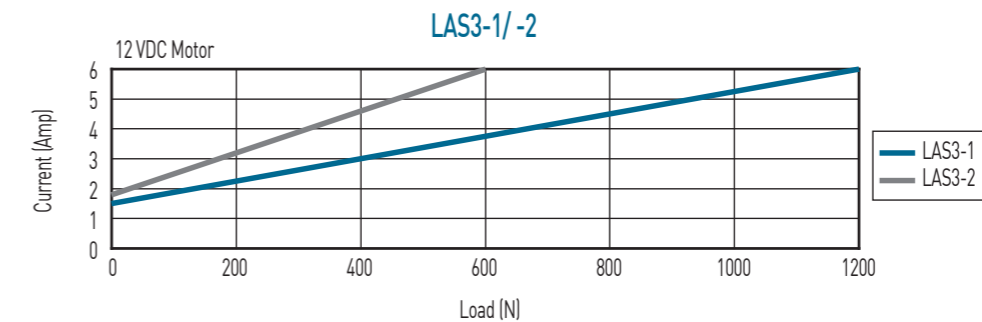

**Note: The test results are obtained by using the 12VDC power supply.

Ordering Information

Model number	LAS3 - 1 - 1 - 200 - 24 G E				Special models according to the customer's requirement (Ignore this part of the serial number if not available)
	1 : Basic model complete with internal limit switches	Stroke length	Voltage 24:Standard motor 12:12VDC Standard	Color B : Black G : Gray	

Linear Actuator

3-4. HIWIN LAS Series (4)

LAS4

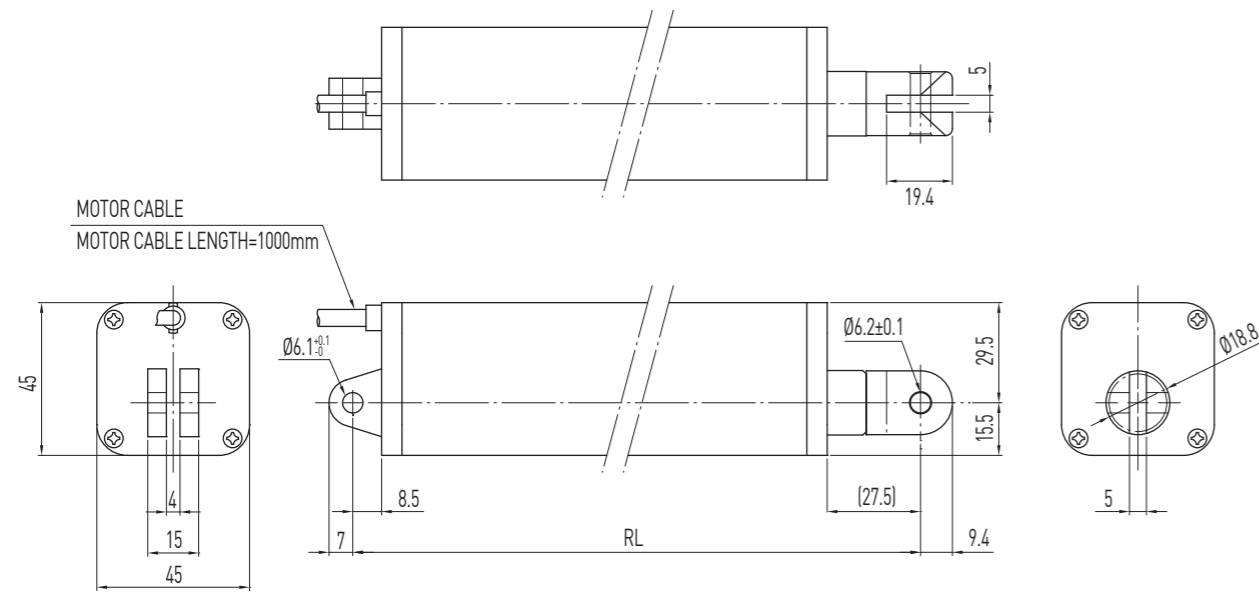

- RL = S+222.5
Stroke ≤ 300
RL: Retracted length
S: Stroke length

Table 3.7 Specifications

Screw type	ACME
Weight*	1.36kg
Protection	IP54
Compatible controller	Compatible with all controllers [*Notice the type of connector: Audio/DIN 4pin]
Working temp.	+5°C~40°C

* Stroke length 200mm

Table 13.2 Position feedback specifications (Hall Sensor)

Supply voltage	24VDC	12VDC	5VDC
Output	High level 24VDC Low level 0.2V / 10mA sink (NPN)	High level 12VDC Low level 0.2V / 10mA sink (NPN)	TTL

Option:

- (1) IP65
- (2) Hall sensor [RL = S+226, S ≤ 300]
- (3) Plug: DIN 4PIN plug/Stereo plug

Table 3.8 LAS4 Specifications

Model	Thrust max. (N)	Pulling max. (N)	Holding max. (N)	Speed (mm/s) Load = Max. / Load = 0	Standard stroke (mm) : S					Duty cycle %	Current max. (A)		Hall Sensor Resolution (mm/pulse)
					100	150	200	250	300		12VDC	24VDC	
LAS4-1	800	800	600	10 / 15	100	150	200	250	300	10	5	2.3	0.0085
LAS4-2	300	300	200	30 / 55	100	150	200	250	300	10	6	3.6	0.02

*Min. input power = Voltage x Current max.

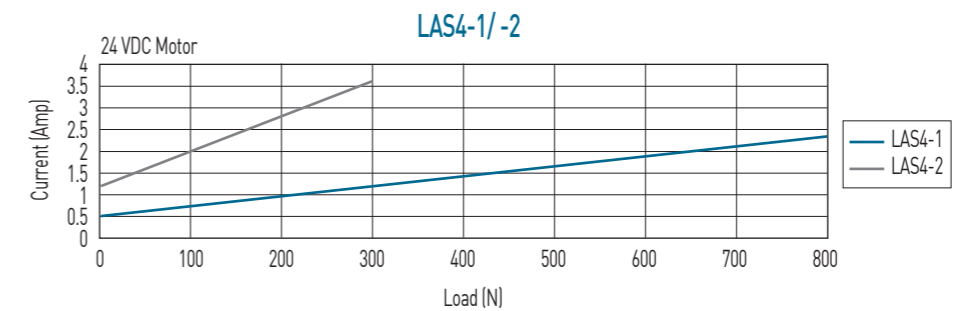
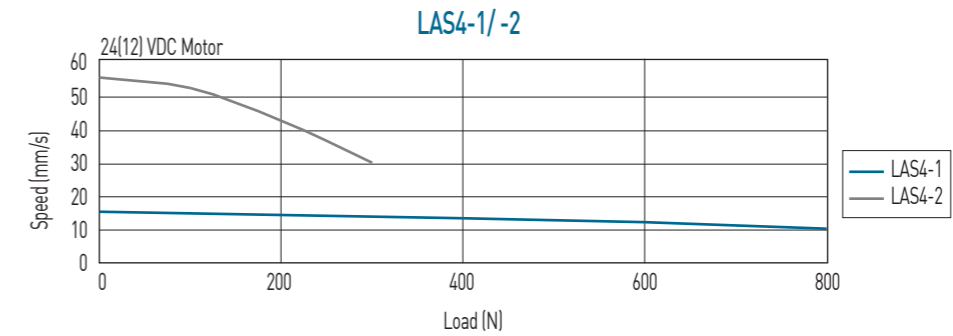

**Note: The test results are obtained by using the 24VDC power supply.

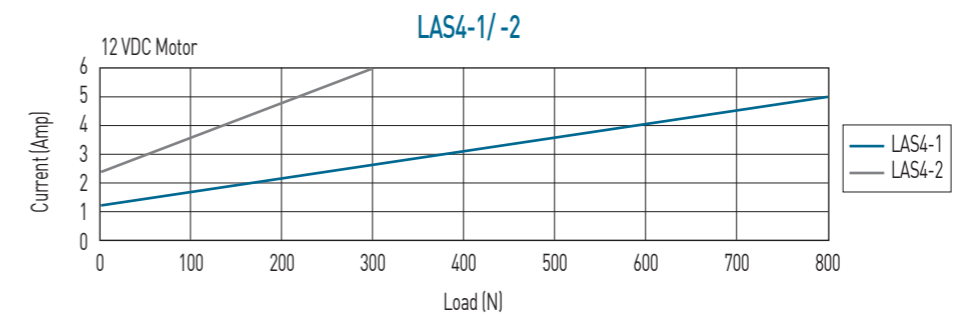

**Note: The test results are obtained by using the 12VDC power supply.

Ordering Information

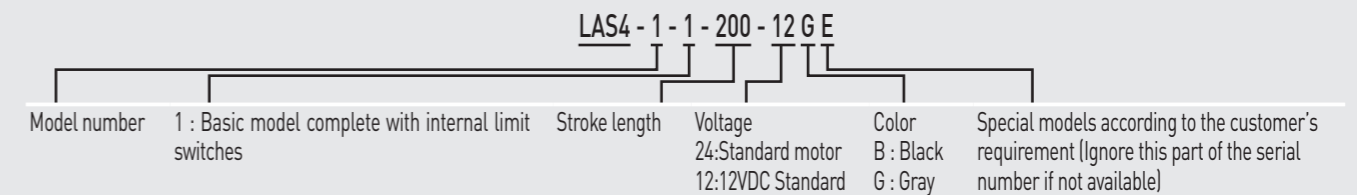

Linear Actuator

4.LAN Series

4-1. HIWIN LAN Series (1)

LAN1

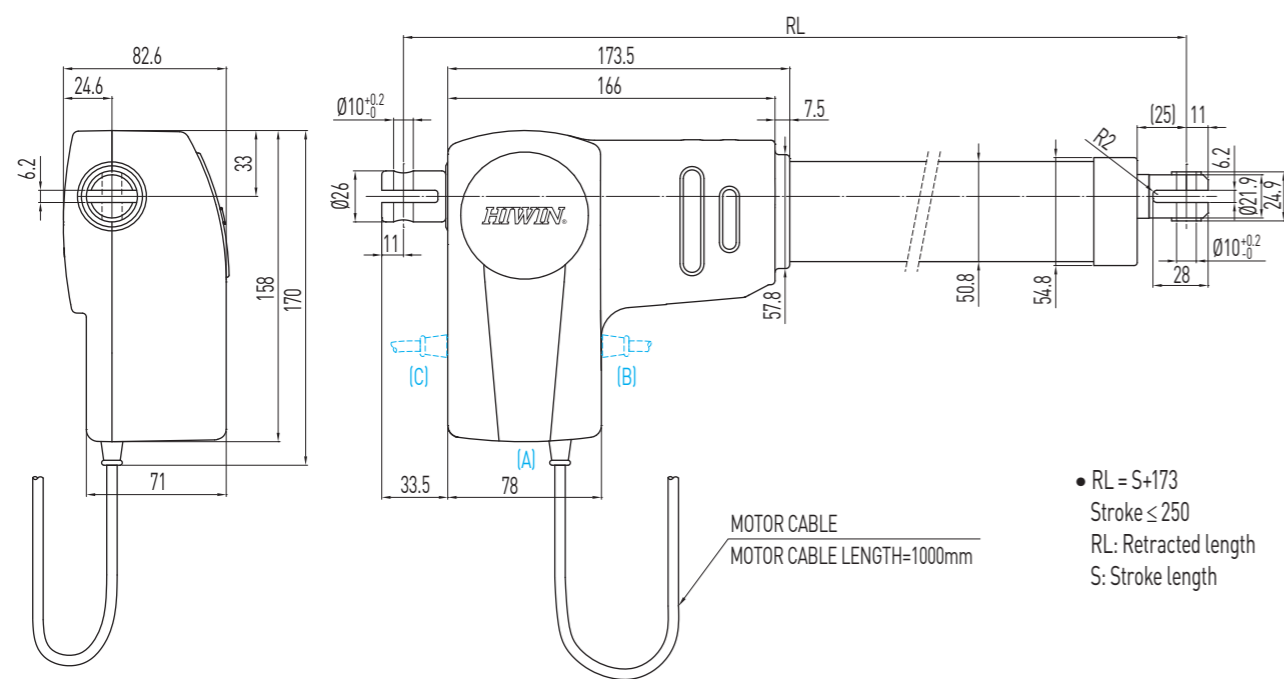

Table 4.1 Specifications

Screw type	ACME
Weight*	2.6kg
Protection	IP54
Compatible controller	Compatible with all controllers [*Notice the type of connector: Audio/DIN 4pin]
Working temp.	+5°C~40°C

* Stroke length 200mm

Option:

- (1) IP66
- (2) Position feedback
- (3) Safety Nut (RL = S+185, S ≤ 250)
- (4) Mechanical Spline (push only) (RL = S+223, S ≤ 250)

Table 4.2 Position feedback specifications (Hall Sensor)

Supply voltage	12VDC	5VDC
Output	High level 12VDC	TTL
	Low level 0.2V / 10mA sink (NPN)	

- (5) Back fixture turned 90°
- (6) Motor cable outlet: (A)Standard (B)Front (C)Back.
- (7) UL version
- (8) Plug: DIN 4PIN plug / Stereo plug

Table 4.3 12VDC Motor

Model	Thrust max. (N)	Pulling max. (N)	Holding max. (N)	Speed (mm/s) Load = Max. / Load = 0	Standard stroke (mm) : S	Duty cycle %	Current max. (A) 12VDC	Hall Sensor Resolution (mm/pulse)
LAN1-1	5000	5000	5000	3 / 6	100 150 200 250	10	11	0.3
LAN1-2	4000	4000	4000	4 / 8	100 150 200 250	10	11	0.4
LAN1-3	3000	3000	3000	5 / 10	100 150 200 250	10	10	0.5

**Note: The test results are obtained by using the 12VDC power supply and holding by motor short-circuited.

*Min. input power = Voltage x Current max.

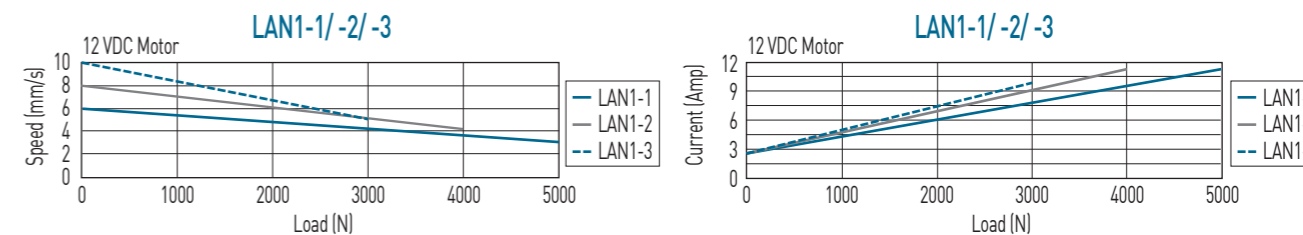

Ordering Information

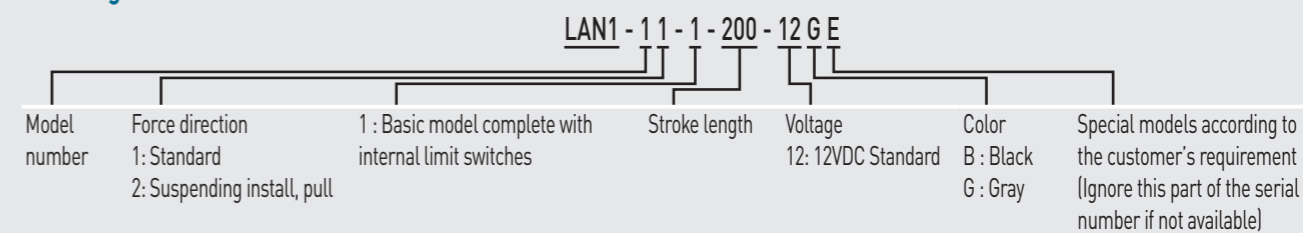

Linear Actuator

4-2. HIWIN LAN Series (2)

LAN3A

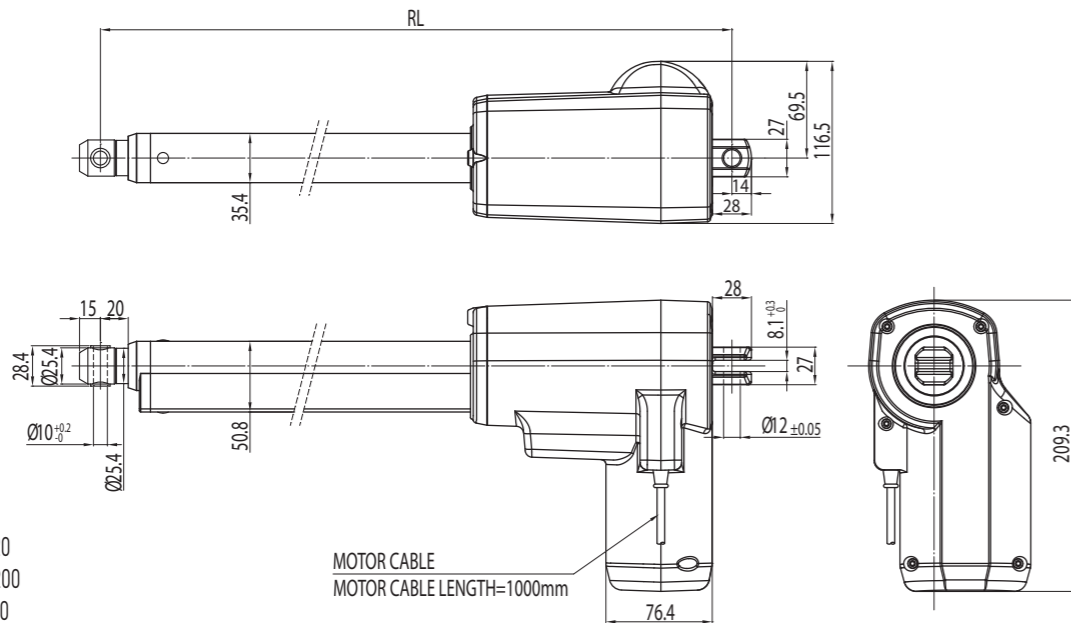

- RL = S+220
Stroke < 200
RL = S+260
Stroke: 200-500mm
RL: Retracted length
S: Stroke length

Table 4.4 Specifications

Screw type	ACME
Weight*	5.2kg
Protection	IP54
Compatible controller	LAK6B / LAK2J
Working temp.	+5°C-40°C

* Stroke length 200mm

Apply:

Large thrust with (1.2Nt)

Option:

- (1) IP66
- (2) Potentiometer 10K ohm (RL = S+231, S < 200mm / RL = S+271, S: 200-500mm)
* The max. stroke lengths with potentiometer: LAN3A-1 Max.280mm, LAN3A-2 Max.400mm, LAN3A-3 Max.450mm, LAN3A-4 Max.500mm
- (3) Mechanical Spline(push only) (RL = S+262, S < 200mm / RL = S+302, S: 200-500mm)
- (4) Safety Nut (RL = S+232, S < 200mm / RL = S+272, S: 200-500mm);
Safety Nut+Mechanical Spline (RL = S+269, S < 200mm / RL = S+309, S = 200-500mm)
- (5) Mechanical quick release(Thrust only, pulling is not allowable)
- (6) Back fixture turned 90°
- (7) Fast motor 24Q
- (8) External reed switches (RL = S+300, S < 200mm / RL = S+340, S = 200-500mm)
- (9) MR Sensor feedback
- (10) Plug: DIN 4PIN plug / Stereo plug
- (11) UL Version

Table 4.5 LAN3A Specifications

Model	Thrust max. (N)	Pulling max. (N)	Holding max. (N)	Speed (mm/s) Load = Max. / Load = 0	Standard stroke (mm) : S	Duty cycle %	Current max. (A) 24VDC	Potentiometer Resolution (Ohm/mm)	MR Sensor Resolution (mm/pulse)
LAN3A-1	12000	6000	12000	3/5	100 150 200 250 300 350 - - -	10	8.3	33.3	0.1
LAN3A-2	10000	6000	10000	4.5/8	100 150 200 250 300 350 400 - - -	10	8.3	22.2	0.16
LAN3A-3	7000	6000	7000	7/9	100 150 200 250 300 350 400 450 - - -	10	8	16.7	0.22
LAN3A-4	5000	5000	5000	9.5/12.5	100 150 200 250 300 350 400 450 500	10	7	13.3	0.27

* Min. input power = Voltage x Current max.

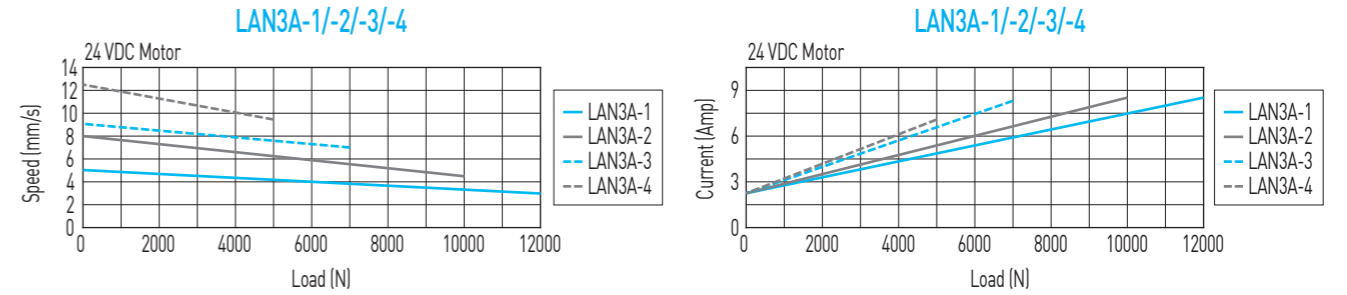

**Note: The test results are obtained by using the 24VDC power supply and holding by motor short-circuited.

Table 4.6 LAN3A (Fast Motor 24Q)

Model	Thrust max. (N)	Pulling max. (N)	Holding max. (N)	Speed (mm/s) Load = Max. / Load = 0	Standard stroke (mm) : S	Duty cycle %	Current max. (A) 24VDC	Potentiometer Resolution (Ohm/mm)	MR Sensor Resolution (mm/pulse)
LAN3A-1	12000	6000	12000	4.5/7	100 150 200 250 300 350 - - -	10	12	33.3	0.1
LAN3A-2	10000	6000	10000	7/11	100 150 200 250 300 350 400 - - -	10	12	22.2	0.16
LAN3A-3	7000	6000	7000	9/13	100 150 200 250 300 350 400 450 - - -	10	12	16.7	0.22
LAN3A-4	5000	5000	5000	13/18	100 150 200 250 300 350 400 450 500	10	12	13.3	0.27

* Min. input power = Voltage x Current max.

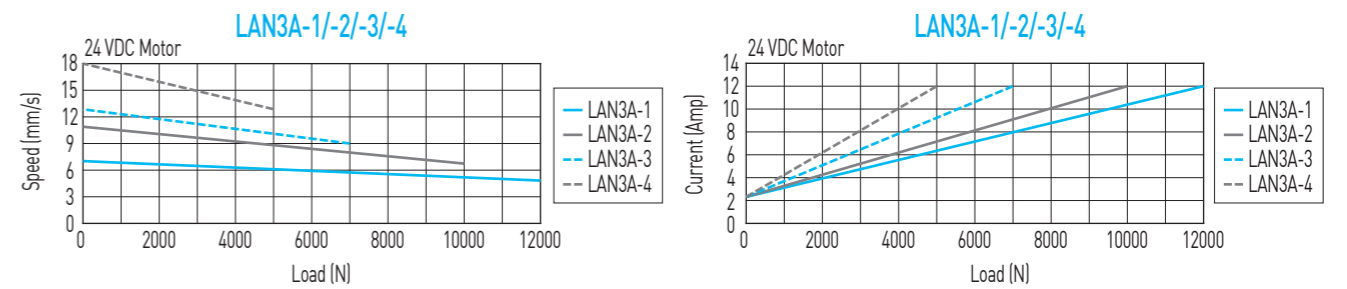

**Note: The test results are obtained by using the 24VDC power supply and holding by motor short-circuited.

Ordering Information

Model number	Force direction 1: Standard 2: Suspending install, pull	1: Basic model complete with internal limit switches	Stroke length	Voltage 24: Standard motor 24Q: Fast motor	Color B: Black G: Gray	Special models according to the customer's requirement (Ignore this part of the serial number if not available)
--------------	---	--	---------------	--	------------------------------	---

LAN3A - 1 1 - 1 - 200 - 24 G E

Linear Actuator

4-3. HIWIN LAN Series (3)

LAN4

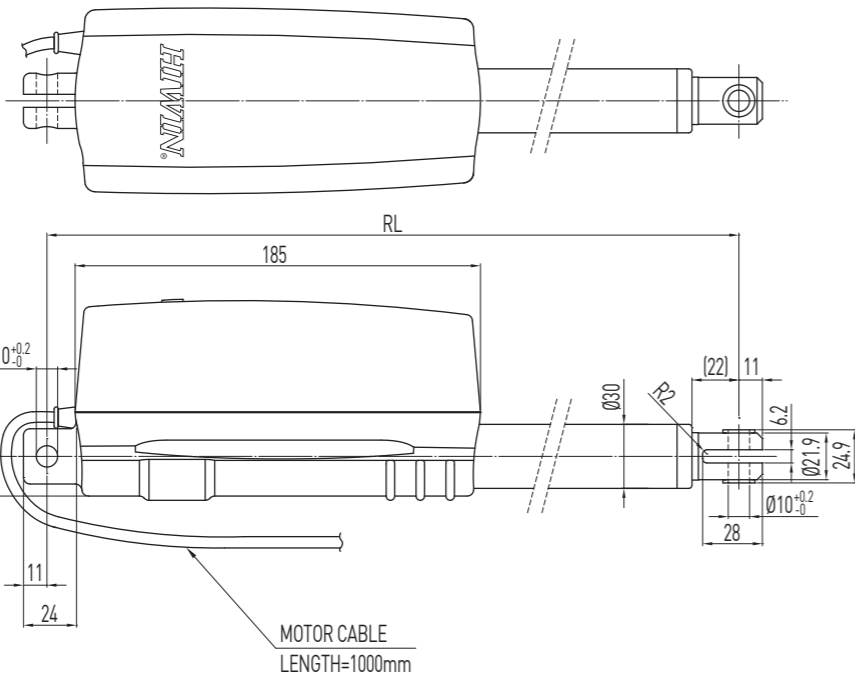

- RL = S+160
Stroke ≤ 400
RL: Retracted length
S: Stroke length

Table 4.7 Specifications

Screw type	ACME
Weight*	2.33kg
Protection	IP54
Compatible controller	LAK2 / LAK2LN / LAK2D / LAK2BN / LAK2J / LAK6B
Working temp.	+5°C~40°C

* Stroke length 200mm

Option:

- (1) IP66
- (2) Safety Nut RL = S+174, S ≤ 400
- (3) Mechanical spline (push only) RL = S+200, S ≤ 400
- (4) Plug: DIN 4PIN plug / Stereo plug
- (5) UL Version

Table 4.8 LAN4 Specifications

Model	Thrust max. (N)	Pulling max. (N)	Holding max. (N)	Speed (mm/s) Load = Max. / Load = 0	Standard stroke (mm) : S								Duty cycle %	Current max. (A)	
					100	150	200	250	300	350	400	24VDC		12VDC	
LAN4-1	3500	3500	3500	3.5/7	100	150	200	250	300	350	400	10	6	12	
LAN4-2	3000	3000	3000	4.2/9	100	150	200	250	300	350	400	10	6	12	
LAN4-3	2000	2000	2000	6/13	100	150	200	250	300	350	400	10	5	12	
LAN4-4	1500	1500	1500	8.5/20	100	150	200	250	300	350	400	10	5	12	

* Min. input power = Voltage x Current max.

LAN4-1/-2/-3/-4

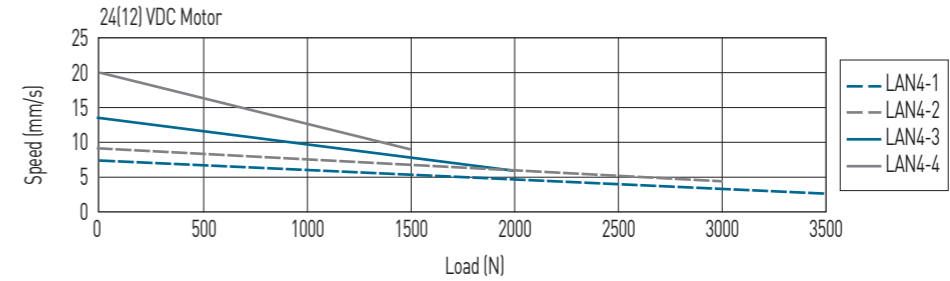

LAN4-1/-2/-3/-4

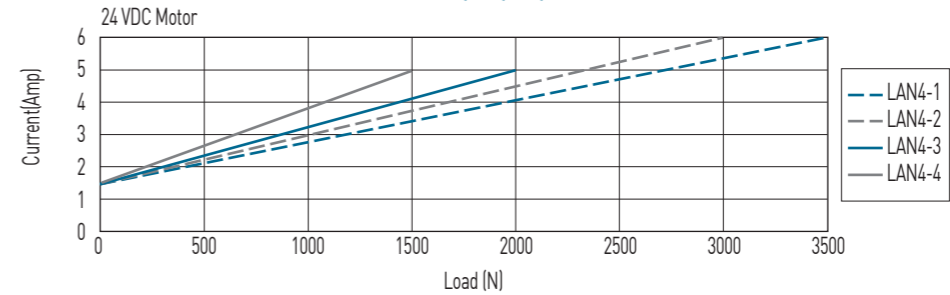

**Note: The test results are obtained by using the 24VDC power supply.

LAN4-1/-2/-3/-4

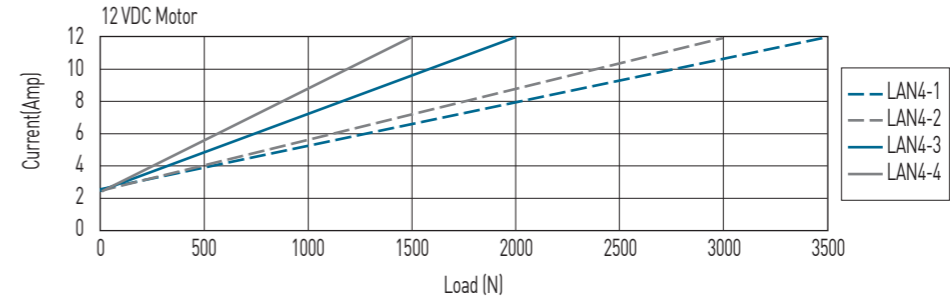

**Note: The test results are obtained by using the 12VDC power supply.

Ordering Information

LAN4 - 1 - 0 - 300 - 24 G E					
Model number	0: Basic model *1: Over-Current protection	Stroke length	Voltage 24: Standard motor 12: 12VDC Standard	Color B: Black G: Gray	Special models according to the customer's requirement (Ignore this part of the serial number if not available)

* Remark: The over-current protection is for over load protection, do not use for limit stop.
Suggestion: To add external limit switch as limit positions stop.

Linear Actuator

4-4. HIWIN LAN Series (4)

LAN5



- LAN5-1(24V/24Q)
RL=S+163
Stroke \leq 200
RL:Retracted length
S:Stroke length
- LAN5-2(24V/24Q)
RL=S+163
Stroke \leq 250
RL:Retracted length
S:Stroke length
- LAN5-3/-4(24V/24Q)
RL=S+163
Stroke \leq 300
RL:Retracted length
S:Stroke length

Quick release function:

- (1) The quick release cable can be pulled while the load on actuator under 100N.
- (2) When the quick release is activated, the actuator must have a load over 700N to ensure the actuator runs inwards.
- (3) After quick release activated, it may be necessary to run the actuator inwards.

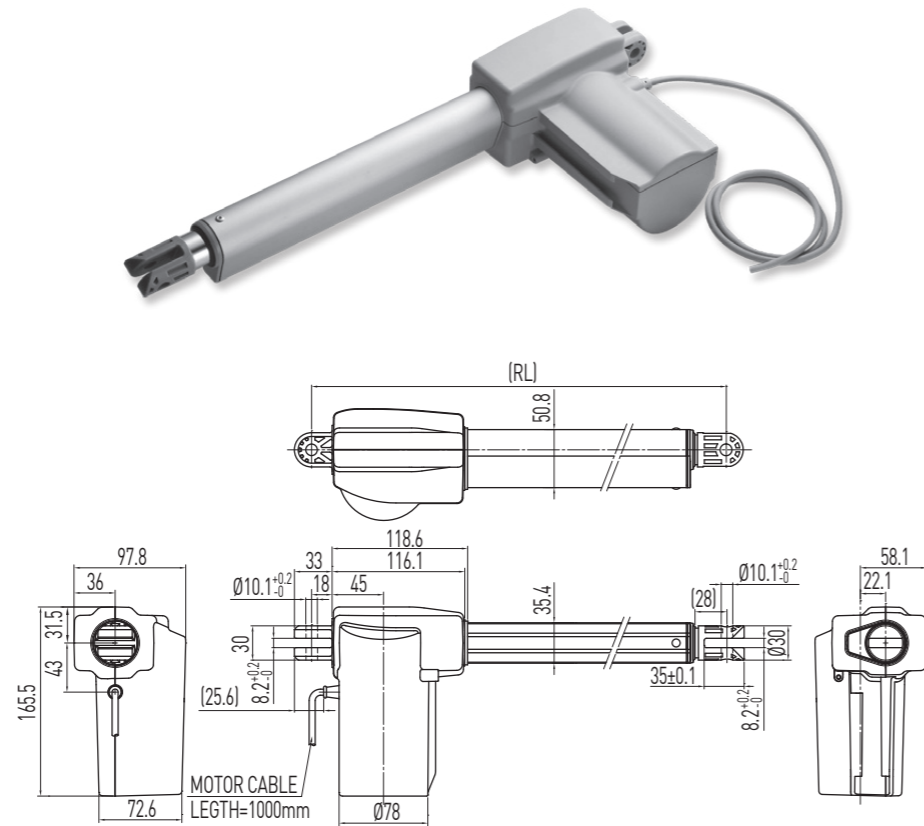

QUICK RELEASE

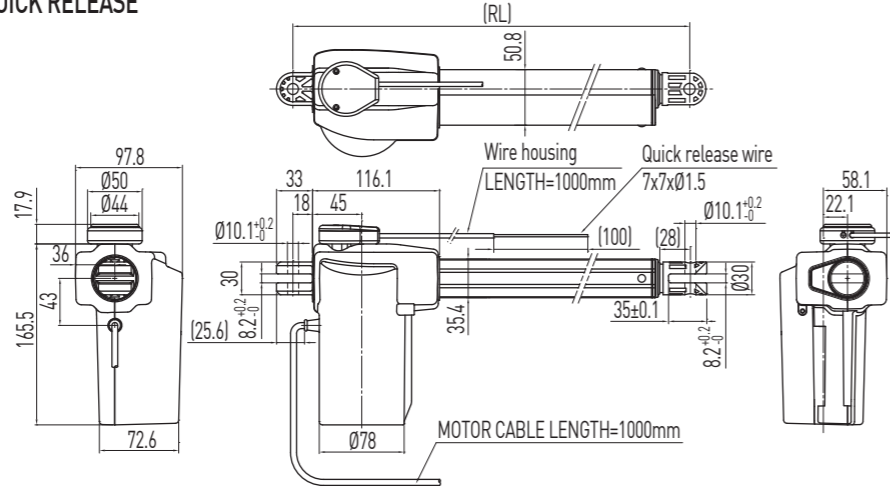

Table 4.9 Specifications

Screw type	ACME
Weight*	1.96kg
Protection	IP54
Compatible controller	Compatible with all kinds of controller [*Notice the type of connector: Audio/DIN 4PIN]
Working temp.	+5°C~40°C

* Stroke length 200mm

Option:

- | | | |
|-----------------------------------|---|---------------------------------------|
| (1) Hall Sensor | (4) Back fixture turned 0°, 45°, 90°, 135° | (7) UL version |
| (2) Safety nut | (5) IP65; IP66 | (8) Plug: DIN 4PIN plug / Stereo plug |
| (3) Mechanical Spline (push only) | (6) Quick release (For LAN5-3, LAN5-4 only) | |

Table 4.10 Position feedback specifications (Hall Sensor)

Supply voltage	24VDC	5VDC
Output	High level 24VDC	TTL
	Low level 0.2V / 10mA sink (NPN)	

Table 4.11 LAN5 Specifications

Model	Thrust max. (N)	Pulling max. (N)	Holding max. (N)	Speed (mm / s) Load = Max. / Load = 0	Standard stroke (mm) : S	Duty cycle %	Current max. (A) 24VDC	Hall Sensor Resolution (mm/pulse)
LAN5-1	8000	4000	6000	2 / 3.5	100 150 200 -	-	5	0.08
LAN5-2	6000	4000	5000	3 / 4.5	100 150 200 250	-	4.5	0.10
LAN5-3	4000	3000	4000	4 / 5.5	100 150 200 250	300	4	0.14
LAN5-4	3000	2000	1500	6 / 9	100 150 200 250	300	4	0.22

* When the stroke of LAN5-1 is between 250mm and 300mm, refer to the diagram on the right for max. load.
* LAN5-4 24V Quick release Holding max. 1000N

* LAN5-3 24V Quick release Holding max. 3000N
* Min. input power = Voltage x Current max.

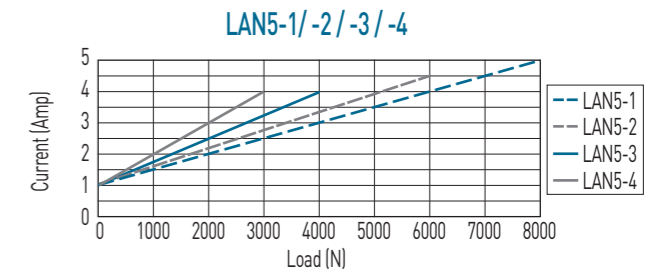
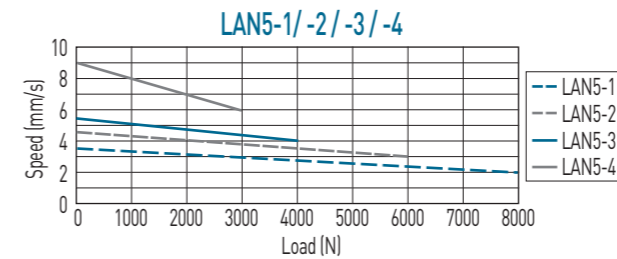

**Note: The test results are obtained by using the 24VDC power supply.

Table 4.12 LAN5(24Q) Specifications

Model	Thrust max. (N)	Pulling max. (N)	Holding max. (N)	Speed (mm / s) Load = Max. / Load = 0	Standard stroke (mm) : S	Duty cycle %	Current max. (A) 24VDC	Hall Sensor Resolution (mm/pulse)
LAN5-1	7000	4000	6000	5 / 7	100 150 200	10	8	0.08
LAN5-2	6000	4000	5000	7 / 9	100 150 200 250	10	8	0.10
LAN5-3	4000	3000	4000	9 / 11	100 150 200 250	300	6	0.14
LAN5-4	3000	2000	1500	14 / 19	100 150 200 250	300	6	0.22

* When the stroke of LAN5-1 is between 250mm and 300mm, refer to the diagram on the right for max. load.
* LAN5-4 24Q Quick release Holding max. 1000N

* LAN5-3 24Q Quick release Holding max. 3000N
* Min. input power = Voltage x Current max.

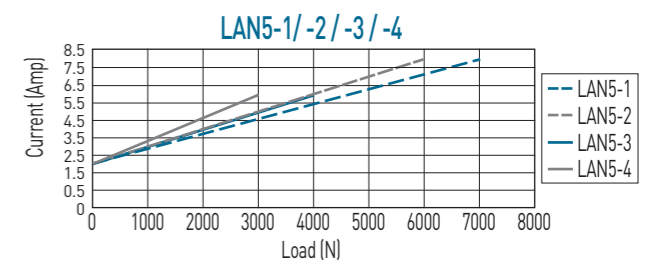
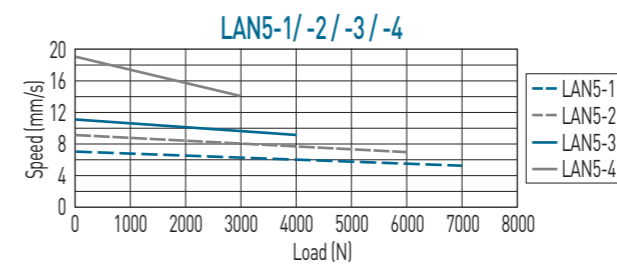

Ordering Information

LAN5 - 1 1 - 1 - 200 - 24 G E

Model number	Force direction 1: Standard 2: Suspending install, pull	1: Basic model complete with internal limit switches	Stroke length	Voltage 24: Standard motor 24Q: Fast motor	Color B: Black G: Gray	Special models according to the customer's requirement (Ignore this part of the serial number if not available)
--------------	---	--	---------------	--	------------------------------	---

Linear Actuator

5.LAC Series

5-1. HIWIN LAC Series (1)

LAC1

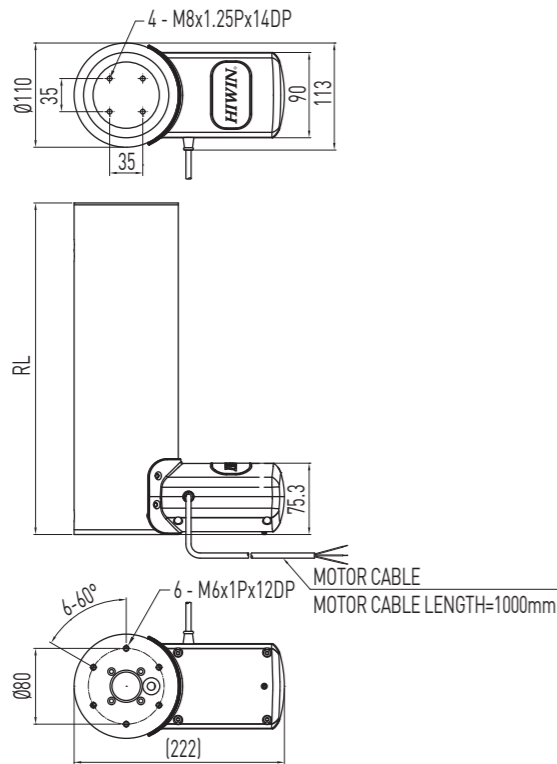

- RL:
Stroke ≤ 300, RL=310
Stroke 301-400, RL=360
Stroke 401-500, RL=410
RL=Retracted length
S:Stroke length

Table 5.1 Specifications

Screw type	ACME
Weight*	5.6kg
Protection	IP54
Compatible controller	Compatible with all controllers [*Notice the type of connector: Audio/DIN 4pin]
Working temp.	+5°C~40°C

* Stroke length 400mm

Option:

- (1) Hall sensor
- (2) Potentiometer 10k ohm
- (3) Plug : DIN 4PIN plug / Stereo plug
- (4) UL version

Table 5.2 LAC1 Specifications

Model	Thrust max. (N)	Pulling max. (N)	Holding max. (N)	Speed (mm / s) Load = Max. / Load = 0	Standard stroke (mm) : S	Duty cycle %	Current max. (A) 24VDC	Potentiometer Resolution (ohm/mm)	Hall Sensor Resolution (mm/pulse)
LAC1-1	2000	500	2000	8 / 12	300 400 500	10	5	6.67	0.064

* Min. input power = Voltage x Current max.

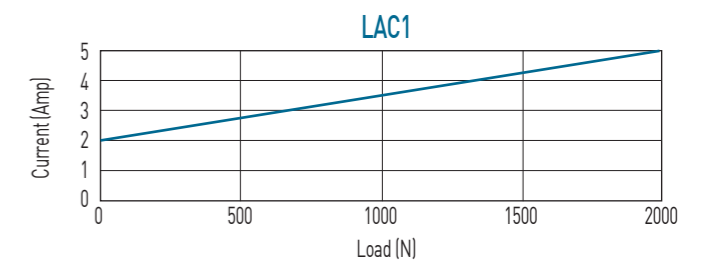
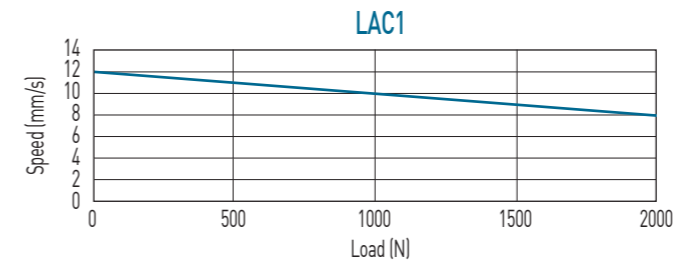

**Note: The test results are obtained by using the 24VDC power supply.

Table 5.3 LAC1(24Q) Specifications

Model	Thrust max. (N)	Pulling max. (N)	Holding max. (N)	Speed (mm / s) Load = Max. / Load = 0	Standard stroke (mm) : S	Duty cycle %	Current max. (A) 24VDC	Potentiometer Resolution (ohm/mm)	Hall Sensor Resolution (mm/pulse)
LAC1-1	2000	500	2000	13/16	300 400 500	10	8	6.67	0.064

* Min. input power = Voltage x Current max.

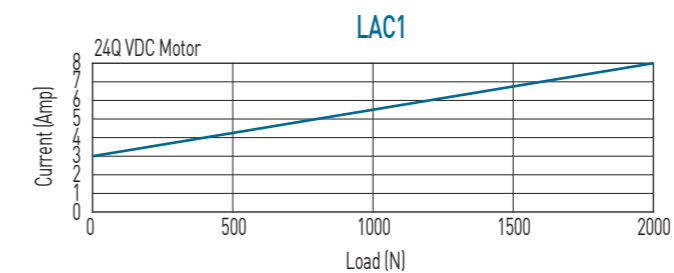
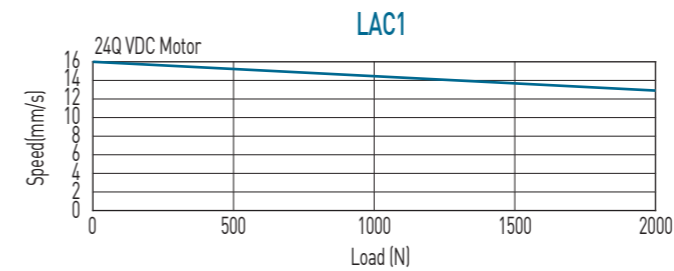

LAC1 Bending moment illustration

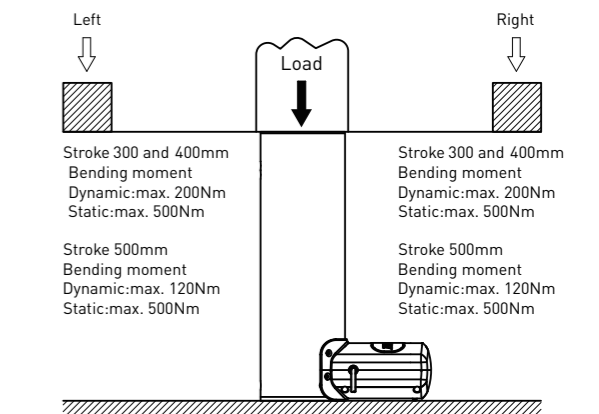

Ordering Information

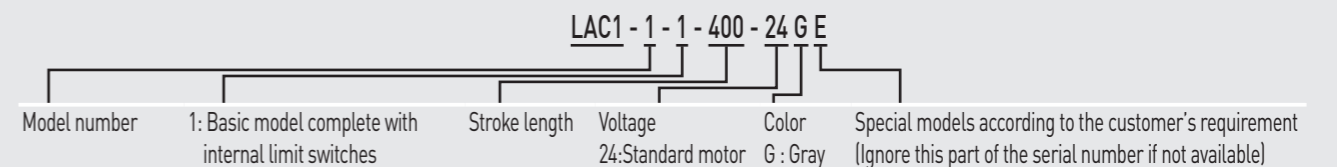

Linear Actuator

6. 1-Axis Controller

6-1. HIWIN 1-Axis Controller

LAK2LN

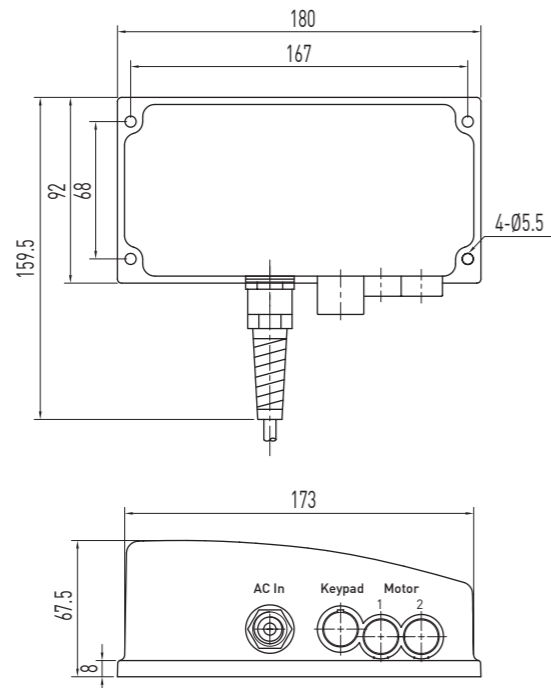

Table 6.1 Specifications

Input voltage	AC 100 / 110 / 220 / 230V(50/60Hz)
Output power	108VA (24VDC) max.
Duty cycle	10%
Protection	IP54
Working temp.	+5°C~40°C

Option:

IP66

Features of the LAK2LN

- Controls 1 linear Actuator
- Controls 1 Actuator with external limit switches
- OLP (Over Load Protection)
- Standard cable length: 4M
- Electronic protection for the relays

For Series LAM1 completed with external limit switches

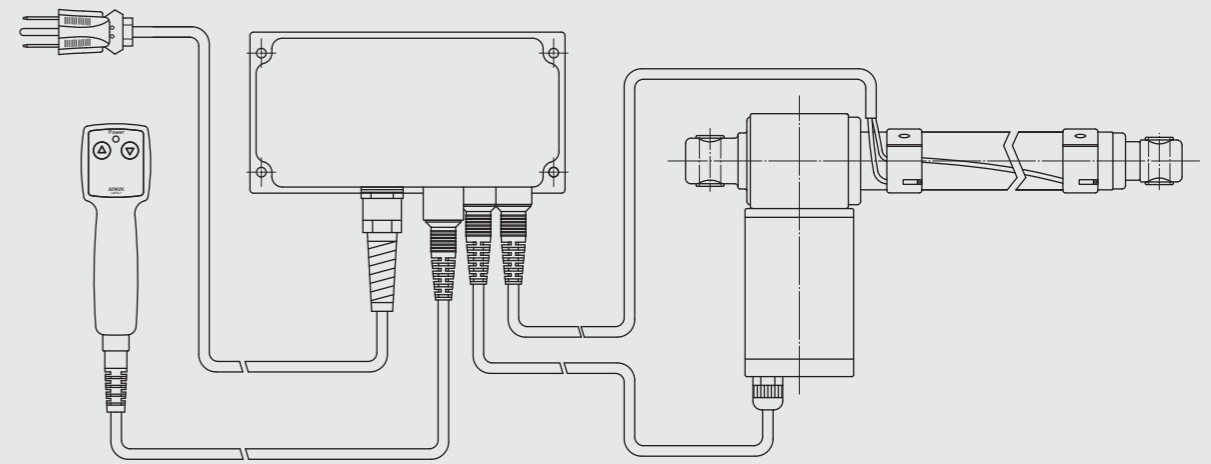

Ordering Information

LAK2LN - G - 110 - B E			
Actuator No. 1	Input Voltage	Color	Special models according to Client's requirement
G: Over current setting value	100: AC100V; 110: AC110V 220: AC220V; 230: AC230V	B: Black G: Gray	None E = Special requirement

- * Check attached table for over current setting...see page 55.
- * The keypad of the LAK2LN is not the same as LAK2.

Linear Actuator

7. 2-Axis Controller

7-1. HIWIN 2-Axis Controller (1)

LAK2

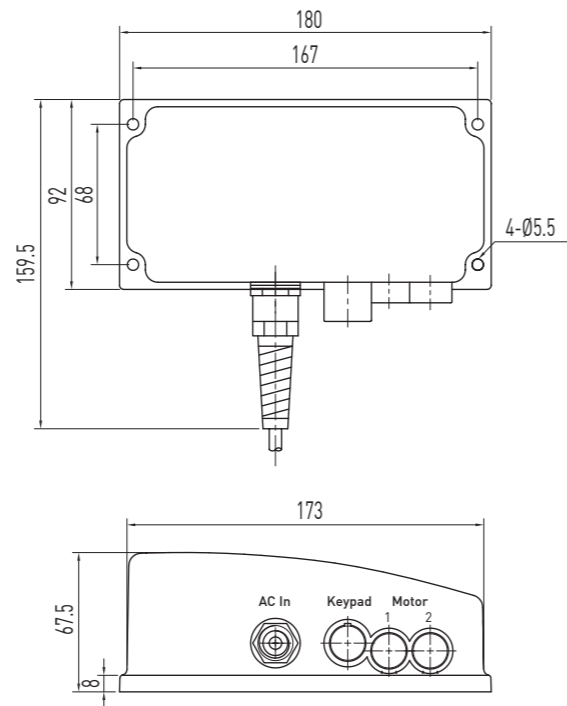

Table 7.1 Specifications

Input voltage	AC 100 / 110 / 220 / 230V (50/60Hz)
Output power	108VA (24VDC) max.
Duty cycle	10%
Protection	IP54
Working temp.	+5°C~40°C

Option:

- (1) IP66
- (2) DC 12V In & Out
- (3) DC 24V In & Out
- (4) UL version only for AC 120V input (Max. Output 24V/6A)

Features of the LAK2

- Control 1 or 2 Linear Actuators
- Over load protection
- Standard cable length: AC:4M/DC:1M
- Electronic protection of the relays

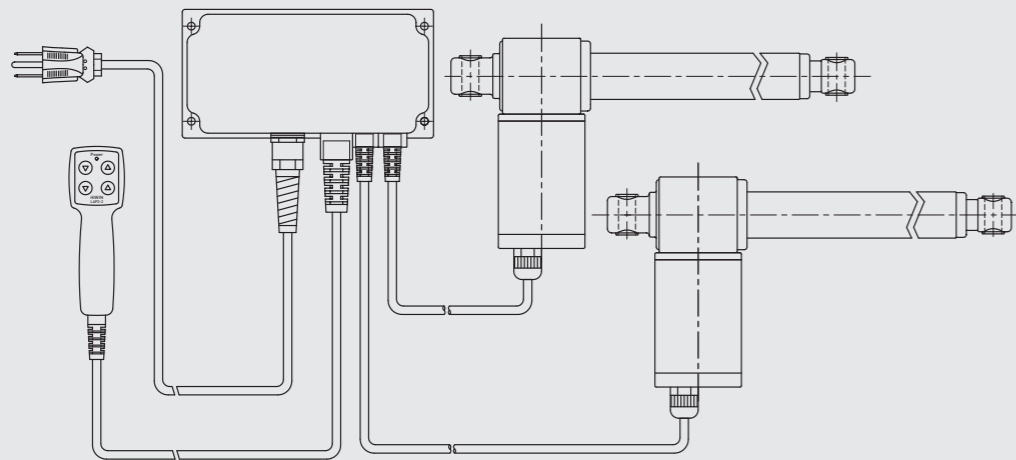

Ordering Information (AC Power)

LAK2 - B0 - 110 - B E			
Actuator No. 1-2	Input Voltage	Color	Special models according to Client's requirement
A-G: Over current setting value	100: AC100V; 110: AC110V 220: AC220V; 230: AC230V	B: Black G: Gray	None E = Special requirement

* Check attached table for over current setting...see page 55.

Ordering Information (DC Power)

LAK2 - E0 - 12 - B E			
Actuator No. 1-2	Input Voltage	Color	Special models according to Client's requirement
A-L: Over current setting value	12: 12VDC 24: 24VDC	B: Black G: Gray	None E = Special requirement

* Standard cable: 1M in length with 3 flying lead termination.

* Check attached table for over current setting...see page 55.

Linear Actuator

7-2. HIWIN 2-Axis Controller (2)

LAK2BN



0 No Battery box

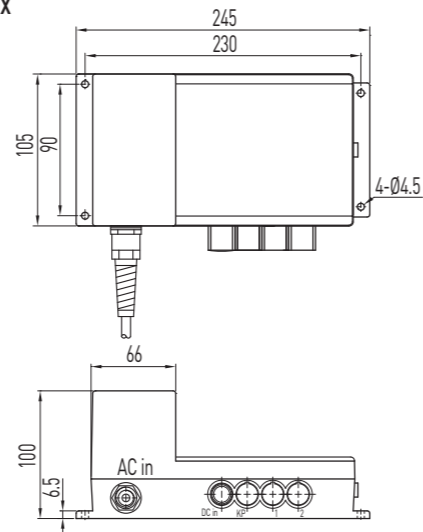

1 For 1.3Ah Battery

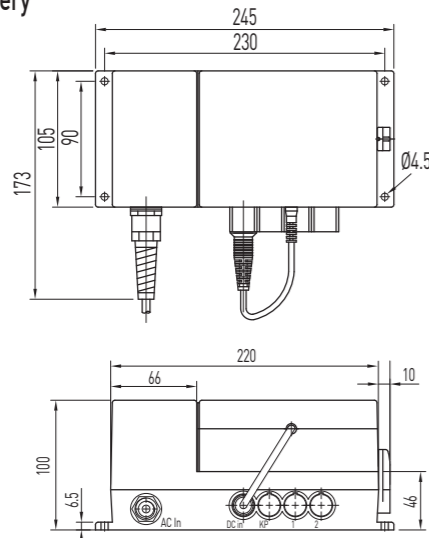

2 For 2.9Ah Battery

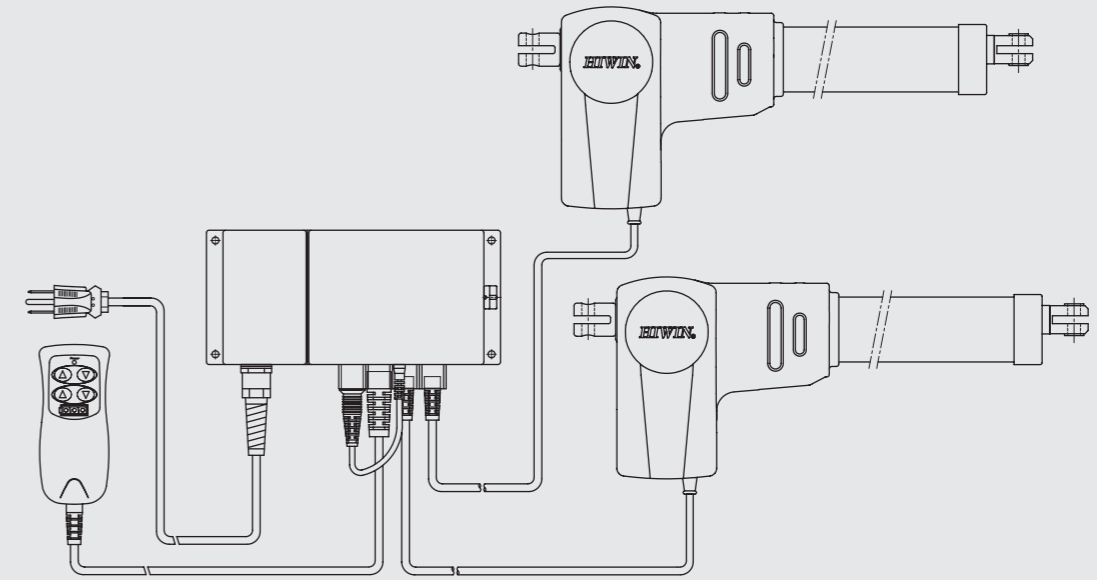
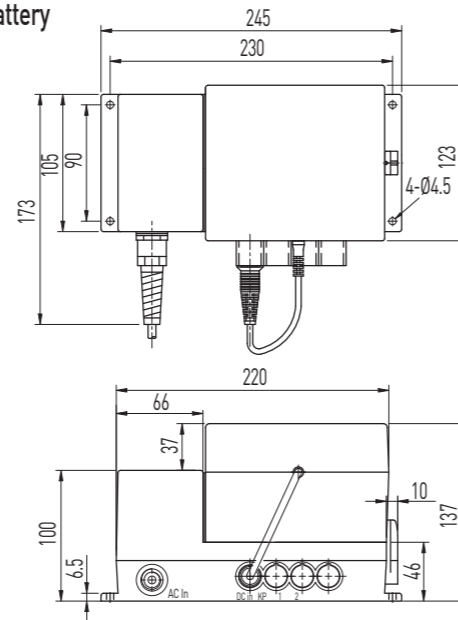

Ordering Information

LAK2BN - 1 - D0 - 110 - B E				
Battery	Actuator No. 1~2	Input Voltage	Color	Special models according to Client's requirement
0: None Battery box	0: None	100: AC100V; 110: AC110V	B: Black	None
1: 1.3Ah	A-H: Over current setting value	220: AC220V; 230: AC230V	G: Gray	E = Special requirement
2: 2.9Ah				

* Check attached table for over current setting...see page 55.

Table 7.2 Specifications

Input voltage	AC 100 / 110 / 220 / 230V(50/60Hz)
Output power	144VA (24VDC) max.
Duty cycle	10%
Protection	IP54
Working temp.	+5°C~40°C

Option:

- (1) IP66
- (2) Custom program
- (3) Two axes move simultaneously
- (4) Two axes move synchronously (Actuators must have feedback)

Features of the LAK2BN

- Control 1 or 2 Linear Actuators
- Compact size
- Over load protection
- Soft - start / stop
- Standard cable length: 4M
- Rechargeable Battery

- Low battery indicator (alarm)
- Battery capacity: 1.3Ah (12VDCx2) (Option: 2.9Ah, 12VDCx2)
- *Note: Please charge battery for at least 8 hours before initial use.

Current vs. Durable Period under Load (1.3Ah)

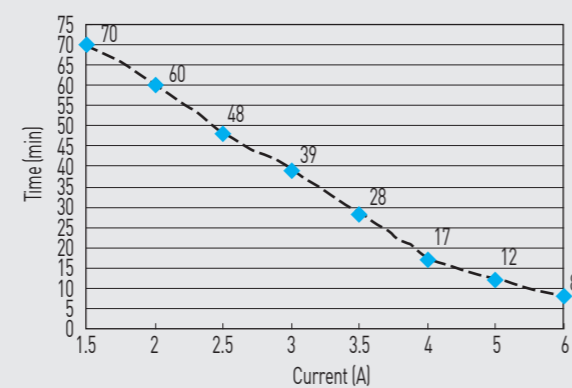

Note: 1.The test results are obtained under duty cycle 10% (2 minutes of continuous operation followed by 18 minutes of non-operation).
2.The Test results are for reference only, actual value will be different due to the battery performance.

Linear Actuator

7-3. HIWIN 2-Axis Controller (3)

LAK2D

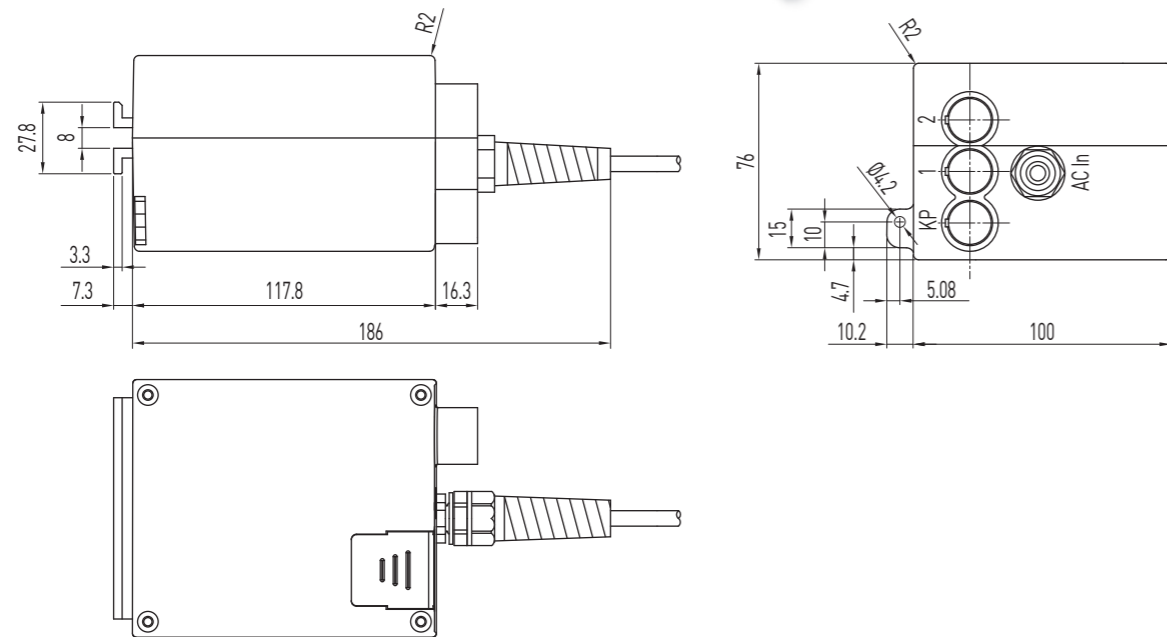

LAK2D can be mounted with LAM3 or LAN5

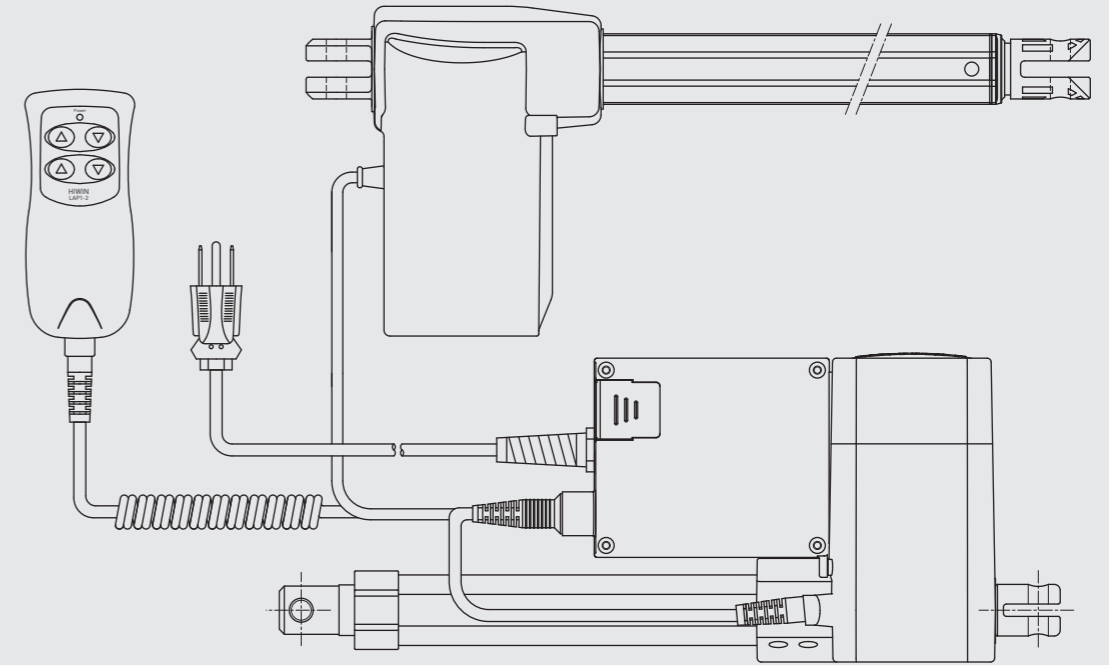

Ordering Information

LAK2D - 1 - D0 - 110 - G E				
Battery	Actuator No. 1-2	Input Voltage	Color	Special models according to Client's requirement
0: None	0: None	100: AC100V; 110: AC110V	B: Black	None
1: 9-volt alkaline battery	A-F: Over current setting value	220: AC220V; 230: AC230V	G: Gray	E = Special requirement

* Check attached table for over current setting...see page 55.
 * LAK2D over current must be set to the same value.

Table 7.3 Specifications

Input voltage	AC 100 / 110 / 220 / 230V (50 / 60Hz)
Output power	108VA (24VDC) max.
Duty cycle	10%
Protection	IP54
Working temp.	+5°C~40°C

Option:

(1) IP66

Features of the LAK2D

- Control 1 or 2 Linear Actuators
- Standard cable length: 4M
- Over load protection
- During an emergency power loss, please insert 2-9V alkaline batteries to lower the actuators. (Protection class is IP54 when LAK2D is operated with batteries)

- Can be mounted directly on the LAM3 or LAN5
- * There is no battery charge function, the 9V batteries are used for emergencies only.

Linear Actuator

7-4. HIWIN 2-Axis Controller

LAK2J

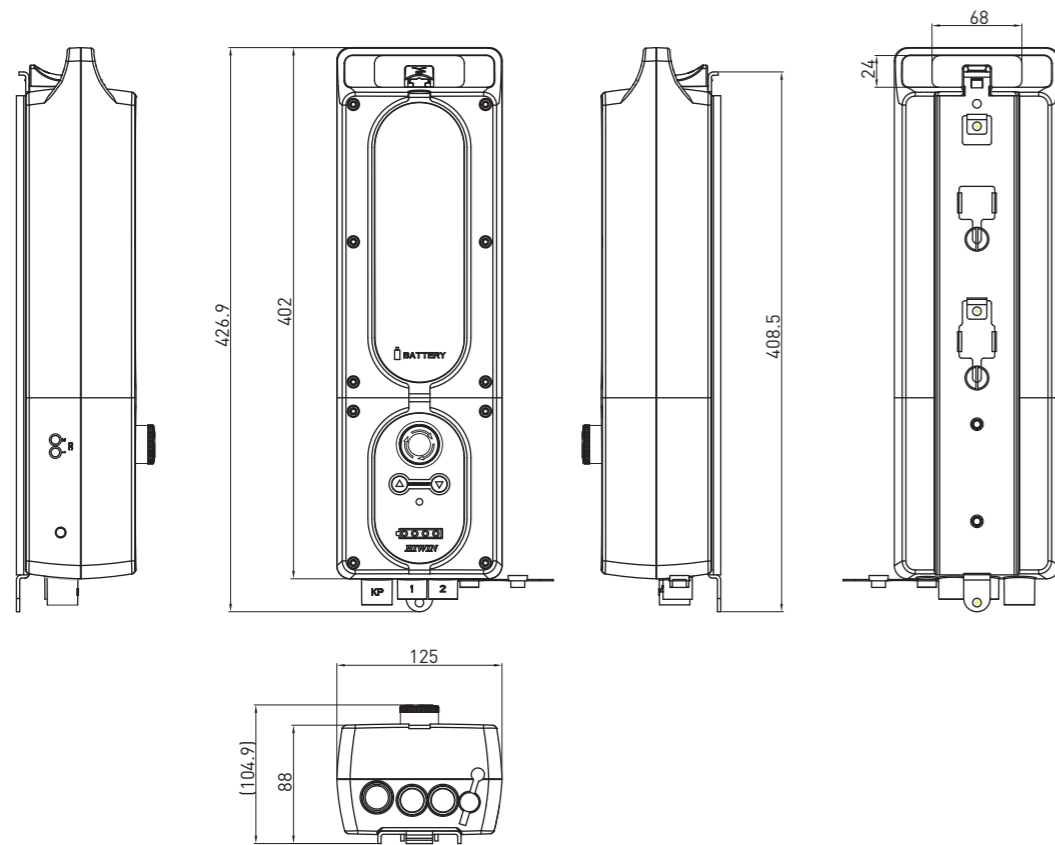

Table 7.4 Specifications

Output voltage	DC 24V
Duty cycle	10%
Protection	IP54
Working temp.	+5°C~40°C

Option:

- (1) IP65
- (2) UL Version

Features of the LAK2J

- Portable design (operated by battery)
- Control 1 to 2 Linear Actuators
- Emergency stop button
- Emergency operation through front panel (only for axis 1)
- Over load protection
- Soft - start / stop
- Battery rechargeable via LAKCH charger
- Automatic alarm when the battery is low
- Automatic Energy Saving Mode
- Battery capacity 4.5Ah (12VDC*2)
- LED for power indication

*Note: 1. Please charge the battery for at least 12 hours before the initial use.
2. Controller cannot be used when charging.

Battery Characteristics

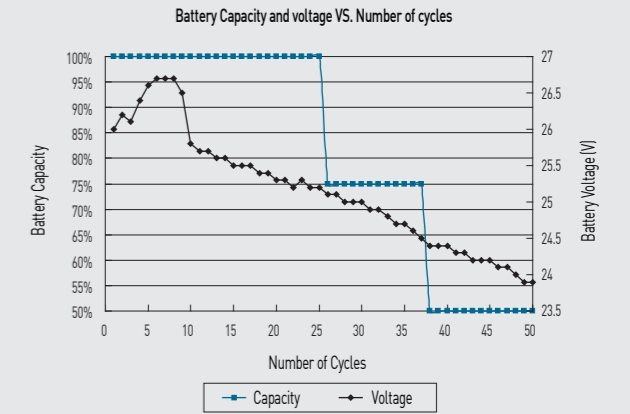

*Test results are obtained under 5A load current
Note: 1.The test results are obtained under duty cycle 10% (2 minutes of continuous operation followed by 18 minutes of non-operation).
2.The Test results are for reference only, actual value will be different due to the battery performance.

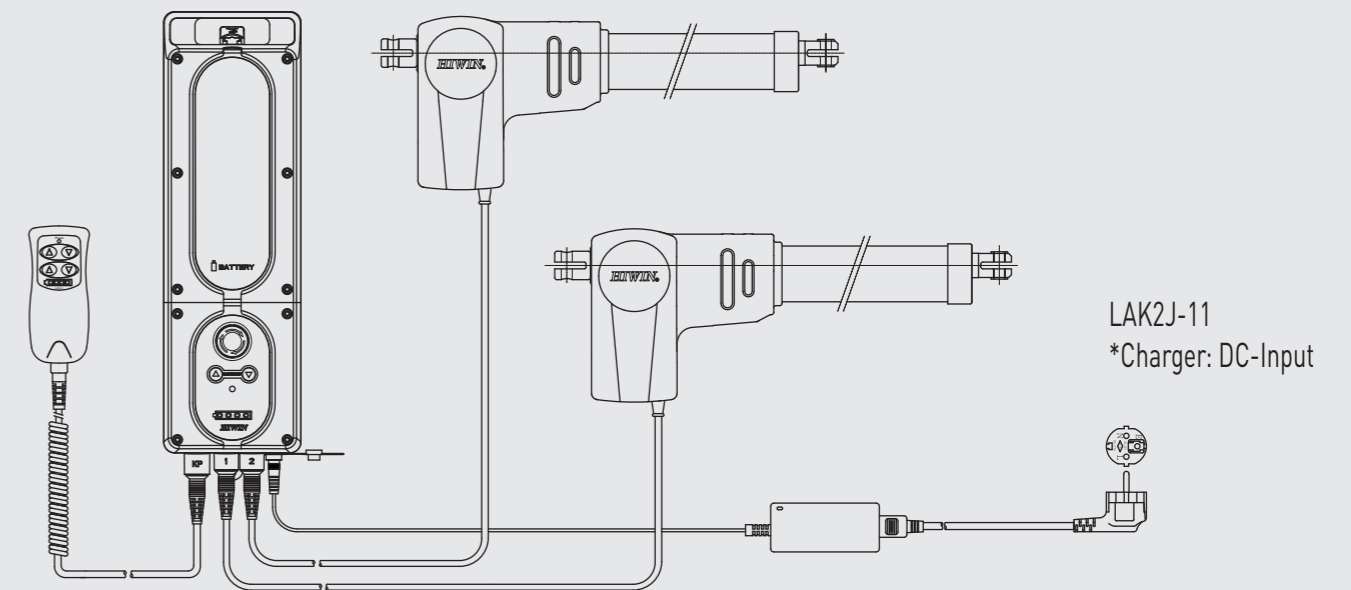

Ordering Information

LAK2J - 11 - HH - 01 - 24 - G E						
Battery	Charger	Actuator No.1~2	Software function	Output power	Color	Special models according to Client's requirement
1: 4.5Ah	1: DC in charger by LAKCH-A	0: None A-H: Over current setting value	01: Standard	DC: 24V	G: Gray	None E = Special requirement

Charger/Battery

Charger : LAKCH-A

*The illustration is for reference only, are subject to actual object

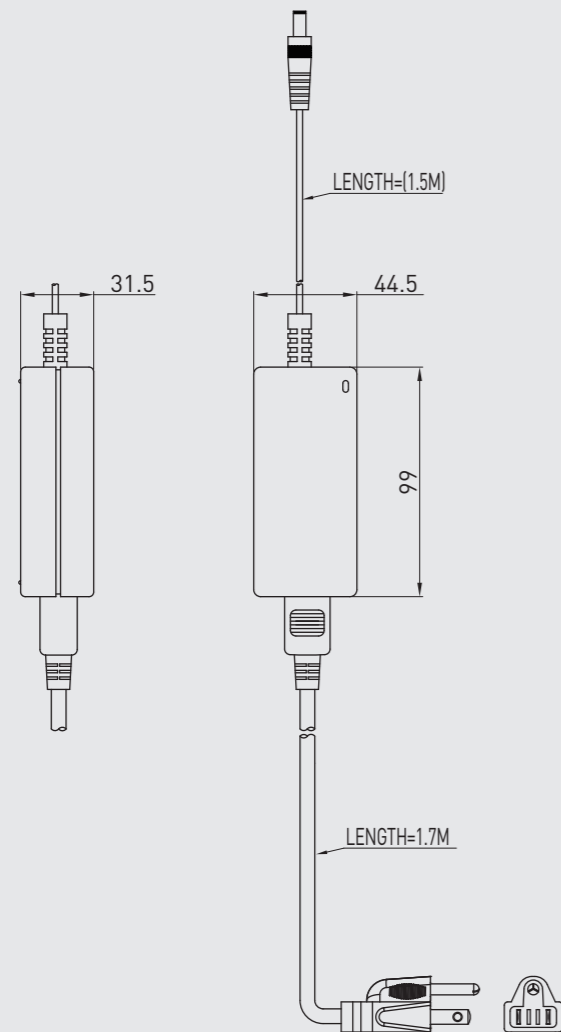

Ordering Information

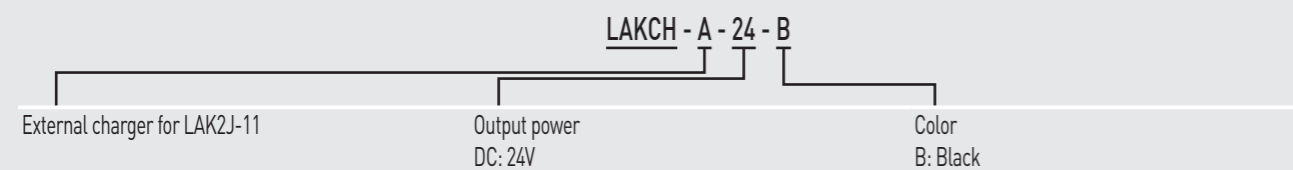

Linear Actuator

8. 4-Axis Controller

8-1. HIWIN 4-Axis Controller

LAK4D

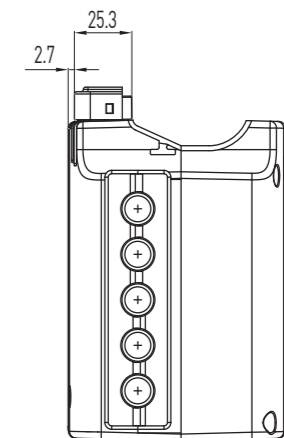
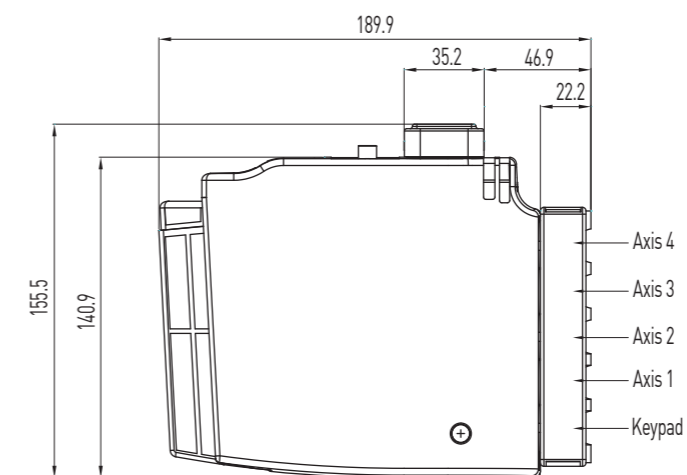
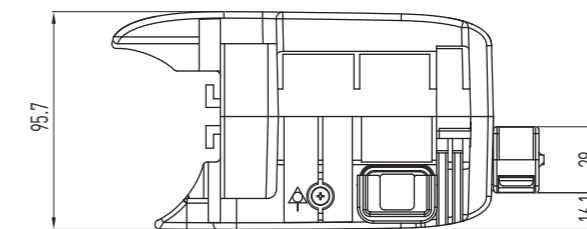

Table 8.1 Specifications

Input voltage	AC 100 / 110 / 120 / 220 / 230V (50/60Hz)
Output power	72.5VA (24VDC) max.
Duty cycle	10%
Protection	IP54
Working temp.	+5°C~40°C

Option:

- (1) IP66
- (2) Output power: 144VA, 216VA
- (3) UL Version

Features of LAK4D

- Control 1 to 4 Linear Actuator
- Standard cable length: 4M
- Detachable cable retainer (protection against accidental unplugging)
- Removable AC power cable.

- LED power display.
- Can be mounted directly on the LAN5.
(LAN5 min. RL must be greater than 300mm)
- * Notes: LAK4D without over current protection.

LAK4D can be mounted with LAN5

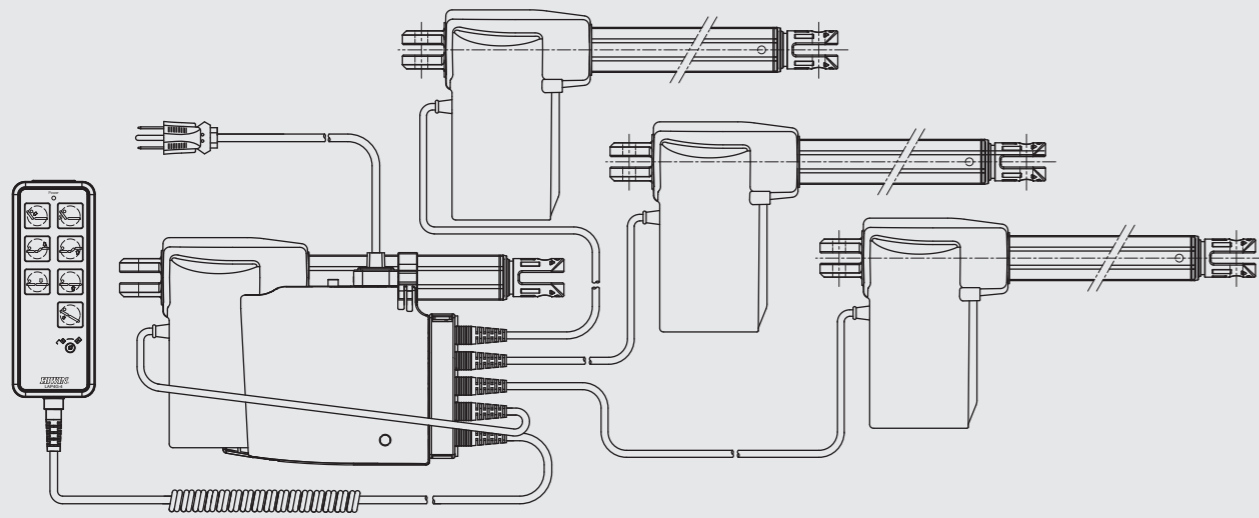

Ordering Information

LAK4D - D000 - 110 - G E			
Actuator No.1~4 0: None	Input Voltage 100: AC100V; 110: AC110V	Color B: Black	Special models according to Client's requirement None
A-H: Only indicate the actuator maximum current, not indicate over current setting value.	220: AC220V; 230: AC230V 120: AC 120V	G: Gray	E = Special requirement

Linear Actuator

9. 6-Axis Controller

9-1. HIWIN 6-Axis Controller

LAK6B

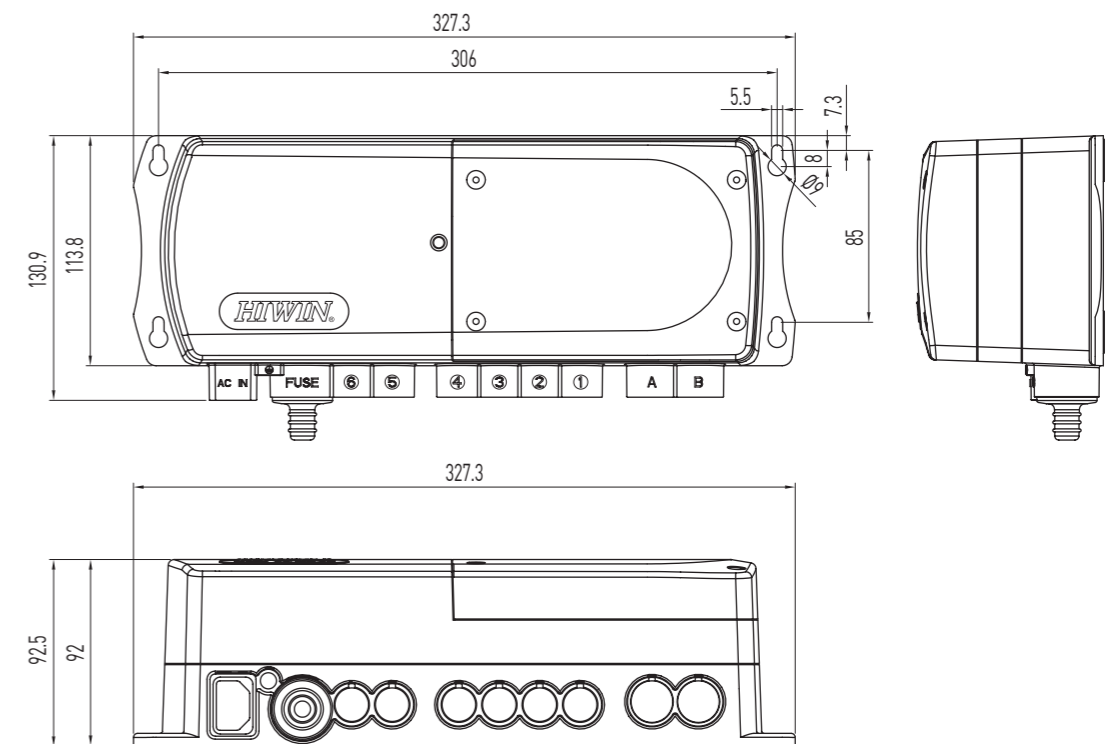

Table 9.1 Specifications

Input voltage	AC 100 / 110 / 220 / 230V (50/60Hz)
Output power	216VA (24VDC) max.
Duty cycle	10%
Protection	IP54
Working temp.	+5°C~40°C

Option:

- (1) IP66
- (2) Custom program

Features of LAK6B

- Control 1 to 6 Linear Actuators
- Over load protection
- Soft-start
- Standard cable length: 4M
- Rechargeable battery
- Low battery indicator (alarm)
- Automatic energy saving
- Battery capacity 1.3Ah (12VDCx2)

* Note: Simultaneous movement is not available for LAN3A/-2/-3(24Q)

* Note: Please charge battery for at least 8 hours before initial use.

- Main fuse replaceable by external plug
- Spare fuse inside the fuse plug
- External ground connection
- LED power indication

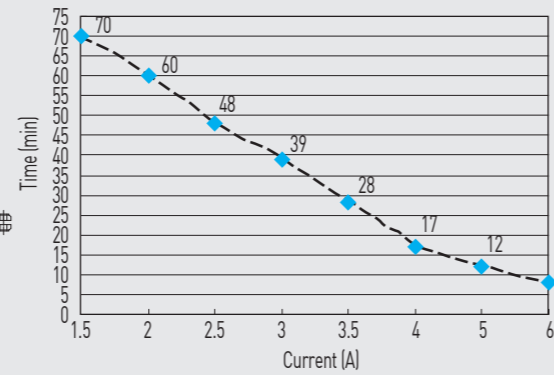
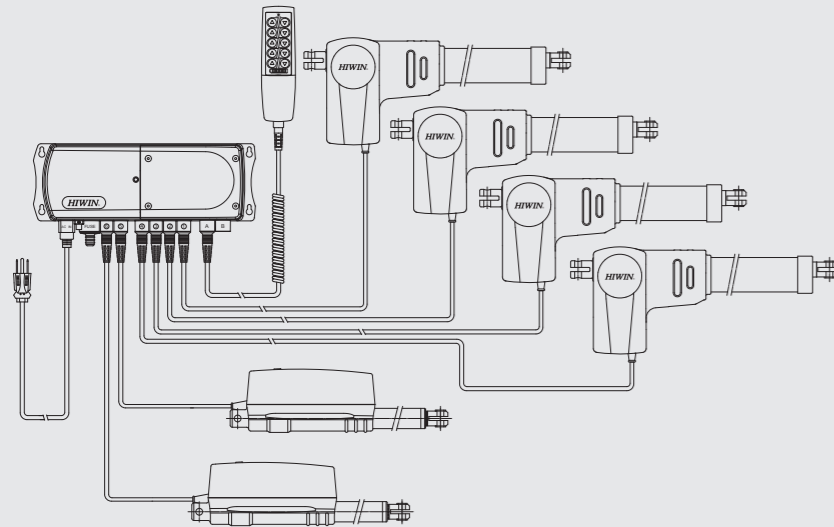

Note: 1.The test results are obtained under duty cycle 10% (2 minutes of continuous operation followed by 18 minutes of non-operation).
2.The Test results are for reference only, actual value will be different due to the battery performance.

Ordering Information

LAK6B - 1 - D 00000 - 00 - 110 - G E

Battery	Actuator No.1~6	Type	Input Voltage	Color	Special models according to Client's requirement
0: No	0: None	00: Standard	100: AC100V; 110: AC110V	B: Black	None
1: 1.3Ah	A~J: Over current setting value	01: Custom software	220: AC220V; 230: AC230V	G: Gray	E = Special requirement

* Check attached table for over current setting...see page 55.

Over Current Setting Table

Code No.	Current setting	Actuator Model	Controller Model
A	2.5A	LAS4-1	LAK2; LAK2D; LAK2LN; LAK2BN; LAK2J; LAK4D; LAK6B
B	3.0A	LAS1-1; LAS3-1	LAK2; LAK2D; LAK2LN; LAK2BN; LAK2J; LAK4D; LAK6B
C	4.0A	LAS1-2; LAS3-2; LAS4-2; LAM2-3; LAS2-1	LAK2; LAK2LN; LAK2D; LAK2BN; LAK6B; LAK2J; LAK4D
D	5.0A	LAM3-4; LAN5-2/-3/-4; LAM2-1/-2	LAK2; LAK2D; LAK2LN; LAK2BN; LAK2J; LAK4D; LAK6B
E(24V)	6.0A	LAM3-2; LAN4-3/-4; LAN5-1;LAC1	LAK2D; LAK2BN; LAK2J; LAK4D; LAK6B;LAK2;LAK2LN
E(12V)	6.0A	LAS1-1(12V); LAS3-1(12V); LAS4-1(12V); LAM2-3; LAS2-1	LAK2(DC)
F(24V)	7.0A	LAM3-1; LAN4-1/-2; LAN5-3/-4(24Q)	LAK2; LAK2D; LAK2LN; LAK2BN; LAK2J; LAK4D; LAK6B
F(12V)	7.0A	LAS1-2(12V); LAS3-2(12V); LAS4-2(12V); LAM2-3	LAK2(DC)
G(24V)	8.0A	LAM1-1/-2/-1A; LAN5-1/-2(24Q)	LAK2; LAK2LN; LAK6B; LAK2J
G(12V)	8.0A	LAM1-1/-2	LAK2(DC)
H(24V)	9.0A	LAN3A-1/-2/-3/-4(24V)	LAK6B; LAK2J
H(12V)	9.0A	LAM2-1/-2	LAK2(DC)
I	10A	For reservation	
J	12A	LAN3A-1/-2/-3/-4(24Q)	LAK6B; LAK2J
K	14A	For reservation	
L	15A	LAN1-1/-2/-3(12V); LAM1-1/-2/-1A(12V); LAM3(12V); LAN4(12V)	LAK2(DC)
Z	**A	Special current value (special requirement)	

LA Cable Connector Vs. Controller Model

Actuator Model	Normal connector	Controller Model	
		LAK2 / LAK2J / LAK2LN	LAK2BN / LAK2D / LAK4D / LAK6B
LAM1	bare wire		
LAM2	bare wire		
LAM3	bare wire		
LAS1	bare wire		
LAS2	bare wire		
LAS3	bare wire		
LAS4	bare wire		
LAN1	bare wire		
LAN3A	bare wire		
LAN4	bare wire		
LAN5	bare wire		
LAC1	bare wire		

Linear Actuator

10. Battery

10-1. HIWIN Battery

LAKB

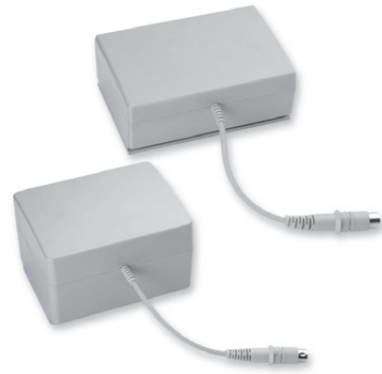

Battery: LAKB-1

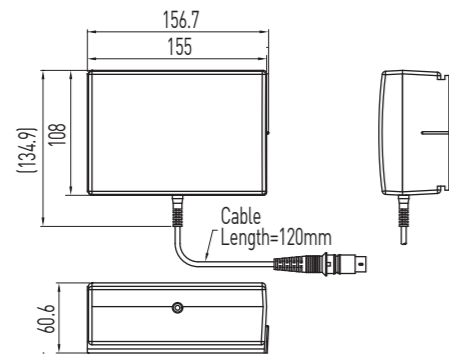

Battery: LAKB-3

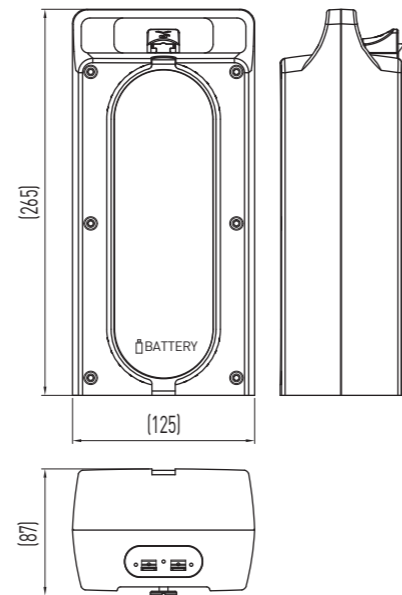

Battery: LAKB-2

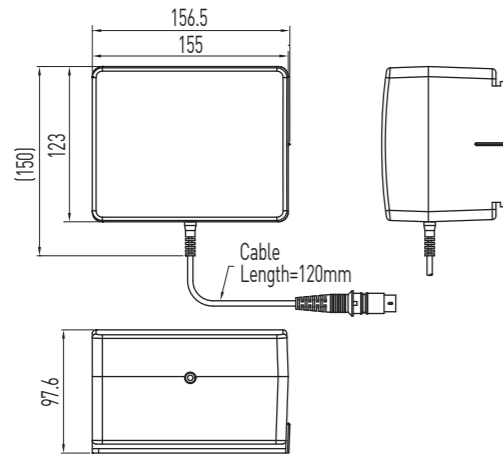

Ordering Information

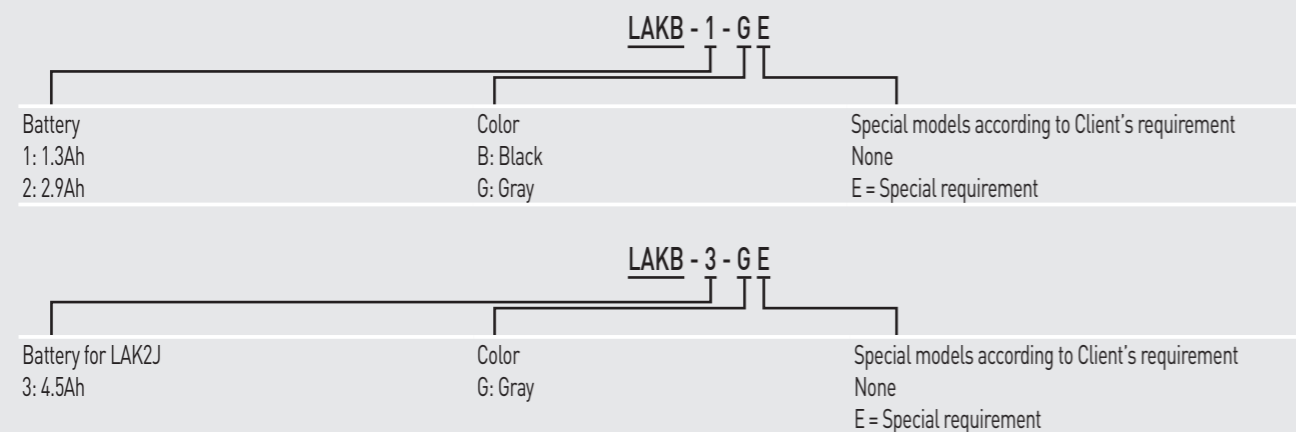

Linear Actuator

11. Over Current Protection Box

11-1. HIWIN Over Current Protection Box

LAKC1-1

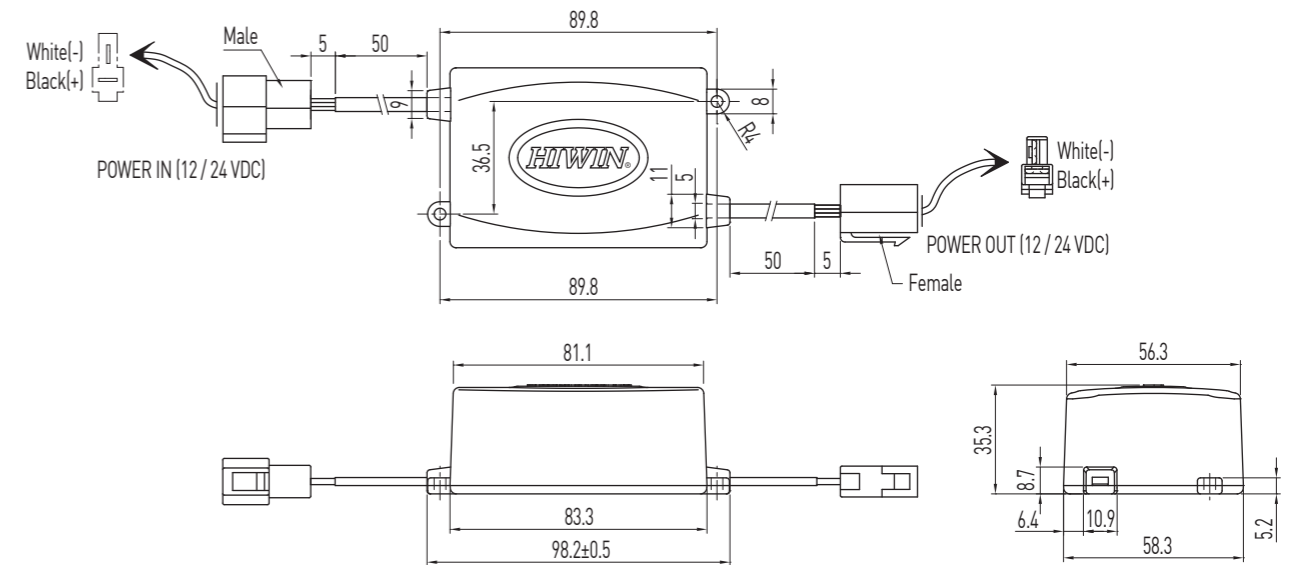

Table 11.1 Specifications

Input voltage	12/24VDC
Output power	12/24VDC
Duty cycle	10%
Protection	IP54
Working temp.	+5°C~40°C

Option:

(1) IP66

Features of LAKC1-1

- Compact size
- Low cost
- Easy to use
- Multiple over-current settings available
- Fast response time

For Series

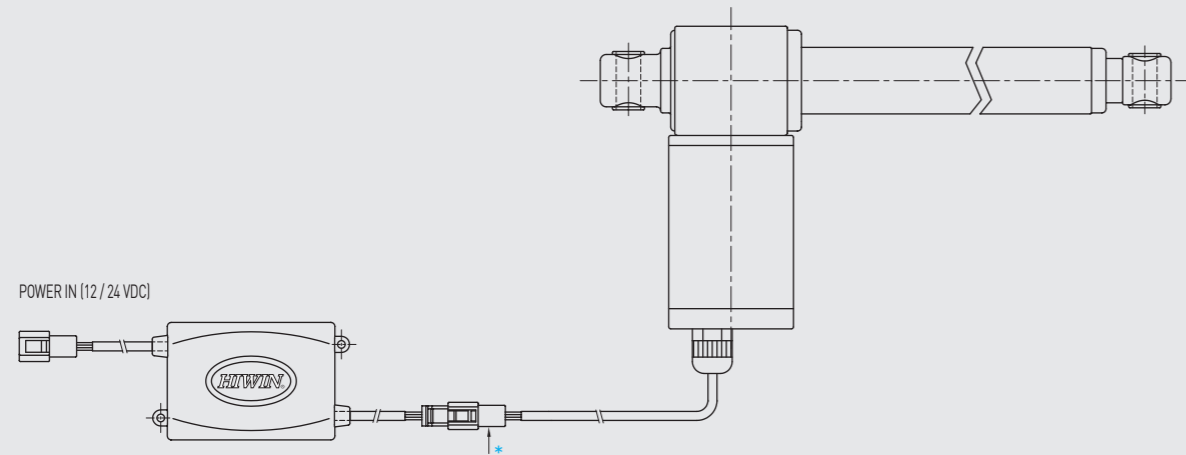

* When purchasing an actuator to be connected with the LAKC1, please inform the Hiwin sales representative.

Ordering Information

Model number	Input (Output) Voltage	Over Current Setting	Color	Special models according to Client's requirement
	12: 12VDC 24: 24VDC	12V: 2: 2A 3: 3A 4: 4A 5: 5A 6: 6A 8: 8A 10: 10A 12: 12A 18: 18A	24V: 2: 2A 2.5: 2.5A 3: 3A 4: 4A 5: 5A 6: 6A 7: 7A 8: 8A 9: 9A 10: 10A	B : Black G: Gray

LAKC1 - 1 - 12 - 6 G E

E=Ignore this part of the serial number if not available

Linear Actuator

12. Keypad Series

12-1. HIWIN Keypad Series

LAP1

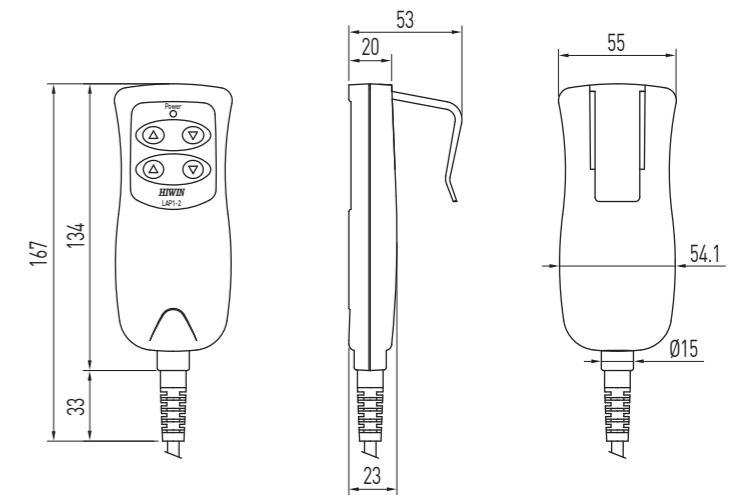

Features of the LAP1

- Controls a maximum of 2 Actuators
- Compatible with the LAK2, LAK4D, LAK2LN, LAK2D, & the LAK6B
- Ergonomic design
- Standard cable length: coil 600mm; total 1100mm
- Protection: IP66

LAP2

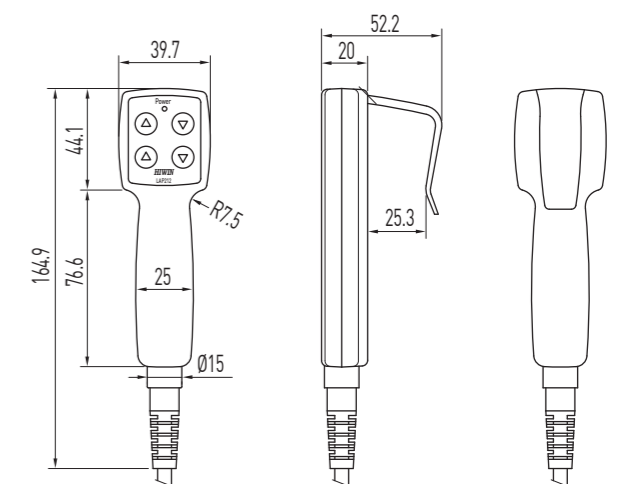

Features of the LAP2

- Control maximum of 2 Actuators
- Compatible with LAK2, LAK2D
- Ergonomic design and small size
- Standard cable length: coil 600mm; total 1100mm
- Protection: IP66

LAP3

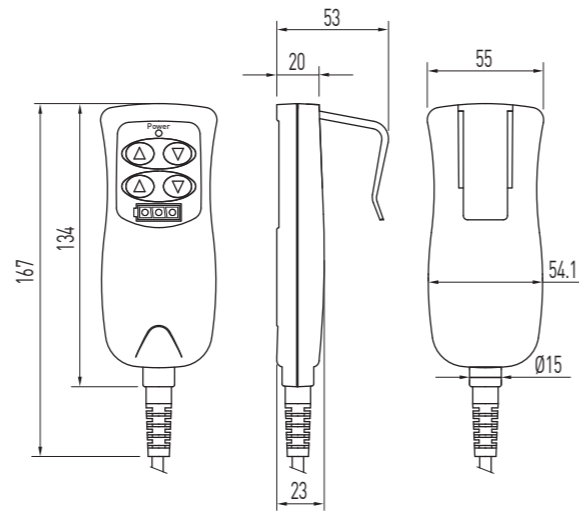

Features of the LAP3

- Control maximum of 2 Actuators
- Compatible with LAK2J
- Ergonomic design
- Standard cable length: coil 600mm; total 1100mm
- LED for battery capacity
- Protection: IP66

LAP4G

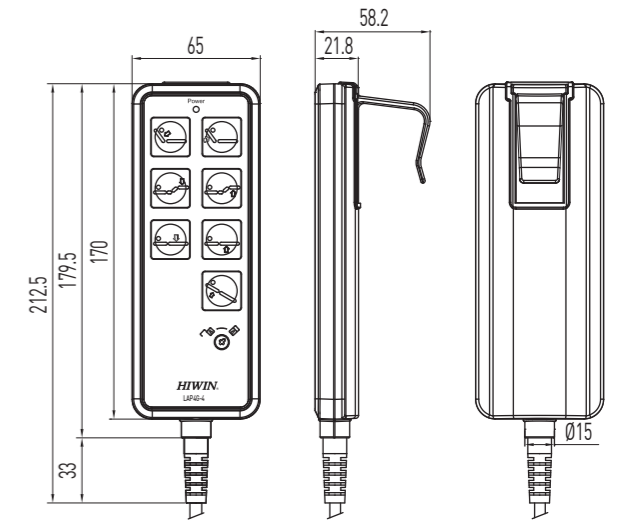

Features of the LAP4G

- Control maximum of 6 Actuators
- Compatible with LAK4D, LAK6B
- Ergonomic design
- Standard cable length: coil 600mm; total 1100mm
- Protection: IP66
- With lock function

Option:

- (1) UL version
- (2) Cable length: coil 600mm; total 2250mm

LAP3N

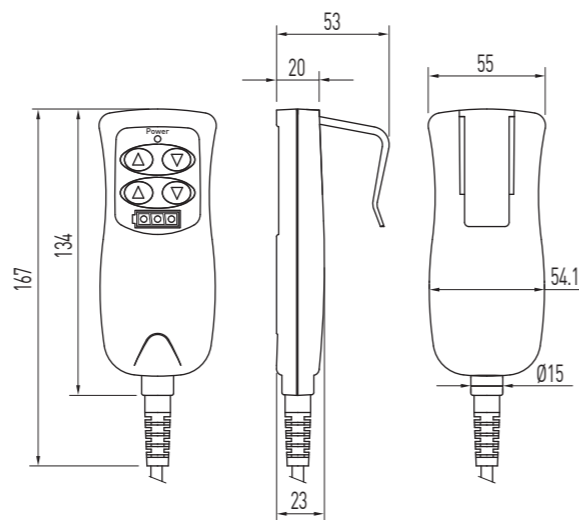

Features of the LAP3N

- Control maximum of 2 Actuators
- Compatible with LAK2BN
- Ergonomic design
- Standard cable length: coil 600mm; total 1100mm
- LED for battery capacity
- Protection: IP66
- *Option: Cable length: coil 600mm; total 2250mm

LAP4N

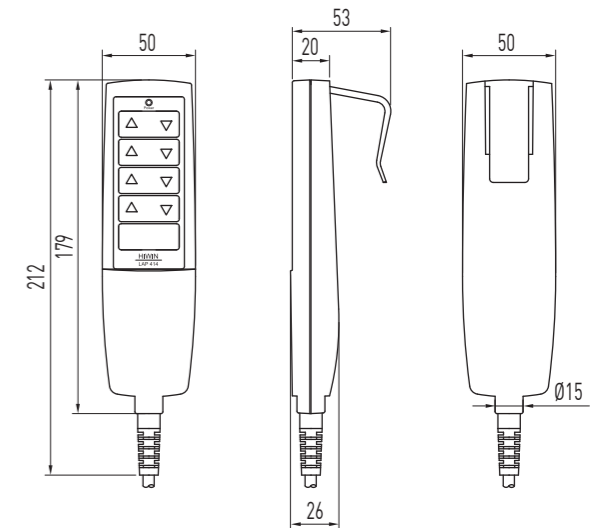

Features of the LAP4N

- Control maximum of 4 Actuators
- Compatible with LAK4D, LAK6B
- Ergonomic design
- Standard cable length: coil 600mm; total 1100mm
- Protection: IP66
- * Option: Cable length: Coil 600mm; total 2250mm

LAP4R

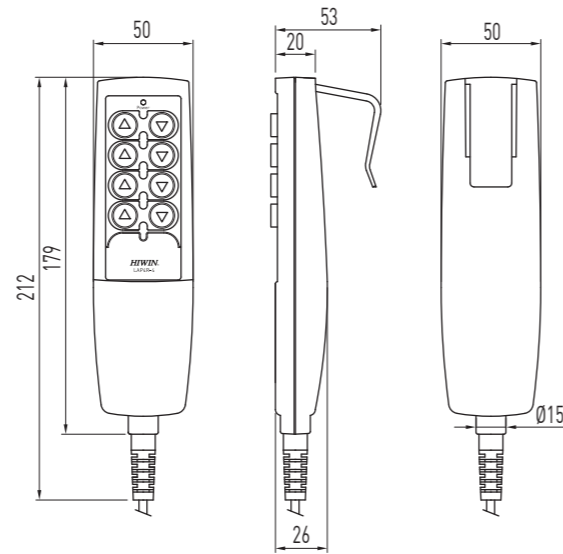

Features of the LAP4R

- Control maximum of 4 Actuators
- Compatible with LAK4D, LAK2J, LAK6B
- Ergonomic design

- Standard cable length: coil 600mm; total 1100mm
- Protection: IP66
- * Option: Cable length: coil 600mm; total 2250mm

LAP4M

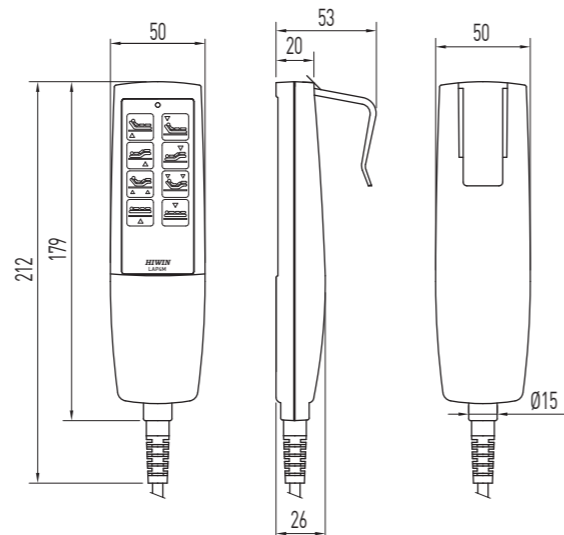

Features of the LAP4M

- Control maximum of 4 Actuators
- Compatible with LAK4D

- Ergonomic design
- Standard cable length: coil 600mm; total 1100mm

- Protection: IP66
- * Option: Cable length: coil 600mm; total 2250mm

LAP5

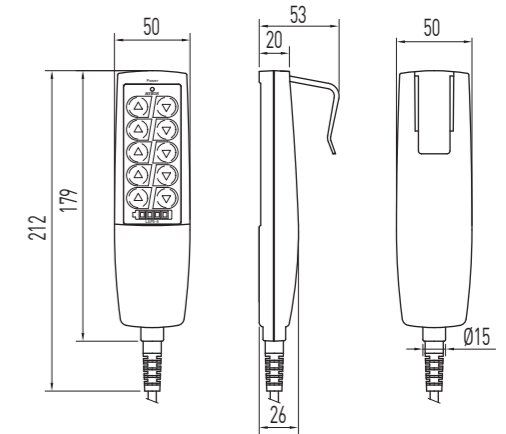

Features of the LAP5

- Control maximum of 5 Actuators
- Compatible with LAK6B, LAK2J

- Ergonomic design
- Standard cable length: coil 600mm; total 1100mm

- Protection: IP66

Ordering Information

Model number	Number of axis controlled	Color	Special models according to Client's requirement
LAP1	LAP1 - 2 - B E	B: Black	None
LAP2		G: Gray	E=Ignore this part of the serial number if not available
LAP3			
LAP3N			
LAP4N			
LAP4G			
LAP4M			
LAP4R			
LAP5			

LAFS1

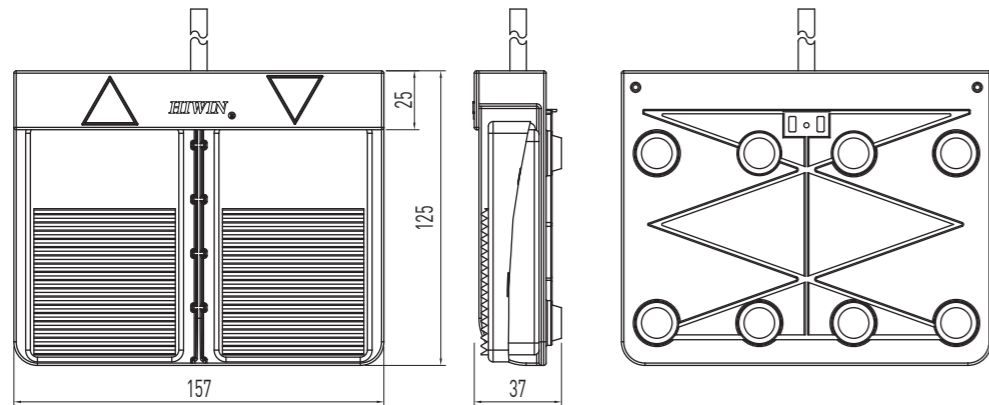

Features of the LAFS1

- Controls 1 Actuator
- Compatible with all controllers
- * Notice the type of controller

- Easily portable with attached magnet
- Standard cable length: coil 600mm; total 1100mm

Ordering Information

Model number	Number of axis controlled	Color	Special models according to Client's requirement
LAFS1	1	G: Gray	None E = Ignore this part of the serial number if not available

LAFS1 - 1 - G E

Linear Actuator

13.Options for each type

13-1. Standard Cable length of the actuator

Item	Type	Standard cable length(Straight line)			Cable diagram
		1M	1.5M	2M	
1	LAM1				<p>(Bare Wire-Standard)</p>
2	LAM2				
3	LAM3				
4	LAS1				<p>(DIN 4 PIN Connector)</p>
5	LAS2				
6	LAS3				
7	LAS4				
8	LAN1				<p>(Audio Connector)</p>
9	LAN3A				
10	LAN4				
11	LAN5				
12	LAC1				
13	LAN5 Coil				

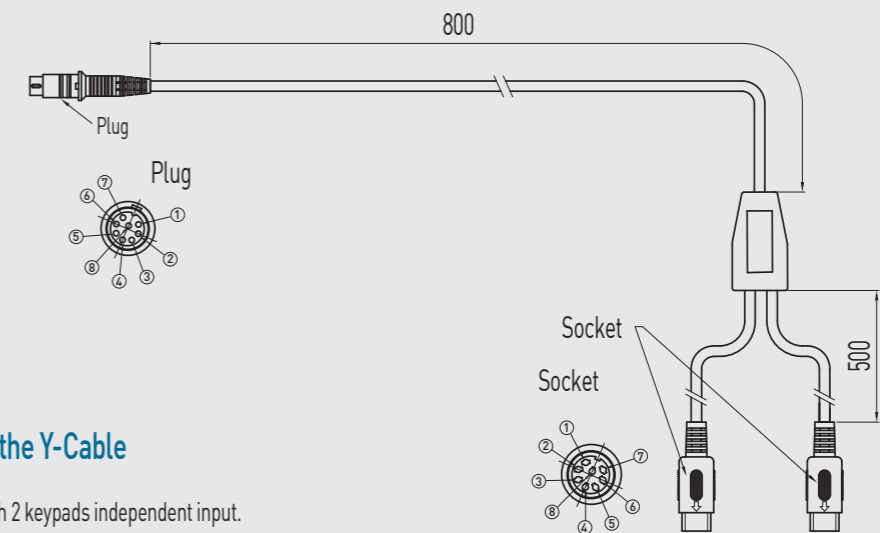

Features of the Y-Cable

- Compatible with 2 keypads independent input.

LAPY - 2 - B E

Model of Y extension cable	Cable	Color	Special models according to Client's requirement
LAPY - 2 - B E	2: Straight cable	B: Black	None E = Ignore this part of the serial number if not available

13-2. HIWIN Options for each Actuator Type

Series	Function	IP54	IP65	IP66	Back fixture turn 90°	Rod end with flat connector	Safety nut	Spline (push only)	Quick release	Internal limit switches	External limit switches	Hall Sensor			Potentiometer	MR Sensor
												NPN	PNP	TTL		NPN
LAM1	LAM1-1	●	▲		▲						▲					
	LAM1-2	●	▲		▲						▲					
	LAM1-1A	●	▲		▲						▲					
LAM2	LAM2-1	●		▲	▲	●				●	▲					▲
	LAM2-2	●		▲	▲	●				●	▲					▲
	LAM2-3	●		▲	▲	●				●	▲					▲
LAM3	LAM3-1	●		▲	▲		▲			●						
	LAM3-2	●		▲	▲		▲			●						
	LAM3-4	●		▲	▲		▲			●						
LAS1	LAS1-1	●		▲	▲	▲				●	▲					
	LAS1-2	●		▲	▲	▲				●	▲					
LAS2	LAS2-1	●		▲	▲	▲				●	▲	■	■	■	■	
LAS3	LAS3-1	●		▲	▲	▲				●	▲	■	■	■	■	
	LAS3-2	●		▲	▲	▲				●	▲	■	■	■	■	
LAS4	LAS4-1	●	▲							●		▲		▲		
	LAS4-2	●	▲							●		▲		▲		
LAN1	LAN1-1	●		▲	▲		▲	▲		●		▲		▲		
	LAN1-2	●		▲	▲		▲	▲		●		▲		▲		
	LAN1-3	●		▲	▲		▲	▲		●		▲		▲		
LAN3A	LAN3A-1	●		▲	▲		▲	▲	▲	●	▲			▲		▲
	LAN3A-2	●		▲	▲		▲	▲	▲	●	▲			▲		▲
	LAN3A-3	●		▲	▲		▲	▲	▲	●	▲			▲		▲
	LAN3A-4	●		▲	▲		▲	▲	▲	●	▲			▲		▲
LAN4	LAN4-1	●		▲			▲	▲								
	LAN4-2	●		▲			▲	▲								
	LAN4-3	●		▲			▲	▲								
	LAN4-4	●		▲			▲	▲								
LAN5	LAN5-1	●	◆	■	▲		▲	▲	▲	●		▲		▲		
	LAN5-2	●	◆	■	▲		▲	▲	▲	●		▲		▲		
	LAN5-3	●	◆	■	▲		▲	▲	▲	●		▲		▲		
	LAN5-4	●	◆	■	▲		▲	▲	▲	●		▲		▲		
LAC1	LAC1-1	●								●		■		■		■

"●" Standard
 "▲" Option is available.
 "◆" "■" Only 1 option is available.

13-3. HIWIN Option for each Controller Type

Type		LAK2LN	LAK2	LAK2BN	LAK2D	LAK2J	LAK4D	LAK6B
Function								
IP54		●	●	●	●	●	●	●
IP65								
IP66		▲	▲	▲	▲		▲	▲
Input Voltage	DC 12V		■					
	DC 24V		■			●		
	AC 100V	■	■	■	■		■	■
	AC 110V	■	■	■	■		■	■
	AC 120V	■	■	■	■		■	■
	AC 220V	■	■	■	■		■	■
	AC 230V	■	■	■	■		■	■
Output Power (24V)	72.5VA						●	■
	108VA	●	●		●			
	144VA						■	■
	216VA						■	●
Max. control axis no.	1	2	2	2	2	4	6	
Over load protection	●	●	●	●				●
Relay protection		●	●	●	●			●
Battery	9V alkaline				▲			
	1.3Ah (Lead Acid)			■				●
	2.9Ah (Lead Acid)			■				
	4.5Ah (Lead Acid)					●		
Charge function			●		▲		●	
Energy saving			●		●		●	
Custom program			▲		▲		▲	
Control external limit switch	●							▲
Mounted with actuator				●			●	
Detachable cable retainer							●	
Removable AC power cable							●	●

"●" Standard
 "▲" Option is available.
 "◆" "■" Only 1 option is available.

Linear Actuator

13-4. HIWIN Customer Requirements (LA)

* : Required

HIWIN® MIKROSYSTEM Customer's Requirements (LA) NO : _____			
*Customer		*Application	<input type="checkbox"/> Medical <input type="checkbox"/> Aviation <input type="checkbox"/> Automobile <input type="checkbox"/> other_____
Tel		Fax	
Contact person		Executive	
<input type="checkbox"/> Actuator		<input type="checkbox"/> Controller	
*Voltage VDC (V)		*Input voltage (V)	AC _____ V or DC _____ V
*Max. current (A)		*Control axis no	
*Max. thrust force (N)		*Battery	<input type="checkbox"/> YES <input type="checkbox"/> NO
*Max. pulling force (N)		*Power cord type	<input type="checkbox"/> US <input type="checkbox"/> UK <input type="checkbox"/> EU other_____
*Max. holding force (N)		*Over load protection	<input type="checkbox"/> YES <input type="checkbox"/> NO
*Stroke (mm)		*IP Class	
*Install length (mm)		Output power (VA)	
*Speed (mm/s)	No load	Power cord length	
	Full load	Removable Power cord	<input type="checkbox"/> YES <input type="checkbox"/> NO
*Load (N)		Duty cycle	
*IP Class		Operation temp (°C)	
No-Load current (A)		Outdoor use	<input type="checkbox"/> YES <input type="checkbox"/> NO
Duty cycle		With HIWIN's Actuator	<input type="checkbox"/> YES (Model) _____ <input type="checkbox"/> NO
Operation temp (°C)		Custom program	<input type="checkbox"/> YES <input type="checkbox"/> NO
Outdoor use	<input type="checkbox"/> YES <input type="checkbox"/> NO	Housing color	<input type="checkbox"/> BLACK <input type="checkbox"/> GRAY
Direction		Expected price	
Bending moment	<input type="checkbox"/> YES <input type="checkbox"/> NO	Quantity (year/month)	
With HIWIN's L/S	<input type="checkbox"/> YES <input type="checkbox"/> NO	<input type="checkbox"/> Keypad	
With HIWIN's Controller	<input type="checkbox"/> YES (Model) _____ <input type="checkbox"/> NO	*Control axis no	
With customer's L/S	<input type="checkbox"/> YES <input type="checkbox"/> NO	*Custom mask	<input type="checkbox"/> YES <input type="checkbox"/> NO
Over current	<input type="checkbox"/> YES <input type="checkbox"/> NO	*Lock function	<input type="checkbox"/> YES <input type="checkbox"/> NO
Position feedback	<input type="checkbox"/> YES <input type="checkbox"/> NO	*With HIWIN's Controller	<input type="checkbox"/> YES (Model) _____ <input type="checkbox"/> NO
Special install equirement (Fixture,Space...etc.)		Housing color	<input type="checkbox"/> BLACK <input type="checkbox"/> GRAY
Expected price		Key mode	<input type="checkbox"/> Membrane <input type="checkbox"/> Rubber
Quantity (year/month)		Expected price	
		Quantity (year/month)	
*Other function / requirement :			
[The following fills in by HIWIN Engineer] Recommend Specification :			
Engineer :		Manager :	

FME0014-05

Linear Actuator Technical Information

Publication Date : October 1999, first edition

Print Date : October 2021, 28th edition

1. HIWIN is the registered trademark of HIWIN Group. For your protection, avoid buying counterfeit products from unknown sources.
 2. Actual products may differ from specifications and photos provided in this catalog. These differences may be the result of various factors including product improvements.
 3. HIWIN will not sell or export products or processes restricted under the "Foreign Trade Act" or related regulations. Export of restricted products should be approved by proper authorities in accordance with relevant laws and shall not be used to manufacture or develop nuclear, biochemical, missiles or other weapons.
-



Global Sales and Customer Service Site

HIWIN GmbH

OFFENBURG, GERMANY
www.hiwin.de
www.hiwin.eu
info@hiwin.de

HIWIN Schweiz GmbH

JONA, SWITZERLAND
www.hiwin.ch
info@hiwin.ch

HIWIN KOREA

SUWON • CHANGWON, KOREA
www.hiwin.kr
info@hiwin.kr

HIWIN JAPAN

KOBE • NAGOYA • TOKYO • TOHOKU •
NAGANO • SHIZUOKA • HOKURIKU •
HIROSHIMA • FUKUOKA • KUMAMOTO,
JAPAN
www.hiwin.co.jp
info@hiwin.co.jp

HIWIN s.r.o.

BRNO, CZECH REPUBLIC
www.hiwin.cz
info@hiwin.cz

HIWIN CHINA

SUZHOU, CHINA
www.hiwin.cn
info@hiwin.cn

HIWIN USA

CHICAGO, U.S.A.
www.hiwin.us
info@hiwin.com

HIWIN FRANCE

STRASBOURG, FRANCE
www.hiwin.fr
info@hiwin.de

Mega-Fabs Motion Systems, Ltd.

HAIFA, ISRAEL
www.mega-fabs.com
info@mega-fabs.com

HIWIN Srl

BRUGHERIO, ITALY
www.hiwin.it
info@hiwin.it

HIWIN SINGAPORE

SINGAPORE
www.hiwin.sg
info@hiwin.sg

HIWIN MIKROSYSTEM CORP.

No.6, Jingke Central Rd.,
Taichung Precision Machinery Park,
Taichung 40852, Taiwan
Tel: +886-4-23550110
Fax: +886-4-23550123
www.hiwinmikro.tw
business@hiwinmikro.tw