



Linear Motor System

User Manual

Original Instructions

www.hiwinmikro.tw

Contents

CONTENTS	1		
1. GENERAL INFORMATION	1	5. ASSEMBLY AND CONNECTION	14
1.1 ABOUT THIS USER MANUAL.....	1	5.1 ASSEMBLING THE LINEAR MOTOR SYSTEM.....	15
1.2 DEPICTIONS USED IN THIS USER MANUAL	1	5.2 ASSEMBLING THE MOVED LOAD	16
1.3 MANUFACTURER'S DETAILS	3	5.3 AIR SUPPLY CONNECTION.....	16
1.4 COPYRIGHT	3	5.4 ELECTRICAL CONNECTION.....	16
1.5 PRODUCT MONITORING.....	3	6. COMMISSIONING	19
2. BASIC SAFETY NOTICES	4	6.1 SWITCH ON THE LINEAR MOTOR SYSTEM	19
2.1 INTENDED USE	4	6.2 PROGRAMMING	20
2.2 REASONABLY FORESEEABLE MISUSE	4	7. MAINTENANCE AND CLEANING	21
2.3 CONVERSIONS AND MODIFICATIONS.....	4	7.1 LINEAR MOTOR.....	23
2.4 RESIDUAL RISKS.....	5	7.2 POSITIONING MEASUREMENT SYSTEM.....	23
2.5 PERSONNEL REQUIREMENTS.....	5	7.3 ELECTROMECHANICAL COMPONENTS.....	23
2.6 PROTECTIVE EQUIPMENT	5	7.4 LINEAR GUIDEWAYS	23
2.7 LABELS ON LINEAR MOTOR SYSTEM	6	7.5 AIR BEARING SYSTEM	24
3. DESCRIPTION OF THE LINEAR MOTOR SYSTEM	7	8. TROUBLESHOOTING	25
3.1 FIELD OF APPLICATION	7	9. DISPOSAL	26
3.2 MAIN COMPONENTS OF THE LINEAR MOTOR SYSTEM	7	10. DECLARATION OF INCORPORATION	27
3.3 FUNCTIONAL DESCRIPTION.....	8		
4. TRANSPORT AND INSTALLATION	10		
4.1 DELIVERY	10		
4.2 TRANSPORT TO THE INSTALLATION SITE	10		
4.3 REQUIREMENTS AT THE INSTALLATION SITE	12		
4.4 STORAGE.....	12		
4.5 UNPACKING AND INSTALLING	13		

1. General information

1.1 About this user manual

1.1.1 Version management

Table 1.1 Version management

Version	Date	Comment
01-1	June 2017	Add the information of air bearing
01-0	March 2017	Initial creation of user manual

1.1.2 Requirements

We assume that

- operating staff are trained in the safe operation practices for linear motor systems and have read and understood this user manual in full;
- maintenance staff maintain and repair the linear motor systems in such a way that they pose no danger to people, property or the environment.

1.1.3 Availability

This user manual must remain constantly available to all persons who work with or on the linear motor systems.

1.2 Depictions used in this user manual

1.2.1 Instructions

Instructions are indicated by triangular bullet points in the order in which they are to be carried out.

Example:

- ▶ Position the linear motor system on the mounting holes.
- ▶ Place the mounting bolts into the mounting holes and tighten in a spiral pattern to a torque of 10 Nm.

1.2.2 Lists

Lists are indicated by bullet points.

Example:

The linear motor systems must not be operated:

- Outdoors
- In potentially explosive atmospheres

1.2.3 Information

Information is to describe general information and recommendations.

Example:

NOTE Please contact HIWIN for special requests.

1.2.4 Depiction of safety notices







Safety notices are always indicated using a signal word and sometimes also a symbol for the specific risk (See section 1.2.4).





The following signal words and risk levels are used:

 DANGER!
Imminent danger! Non-compliance with the safety notices will result in serious injury or death!
 WARNING!
Potentially dangerous situation! Non-compliance with the safety notices runs the risk of serious injury or death!
ATTENTION!
Potentially dangerous situation! Non-compliance with the safety notices runs the risk of damage to property or environmental pollution!

1.2.5 Symbols used

The following symbols are used in this user manual and on the linear motor system:

	No access for people with active implanted cardiac devices.		Substance hazardous to the environment!
	Warning!		Warning of crushing of hands!
	Warning of electricity!		Warning of hot surface!
	Warning of magnetic field!		

	Wear head protection!		Refer to user manual!
	Wear protective gloves!		Disconnect before carrying out maintenance or repair.
	Wear safety footwear!		Lifting point

1.3 Manufacturer's details

Table 1.4 Manufacturer's details

Address	HIWIN MIKROSYSTEM CORP. No.6, Jingke Central Rd., Taichung Precision Machinery Park, Taichung 40852, Taiwan
Tel.	+886-4-23550110
Fax	+886-4-23550123
Sales E-mail	business@hiwinmikro.tw
Customer Service E-mail	service@hiwinmikro.tw
Website	www.hiwinmikro.tw

1.4 Copyright

This user manual is protected by copyright. Any reproduction, publication in whole or in part, modification or abridgement requires the written approval of HIWIN MIKROSYSTEM.

1.5 Product monitoring

Please inform HIWIN MIKROSYSTEM, the manufacturer of the linear motor systems, of:

- Accidents
- Potential sources of danger in the linear motor systems
- Anything in this user manual which is difficult to understand

2. Basic safety notices

DANGER!



Danger from strong magnetic fields!

Strong magnetic fields around linear motor systems pose a health risk to persons with implants (e.g. cardiac pacemakers) that are affected by magnetic fields.

- ▶ Persons with implants that are affected by magnetic fields should maintain a safe distance of at least 1 m from linear motor systems.

ATTENTION!



Risk of physical damage to watches and magnetic storage media.

Strong magnetic forces may destroy watches and magnetisable data storage media near to the linear motor system!

- ▶ Do not bring watches or magnetisable data storage media into the vicinity (<300 mm) of the linear motor systems!

2.1 Intended use

The linear motor system is a linear drive and guiding system for the precise positioning of fixed mounted loads, e.g. system components within an automated system, in terms of time and location.

The LMX and LMAP linear motor systems are designed for installation and operation in horizontal positions and therefore do not feature parking brakes in their standard versions. In the case of vertical assembly, a parking brake, weight compensation device or both must be retrofitted. The loads to be moved must either be mounted on to the forcer or the base.

The linear axes can be mounted on top of one another to create multi-axis systems.

The specified linear motor systems may not be used outdoors or in hazardous areas where there is a risk of explosions. All linear motor systems may only be used for the stated intended purpose.

- The linear motor system must be operated within its specified performance limits (See Technical Information and the Approval Drawing).
- Observation of the user manual and compliance with the maintenance and repair regulations are prerequisites for the intended use of the linear motor systems.
- Any other use of the linear motor system shall be considered as contrary to the intended use.
- Use only genuine spare parts from HIWIN MIKROSYSTEM.

2.2 Reasonably foreseeable misuse

The linear motor systems must not be operated:

- Outdoors
- In potentially explosive atmospheres

2.3 Conversions and modifications

Modifications of the linear motor systems are not permitted! Please contact HIWIN MIKROSYSTEM for special request.

2.4 Residual risks

Normal operation of the linear motor systems constitutes no residual risks.

Warnings about risks that may arise during maintenance and repair work are provided in the relevant sections.

2.5 Personnel requirements

Only authorized persons may carry out work on the linear motor systems! They must be familiar with the safety equipment and regulations before starting work (See Table 2.1).

Table 2.1 **Personnel requirements**

Activity	Qualification
Normal operation	Trained personnel
Cleaning	Trained personnel
Maintenance	Trained specialist personnel of the operator or manufacturer
Repairs	Trained specialist personnel of the operator or manufacturer

2.6 Protective equipment

2.6.1 Personal protective equipment

ATTENTION!

Risk of noise.

The information below will enable the user of the machine to make a better evaluation of the hazard and risk.

- Equivalent A-weighted Sound pressure level according to EN ISO 3746: 70.5 dB (A)
- Uncertainty, K in decibels: 4.0 dB (A) according to EN ISO 4871

The emission levels are not necessarily safe working levels. Whilst there is a correlation between the emission and exposure levels, this cannot be used reliably to determine whether or not further precautions are required.

Factors that influence the actual level of exposure of the work-force include the characteristics of the work room, the other sources of noise, etc. i.e. the number of machines and other adjacent processes, and the length of time for which an operator is exposed to the noise. Also the permissible exposure level can vary from country to country.

Table 2.2 **Personal protective equipment**

Operating phase	Personal protective equipment
Normal operation	When in the vicinity of the linear motor systems, the following personal protective equipment is required: <ul style="list-style-type: none"> ● Safety shoes ● Protective helmet ● Protective gloves
Cleaning	When cleaning the linear motor systems, the following personal protective equipment is required: <ul style="list-style-type: none"> ● Safety shoes ● Protective helmet ● Protective gloves

Table 2.2 Personal protective equipment (continued)

Operating phase	Personal protective equipment
Maintenance and repairs	<p>When carrying out maintenance and repairs, the following personal protective equipment is required:</p> <ul style="list-style-type: none"> ● Safety shoes ● Protective helmet ● Protective gloves

2.6.2 Protective equipment on the linear motor system

Linear motor systems are fitted with position dampers.

- After every traverse, these position dampers must be tested at the end positions and, if necessary, replaced.
- The machine may not be operated without position dampers or when they are damaged!

2.7 Labels on linear motor system

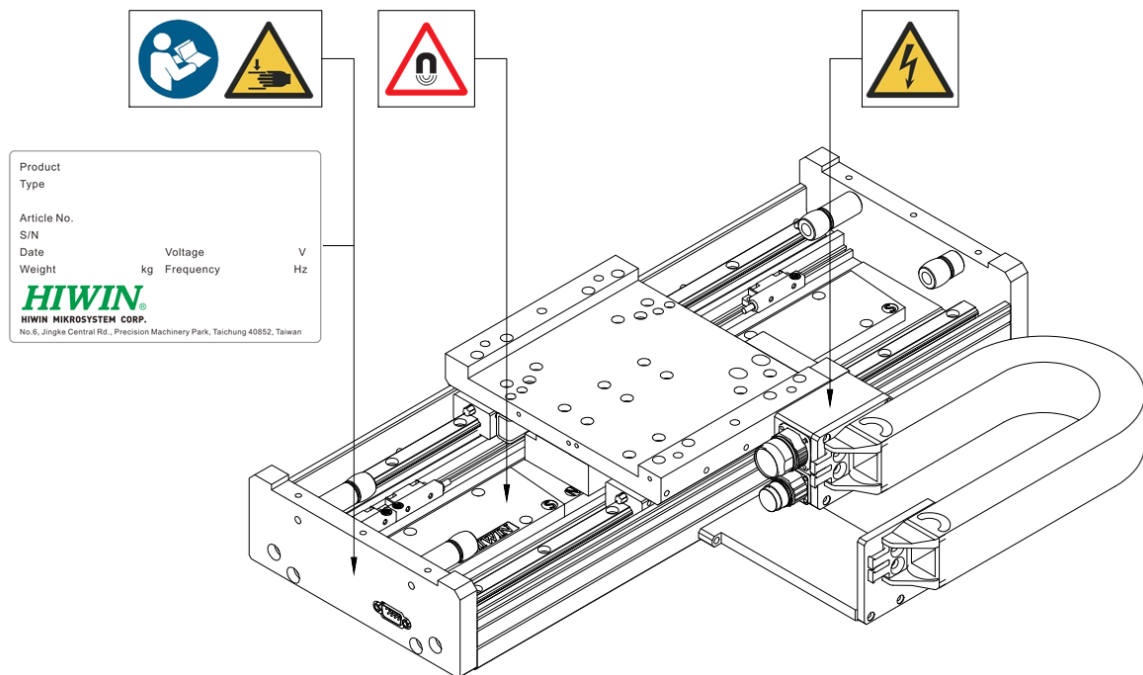

Fig 2.1 Warning symbols and type plate – here for a LMX1A linear motor system

Table 2.3 Warning symbols

Pictogram	Type and source of danger	Protective measures
	Danger from movements!	Keep out of the machine's area of movements! Prevent unauthorized access to the danger area!
	Danger of electric shock!	Disconnect the power supply of the linear motor systems before maintenance or repairs!
	Danger from strong magnetic fields!	Persons whose health may be endangered by strong magnetic fields must keep a safe distance (1 m) from the linear motor system!

3. Description of the linear motor system

3.1 Field of application

The linear motor system is used for traversing and (linear) movement of fixed mounted loads on the forcer housing. The model can be mounted and operated horizontally.

3.2 Main components of the linear motor system

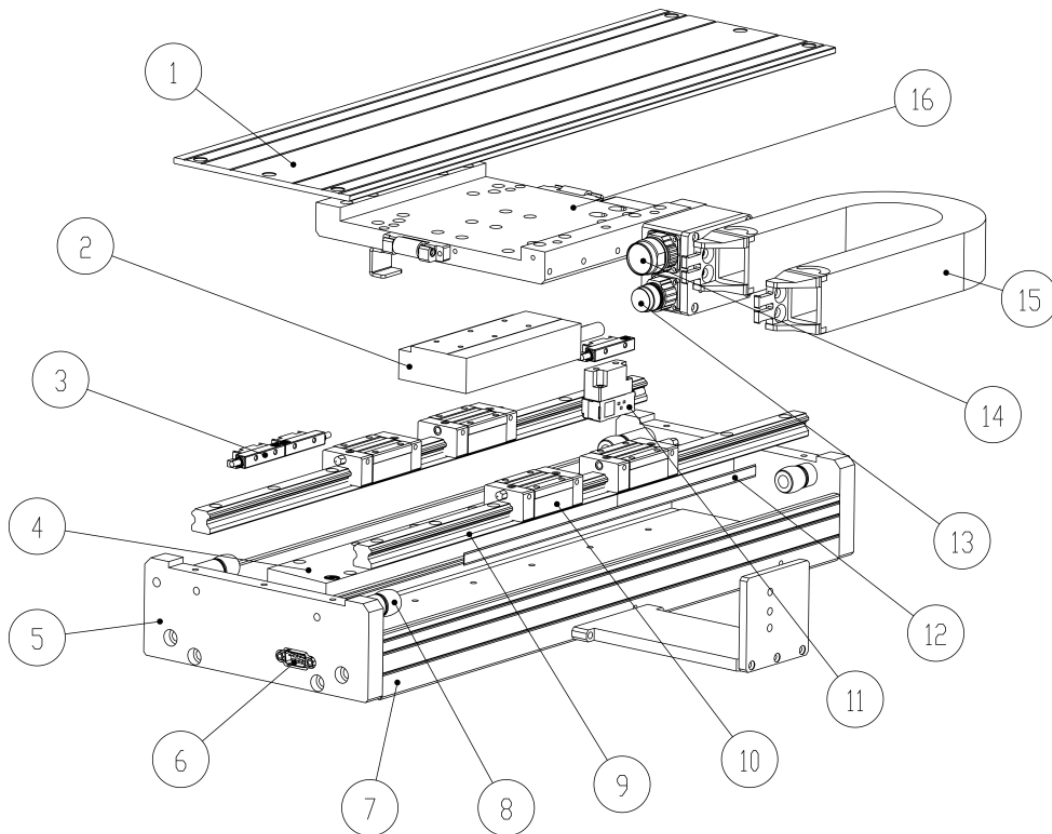

Fig. 3.1 Main components of the linear motor system – here for a LMX1A linear motor system

Table 3.1 Main components of the linear motor system

Pos.	Components	Pos.	Components
1	Cover	9	Linear guideway
2	Forcer (primary part)	10	Linear guideway block
3	Reference and limit switches with mounting bracket	11	Encoder with mounting bracket
4	Stator (secondary part of the linear motor)	12	Scale
5	End plate	13	Encoder plug coupling
6	Limit and reference switch connectors	14	Motor plug coupling
7	Base	15	Cable chain
8	Position damper	16	Forcer housing

3.3 Functional description

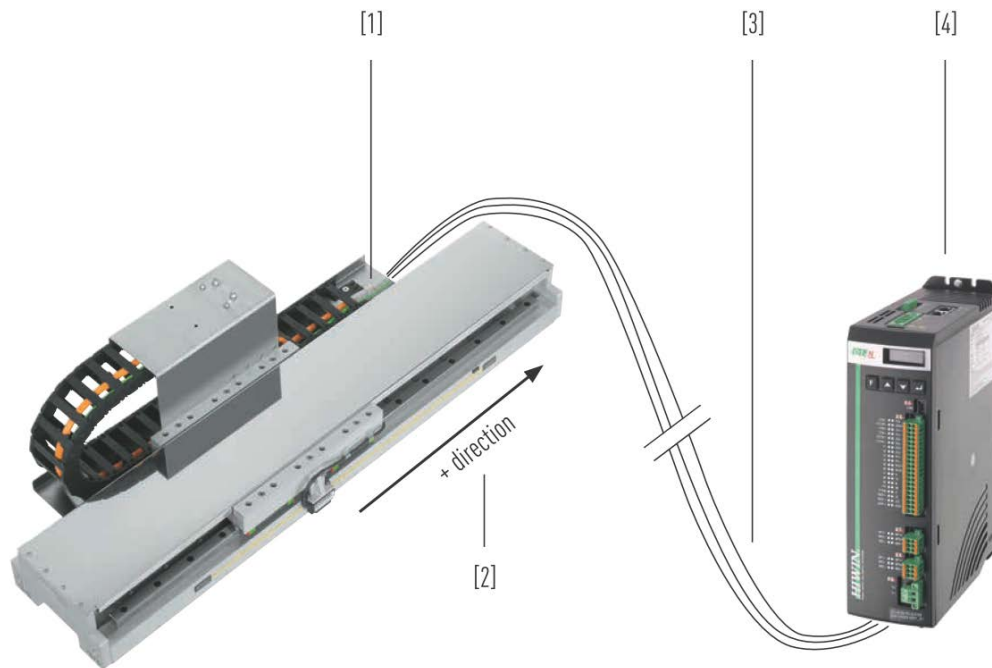

Fig. 3.2 Principle of the linear motor system

Table 3.2 Components and functionality

Pos.	Function
1	Energy supply (standard version or customer-specific version)
2	Positive (+) direction of motion. This is defined via the position of the reference switch.
3	Motor cables, positioning measurement system, limit switches.
4	<ul style="list-style-type: none"> ● Drive D1 ● Drive D1-N (with functional safety, suggested for users from Europe)

3.3.1 Linear motor system

A linear motor system comprises a base with integrated linear guideways or a base with air bearing system. These both absorb the forces exerted by the weights, accelerations, and processes and provide precise guiding for the forcer housing. The axis is driven by linear motors.

3.3.2 Linear motor

A linear motor consists of two components, the forcer (primary part) with coils and the stator (secondary part) with permanent magnets. The coils carrying alternating current generate a magnetic field that changes over time and interacts with the steady magnetic field of the stator. The resulting force is used to generate linear motion. The linear motor components are supplied as separate parts.

3.3.3 Positioning measurement system

ATTENTION!

Damage caused by scratching!

The measuring scale of the optical measuring system may be damaged by improper handling.

- ▶ Handle the measuring scale with care!

ATTENTION!

Damage to the magnetic positioning measurement system!

Strong magnetic fields and vibrations can damage the magnetic positioning measurement system.

- ▶ Protect the magnetic positioning measurement system against strong magnetic fields!
- ▶ Protect the magnetic positioning measurement system against strong vibrations!

The distance travelled is measured by a high-resolution positioning measurement system that is mounted on the base. Depending on its type, the linear motor system features an optical or a magnetic positioning measurement system. The installed positioning measurement system is fully cabled and is connected to the controller via a separate connector (See Technical Information and Approval Drawing).

NOTE Please note the documentation included with this product for positioning measurement system not described in these assembly instructions.

NOTE For assembly, disassembly, operation and cleaning, please consult the manufacturer's separate operating instructions.

3.3.4 Limit switches (optional)

Depending on the type, a few optical or inductive switches generate a signal to the controller upon reaching the end of the travel distance. The limit switches are supplied pre-wired and operational (for pin assignment see Technical Information and Approval Drawing).

3.3.5 Cable chain (optional)

The motor, limit switch, and positioning measurement system cables are routed through the cable chain to the drive.

NOTE Please observe manufacturer's instructions for retrofitting.

4. Transport and installation

4.1 Delivery

4.1.1 Delivery state

The linear motor systems are supplied fully assembled, function tested and ready for connection. To prevent damage arising during transport, the linear motor systems are provided with transportation safety devices and shipping devices.

4.1.2 Scope of delivery

For the scope of delivery, please see the contractual documentation.

4.2 Transport to the installation site

DANGER!



Danger from strong magnetic fields!

Strong magnetic fields around linear motor system pose a health risk to persons with implants (e.g. cardiac pacemakers) that are affected by magnetic fields.

- ▶ Persons with implants that are affected by magnetic fields should maintain a safe distance of at least 1 m from linear motor system

WARNING!



Risk of crushing from forcer housing!

Danger of injury from crushing and damage to the linear motor system caused by movement of the forcer housing due to gravity, as it does not feature brakes in its standard version.

- ▶ Ensure that each transportation safety devices is well fixed before transportation. In most cases, the devices are made in red.

WARNING!



Danger from gas into the eyes!

Accidentally disconnect the air tubes may damage your eyes.

- ▶ Disconnect air supply and wait for 20 seconds until the air leak out.

WARNING!



Danger from heavy loads!

Lifting heavy loads may damage your health.

- ▶ For system's weight over 20 kg, use a hoist of an appropriate size when positioning heavy loads!
- ▶ Observe applicable occupational health and safety regulations when handling suspended loads!

ATTENTION!



Risk of physical damage to watches and magnetic storage media.

Strong magnetic forces may destroy watches and magnetisable data storage media near to the linear motor system!

- ▶ Do not bring watches or magnetisable data storage media into the vicinity (<300 mm) of the linear motor system!

ATTENTION!

Damage of the linear motor system!

The linear motor system may be damaged by mechanical loading.

- ▶ No heavy load on the cover!
- ▶ No unexpected load on the air bearing system!
- ▶ No moving the forcer housing without air supply!
- ▶ Only lift the linear motor system using the shipping devices provided (Fig. 4.2)!
- ▶ For longer linear motor system, provide additional protection of the center section.
- ▶ Ensure that the linear motor system does not bend as this could permanently damage accuracy.
- ▶ During transport, do not transport any additional loads on the linear motor system!
- ▶ Secure the linear motor system and components against tilting!

NOTE Electrical equipment is designed to withstand to protect against the effects of transportation, and storage temperature within a range of -25°C to +55°C and for short periods not exceeding 24h at up to +70°C.

Steps to transport the linear motor system:

- ▶ Disconnect power supply. For product with air bearing system, disconnect air supply.
- ▶ Disconnect stage cables and air tubes.
- ▶ Remove the payload.
- ▶ Lock the forcer housing in place during transport using transportation safety devices. (Fig. 4.1 ①).
- ▶ Lock shipping devices on the linear motor system. (Fig. 4.1 ②)
- ▶ Attach all shipping devices to a suitable hoist. (Fig. 4.2)
- ▶ Ensure even load distribution while lifting.

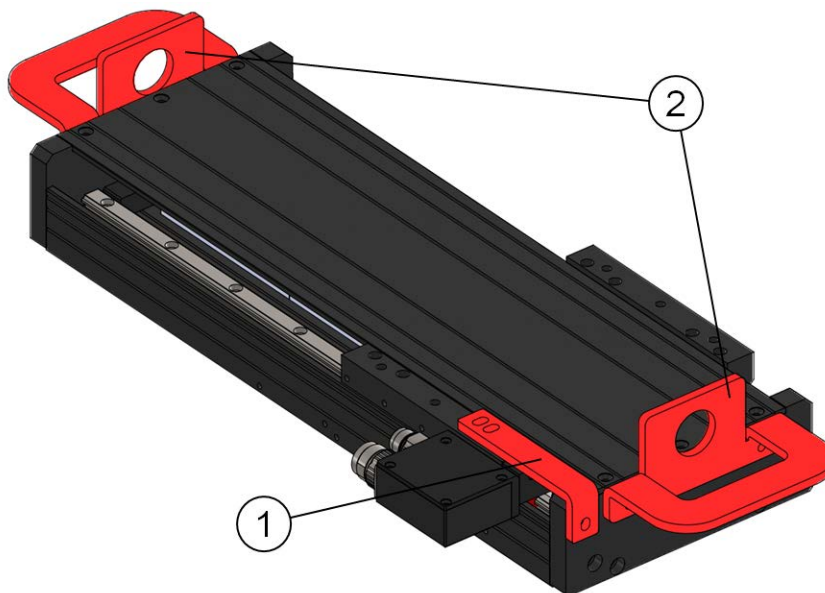

Fig. 4.1 Transportation safety device and shipping devices – here for a LMX1A linear motor system

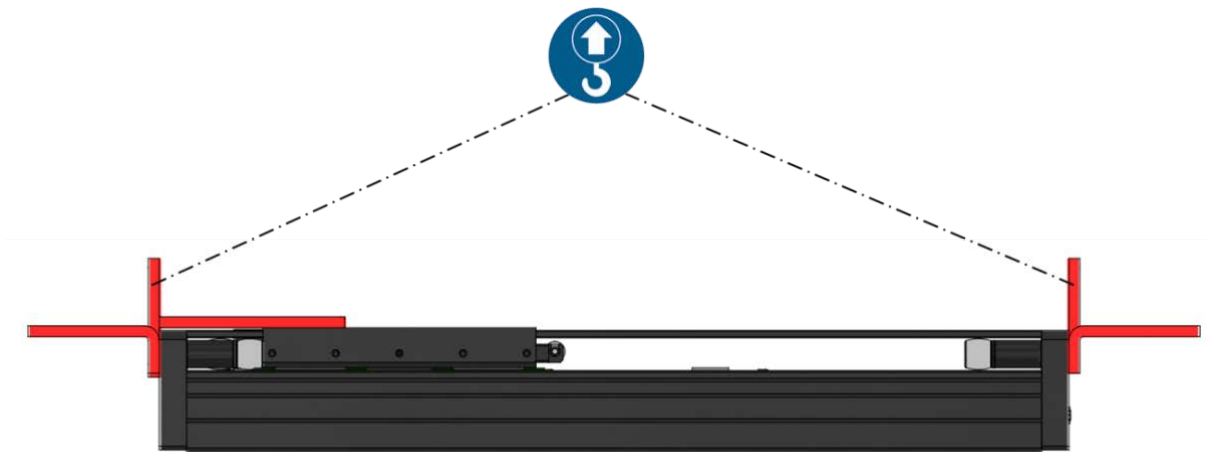

Fig. 4.2 lifting example – here for a LMX1A linear motor system

4.3 Requirements at the installation site

4.3.1 Ambient conditions

Table 4.1 Ambient condition requirement

Area of use	For indoor use only
Temperature	0 °C to 50 °C
Humidity	< 80%RH (non-condensing)
Altitude	< 1000 m
Installation site	Flat, dry, vibration-free
Protection class	IP50 and no interference from corrosive solvent or strong magnetic
Grounding	Plant power grounding line conforms to international requirements

- ▶ Avoid exposing to direct sunlight or heat rays.
- ▶ Away from electric magnetic interference source sites, such as welding, discharge machine.

4.3.2 Safety equipment to be provided by the operator

Possible safety equipment/measures:

- Personal protective equipment in accordance with regional regulations
- Zero-contact protective equipment
- Mechanical protective equipment

4.4 Storage

DANGER!

Danger from strong magnetic fields!

Strong magnetic fields around linear motor systems pose a health risk to persons with implants (e.g. cardiac pacemakers) that are affected by magnetic fields.

- ▶ Persons with implants that are affected by magnetic fields should maintain a safe distance of at least 1 m from linear motor systems.



- ▶ Store the linear motor system in its transport packaging.
- ▶ Only store the linear motor system in dry, frost-free areas with a corrosion-free atmosphere.
- ▶ Clean and protect used linear motor system before storage.
- ▶ When storing the linear motor system, attach signs warning of magnetic fields.

4.5 Unpacking and installing

ATTENTION!

Damage of attachments!

Attachments may be damaged by mechanical loading.

- ▶ Secure and manoeuvre the linear motor system using the suspension points provided!

NOTE The linear motor system may only be installed and operated indoors.

NOTE The linear motor system is designed exclusively for horizontal installation. During installation, the linear motor system must not exceed an angle of 1° as it does not feature a parking brake.

Steps to unpack and install the linear motor system:

- ▶ Remove protective film.
- ▶ Carefully transport the linear motor system on the shipping devices provided to the specified installation site.
- ▶ Ensure that the maintenance points are easily accessible.
- ▶ Dispose of packaging in an environmentally friendly way.

5. Assembly and connection

DANGER!



Danger from electrical voltage!

Before and during assembly, disassembly and repair work, dangerous currents may flow.

- ▶ Work may only be carried out by a qualified electrician and with the power supply disconnected!
- ▶ Before carrying out work on the linear motor system, disconnect the power supply and protect it from being switched back on!

DANGER!



Risk of crushing from strong forces of attraction!

There is a risk of crushing from the strong forces of attraction emitted by the stators, as they are assembled with opposing polarity!

- ▶ Assemble the stators carefully!
- ▶ Do not place fingers or objects between the stators!

WARNING!



Risk of crushing from forcer housing!

Danger of injury from crushing and damage to the linear motor system caused by movement of the forcer housing due to gravity, as it does not feature brakes in its standard version.

- ▶ Ensure that the linear motor system does not exceed 1° horizontal deviation!

WARNING!



Risk of crushing from the forcer!

Danger of injury from crushing and damage to the forcer through uncontrolled movements during assembly.

- ▶ Ensure that the forcer is locked in place during assembly using transportation safety devices!

WARNING!



Risk of crushing from strong forces of attraction!

Danger of injury from crushing and damage to the forcer or stator caused by very strong forces of attraction.

- ▶ Ensure that the forcer only comes close to the stator when the linear guideways can absorb the forces!

WARNING!



Danger from heavy loads!

Lifting heavy loads may damage your health.

- ▶ Use a hoist of an appropriate size when positioning heavy loads which are over 20 kg!
- ▶ Observe applicable occupational health and safety regulations when handling suspended loads!
- ▶ Only lift from the suspension points provided (see Section 4.2)!

ATTENTION!

Damage of the linear motor system!

The linear motor system may be damaged by mechanical loading.

- ▶ No heavy load on the cover!
- ▶ No unexpected load on the air bearing system!
- ▶ No moving the forcer housing without air supply!

NOTE The mounting surface must have a flatness of 0.03 mm over 300 mm.

NOTE The linear motor system may only be assembled by specialist personnel.

5.1 Assembling the linear motor system

NOTE Secure the screws with retaining rings to prevent them from accidentally coming loose!

Steps to assemble the linear motor system:

- ▶ Remove the shipping devices.
- ▶ Remove the transportation safety device from the forcer housing.
- ▶ Remove the cover or bellows if the mounting holes are inaccessible.
- ▶ Drill mounting holes in the mounting surface in accordance with scale drawing (see Technical Information and Approval Drawing).
- ▶ Clean mounting surface.
- ▶ Place the mounting bolts in the mounting holes and tighten them in a spiral motion from inside to outside with applied torque (See Table 5.1).
- ▶ If the cover or bellows were removed, install them back.

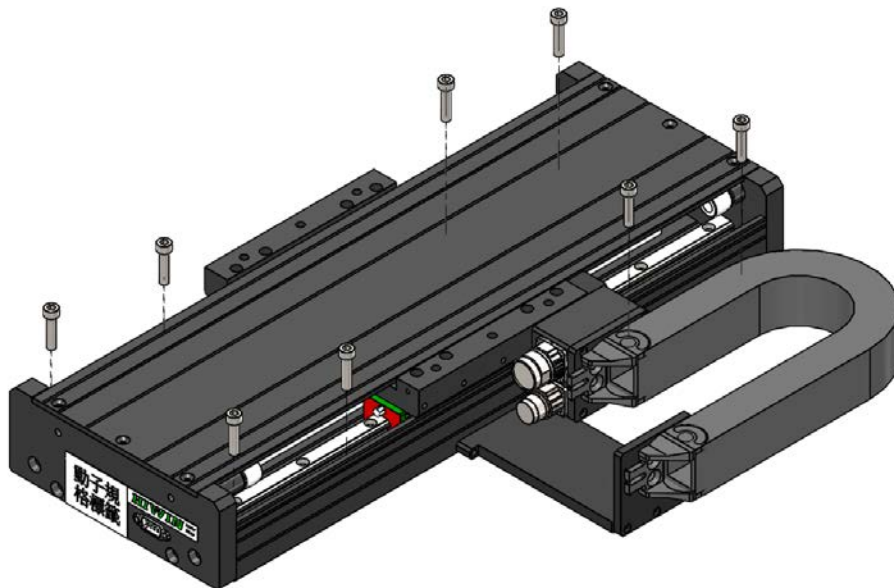

Fig. 5.1 Assembling the linear motor system – here for an LMX1A linear motor system

Table 5.1 Mounting torque

Screw Size	Torque (kgf-cm)	Screw Size	Torque (kgf-cm)
M2	5	M6	120
M2.5	10	M8	310
M3	20	M10	690
M4	40	M12	1200
M5	90	M16	2000

5.2 Assembling the moved load

Steps to assemble the moved load:

- ▶ Clean the mounting surface on the linear motor system that is to receive the load.
- ▶ Clean the mounting surface of the load.
- ▶ Position the load over the corresponding mounting holes on the mounting surface (see Technical Information and Approval Drawing).
- ▶ Place the mounting bolts in the mounting holes and tighten them in a spiral motion from inside to outside with a torque screws (See Table 5.1).
- ▶ Check the free movement of the load over the entire travel distance.

NOTE After assembling the moved load, please design another transportation safety device to lock the forcer housing in place during transport.

5.3 Air supply connection

Table 5.2 Air supply requirement

Pressure	Air supply: 6 ~ 10 bar Operating: 2 ~ 5.5 bar
Humidity	< 65%RH (non-condensing)
Air tubes	Material: Polyurethane Size: At least 4 mm inside diameter Before pressure regulating: Max. operating pressure of tube > air supply After pressure regulating: Max. operating pressure of tube > system operating pressure
Particle filter	< 5 µm

To maintain normal operation, it is recommended to use an air tank. To prevent particles from clogging the orifices of the air bearing, the compressed air must be filtered to 5 microns, keep non-condensing humidity and oil free. Before connecting to the air bearing system, the air supply should pass the pressure regulating valve. Make sure the operating pressure is within the spec (see Table 5.2).

5.4 Electrical connection

DANGER!



Danger from electrical voltage!

If linear motors are incorrectly earthed, there is a danger of electric shock.

- ▶ Before connecting the electrical power supply, ensure that the linear motor system is correctly earthed.

DANGER!



Danger from electrical voltage!

Electrical currents may flow even if the motor is not moving.

- ▶ Ensure that the linear motor system is disconnected from the power supply before the electrical connections are detached from the motors.
- ▶ After disconnecting the drive amplifier from the power supply, wait at least 5 minutes before touching live parts or breaking connections.
- ▶ For safety reasons, measure the voltage in the intermediate circuit and wait until it has fallen below 40V.

- NOTE** Observe the separate assembly instructions of the drive!
- NOTE** The supply voltage is based on the drive. Please consult the manufacturer's separate operating instructions for detailed information.

- Supplied with cabling ready for operation.
- All necessary connections via three connectors of each axis.

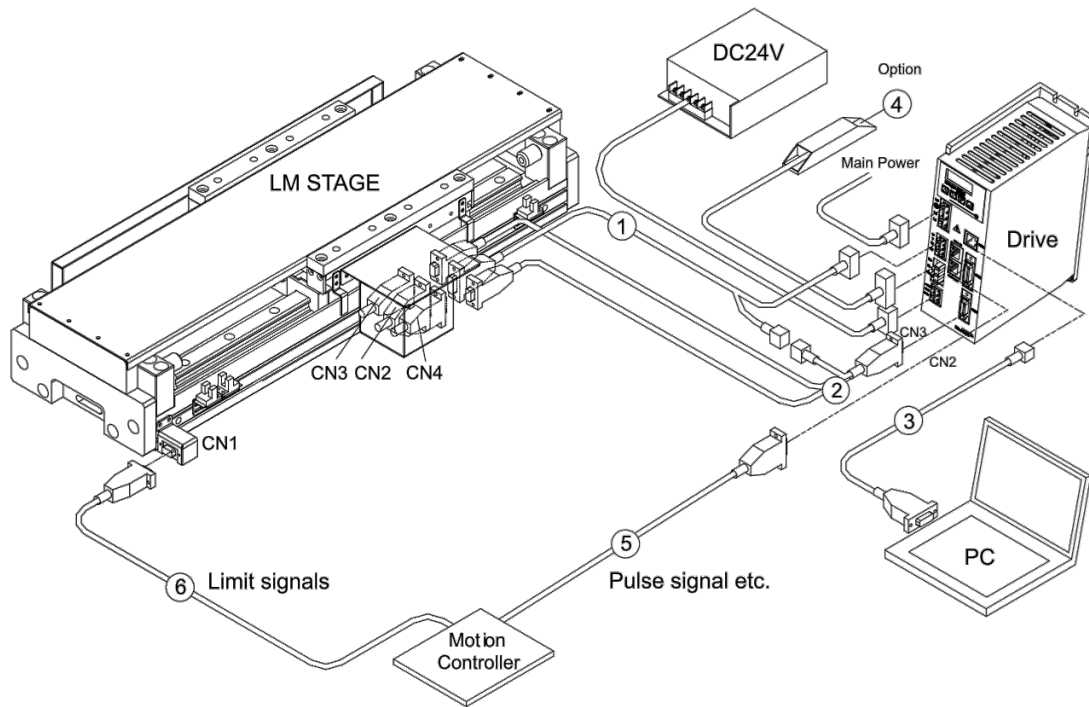

Fig. 5.2 Electrical connection for drive type of D1

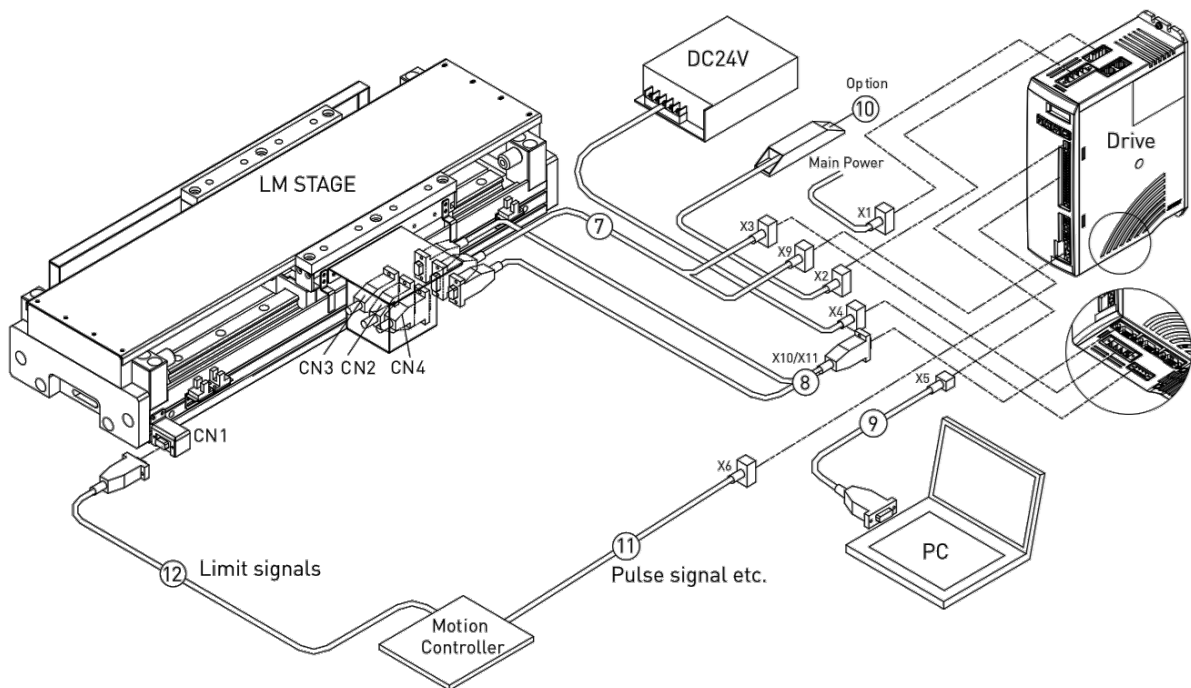

Fig. 5.3 Electrical connection for drive type of D1-N

5.3.1 Connecting iron-core motors

The temperature sensor system cable is routed as standard through the motor's extension cable. Both cables are therefore connected to the motor plug.

NOTE Observe the Technical Information and Approval Drawing for pin assignment!

5.3.2 Connecting the linear positioning measurement system

ATTENTION!

Danger of EMC interference in the encoder signal!

- ▶ Approved ESD precautions must be followed at all times during readhead and interface electrical connections.
- ▶ Make sure that the encoder cable has been shielded correctly!
- ▶ Ensure that the shielding is in full contact across the connectors!
- ▶ Ensure that the pairs of wires with the sin/cos signal are shielded separately!

The linear positioning measurement system is installed ready for operation in the linear motor system.

NOTE Observe the Technical Information and Approval Drawing for pin assignment!

5.3.3 Connecting the limit switch

The optical or inductive proximity switches in design as limit switches are installed ready for operation in the linear motor system.

NOTE Observe the Technical Information and Approval Drawing for the position of limit switches.

NOTE Observe the Technical Information and Approval Drawing for pin assignment!

6. Commissioning

6.1 Switch on the linear motor system

DANGER!



Danger from strong magnetic fields!

Strong magnetic fields around linear motor system pose a health risk to persons with implants (e.g. cardiac pacemakers) that are affected by magnetic fields.

- ▶ Persons with implants that are affected by magnetic fields should maintain a safe distance of at least 1 m from linear motor system.

WARNING!



Risk of crushing from strong forces of attraction!

Strong magnetic forces may attract steel or iron objects from the linear motor system and cause crushing!

- ▶ No heavy (> 1 kg) or large (> 0.01 m²) steel or iron objects should be introduced by hand into the immediate surrounding area (19armoni. 50 mm) of the magnet track!
- ▶ Use suitable tools only.

WARNING!



Risk of crushing from moving forcer housing!

The forcer housing may cause damage to limbs through its movement at the end position of the machine.

- ▶ The operator should provide protective equipment to prevent from reaching into the danger area of the machine!

WARNING!



Risk of burns!

The motor heats up during operation and thus touching the motor can lead to burns!

- ▶ Provide protective devices and warning notices at the motor!

WARNING!



Danger from gas into the eyes!

Accidentally disconnect the air tubes may damage your eyes.

- ▶ Disconnect air supply and wait for 20 seconds until the air leak out.

ATTENTION!



Risk of physical damage to watches and magnetic storage media.

Strong magnetic forces may destroy watches and magnetisable data storage media near to the linear motor systems!

- ▶ Do not bring watches or magnetisable data storage media into the vicinity (<300 mm) of the linear motor systems!

ATTENTION!

Damage of the linear motor system!

Danger of material damage through uncontrolled movements of the forcer housing in the case of a power cut!

- ▶ Ensure that the dampers are fitted in the end positions on both sides of the linear motor system!
- ▶ No heavy load on the cover!
- ▶ No unexpected load on the air bearing system!
- ▶ No moving the forcer housing without air supply!

NOTE The operator should provide a controller pursuant to EN ISO 12100 that prevents the machine from being started up unintentionally after power is restored, troubleshooting or the machine is stopped.

Steps to switch on the linear motor system:

- ▶ Switch off the controller.
- ▶ Pull out the motor cable.
- ▶ Connect and switch on the air supply (see Section 5.3).
- ▶ Connect positioning measurement system cable (see Section 5.3.2).
- ▶ Switch on the controller.
- ▶ Check the positioning measurement system (see separate assembly instructions for the drive and positioning measurement system).
- ▶ Switch off the controller.
- ▶ Connect the motor cable (see Sections 5.3.1).
- ▶ Switch on the controller.
- ▶ Perform test run at slow speed.
- ▶ Perform test under usage conditions.

6.2 Programming

NOTE The programming of the linear motor system depends on the controller and drive used. Observe the user manual for the controller and drive!

7. Maintenance and cleaning

DANGER!



Danger from electrical voltage!

Before and during maintenance and cleaning, dangerous currents may flow.

- ▶ Work may only be carried out by a qualified electrician and with the power supply disconnected!
- ▶ Before carrying out work on the linear motor system, disconnect the power supply and protect it from being switched back on!

DANGER!



Danger from strong magnetic fields!

Strong magnetic fields around linear motor system pose a health risk to persons with implants (e.g. cardiac pacemakers) that are affected by magnetic fields.

- ▶ Persons with implants that are affected by magnetic fields should maintain a safe distance of at least 1 m from linear motor system.

WARNING!



Risk of crushing from moving parts!

The forcer housing may cause damage to limbs through its movement at the end position of the machine.

- ▶ The operator should provide protective equipment to prevent from reaching into the danger area of the machine!

WARNING!



Risk of burns!

The motor heats up during operation and thus touching the motor can lead to burns!

- ▶ After disconnecting the drive amplifier from the power supply, wait at least 5 minutes before removing the cover and touching the motor.

WARNING!



Danger from gas into the eyes!

Accidentally disconnect the air tubes may damage your eyes.

- ▶ Disconnect air supply and wait for 20 seconds until the air leak out.

WARNING!

Unauthorized repairs on the system

Unauthorized work on the system creates the risk of injuries and may invalidate the warranty.

The system must only be serviced by specialist personnel!

ATTENTION!



Risk of physical damage to watches and magnetic storage media.

Strong magnetic forces may destroy watches and magnetisable data storage media near to the linear motor systems!

- ▶ Do not bring watches or magnetisable data storage media into the vicinity (<300 mm) of the linear motor systems!

NOTE

Use only suitable, non-hazardous agents. Please observe the manufacturer's safety data sheets.

Remove the cover or bellows before maintenance:

- ▶ As for the cover, loose the screws on the cover. As for the bellows, detach the bellows form the forcer housing.
- ▶ Remove the cover/bellows carefully.

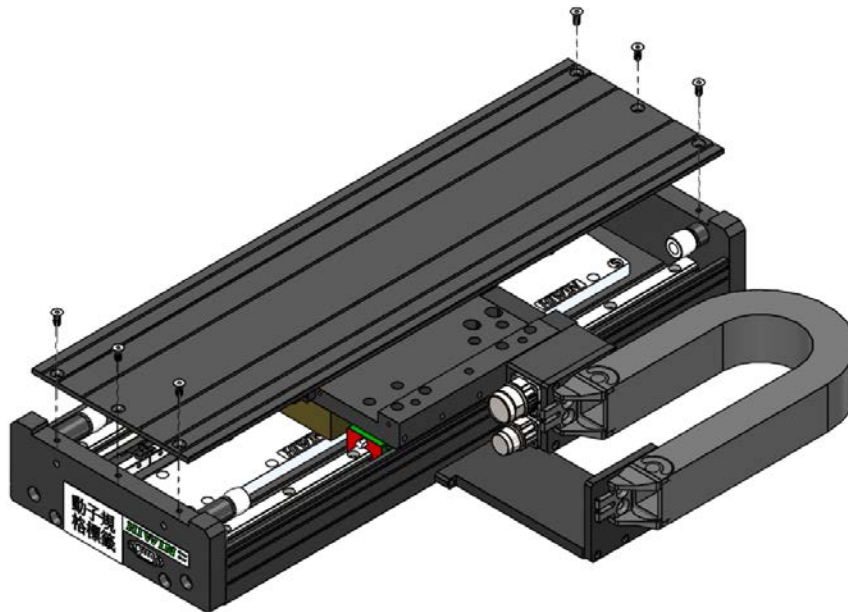

Fig. 7.1 Exploded view of the cover – here for an LMX1A linear motor system

During maintenance:

- ▶ Secure the linear motor system against being switched on without authorization.
- ▶ Disconnect the power supply of the linear motor system.
- ▶ Secure the linear motor system against being switched back on without authorization.



Fig. 7.2 Example of a warning sign

Installed the cover or bellows after maintenance:

- ▶ Position the cover or bellows on the linear motor system.
- ▶ As for the cover, tighten the screws on the cover.

7.1 Linear motor

NOTE Ensure that no parts are located between the forcer and the magnet track!

The linear motor operates maintenance-free.

7.2 Positioning measurement system

7.2.1 Magnetic positioning measurement system

NOTE Ensure that no dirt particles are located between the encoder and the measuring scale!

The magnetic positioning measurement system works on a non-contact basis and thus requires no maintenance. Check the magnetic positioning measurement system regularly for soiling, cleaning this when necessary. Otherwise, accumulating dirt particles will detach under the constant pressure of the cover plate.

7.2.2 Optical positioning measurement system

NOTE Ensure that no dirt particles are located between the encoder and the measuring scale! Only clean using a soft cloth in order to avoid scratching the measuring scale!

The optical positioning measurement system works on a non-contact basis and thus requires no maintenance. Regularly check the measuring scale for dirt and clean if necessary, as otherwise the surface of the measuring scale may become scratched and may no longer function correctly.

7.3 Electromechanical components

The energy chain and the cable have a limited lifetime. For example, the energy chain is specified for 4 million cycles. However, the lifetime cannot be calculated exactly due to ambient conditions and drive performance. The following components should therefore be regularly checked for wear and correct position, and should be replaced if necessary (wearing parts are not covered by the warranty):

- Cable in the energy chain (e.g. signs of abrasion on the cable insulation)
- Cable plug connections
- Distance between the limit switch shelter and sensors (common cause of malfunction of the limit/reference switch)

NOTE In critical production situations, make sure that there is a stock of wearing parts!

7.4 Linear guideways

7.4.1 Lubrication

As with rolling bearings, the rails of linear motor systems require a sufficient supply of lubricant. This lubrication reduces wear, protects against dirt and deposits, prevents corrosion and extends service life.

NOTE Observe the instructions of the lubricant manufacturer.

Check the miscibility of different lubricants. Lubricants of the same classification (e.g. CL) and similar viscosity (maximum difference of one class) are miscible. Greases are miscible when their base oil and thickening types are the same. The viscosity of the base oil must be similar and the NGLI class may be different by a maximum of one grade.

- NOTE** Ensure that old grease, dirt and chippings are removed from the profile rails before lubrication.
- NOTE** Only use lubricants that are in accordance with DIN 51825, KP2K of the consistency class NGLI2.
- NOTE** Ensure that only lubricants without solid lubricant particles (e.g. graphite or MoS₂) are used!
- NOTE** Further information about lubrication and selection of approved lubricants can be found in the user manual for linear guideways at www.hiwin.tw.

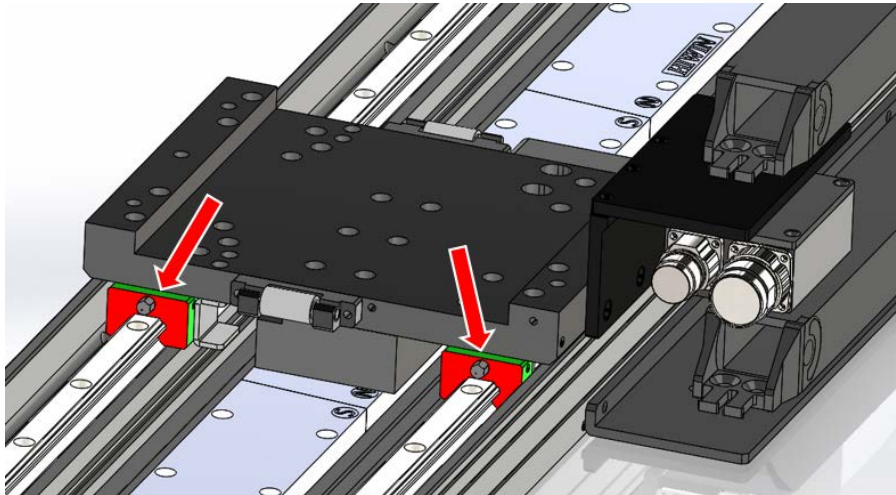

Fig. 7.3 Grease nipples on linear guideways

- Relubricating interval every 200–600 operating hours or 1000 km.
- For nominal size 20, grease quantity 0.6 g.
- Relubrication as standard through grease nipple (See Fig. 7.3) with standard grease guns.

7.4.2 Cleaning

Dirt can settle and accumulate over time on unprotected profile rails. Profile rails must therefore be regularly checked for dirt and cleaned if necessary.

7.5 Air bearing system

Dirt can settle and accumulate over time on the guiding surface of the air bearing. Guiding surface must therefore be regularly checked for dirt and cleaned if necessary.

NOTE Avoid moving the forcer housing without air supply! Connect and switch on the air supply before assembling the moved load (see Section 5.3).

NOTE Ensure that no dirt particles are located between the air bearing and the guiding surface!

Before cleaning, it is recommended that clean and dry compressed air is used to blow away small particles and dust. The guiding surface should be cleaned with isopropyl alcohol.

8. Troubleshooting

Table 8.1 Fault table

Fault	Possible cause	Remedy
Motor does not start	Supply lines disconnected	Check connections, plug contacts may be compressed, repair if necessary. The connectors have seals, which means that a certain screw connection resistance must be overcome.
	Fuse has tripped via motor protection	Check motor protection for the right settings, remedy defects if necessary
Upon restart, the drive reports a fault during commutation	Motor phases connected incorrectly	Check rotational direction
	Encoder counting direction incorrect	Change the sin and cos pair of wires in the encoder plug
	forcer housing is too close to the limit switch/limit stop	Disconnect power supply to axis and move forcer housing manually into the center of the axis.
	Additional drive resistance e.g. sealing lip, without parameter adjustment	Change parameters in the drive amplifier
Axis overspeeds upon restart	Commutation incorrect	See fault during commutation Check commutation parameters in the drive, activate speed monitoring!
	EMC interference with the encoder signal	Check the shielding of the connectors and cables
Axis overspeeds in positioning mode	Programming error in the position transfer, invalid acceleration ordered	Activate security settings in the drive amplifier, such as speed monitoring, permissible position errors etc.
Motor heats up too much (measure temperature)	Rated power exceeded as duty cycle is too long	Adapt load cycle to the rated power of the motor
	Cooling insufficient	Rectify cooling air supply or open cooling air passages, retrofit external fan if necessary
	forcer housing is difficult to move	Check lubrication of the guideways, foreign bodies in the traversing range?
	Ambient temperature too high	Observe permissible temperature range
	Load cycle has been modified	Calculate load cycle and adapt accordingly
	Drive amplifier motor commutation does not function properly	Adapt commutation parameters of the drive amplifier
Operating noise from the forcer	Relubrication required otherwise risk of bearing damage	Lubrication or consultation with HIWIN MIKROSYSTEM
The axis generates cracking noises when it is subject to control	EMC interference in the encoder signal	Encoder cables must be used separately with shielded sin and cos signal pairs
	Commutation incorrect	Optimize commutation parameters.

Table 8.1 **Fault table (continued)**

Fault	Possible cause	Remedy
The forcer jerks while moving and generates operating noise that is not caused by the profile guideways	EMC interference in the encoder signal, encoder cable plug connection defective, pin bent in plug	Place motor cable and/or encoder cable shield in full contact with the earthing terminal of the amplifier, check pin in plug
Position discrepancies after several hours of operation		Use mains filter to stabilize voltage

9. Disposal

ATTENTION!

Danger caused by environmentally hazardous substances!

The danger to the environment depends on the type of substance used.

- ▶ Clean contaminated parts thoroughly before disposal!
- ▶ Clarify the requirements for safe disposal with disposal companies and, where appropriate, with the competent authorities!



Table 9.1 **Disposal**

Fluids	
Lubricants	dispose of as hazardous waste in an environmentally friendly way
Soiled cleaning cloths	dispose of as hazardous waste in an environmentally friendly way
Linear motor system	
Cabling, electrical components	dispose of as electrical waste
PP components (e.g. cable chain)	dispose of separately
Steel components (e.g. guideways)	dispose of separately
Aluminum components (e.g. base)	dispose of separately

10. Declaration of Incorporation

Declaration of Incorporation

in the sense of the EC Machinery Directive 2006/42/EC, Annex II 1. B for partly completed machinery

The manufacturer: HIWIN MIKROSYSTEM CORP.
 Documentation department: HIWIN MIKROSYSTEM CORP.
 Address: No.6, Jingke Central Rd., Taichung Precision Machinery Park, Taichung 40852, Taiwan

Description and identification of the partly completed machine:

Product: Linear Motor System
 Type: LMX. LMG. LMAP
 Year of manufacture: from 2017

It is hereby declared that the following essential requirements of the Machinery Directive 2006/42/EC have been fulfilled.
 1.1, 1.3, 1.4, 1.5, 1.6, 1.7

Moreover, it is declared that the relevant technical documentation specified under Annex VII Part B has been compiled. It is hereby explicitly declared that the partly completed machine complies with all of the pertinent conditions in the following EC Directives.

2006/42/EC	Directive 2006/42/EC of the European Parliament and of the Council of 17 May 2006 on machinery, and amending Directive 95/16/EC (recast)
2014/30/EU	Directive 2014/30/EU of the European Parliament and of the Council of 26 February 2014 on the harmonization of the laws of the Member States relating to electromagnetic compatibility (recast)
2014/35/EU	Directive 2014/35/EU of the European Parliament and of the Council of 26 February 2014 on the harmonization of the laws of the Member States relating to the making available on the market of electrical equipment designed for use within certain voltage limits

Mounting and connecting instructions defined in catalogues and technical construction files must be respected by the user. They are based on the following standards:

EN ISO 12100:2010	Safety of machinery - General principles for design - Risk assessment and risk reduction
EN 60204-1:2006/AC:2010	Safety of machinery - Electrical equipment of machines - Part 1: General requirements
EN 61000-6-2:2005	Electromagnetic compatibility (EMC) - Part 6-2: Generic standards - Immunity for industrial environments
EN 61000-6-4:2007/A1:2011	Electromagnetic compatibility (EMC) - Generic standards -Emission standard for industrial environments

The manufacturer or the authorized person undertakes to transmit, in response to a reasoned request by the national authorities, the relevant documentation on the partly completed machinery.

This is without prejudice to the intellectual property rights of the manufacturer!

Important note! The partly completed machinery may not be commissioned until it has been ascertained that the machinery into which this partly completed machinery is to be incorporated is compliant with the provisions of this Directive.

Taichung 40852, Taiwan
 June 2017

(Place, Date)

Kou-I, Szu
 General Manager

(Surname, first name, and function of signatory)



(Signature)