

Linear Motor System

Technical Information





Linear Motor Stage

- Automated transport / AOI application / Precision / Semiconductor
- With Iron-core
 - Coreless Type
 - Linear Turbo LMT
 - Planar Servo Motor
 - Air Bearing Platform
 - X-Y Stage
 - Gantry Systems



Linear Motor

- Machine tool / Touch panel industry / Semiconductor industry / Laser manufacturing machine / Glass cutting machine
- Ironcore linear motor-LMFA series, LMSA series, LMSC series
 - Ironless linear motor-LMC series, LMT series



Torque Motor & Direct Drive Motor

- Machine Tools
- Torque Motor--TMRW Series
- Inspection / Testing Equipment / Robot
- Direct Drive Motor--DMS, DMY, DMN Series



AC Servo Motor & Drive

- Semiconductor / Packaging machine / SMT / Food industry / LCD
- Drives-D1, D2T/D2T-LM, E1
 - Motors-50W-2000W



Linear Actuator

- Hospital bed / Automatic window / Home care facility / Riveting / Press-fitting / Surface checks / Bending
- Servo Actuator-LAA series
 - LAM series
 - LAS series
 - LAN series
 - LAC series

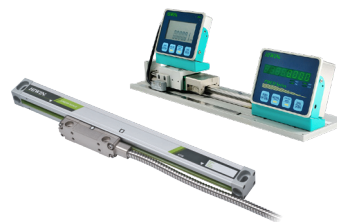

Positioning Measurement System

- Cutting machines / Traditional gantry milling machines / Programmable drilling machines
- High Resolution
 - Signal Translator
 - High-precision Enclosed
 - High Efficiency Counter



Multi-Axis Robot

- Pick-and-place / Assembly / Array and packaging / Semiconductor / Electro-Optical industry / Automotive industry / Food industry
- Articulated Robot
 - Delta Robot
 - SCARA Robot
 - Wafer Robot
 - Electric Gripper
 - Integrated Electric Gripper
 - Rotary Joint



Single-Axis Robot

- Precision / Semiconductor / Medical / FPD
- KK, SK
 - KS, KA
 - KU, KE, KC



Torque Motor & Rotary Table

- Medical / Automotive industry / Machine tools / Machinery industry
- RAB Series
 - RAS Series
 - RCV Series
 - RCH Series



Ball Screw

- Precision Ground / Rolled
- Super S series
 - Super T series
 - Mini Roller
 - Ecological & Economical lubrication Module E2
 - Rotating Nut (R1)
 - Energy-Saving & Thermal-Controlling (C1)
 - Heavy Load Series (RD)
 - Ball Spline

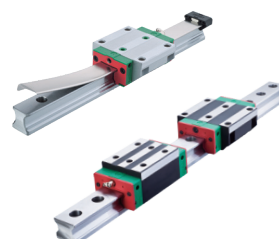

Linear Guideway

- Automation / Semiconductor / Medical
- Ball Type--HG, EG, WE, MG, CG
 - Quiet Type--QH, QE, QW, QR
 - Other--RG, E2, PG, SE, RC

Contents

Linear motor system

1. Technical Information 04

Brief Introduction to proper nouns.

2. Standard linear motor stage 06

Standard single, X-Y, gantry and air bearing stages are constructed by ironcore or ironless motor. HIWIN can quickly provide the following products :

2.1 Positioning stage _____	6
2.2 SA:low center of gravity, high payload _____	8
2.3 LMC:high-precision, high-speed stability _____	26
2.4 LMT:lightweight, high acceleration/deceleration ____	38
2.5 X-Y stage _____	54
2.6 Gantry stage _____	59
2.7 Air bearing stage _____	62

3. Customized positioning stage 66

A sampling of customized solutions is shown here. With various combinations of standard single axis stage, it may constitute a number of different linear stages. We can also provide customized products according to customer demand.

4. Drives 101

Brief introduction to HIWIN standard drive D1 and D1-N.

Appendix 115

The inquiry form at the end of this catalogue helps us know customer's demand, so that we can make a preliminary design.

A : Motor sizing _____	115
B : Optional regeneration resistors _____	118
C : Inquiry form (Mechanical system) _____	120
D : Inquiry form (Electronical control system) _____	121



SA : low gravity center, high payload

Linear motor SA stages are equipped with ironcore motor(s) and well suited for applications that require point to point precision positioning and larger payload.



LMC : high-precision, high-speed stability

Linear motor LMC stages are equipped with coreless motor(s) and well suited for applications that require precision positioning and constant velocity scanning motion.



LMT : middle precision, light payloads

Linear motor LMT stages are equipped with a coreless shaft motor, which perfectly replace the combination of ball screw and AC servo motor, and improve max. speed greatly.

1 Technical Information

1.1 Glossary

Back emf constant (K_v)

This is the ratio of the back emf voltage (rms) to the motor rotational speed or linear speed (rpm or m/s). The back emf is the electromagnetic force, which is created at the movement of the coil in the magnetic field of permanent magnets, e.g. in a servo motor.

Acceleration

This is the speed change per time unit, i.e., acceleration = speed / time or $a = v / t$.

Acceleration time

This is defined as the time a drive requires from start until achieving maximum speed.

Vertical straightness

The measure of straightness when moving in X-axis. If there is deviation in vertical straightness, there would be positioning error in Z-axis, as the system moves along X-axis.

Torque

This is a measurement of the rotational movement in a body and consequently a vectorial direction that can be expressed in the following cross product: $\vec{M} = \vec{r} \times \vec{F}_1$
The torque is expressed in the equation $Nm = kg \times m^2/s^2$.

Repeatability

Repeatability should not be confused with absolute accuracy. A linear axis can have medium accuracy, but have good repeatability. Uni-directional repeatability can be measured in a way, that a target position is approached multiple times from an appropriately distance and the same approaching direction. In this way, the backlash will not have any effect. For measurement of bi-directional repeatability, the target position is approached from different directions, in which case the backlash will take effect.

Motor constant (K_m)

This designates the ratio of generated force and dissipation power, represents the efficiency of the motor.

Stiffness

This corresponds to the mechanical resistance to deformation a part or an assembly can provide under external static payload. (static stiffness) Or, it is the elastic resistance to deformation a part or an assembly can provide under external dynamic payload. (dynamic stiffness)

Horizontal straightness

The measure of straightness when moving in X-axis. If there is deviation in horizontal straightness, there would be positioning error in Y-axis, as the system moves along X-axis.

Guide deviation

This is the deviation from the axis of stroke. It depends on horizontal straightness (also straightness) and vertical straightness (also flatness).

Force, torque

Force (in linear movements) or torque (in rotational movements) is given for defined conditions, e.g., as continuous force or torque at:

- 20 °C ambient temperature
- 80 °C winding temperature
- 100% rate of loading(duty cycle)

or as peak force or peak torque.

Force constant (K_f)

This is a coil specific constant. The motor output force can be calculated by multiplying the force constant of the motor by input current: $F = I \times K_f$

Continuous torque, continuous force (F_c)

Or also nominal torque, nominal force. This is the torque or force, that rotary or linear motors can produce in continuous operation when continuous current of 100% load rate(duty cycle) is applied to the motor coil.

Continuous current (I_c)

It is a current that flows over longer time into motor. The maximum allowed current into each coil is also called nominal current. It is characterized when the generated heat results in motor warming of up to 80 °C.

Resolution

It is the smallest distance, that the position measuring system will detect. The reachable step size is, in principle, larger than resolution due to other additional factors.

Eccentricity

This is the deviation of the center point of rotation of rotary tables from their position during rotation. It is created by centering and bearing tolerances.

Step size

Also called resolution. It is the smallest possible movement of a system. It depends on encoder, amplifier, mechanical construction, backlash, etc.

Accuracy

This, or actually the better terminology, the inaccuracy, corresponds to the deviation between target and actual position. The accuracy along an axis is defined as the remaining difference of target and actual position, after other linear deviations are excluded. Such systematic or linear deviations can be caused by cosine error, angle deviation, ball screw error, thermal expansion, etc. For all target positions of interest in an application, it is calculated with the following formula:

Maximum of sum of systematic target-actual-difference + 2 sigma (standard deviation)

Please do not confuse accuracy with repeatability.

Attraction force (F_a)

This is created between the primary and secondary parts of the ironcore linear motors which must be taken up by the guide.

Winding resistance R_{25}

This is the coil-specific dimension of is the winding resistance at 25 °C. At 80 °C, the winding resistance increases to approximately $1.2 \times R_{25}$.

Winding temperature (T)

This is the permitted winding temperature. The actual motor temperature is dependent on the installation, cooling and operating conditions and consequently can only be determined in a concrete case and cannot be calculated.

Wobbling

It is a term for rotary motor. Wobble is the angular deviation of rotating axis from theoretical axis of rotation as the motor turns. The reason for it is possibly bearing tolerances.

Peak current (I_p)

This current is applied to coils for a short time to generate peak force. The maximum time for applying peak current is 1 second. After that, motor has to cool down to nominal operating temperature, before further peak current could be applied again.

Peak torque, peak force (F_p)

The peak torque (for rotary motion) or peak force (for linear motion) is the maximum force that a motor can generate for approximately one second with peak current I_p . While applying I_p into motor, it is operating near the non-linear range of motor. This is especially useful for acceleration and braking.

2 Standard linear motor stage

2.1 Positioning stage

HIWIN offers a variety of positioning stages, such as single axis, X-Y double axis, bridge, gantry and X-Y-Z-axis Cartesian robots, to meet a variety of automation application needs. All above positioning stages use self-made key components, such as linear motors, linear slide, ball screw, direct drive motors, servo motors and drives. Therefore, HIWIN positioning stages can achieve the best performance and the most effective cost, can significantly enhance the competitiveness of our customers. HIWIN's diversified positioning stages have been widely used in various technical fields, such as optical detection, laser processing, plastic material coating, metal processing and other automated production equipment. Industrial fields cover semiconductor industry, optical elements, panel displays, medical equipment, machine tools, electronic components, MEMS and so on.

Rich specifications and quick customized ability to fully meet customers mass production, shorten product development process and strict application environment, high specification requirements.



2.1.1 Single axis positioning stage

HIWIN single axis positioning stage provides fast, accurate positioning, linear direct drive motor and can reach long stroke applications, in addition to providing metal cover, dust jacket and other optional items to achieve dust protection requirements. Choose cable chain type, horizontal or vertical wiring that uses extension cords not to scatter outside, make the machine look tidy.

Depend on different linear motors, those can be further divided into the following different types:

	<p>SA : low gravity center, high payload</p> <p>Linear motor SA stages are equipped with ironcore motor(s) and well suited for applications that require point to point precision positioning and larger payload.</p>
	<p>LMC : high-precision, high-speed stability</p> <p>Linear motor LMC stages are equipped with coreless motor(s) and well suited for applications that require precision positioning and constant velocity scanning motion.</p>
	<p>LMT : middle precision, light payload</p> <p>Linear motor LMT stages are equipped with a coreless shaft motor, which perfectly replace the combination of ball screw and AC servo motor, and improve max. speed greatly.</p>

2.1.2 Measurement standards

All the precision measurement data provided by HIWIN are measured at temperature at 23 °C ± 1 °C, humidity at 55% ± 5% environmental, and the position feedback system of positioning stages apply 1µm resolution optical scale.

2.1.3 Cable chains: horizontal/vertical orientation

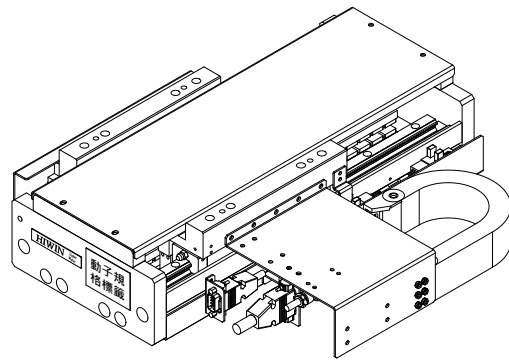

Cable chain horizontal orientation

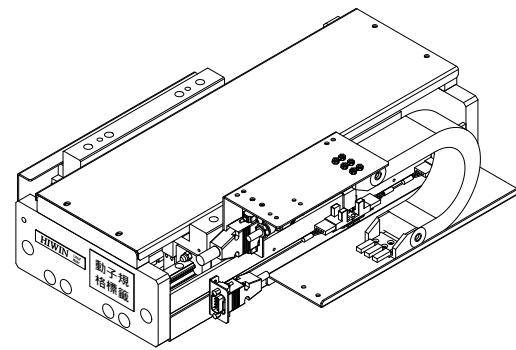

Cable chain vertical orientation

2.2 SA low gravity center, high payload

Linear motor SA stages are equipped with ironcore motor(s) and well suited for applications that require point to point precision positioning and larger payload.

- It offers larger continuous force, especially for larger force and fast applications
- Stroke range up to 4m
- Superior speed control characteristic
- Low cost, small size, high performance
- Suitable for clean rooms



2.2.1 SA

LMX1A-SA11-1-800-G 1 E-V1 3-CL

<p>Stage type LMX1A</p> <p>Motor type SA11: LMSA11 SA21L: LMSA21L SA12: LMSA12 SA22L: LMSA22L SA13: LMSA13 SA23L: LMSA23L SA21: LMSA21 SA31L: LMSA31L SA22: LMSA22 SA32L: LMSA32L SA23: LMSA23 SA33L: LMSA33L SA31: LMSA31 SA32: LMSA32 SA33: LMSA33</p> <p>The number of slider 1: 1</p> <p>Stroke 100: 100mm 600: 600mm 200: 200mm 700: 700mm 300: 300mm 800: 800mm 400: 400mm 900: 900mm 500: 500mm 1000: 1000mm</p> <p>Encoder type 0:None A:40µm analogical 1Vpp optical scale E:TTL digital 1µm resolution magnetic scale G:TTL digital 1µm resolution optical scale(standart) K:TTL digital 0.1µm resolution optical scale</p> <p>Limit switch 1:Inductive type · PNP · NC 2:Inductive type · NPN · NC C:Customized</p> <p>Limit switch connector type E:Connector is mounted on edge of stage S:Connector contains 300mm extension cord</p> <p>Cable chain N:None V1:Vertical, chain internal space is 21x25mm V2:Vertical, chain internal space is 21x38mm V3:Vertical, chain internal space is 21x50mm V4:Vertical, chain internal space is 21x68mm H1:Horizontal, chain internal space is 21x25mm H2:Horizontal, chain internal space is 21x38mm</p> <p>Extension cable 0:None 3:3m 5:5m 7:7m (Includes limit switch extension cable)</p> <p>Additional option None:Standard C:Customized request CL:Centralized lubrication</p> <p>Note · Contact HIWIN for customized specification.</p>	<p>1</p> <p>E</p> <p>V1</p> <p>3</p> <p>CL</p>
--	---

Low profile

SA series stage reduced maximum 38% stage height.

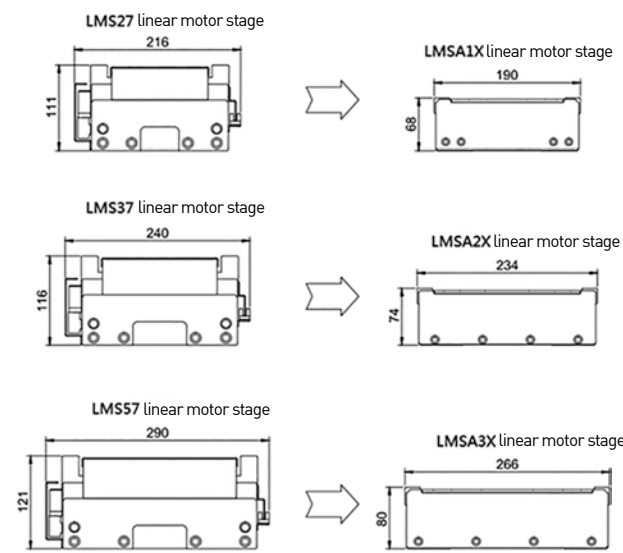

High force

SA series stage offers maximum 2469N peak force.

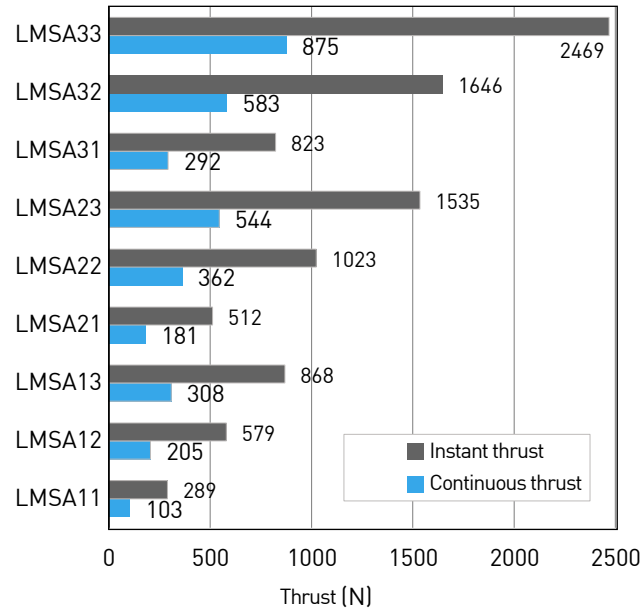

High acceleration/deceleration

Acceleration / deceleration up to 140 m/s² [14G].
Actual acceleration / deceleration might be limited by linear guideway life consideration.

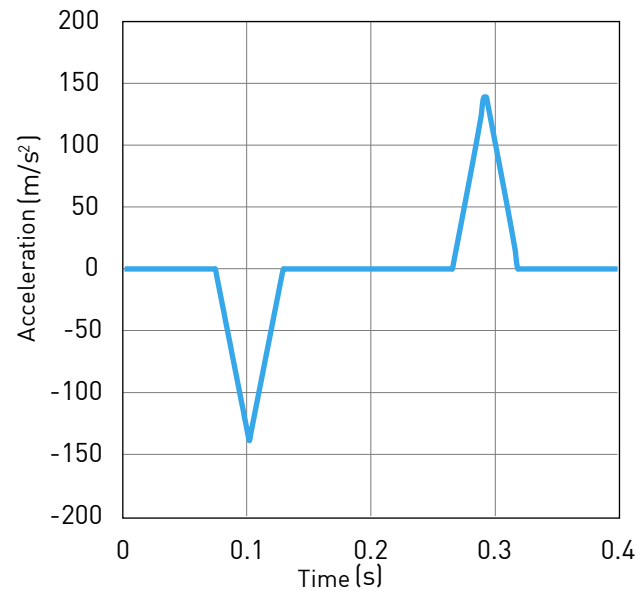

High static stability

Position stability is within ±0.1µm (measured by laser interferometer, the result is depended on environment condition.).

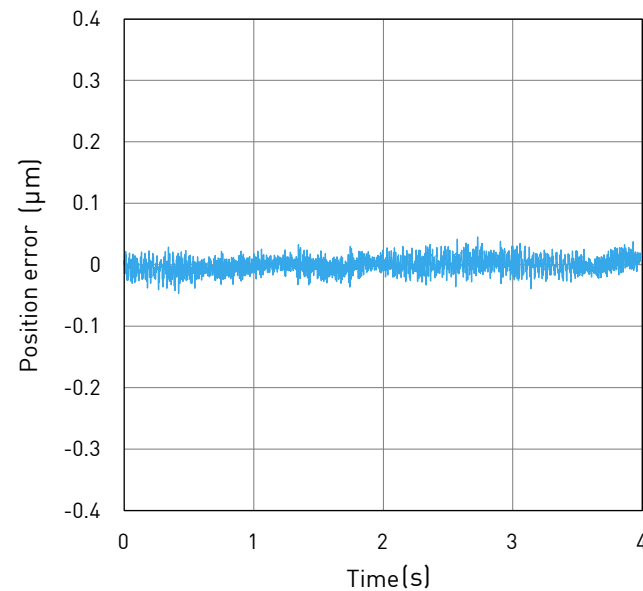

2.2.2 SA series stage SA11,SA12,SA13

Table2-1 SA11,12,13 stage specification

Specification	SA11	SA12	SA13
Continuous force, F_c (N)	103	205	308
Peak force, F_p (N)	289	579	868
Stroke (mm)	100~1000(mm)		
Resolution	0.1µm / 1.0µm / Analog 1Vpp		
Repeatability (µm) *2	Digital 1µm encoder / Analog encoder: ± 1		
	Digital 0.1µm encoder: ± 0.5		
Accuracy (µm) *2,3	Digital 1µm encoder / Analog encoder: ± 2		
	Digital 0.1µm encoder: ± 1		
Horizontal straightness (µm)	10 / 500 mm		
Vertical straightness (µm)	20 / 500 mm		
Moving mass (kg)	5	6	8
Loading capacity (kg)	10	20	30

Force-Velocity Curve(DC bus = 325V)*4

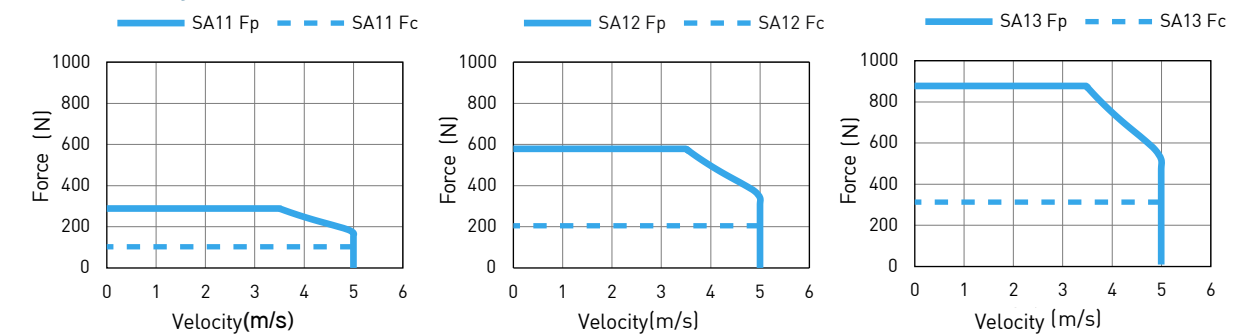

Force-Velocity Curve(DC bus = 600V)*4

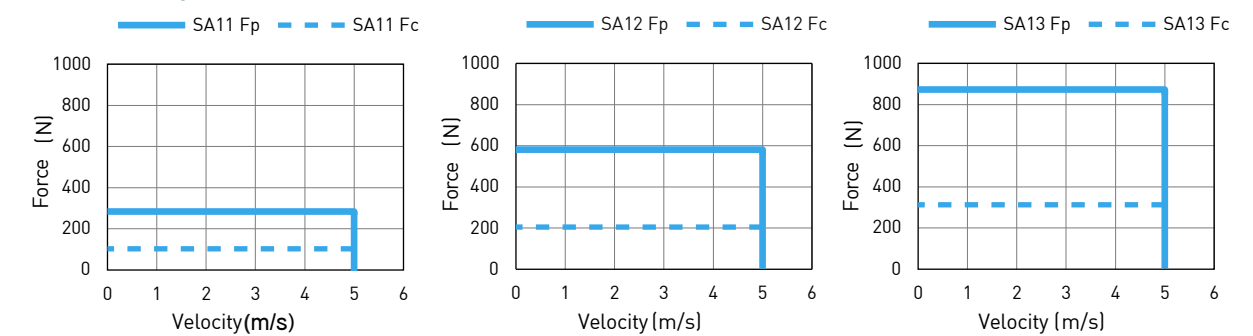

Acceleration-Payload Curve

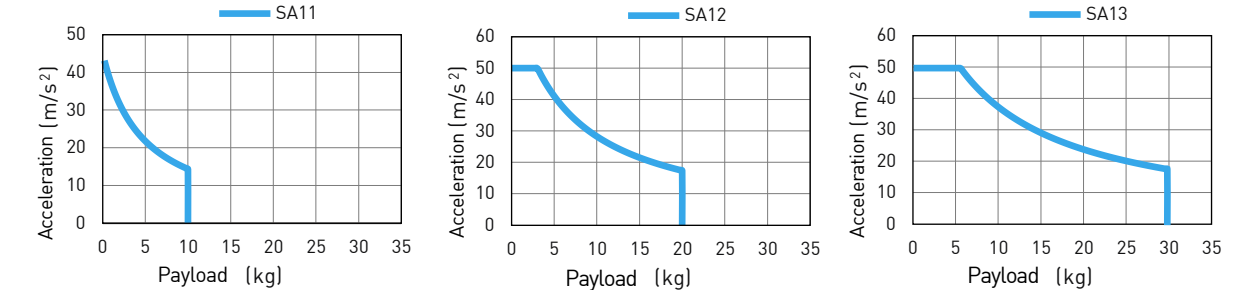

*1 : All values are measured on a granite table, all stage mounting holes are well fixed.
*2 : Values are measured according to HIWIN measuring standard.
*3 : After error compensation.

*4 : The Force-Velocity Curve is the characteristic curve of the motor. The actual velocity will change with stroke, payload and acceleration. Please refer to the Velocity-Stroke Curve or Appendix A : Motor Sizing.
*5 : All specifications above are standard, contact HIWIN for special request.

Velocity-Stroke Curve

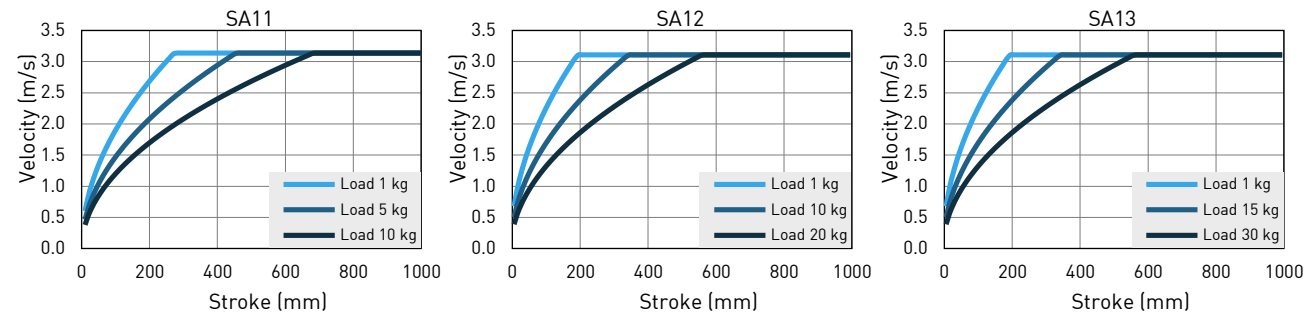

Cantilever Load Capability*2,3

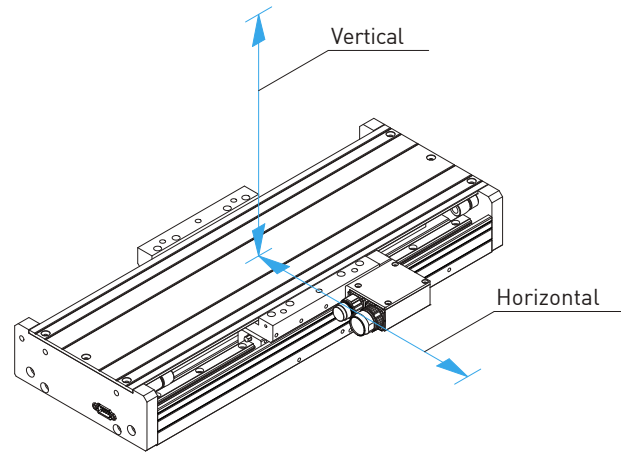

Vertical

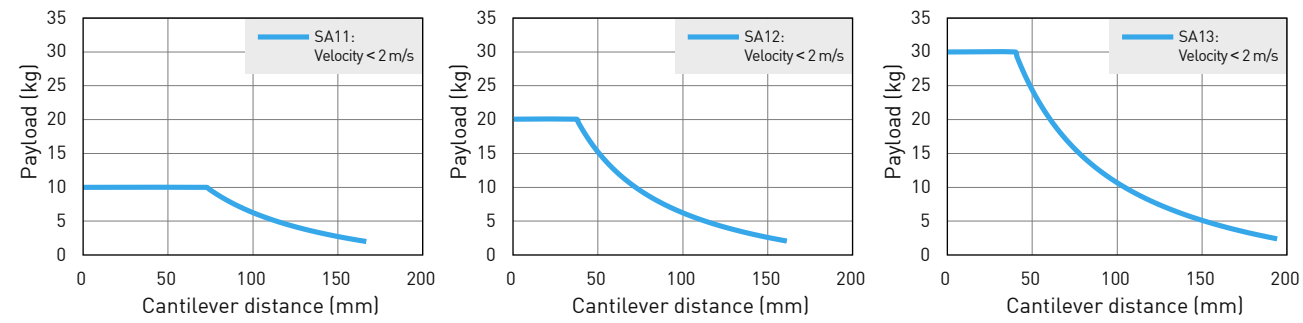

Horizontal

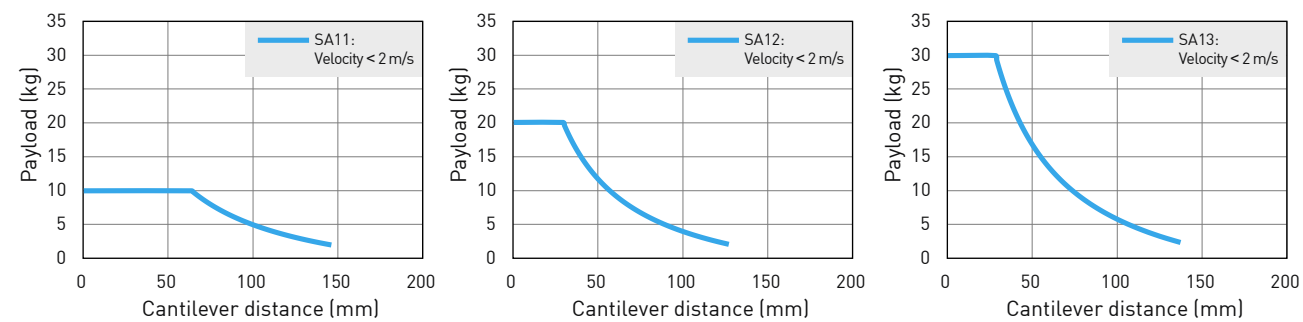

*1 : All values above are standard, contact HIWIN for special request.
*2 : Cantilever load capability due to different positioning stage, application rated life also vary.
*3 : The main reason for lifetime derives from linear guideway. For more details, please refer to HIWIN linear guideway catalog.

SA11 Linear motor stage dimensions

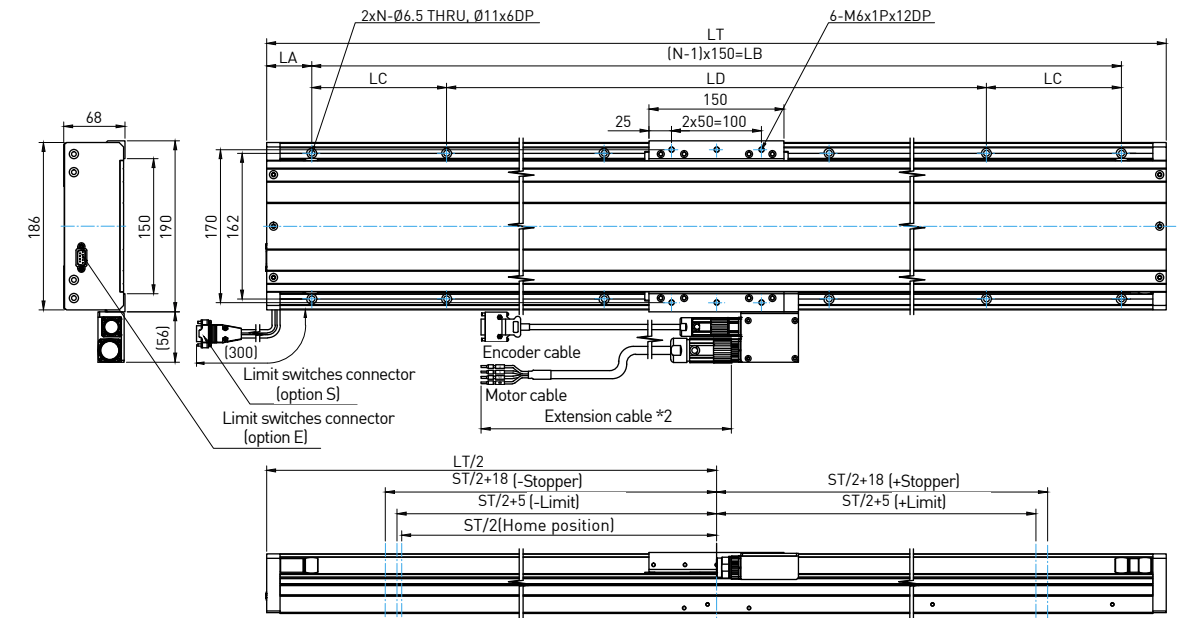

Linear motor stage with horizontal chain

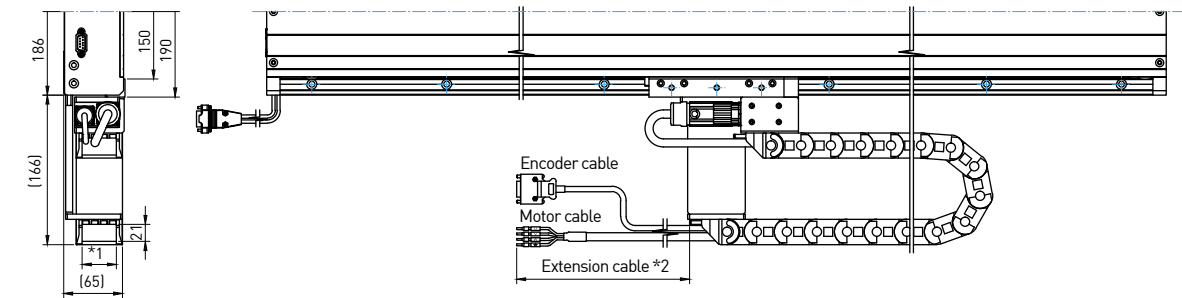

Linear motor stage with vertical chain

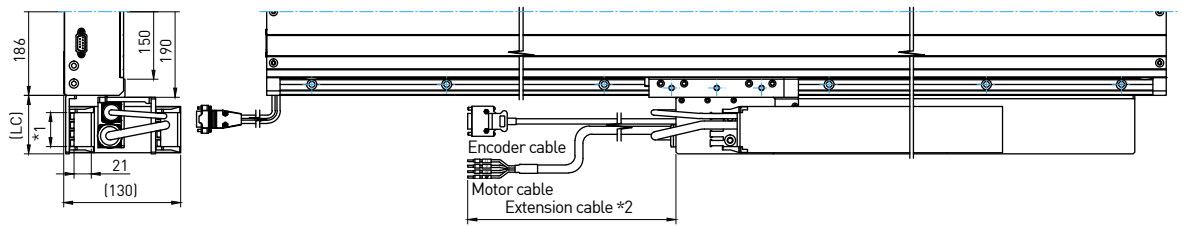
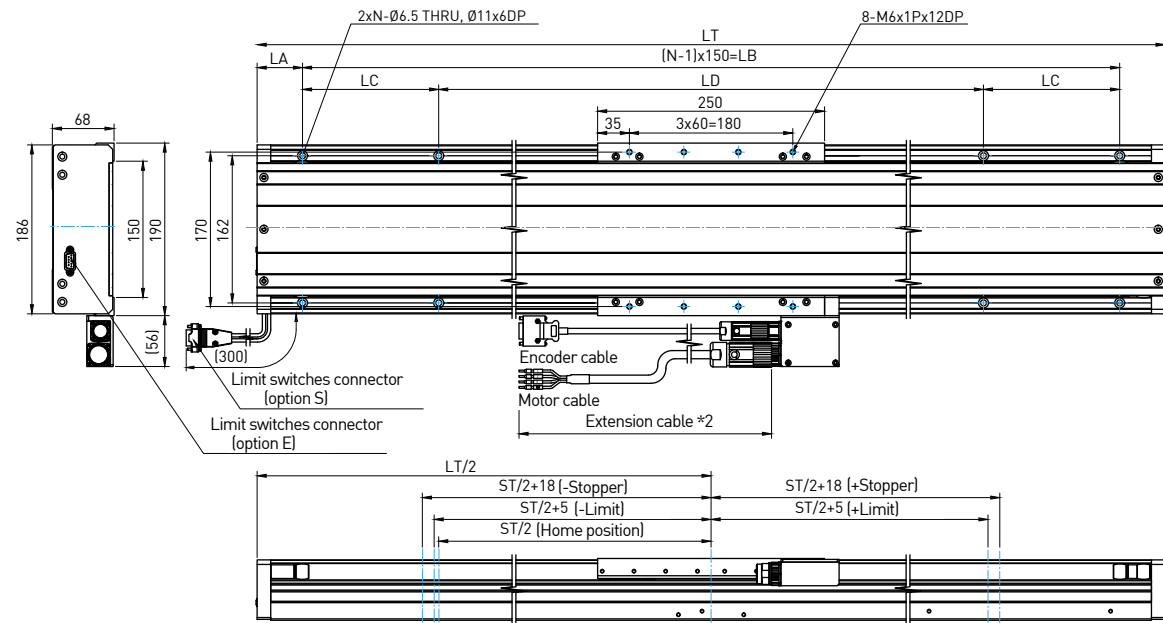

Table2-2 SA11

Stroke(mm)	N	LT	LA	LB	LC	LD	LC(cable chain)	
							V1,V2*3	V3,V4*3
100	4	400	25	-	100	150	65	95
200	4	500	25	-	100	250		
300	4	600	65	-	100	270		
400	5	700	75	-	150	250		
500	6	800	25	750	-	-	65	95
600	6	900	75	750	-	-		
700	7	1000	50	900	-	-		
800	8	1100	25	1050	-	-		
900	8	1200	75	1050	-	-		
1000	9	1300	50	1200	-	-		

*1:Cable chain interior width is selected from ordering information.
*2:Extension cable length is selected from ordering information.
*3:Dimension LC is determined by cable chain interior width V1-V4 from ordering information.

SA12 Linear motor stage dimensions



SA13 Linear motor stage dimensions

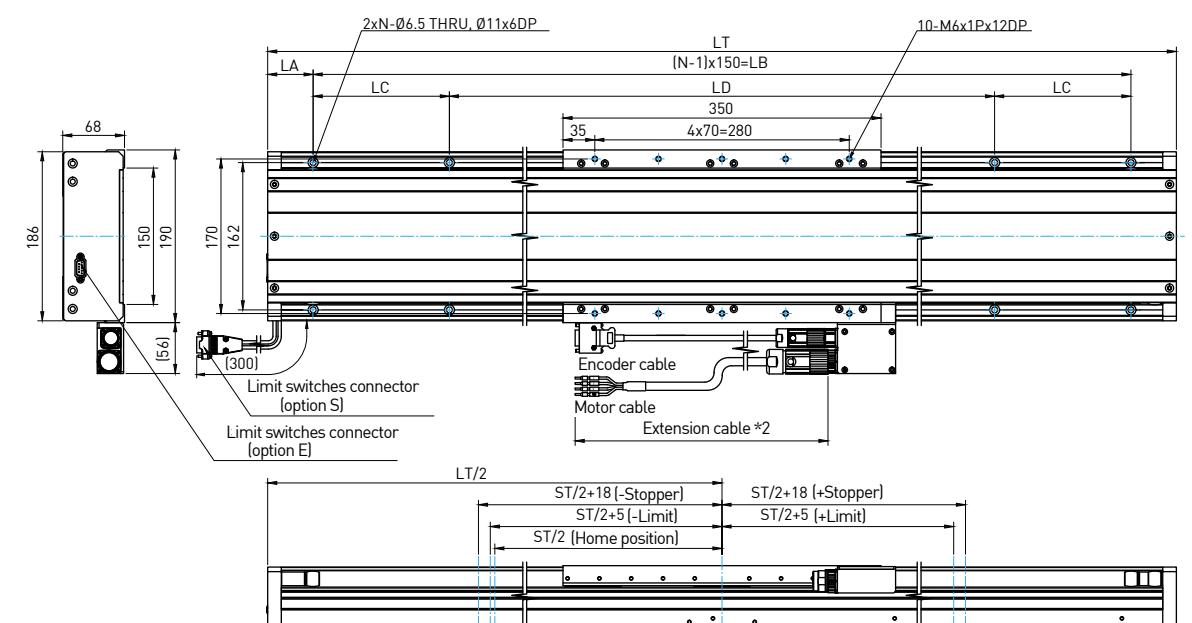

Linear motor stage with horizontal chain

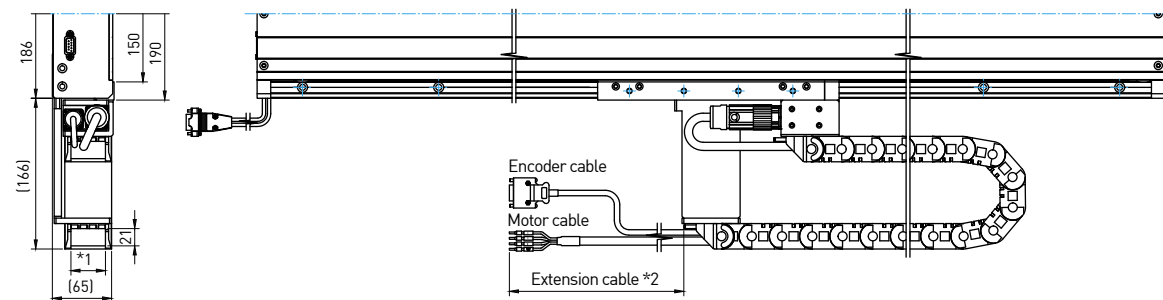

Linear motor stage with horizontal chain

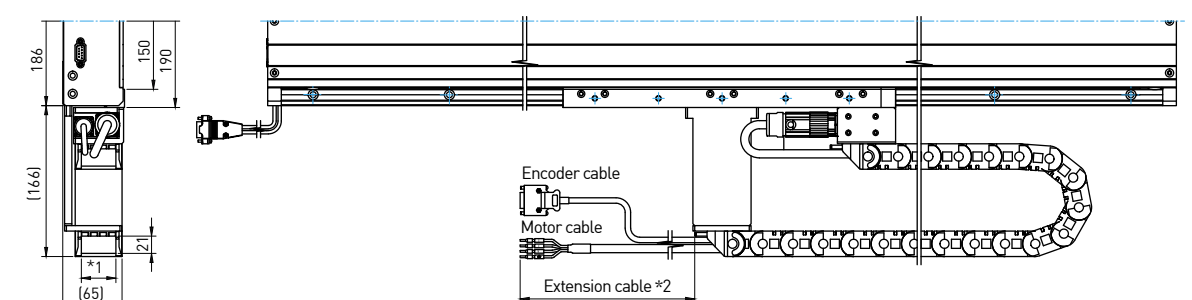

Linear motor stage with vertical chain

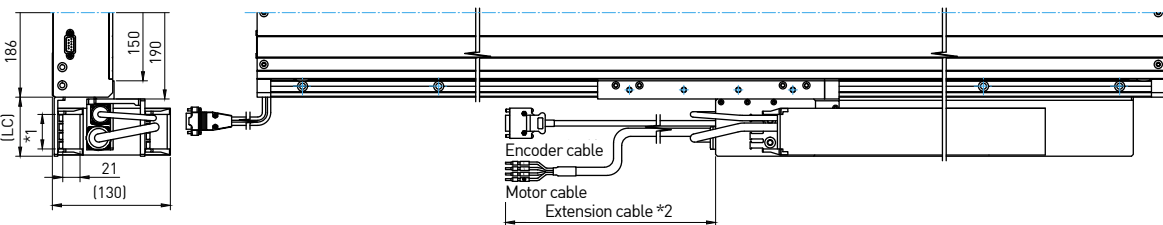

Linear motor stage with vertical chain

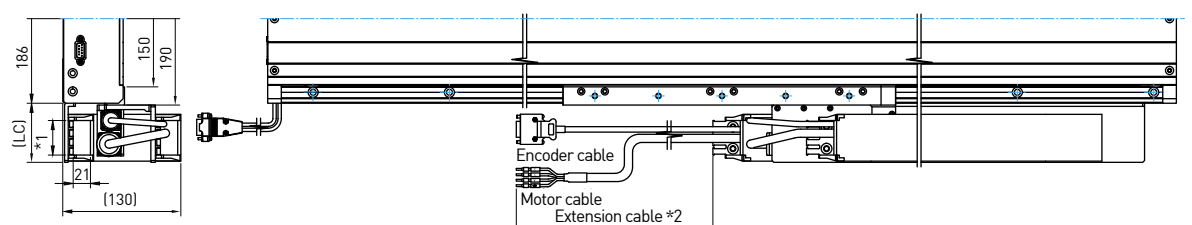

Table2-3 SA12

Stroke(mm)	N	LT	LA	LB	LC	LD	LC(cable chain)	
							V1,V2*3	V3,V4*3
100	4	500	25	-	100	250	65	95
200	4	600	65	-	100	270		
300	4	700	75	-	150	250		
400	6	800	25	750	-	-		
500	6	900	75	750	-	-		
600	7	1000	50	900	-	-		
700	8	1100	25	1050	-	-		
800	8	1200	75	1050	-	-		
900	9	1300	50	1200	-	-		
1000	10	1400	25	1350	-	-		

*1:Cable chain interior width is selected from ordering information.
*2:Extension cable length is selected from ordering information.
*3:Dimension LC is determined by cable chain interior width V1-V4 from ordering information.

Table2-4 SA13

Stroke(mm)	N	LT	LA	LB	LC	LD	LC(cable chain)	
							V1,V2*3	V3,V4*3
100	4	600	65	-	100	270	65	95
200	4	700	75	-	150	250		
300	6	800	25	750	-	-		
400	6	900	75	750	-	-		
500	7	1000	50	900	-	-		
600	8	1100	25	1050	-	-		
700	8	1200	75	1050	-	-		
800	9	1300	50	1200	-	-		
900	10	1400	25	1350	-	-		
1000	10	1500	75	1350	-	-		

*1:Cable chain interior width is selected from ordering information.
*2:Extension cable length is selected from ordering information.
*3:Dimension LC is determined by cable chain interior width V1-V4 from ordering information.

SA21,SA22,SA23

Specification	SA21	SA21L	SA22	SA22L	SA23	SA23L
Continuous force, F_c (N)	181	181	362	362	544	544
Peak force, F_p (N)	512	512	1023	1023	1535	1535
Stroke (mm)	100~1000					
Resolution	0.1 μ m / 1.0 μ m / Analog 1Vpp					
Repeatability (μ m) *2	Digital 1 μ m encoder / Analog encoder: \pm 1					
	Digital 0.1 μ m encoder: \pm 0.5					
Accuracy (μ m) *2,3	Digital 1 μ m encoder / Analog encoder: \pm 2					
	Digital 0.1 μ m encoder: \pm 1					
Horizontal straightness (μ m)	10 / 500 mm					
Vertical straightness (μ m)	20 / 500 mm					
Moving mass (kg)	6		8		11	
Loading capacity (kg)	30		40		50	

Force-Velocity Curve(DC bus = 325V)*4

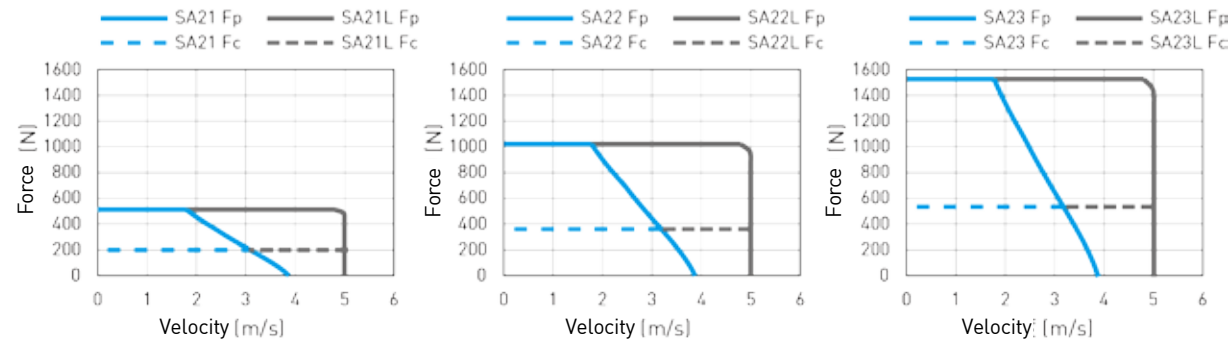

Force-Velocity Curve(DC bus = 600V)*4

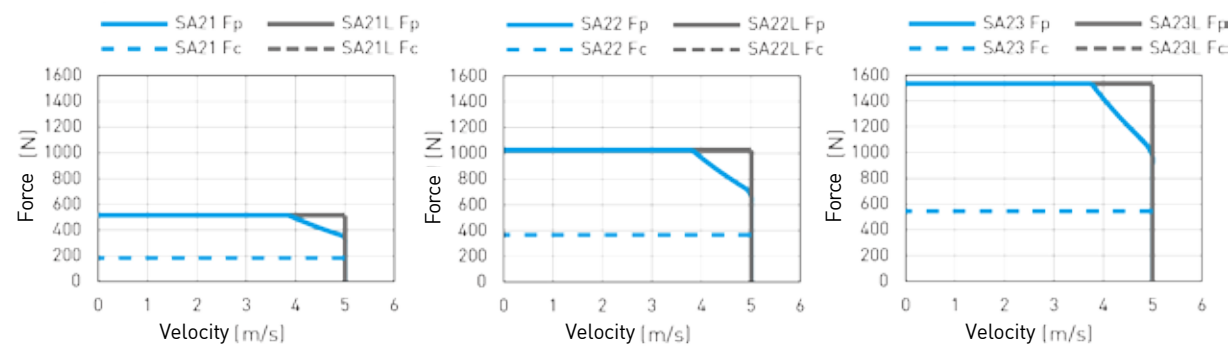

Acceleration-Payload Curve

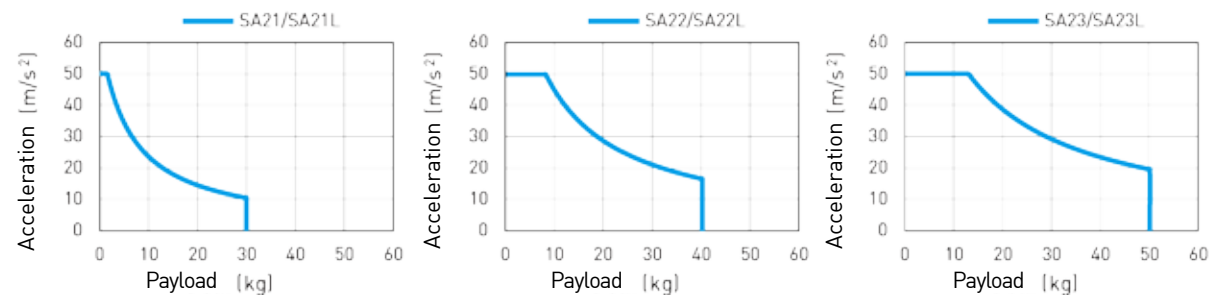

*1 : All values are measured on a granite table, all stage mounting holes are well fixed.
*2 : Values are measured according to HIWIN measuring standard.
*3 : After error compensation.

*4 : The Force-Velocity Curve is the characteristic curve of the motor. The actual velocity will change with stroke, payload and acceleration. Please refer to the Velocity-Stroke Curve or Appendix A : Motor Sizing.
*5 : All specifications above are standard, contact HIWIN for special request.

Velocity-Stroke Curve

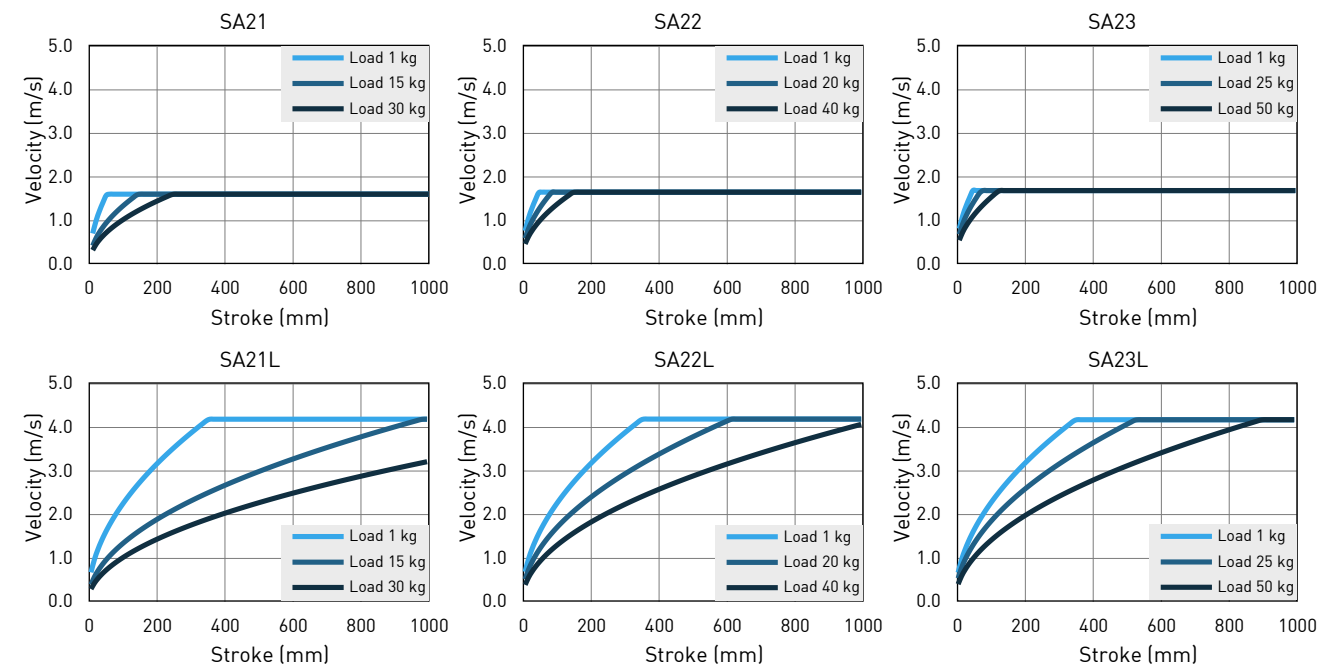

Cantilever Load Capability*2,3

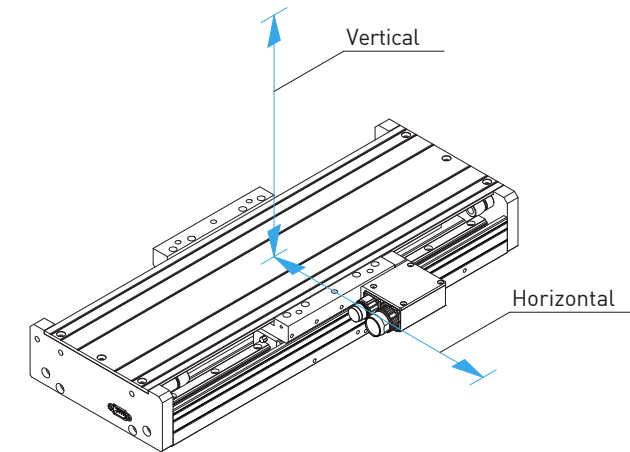

Vertical

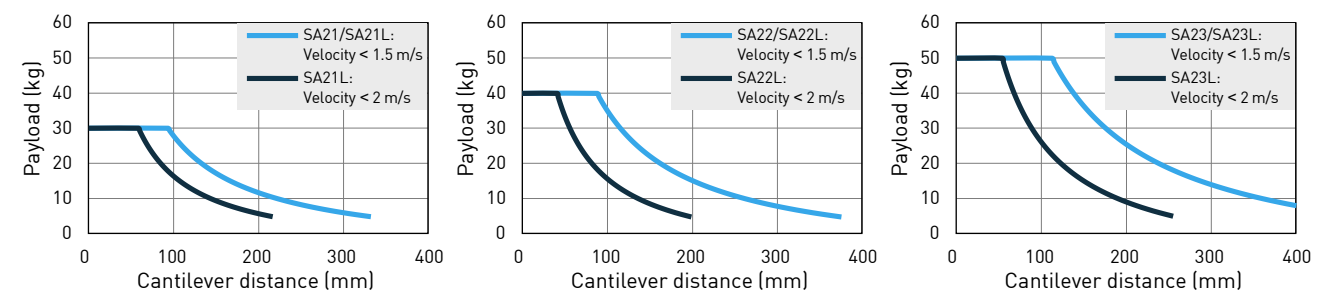

Horizontal

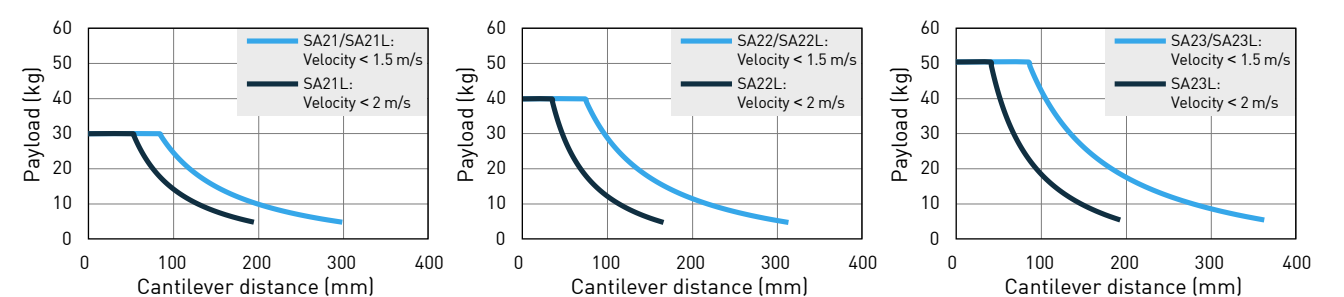

*1 : All values above are standard, contact HIWIN for special request.
*2 : Cantilever load capability due to different positioning stage, application rated life also vary.
*3 : The main reason for lifetime derives from linear guideway. For more details, please refer to HIWIN linear guideway catalog.

SA21 Linear motor stage dimensions

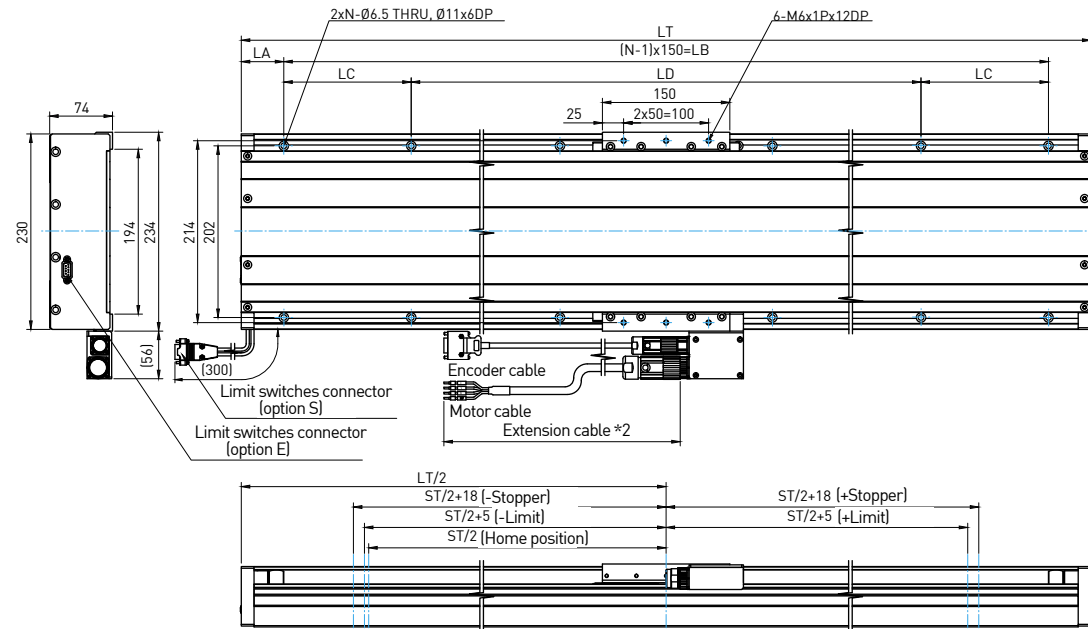

SA22 Linear motor stage dimensions

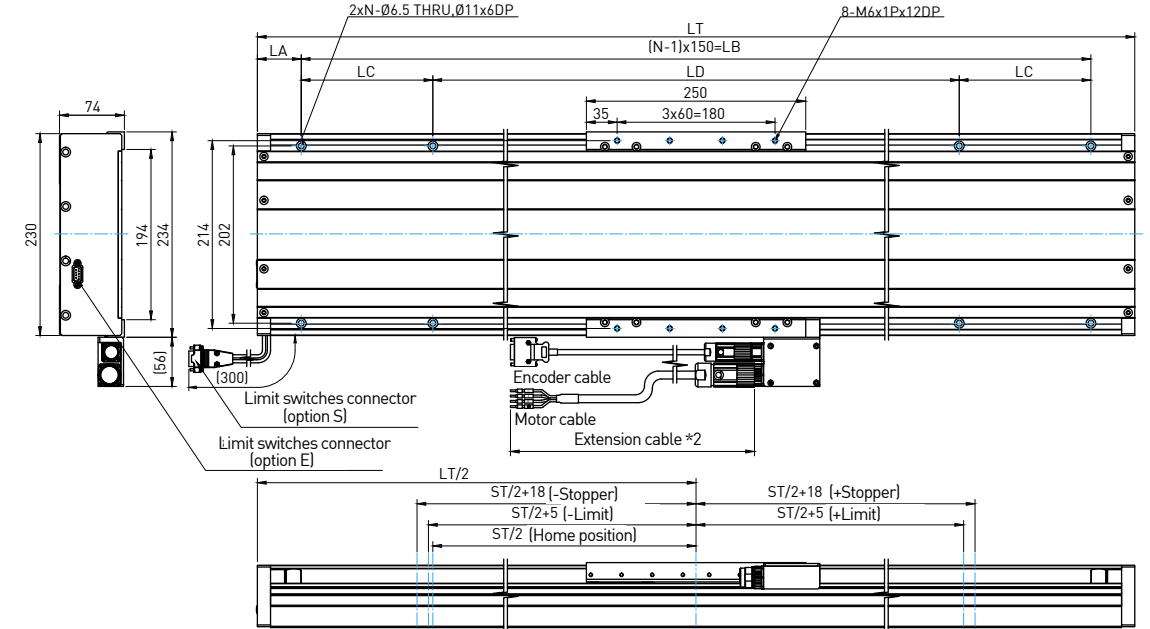

Linear motor stage with horizontal chain

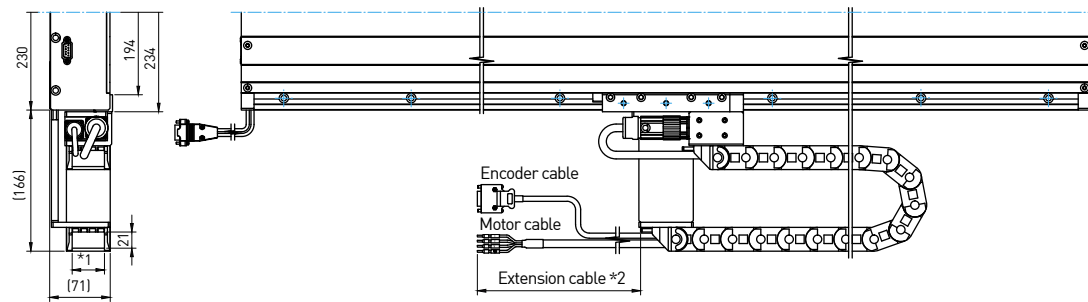

Linear motor stage with horizontal chain

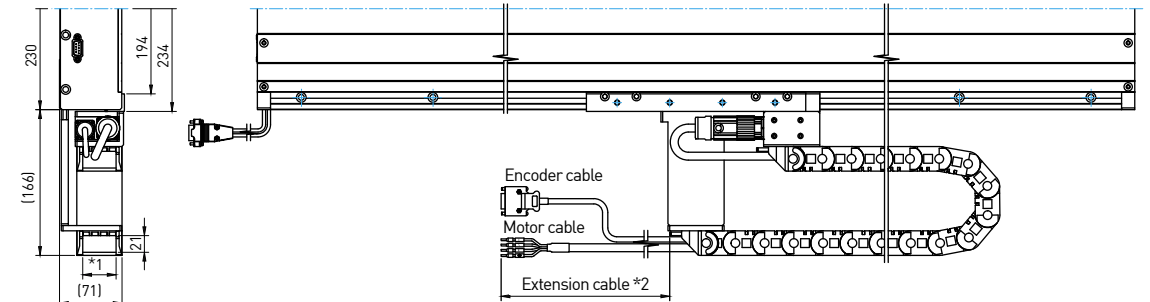

Linear motor stage with vertical chain

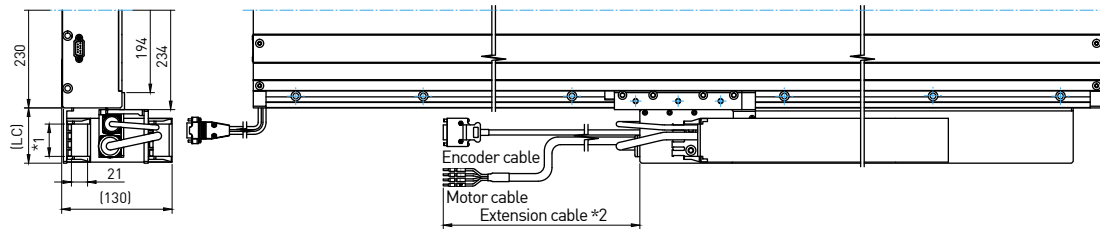

Linear motor stage with vertical chain

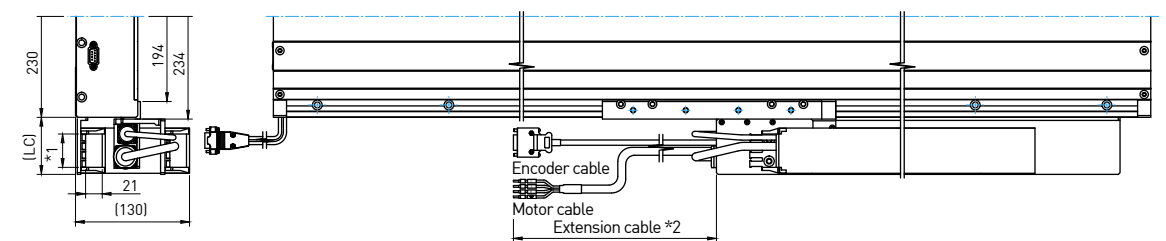

Table2-6 SA21

Stroke(mm)	N	LT	LA	LB	LC	LD	LC(cable chain)	
							V1,V2 ^{*3}	V3,V4 ^{*3}
100	4	400	25	-	100	150	65	95
200	4	500	25	-	100	250		
300	4	600	65	-	100	270		
400	5	700	75	-	150	250		
500	6	800	25	750	-	-		
600	6	900	75	750	-	-		
700	7	1000	50	900	-	-		
800	8	1100	25	1050	-	-		
900	8	1200	75	1050	-	-		
1000	9	1300	50	1200	-	-		

*1:Cable chain interior width is selected from ordering information.

*2:Extension cable length is selected from ordering information.

*3:Dimension LC is determined by cable chain interior width V1-V4 from ordering information.

Table2-7 SA22

Stroke(mm)	N	LT	LA	LB	LC	LD	LC(cable chain)	
							V1,V2 ^{*3}	V3,V4 ^{*3}
100	4	500	25	-	100	250	65	95
200	4	600	65	-	100	270		
300	4	700	75	-	150	250		
400	6	800	25	750	-	-		
500	6	900	75	750	-	-		
600	7	1000	50	900	-	-		
700	8	1100	25	1050	-	-		
800	8	1200	75	1050	-	-		
900	9	1300	50	1200	-	-		
1000	10	1400	25	1350	-	-		

*1:Cable chain interior width is selected from ordering information.

*2:Extension cable length is selected from ordering information.

*3:Dimension LC is determined by cable chain interior width V1-V4 from ordering information.

SA23 Linear motor stage dimensions

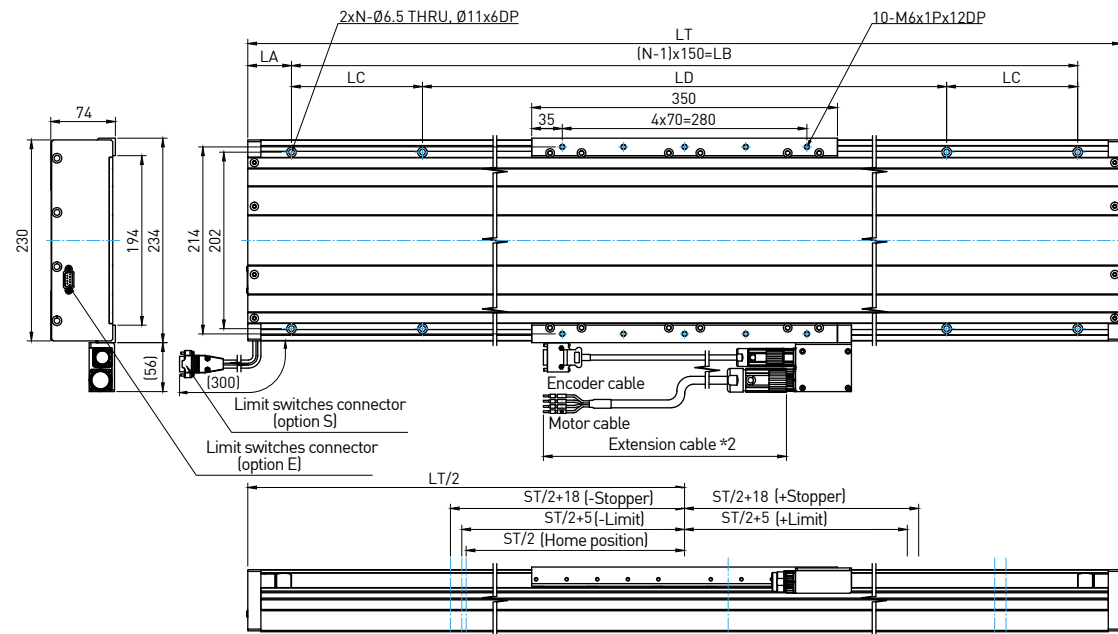

Linear motor stage with horizontal chain

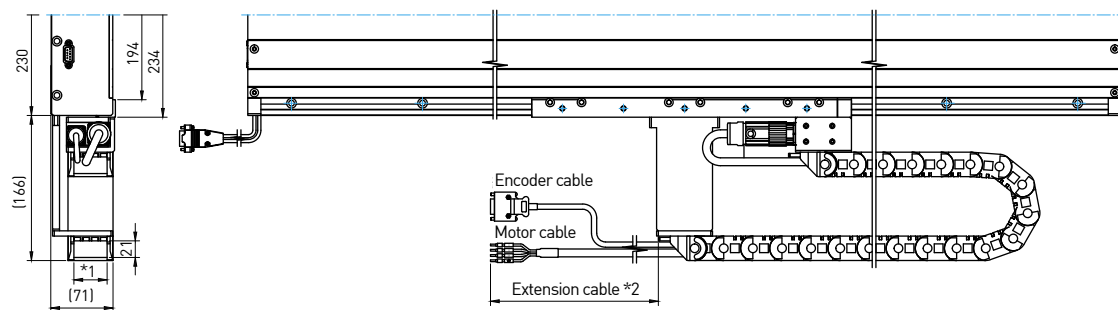

Linear motor stage with vertical chain

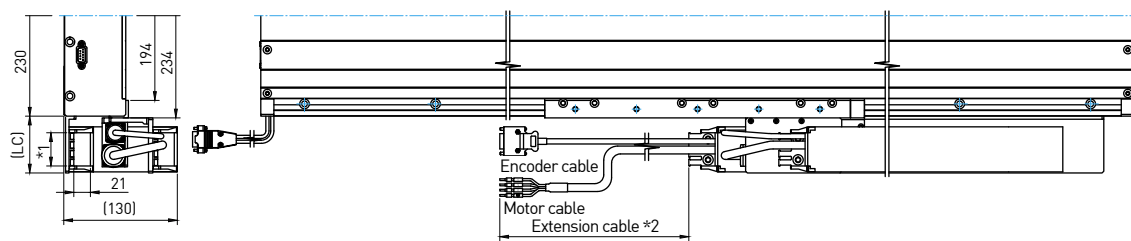

Table2-8 SA23

Stroke(mm)	N	LT	LA	LB	LC	LD	LC(cable chain)	
							V1,V2 ^{*3}	V3,V4 ^{*3}
100	4	600	65	-	100	270	65	95
200	4	700	75	-	150	250		
300	6	800	25	750	-	-		
400	6	900	75	750	-	-		
500	7	1000	50	900	-	-		
600	8	1100	25	1050	-	-		
700	8	1200	75	1050	-	-		
800	9	1300	50	1200	-	-		
900	10	1400	25	1350	-	-		
1000	10	1500	75	1350	-	-		

*1:Cable chain interior width is selected from ordering information.

*2:Extension cable length is selected from ordering information.

*3:Dimension LC is determined by cable chain interior width V1-V4 from ordering information.

SA31,SA32,SA33

Table2-9 SA31,32,33 stage specification

Specification	SA31	SA31L	SA32	SA32L	SA33	SA33L
Continuous force, F_c (N)	292	292	583	583	875	875
Peak force, F_p (N)	823	823	1646	1646	2469	2469
Stroke (mm)	100~1000(mm)					
Resolution	0.1 μ m / 1.0 μ m / Analog 1Vpp					
Repeatability (μ m) ^{*2}	Digital 1 μ m encoder / Analog encoder: \pm 1					
	Digital 0.1 μ m encoder: \pm 0.5					
Accuracy (μ m) ^{*2,3}	Digital 1 μ m encoder / Analog encoder: \pm 2					
	Digital 0.1 μ m encoder: \pm 1					
Horizontal straightness (μ m)	10 / 500 mm					
Vertical straightness (μ m)	20 / 500 mm					
Moving mass (kg)	7.5		10.5		14.5	
Loading capacity (kg)	40		50		60	

Force-Velocity Curve(DC bus = 325V)^{*4}

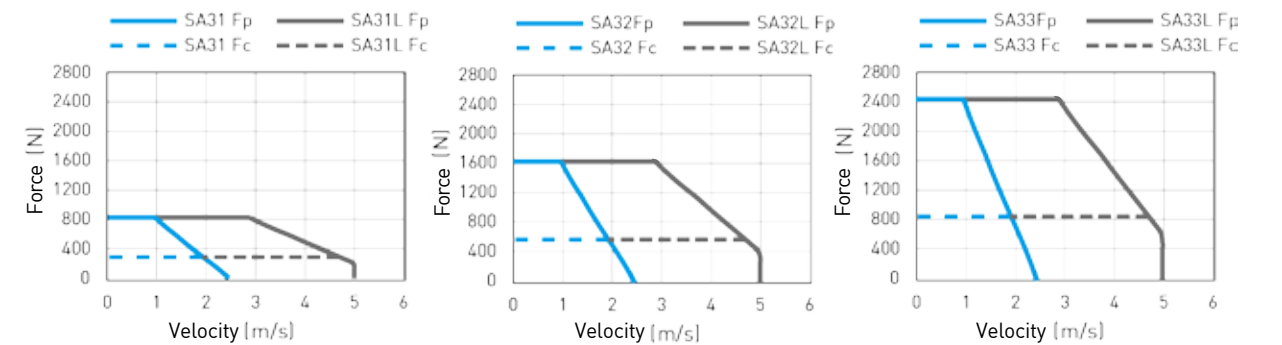

Force-Velocity Curve(DC bus = 600V)^{*4}

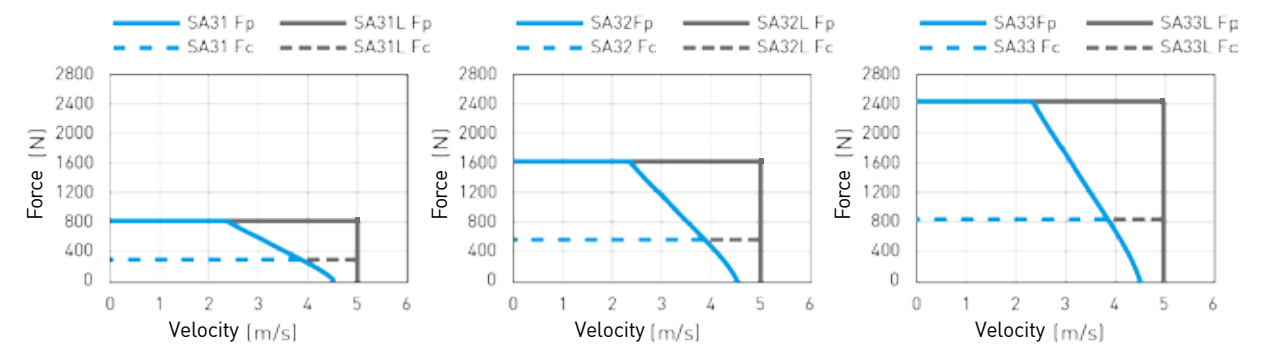

Acceleration-Payload Curve

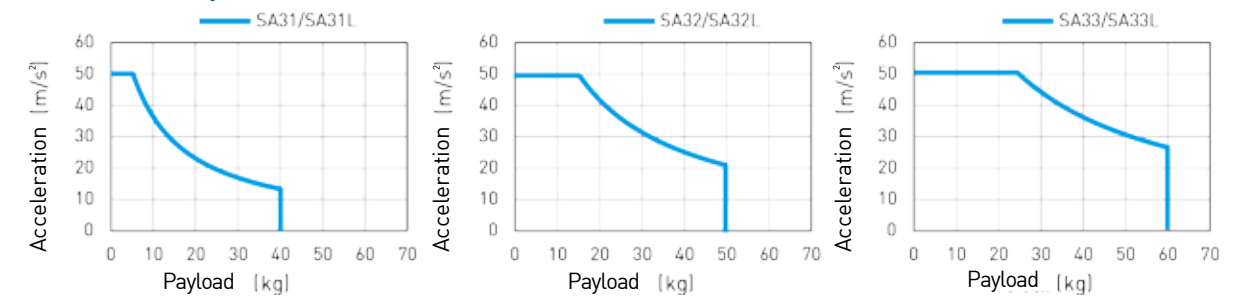

*1 : All values are measured on a granite table, all stage mounting holes are well fixed.

*2 : Values are measured according to HIWIN measuring standard.

*3 : After error compensation.

*4 : The Force-Velocity Curve is the characteristic curve of the motor. The actual velocity will change with stroke, payload and acceleration. Please refer to the Velocity-Stroke Curve or Appendix A : Motor Sizing.

*5 : All specifications above are standard, contact HIWIN for special request.

Velocity-Stroke Curve

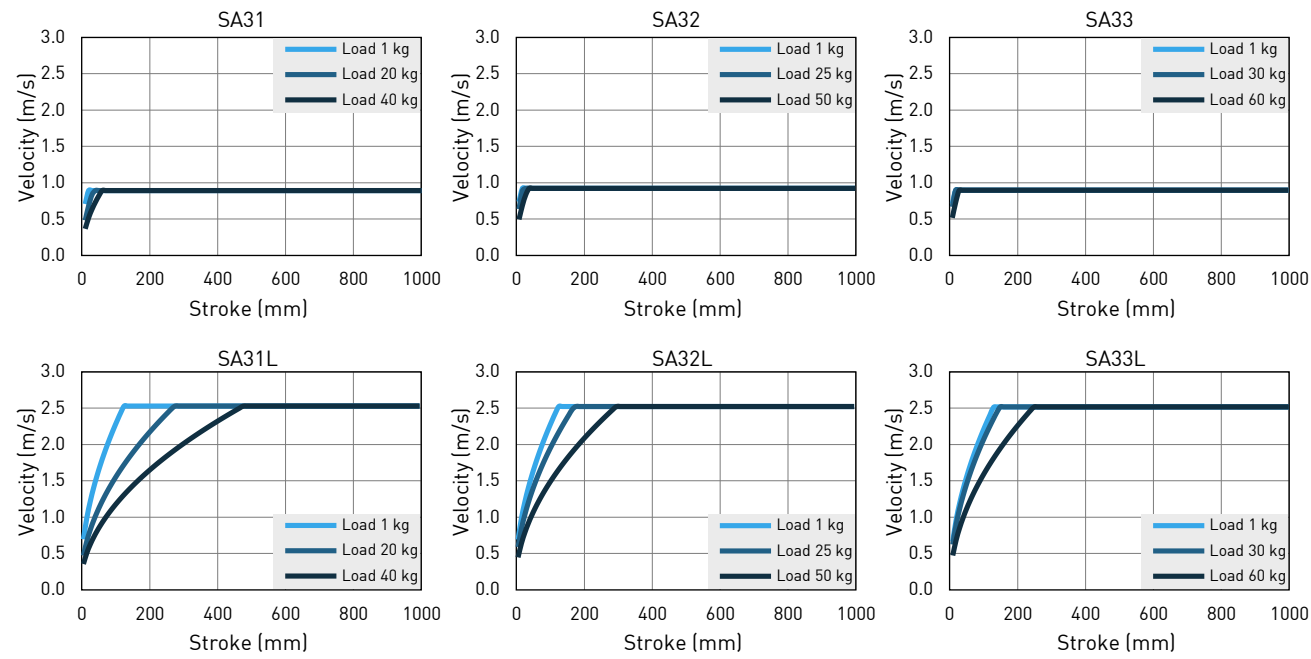

Cantilever Load Capability*2,3

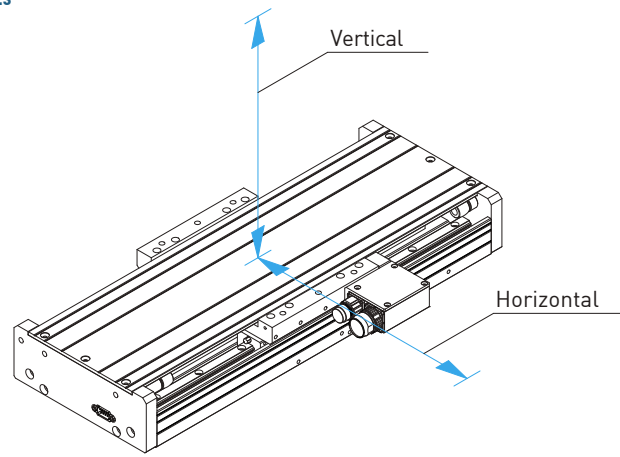

Vertical

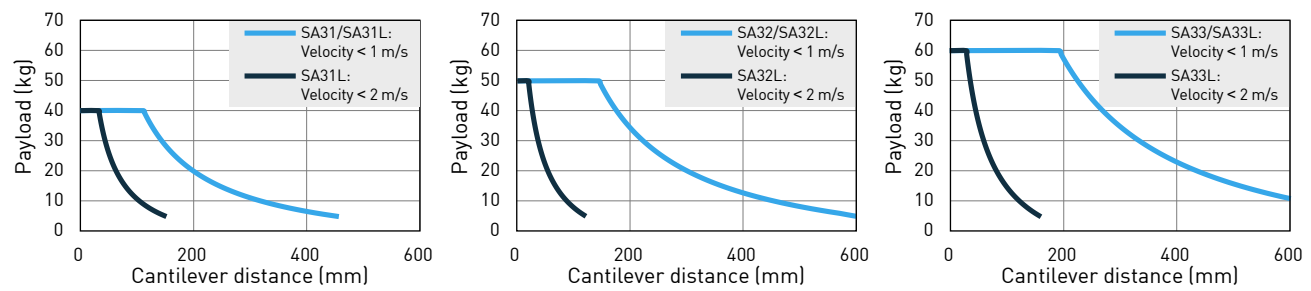

Horizontal

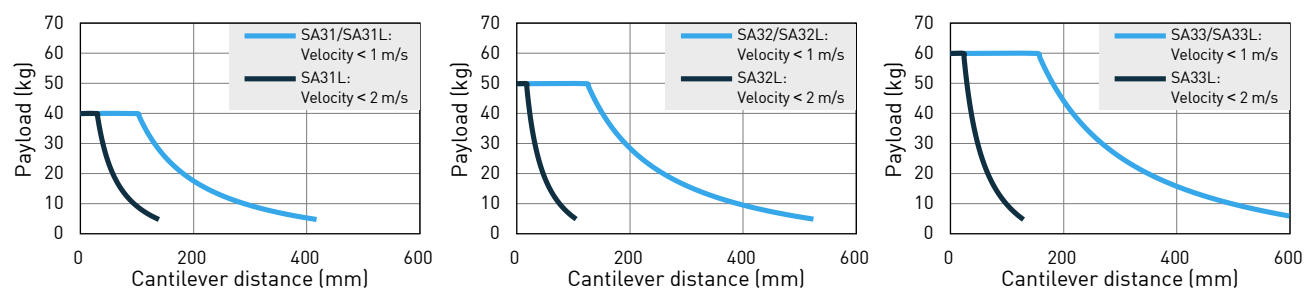

*1 : All values above are standard, contact HIWIN for special request.
*2 : Cantilever load capability due to different positioning stage, application rated life also vary.
*3 : The main reason for lifetime derives from linear guideway. For more details, please refer to HIWIN linear guideway catalog.

SA31 Linear motor stage dimensions

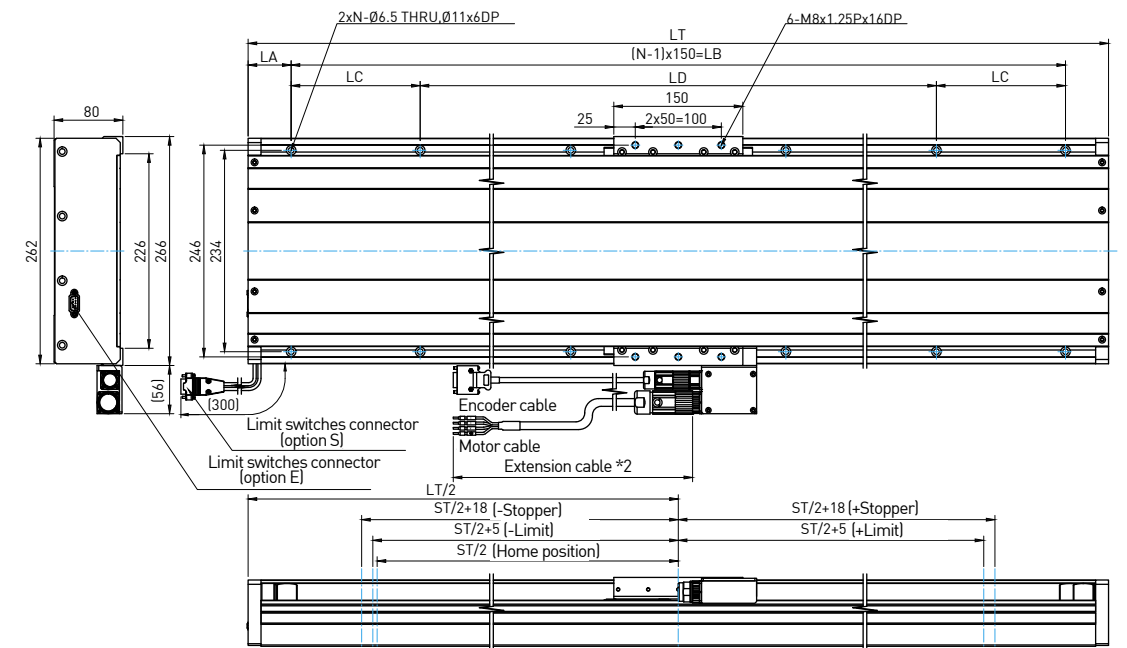

Linear motor stage with horizontal chain

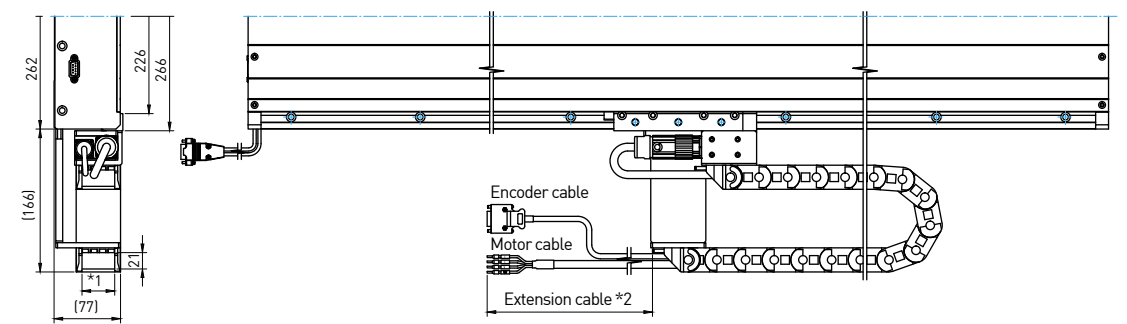

Linear motor stage with vertical chain

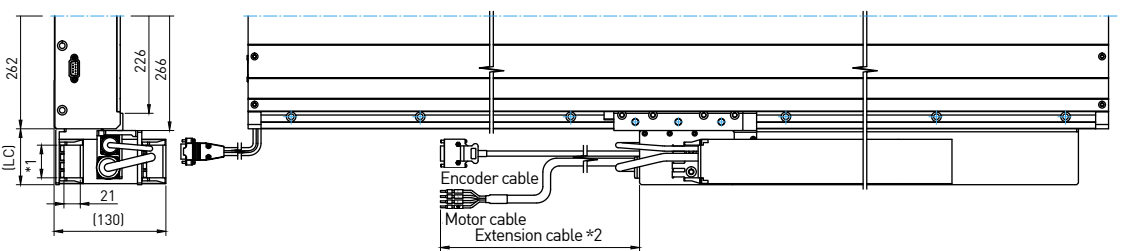
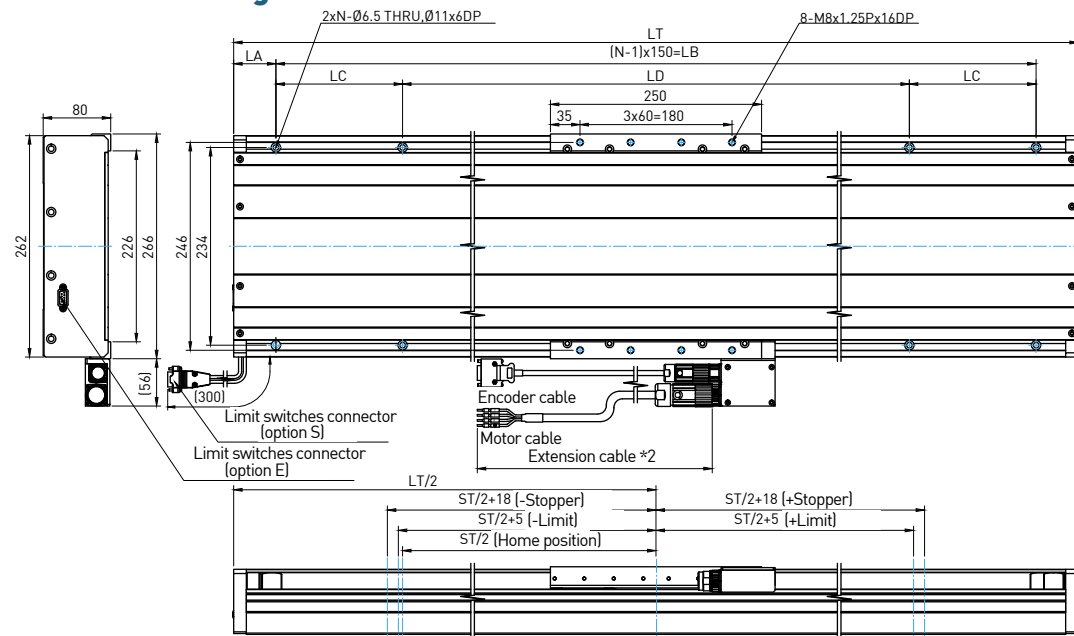

Table2-10 SA31

Stroke(mm)	N	LT	LA	LB	LC	LD	LC(cable chain)	
							V1,V2*3	V3,V4*3
100	4	400	25	-	100	150	65	95
200	4	500	25	-	100	250		
300	4	600	65	-	100	270		
400	5	700	75	-	150	250		
500	6	800	25	750	-	-		
600	6	900	75	750	-	-		
700	7	1000	50	900	-	-		
800	8	1100	25	1050	-	-		
900	8	1200	75	1050	-	-		
1000	9	1300	50	1200	-	-		

*1:Cable chain interior width is selected from ordering information.
*2:Extension cable length is selected from ordering information.
*3:Dimension LC is determined by cable chain interior width V1-V4 from ordering information.

SA32 Linear motor stage dimensions



SA33 Linear motor stage dimensions

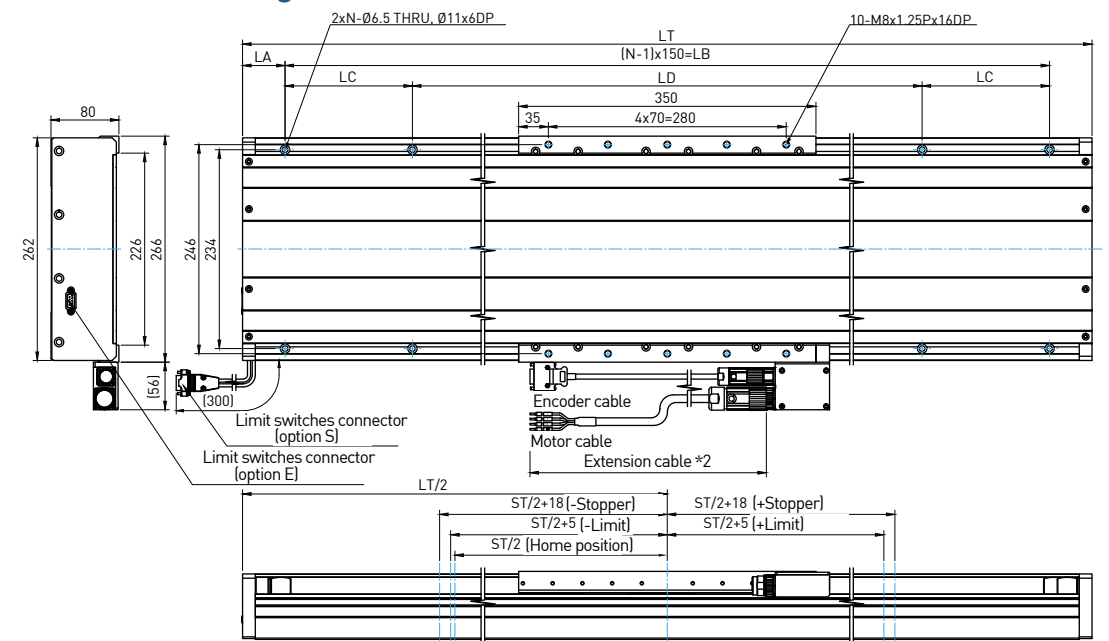

Linear motor stage with horizontal chain

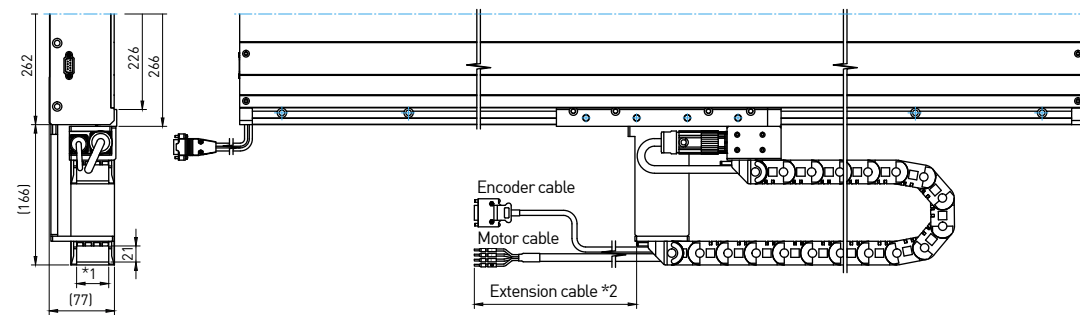

Linear motor stage with horizontal chain

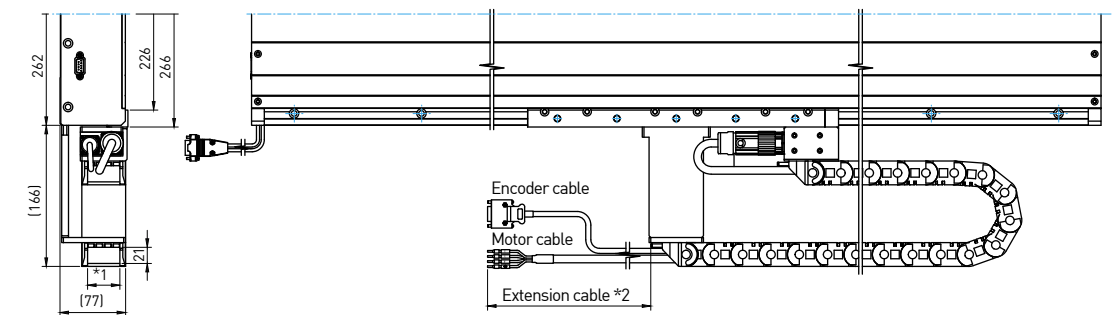

Linear motor stage with vertical chain

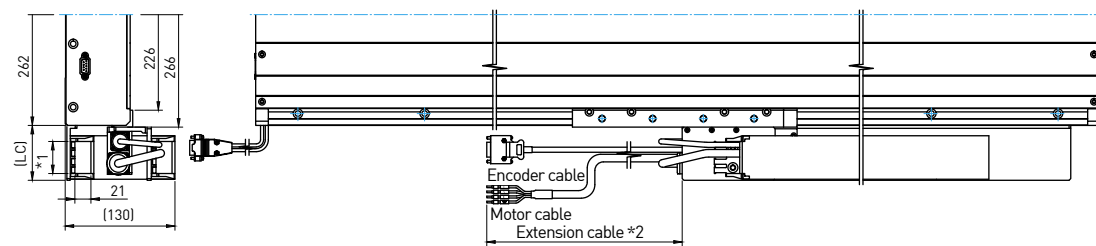

Linear motor stage with vertical chain

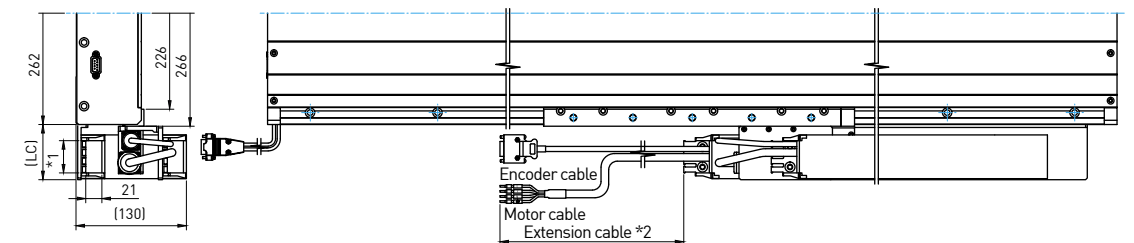

Table2-11 SA32

Stroke(mm)	N	LT	LA	LB	LC	LD	LC(cable chain)	
							V1,V2 ^{*3}	V3,V4 ^{*3}
100	4	500	25	-	100	250	65	95
200	4	600	65	-	100	270		
300	4	700	75	-	150	250		
400	6	800	25	750	-	-		
500	6	900	75	750	-	-		
600	7	1000	50	900	-	-		
700	8	1100	25	1050	-	-		
800	8	1200	75	1050	-	-		
900	9	1300	50	1200	-	-		
1000	10	1400	25	1350	-	-		

*1:Cable chain interior width is selected from ordering information.

*2:Extension cable length is selected from ordering information.

*3:Dimension LC is determined by cable chain interior width V1-V4 from ordering information.

Table2-12 SA33

Stroke(mm)	N	LT	LA	LB	LC	LD	LC(cable chain)	
							V1,V2 ^{*3}	V3,V4 ^{*3}
100	4	600	65	-	100	270	65	95
200	4	700	75	-	150	250		
300	6	800	25	750	-	-		
400	6	900	75	750	-	-		
500	7	1000	50	900	-	-		
600	8	1100	25	1050	-	-		
700	8	1200	75	1050	-	-		
800	9	1300	50	1200	-	-		
900	10	1400	25	1350	-	-		
1000	10	1500	75	1350	-	-		

*1:Cable chain interior width is selected from ordering information.

*2:Extension cable length is selected from ordering information.

*3:Dimension LC is determined by cable chain interior width V1-V4 from ordering information.

2.3 LMC high-precision, high-speed stability

Linear motor LMC stages are equipped with coreless motor(s) and well suited for applications that require precision positioning and constant velocity scanning motion.

- Linear motor direct drive, enabling ultra-precise movement
- Stroke range up to 4m
- Superior speed control characteristic
- Low cost, small size, high performance
- Suitable for clean rooms



2.3.1 Linear single axis

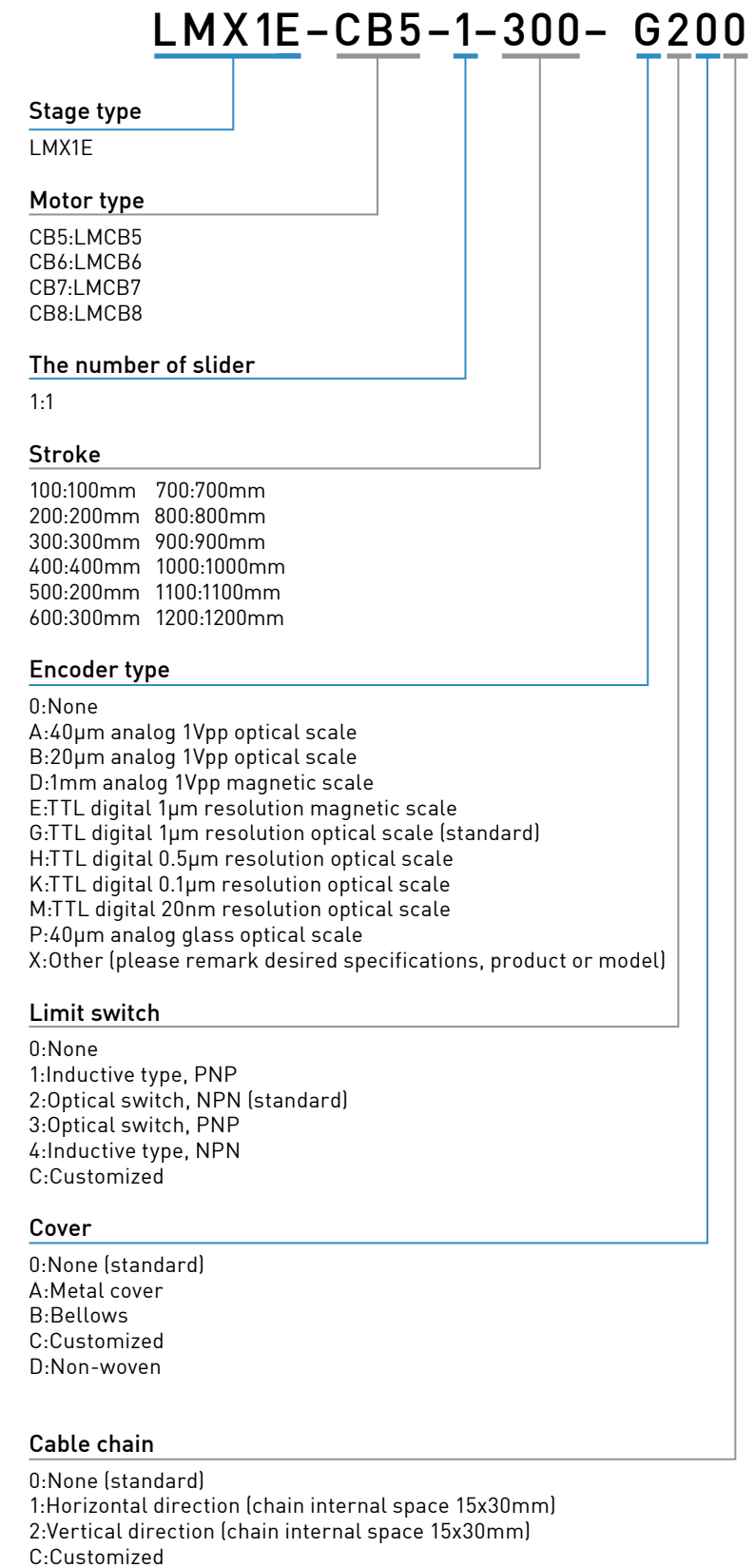

Note : Contact HIWIN for customized specification.

Table2-13 LMCB5,6,7,8 stage specification

Specification	CB5	CB6	CB7	CB8
Continuous force, F_c (N)	91	109	128	145
Peak force, F_p (N)	364	436	512	580
Stroke (mm)	100-1200			
Resolution	1.0 μ m			
Repeatability (μ m) *2	Stroke 100~1000 mm: \pm 1			
	Stroke 1100 / 1200 mm: \pm 2			
Accuracy (μ m) *2,3	Stroke 100~1000 mm: \pm 3			
	Stroke 1100 / 1200 mm: \pm 8			
Horizontal straightness (μ m)	10 / 500 mm			
Vertical straightness (μ m)	20 / 500 mm			
Moving mass (kg)	No cover: 2.1	No cover: 3.1	3.8	4.7
	With cover: 2.3	With cover: 3.3		

Force-Velocity Curve (DC bus = 325V) *4

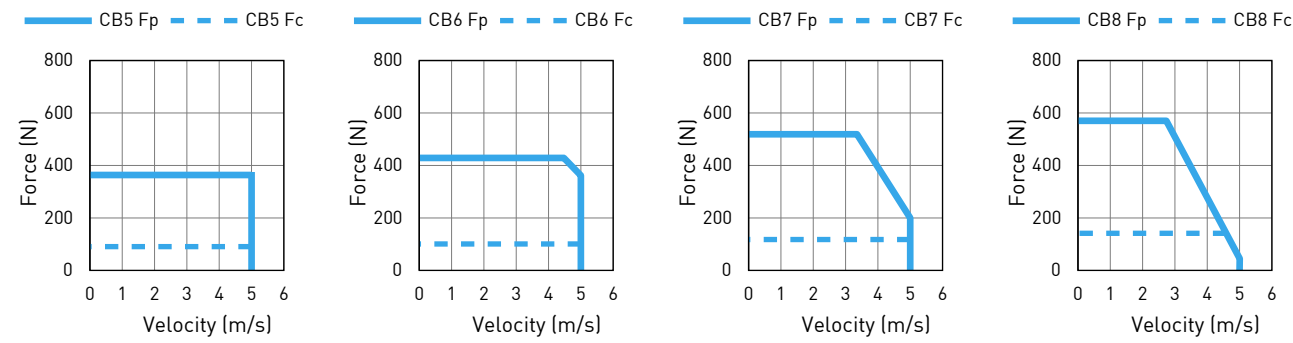

Acceleration-Payload Curve

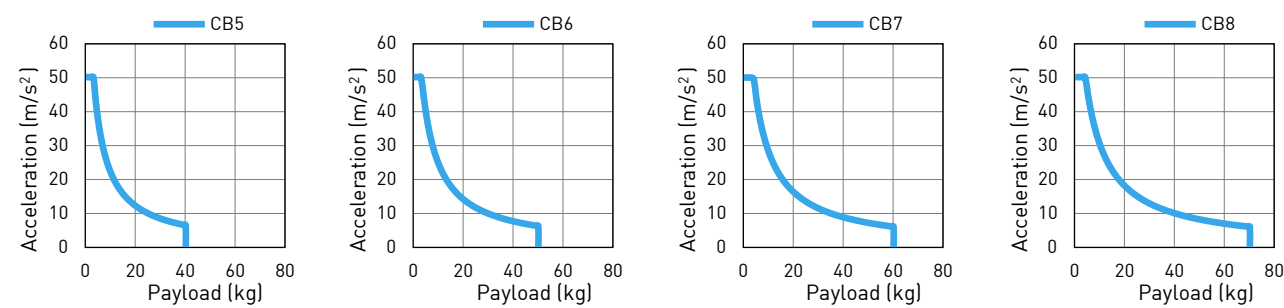

*1 : All values are measured on a granite table, all stage mounting holes are well fixed.
 *2 : Values are measured according to HIWIN measuring standard.
 *3 : After error compensation.
 *4 : The Force-Velocity Curve is the characteristic curve of the motor. The actual velocity will change with stroke, payload and acceleration. Please refer to the Velocity-Stroke Curve or Appendix A : Motor Sizing.
 *5 : All specifications above are standard, contact HIWIN for special request.

Velocity-Stroke Curve

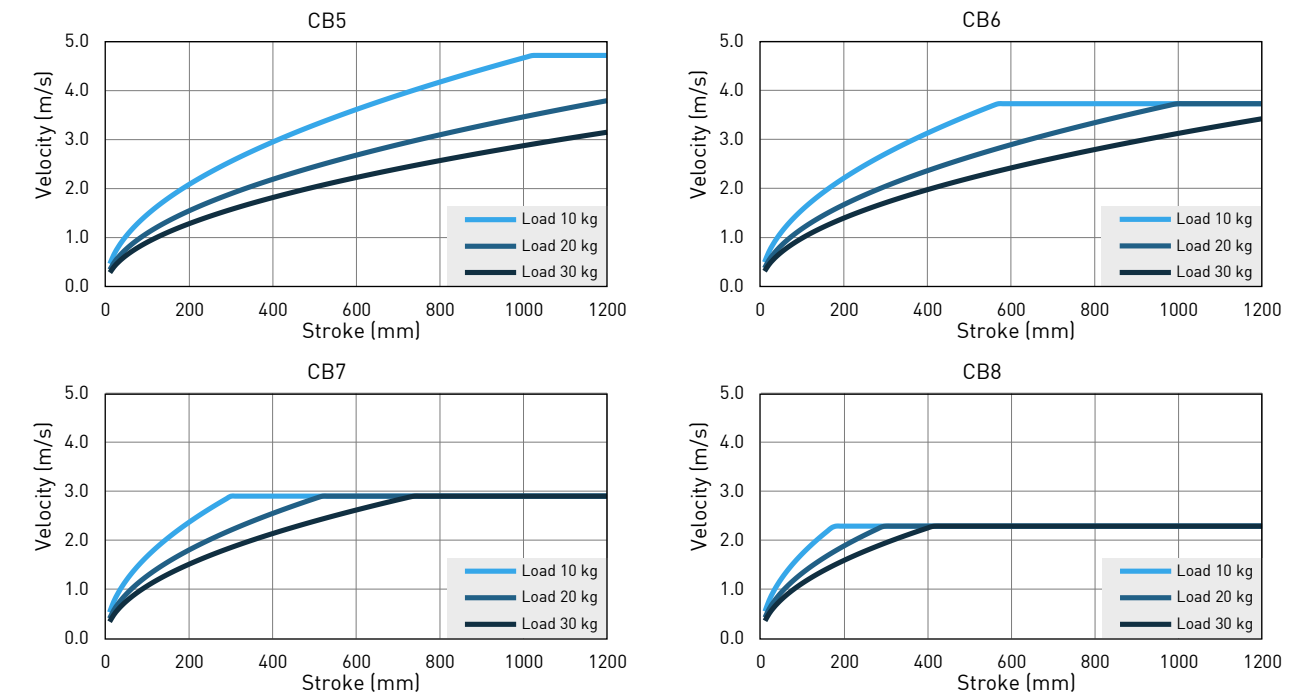

Cantilever Load Capability *2,3

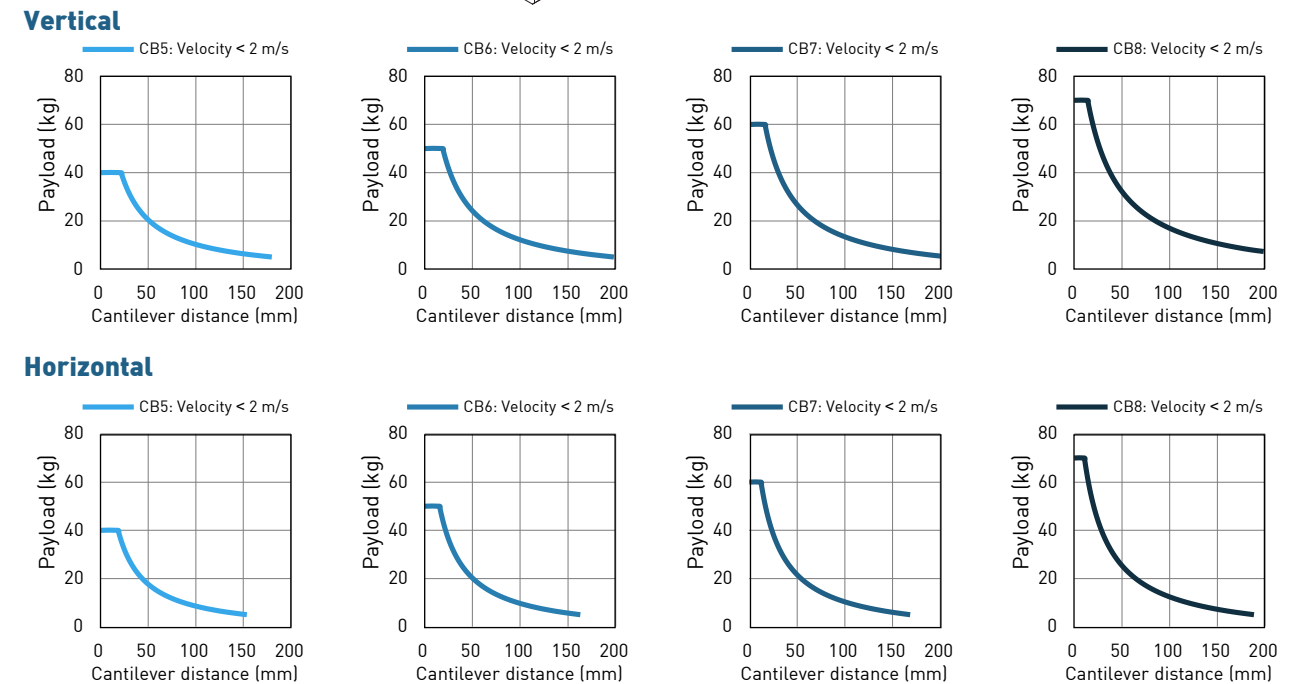
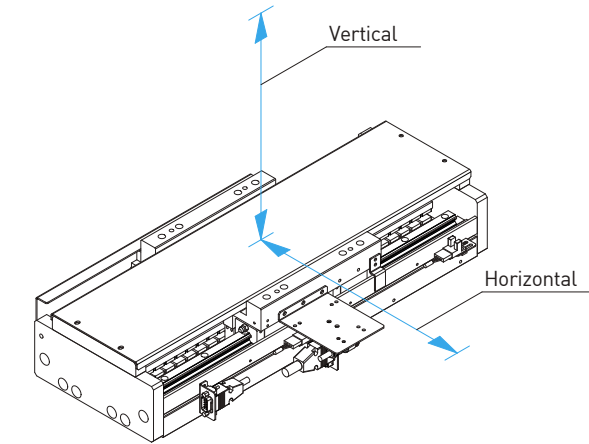

*1 : All values above are standard, contact HIWIN for special request.
 *2 : Cantilever load capability due to different positioning stage, application rated life also vary.
 *3 : The main reason for lifetime derives from linear guideway. For more details, please refer to HIWIN linear guideway catalog.

2.2.3 LMC Series Stage

LMCB5

Table2-14 Without/with cover linear motor stage specifications

Stroke (mm)	L (mm)	L1 (mm)	N	Mass (kg)	H (mm)
100	400	35	1*1	18/19	95
200	500	85	2	22/23	95
300	600	60	3	26/27	95
400	700	35	4	30/31	95
500	800	85	4	34/35	95
600	900	60	5	38/39	95
700	1000	35	6	42/43	95
800	1100	85	6	46/47	95
900	1200	60	7	50/51	95
1000	1300	35	8	54/55	95
1100	1400	85	8	58/59	105
1200	1500	60	9	62/63	105

*1 : When stroke is 100mm, the mounting holes spacing is 300mm.
*2: Absolute accuracy is after error mapping(with HIWIN drive).

Without cover

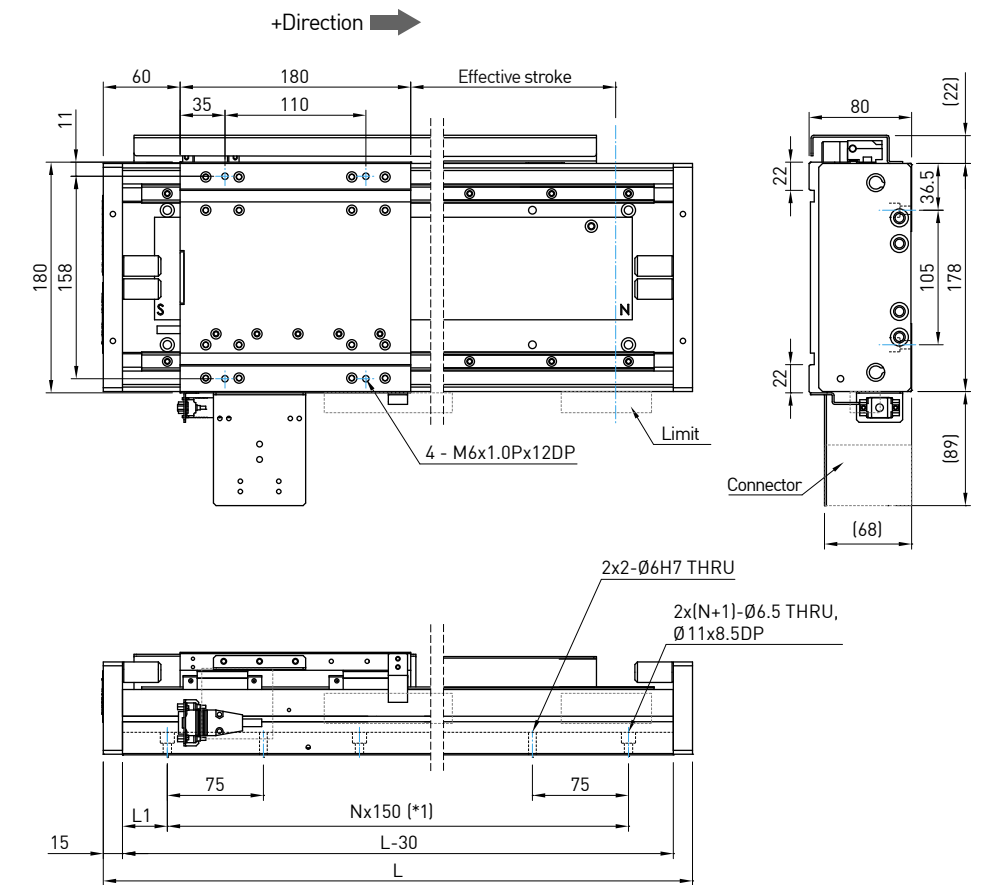

With cover

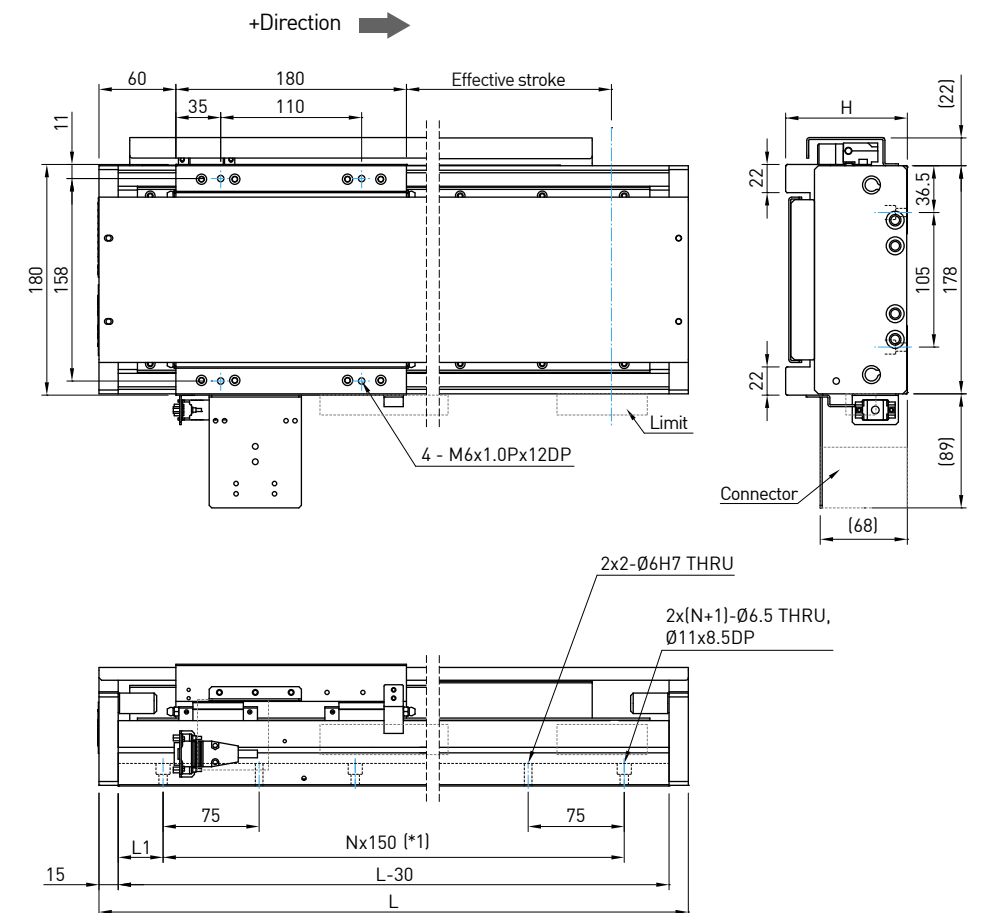

LMCB6

Table2-15 Without/with cover linear motor stage specifications

Stroke (mm)	L (mm)	L1 (mm)	N	Mass (kg)	H (mm)
100	430	50	1*1	19/20	95
200	530	25	3	23/24	95
300	630	75	3	27/28	95
400	730	50	4	31/32	95
500	830	25	5	35/36	95
600	930	75	5	39/40	95
700	1030	50	6	43/44	95
800	1130	25	7	47/48	95
900	1230	75	7	51/52	95
1000	1330	50	8	55/56	95
1100	1430	25	9	59/60	105
1200	1530	75	9	63/64	105

*1: When stroke is 100mm, the mounting holes spacing is 300mm.
*2: Absolute accuracy is after error mapping(with HIWIN drive).

Without cover

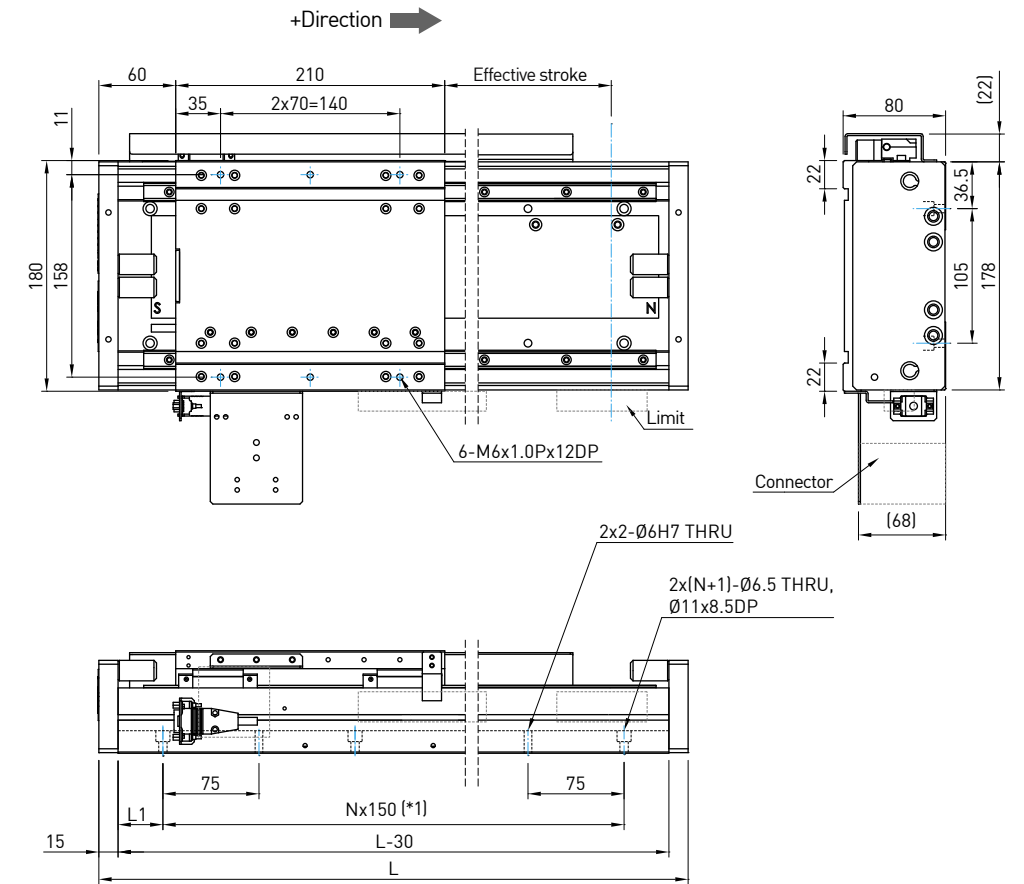

With cover

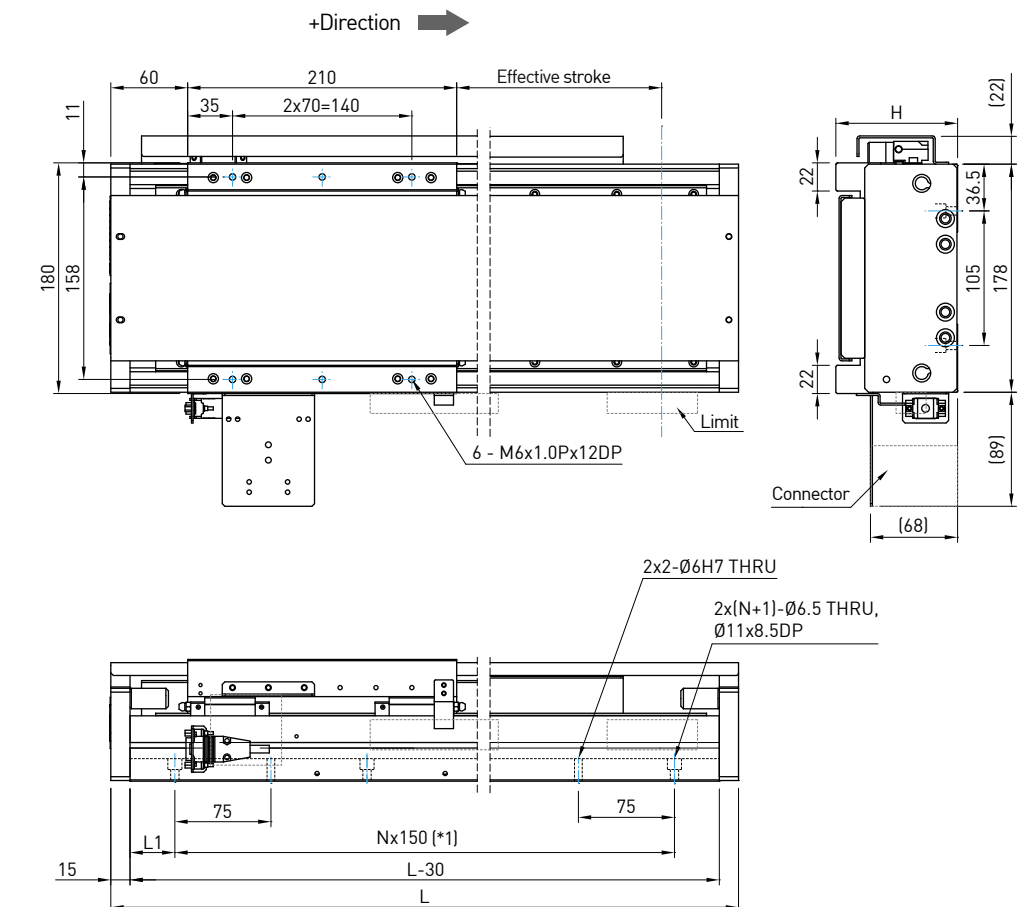

LMCB7

Table2-16 Without/with cover linear motor stage specifications

Stroke (mm)	L (mm)	L1 (mm)	N	Mass (kg)	H (mm)
100	460	65	1 ^{*1}	20/21	95
200	560	40	3	24/25	95
300	660	90	3	28/29	95
400	760	65	4	32/33	95
500	860	40	5	36/37	95
600	960	90	5	40/41	95
700	1060	65	6	44/45	95
800	1160	40	7	48/49	95
900	1260	90	7	52/53	95
1000	1360	65	8	56/57	95
1100	1460	40	9	60/61	105
1200	1560	90	9	64/65	105

*1 : When stroke is 100mm, the mounting holes spacing is 300mm.
*2: Absolute accuracy is after error mapping(with HIWIN drive).

Without cover

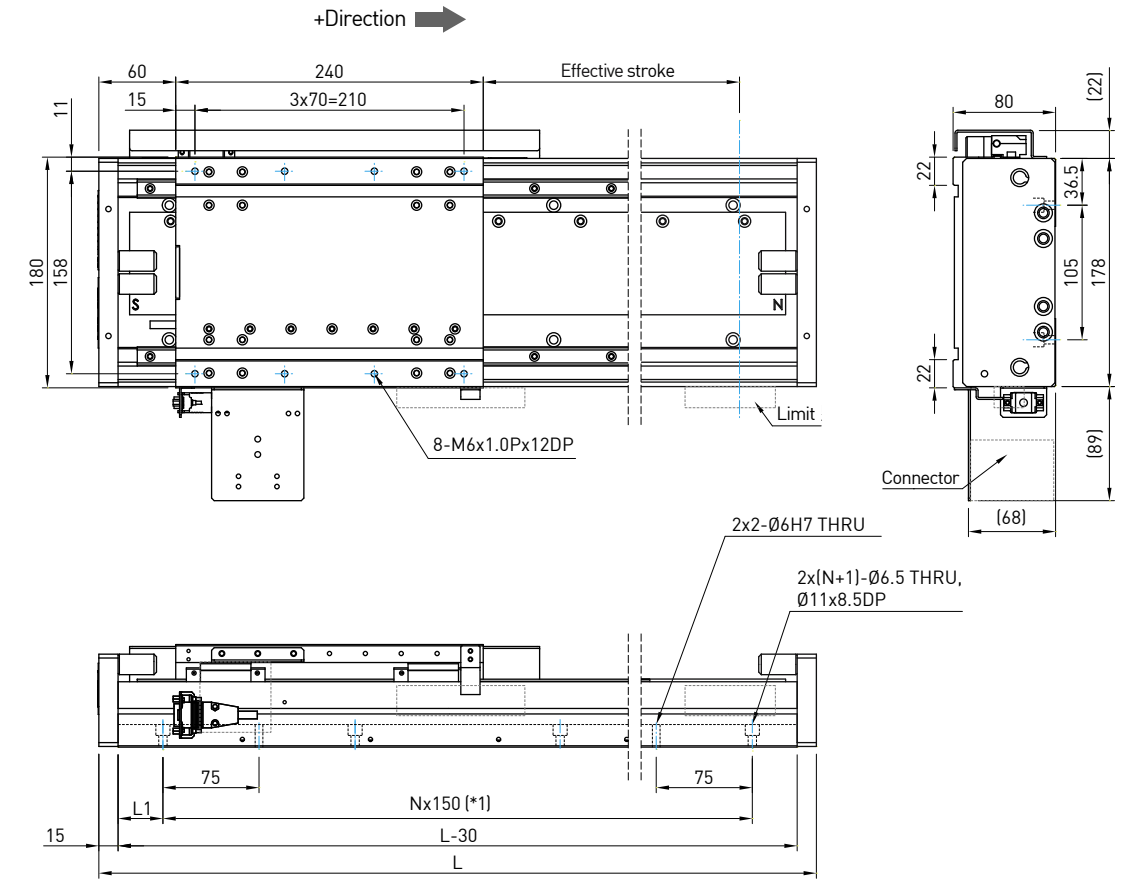

With cover

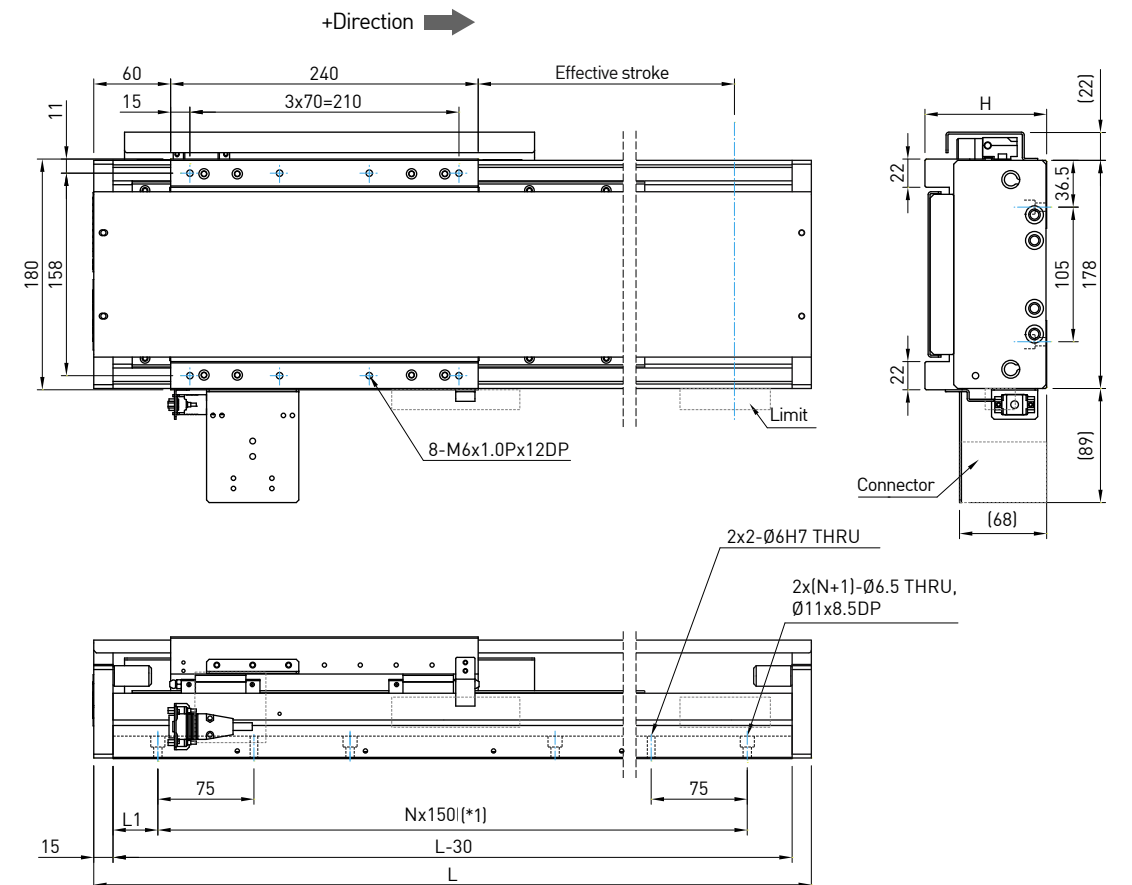

LMCB8

Table2-17 Without/with cover linear motor stage specifications

Stroke (mm)	L (mm)	L1 (mm)	N	Mass (kg)	H (mm)
100	500	85	1 ^{*1}	21/22	95
200	600	60	3	25/26	95
300	700	35	4	29/30	95
400	800	85	4	33/34	95
500	900	60	5	37/38	95
600	1000	35	6	41/42	95
700	1100	85	6	45/46	95
800	1200	60	7	49/50	95
900	1300	35	8	53/54	95
1000	1400	85	8	57/58	95
1100	1500	60	9	61/62	105
1200	1600	35	10	65/66	105

*1 : When stroke is 100mm, the mounting holes spacing is 300mm.
*2: Absolute accuracy is after error mapping(with HIWIN drive).

Without cover

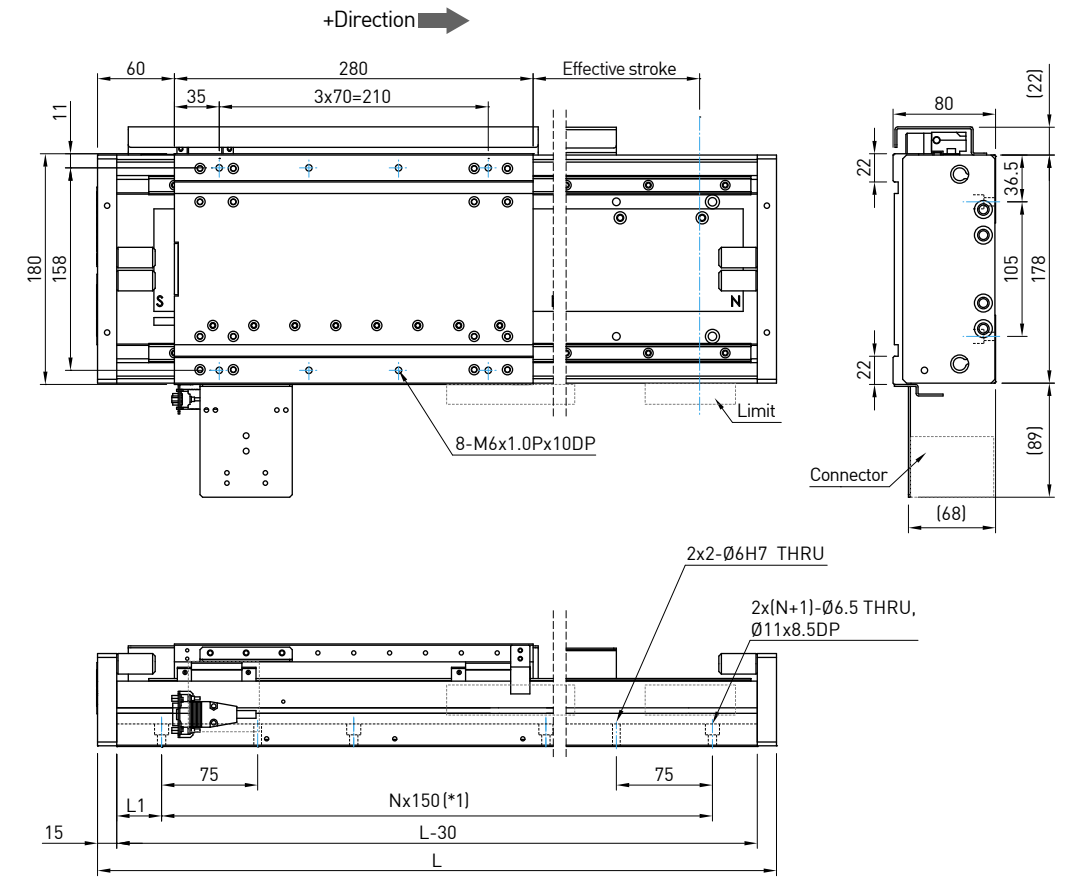

With cover

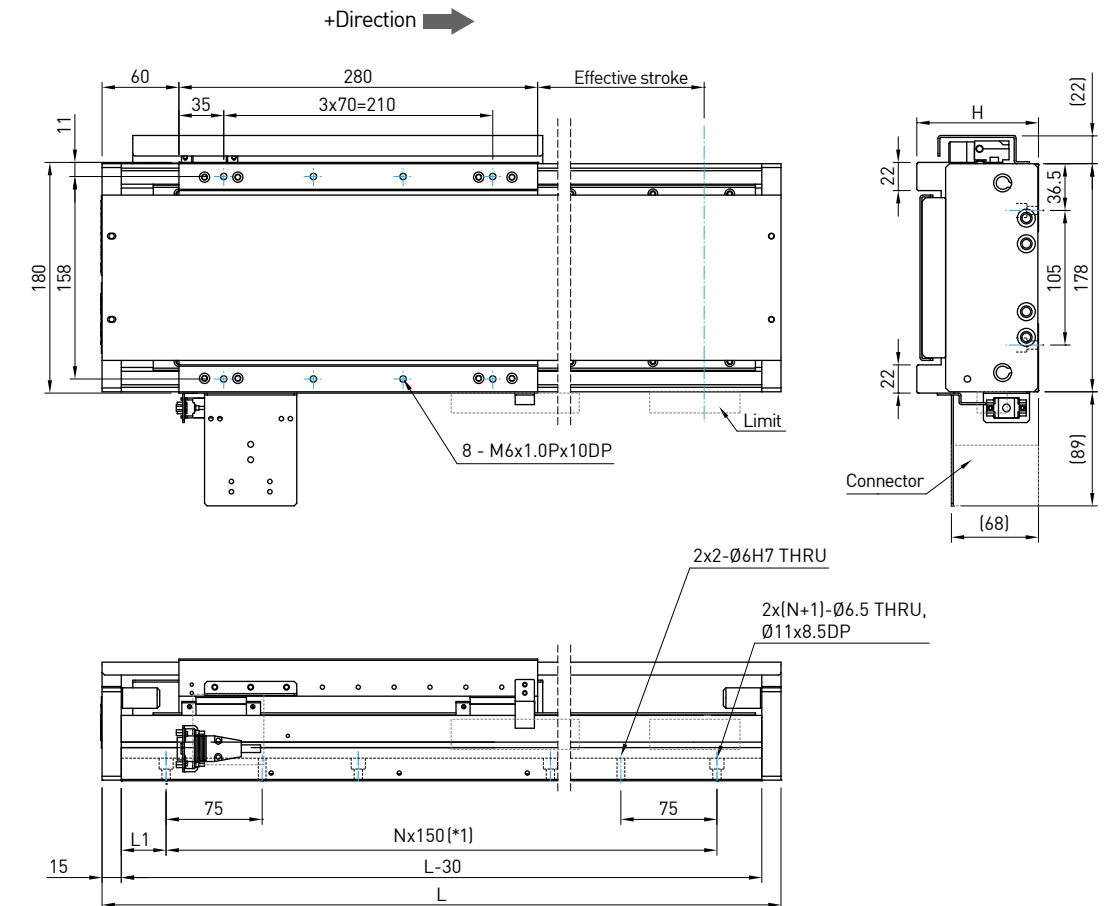

2.4 LMT light weight, high acceleration/deceleration

Shaft motor series with LMT ironless motors are suitable for inspection, scan and semiconductor industry. It can also be assembled into X-Y stage; position feedback applies incremental analog or digital optical scale and magnetic scale as position feedback are selectable.

- Lightweight
- No cogging
- Max. acceleration 50m/s², max. velocity 5m/s
- High acceleration and deceleration characteristics

2.4.1 Linear single axis

LMX1E-TA2-1-300-G200

Stage type
LMX1E

Motor type
TA2:LMTA2 TB3:LMTB3 TC4:LMTC4
TA3:LMTA3 TB4:LMTB4
TA4:LMTA4 TC2:LMTC2
TB2:LMTB2 TC3:LMTC3

The number of slider
1:1

Stroke
388:388mm 1156:1156mm
516:516mm 1412:1412mm
644:644mm 1668:1668mm
722:722mm 1924:1924mm
900:900mm 2180:2180mm

Encoder type
0:None
A:40μm analog 1Vpp optical scale
B:20μm analog 1Vpp optical scale
D:1mm analog 1Vpp magnetic scale
E:TTL digital 1μm resolution magnetic scale
G:TTL digital 1μm resolution optical scale (standard)
H:TTL digital 0.5μm resolution optical scale
K:TTL digital 0.1μm resolution optical scale
M:TTL digital 20nm resolution optical scale
P:40μm analog glass optical scale
X:Other (please remark desired specifications, product or model)

Limit switch
0:None
1:Inductive type, PNP
2:Optical switch, NPN (standard)
3:Optical switch, PNP
4:Inductive type, NPN
C:Customized

Cover
0:None (standard)
A:Metal cover
B:Bellows
C:Customized
D:Non-woven

Cable chain
0:None (standard)
1:Horizontal direction (chain internal space 15x30mm)
2:Vertical direction (chain internal space 15x30mm)
C:Customized

Note : Contact HIWIN for customized specification.

2.4.2 LMTA2 Shaft motor stage

Table2-18 LMTA2,3,4 stage specification

Specification	TA2	TA3	TA4
Continuous force, F _c (N)	27	42	55
Peak force, F _p (N)	108	168	220
Stroke (mm)	100-1000		
Resolution	1.0μm		
Repeatability (μm) *2	±1		
Accuracy (μm) *2,3	±3		
Horizontal straightness (μm)	10 / 500 mm		
Vertical straightness (μm)	20 / 500 mm		
Moving mass (kg)	1.4	2.1	2.3

Force-Velocity Curve (DC bus = 325V)*4

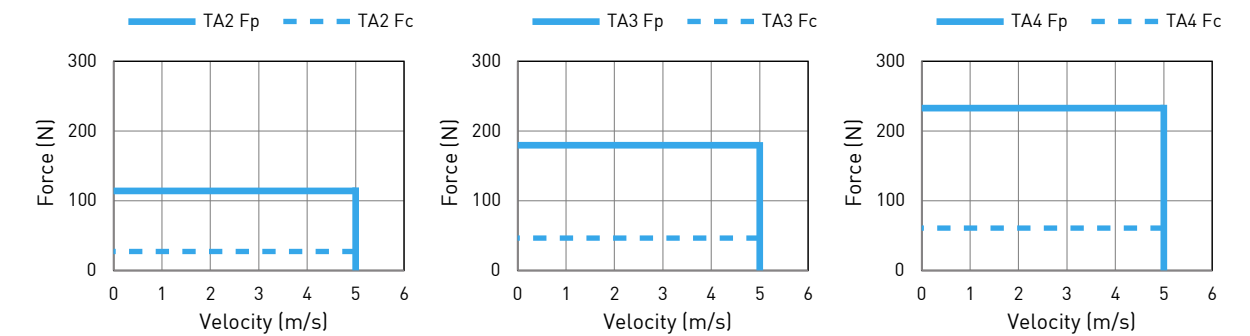

Acceleration-Payload Curve

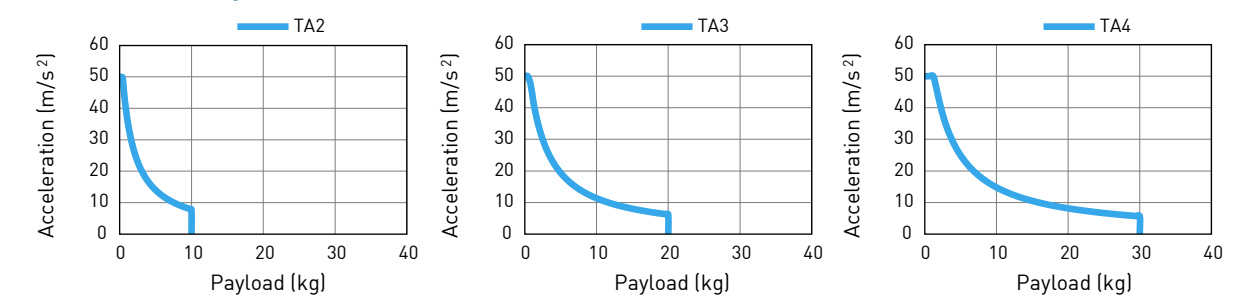

*1 : All values are measured on a granite table, all stage mounting holes are well fixed.

*2 : Values are measured according to HIWIN measuring standard.

*3 : After error compensation.

*4 : The Force-Velocity Curve is the characteristic curve of the motor. The actual velocity will change with stroke, payload and acceleration. Please refer to the Velocity-Stroke Curve or Appendix A : Motor Sizing.

*5 : All specifications above are standard, contact HIWIN for special request.

Velocity-Stroke Curve

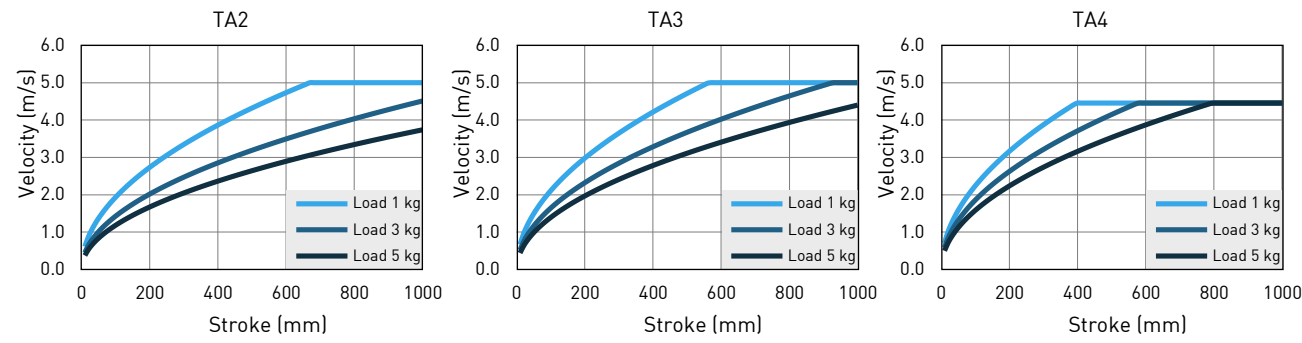

Cantilever Load Capacity*2,3

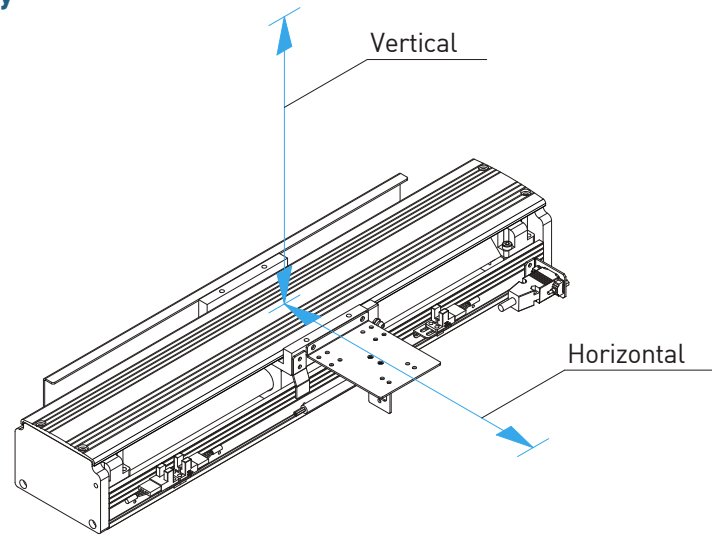

Vertical

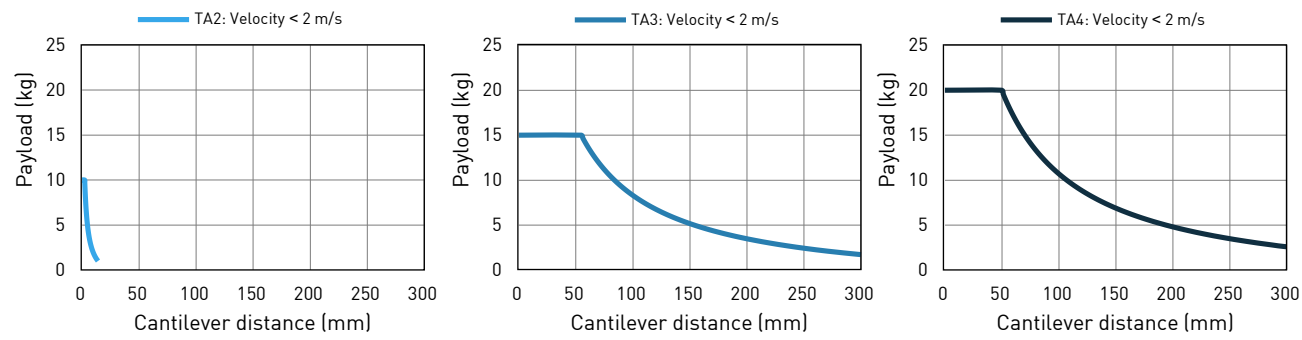

Horizontal

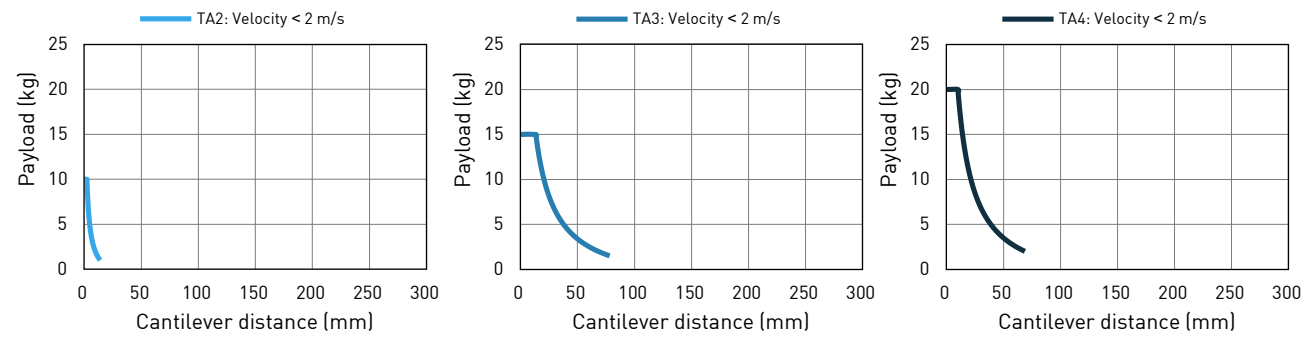

*1 : All values above are standard, contact HIWIN for special request.

*2 : Cantilever load capability due to different positioning stage, application rated life also vary.

*3 : The main reason for lifetime derives from linear guideway. For more details, please refer to HIWIN linear guideway catalog.

Table2-19 LMTA2 Shaft motor stage specifications

Stroke (mm)	L (mm)	L1 (mm)	L2 (mm)	N	Mass (kg)
100	304	67	54.5	1	5
200	404	42	54.5	2	6
300	534	32	69.5	3	6.9
400	634	82	69.5	3	7.9
500	734	57	69.5	4	8.8
600	834	32	69.5	5	9.8
700	974	27	89.5	6	11.2
800	1074	77	89.5	6	12.1
900	1174	52	89.5	7	13.1
1000	1274	27	89.5	8	14

* Absolute accuracy is after error mapping (with HIWIN drive).

Dimension

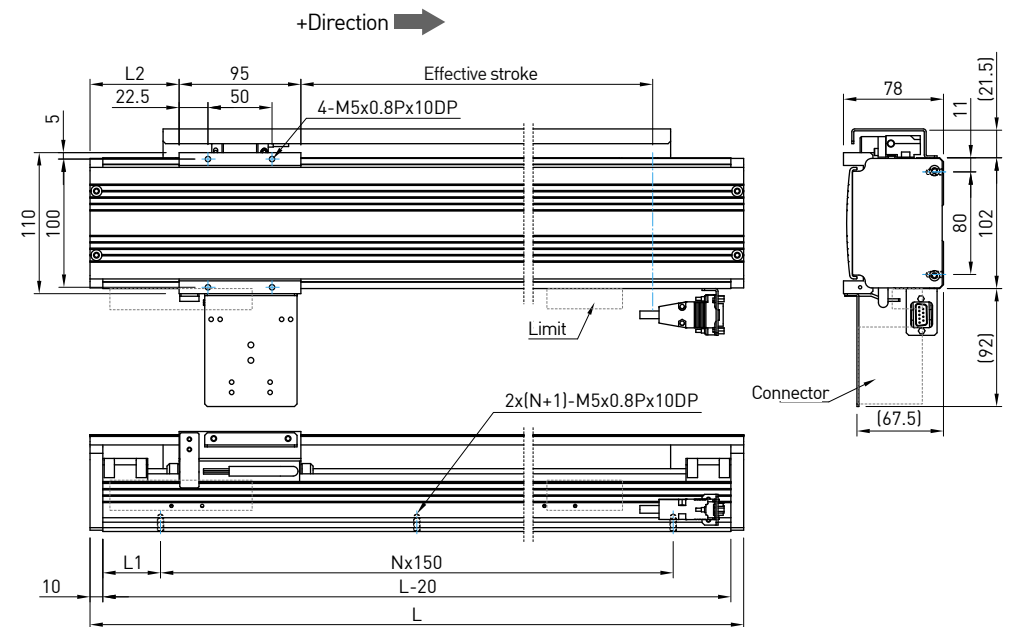

Table2-20 LMTA3 Shaft type linear motor stage specifications

Stroke (mm)	L (mm)	L1 (mm)	L2 (mm)	N	Mass (kg)
100	340	85	55	1	6.3
200	440	60	55	2	7.4
300	570	50	70	3	8.5
400	670	25	70	4	9.6
500	770	75	70	4	10.8
600	870	50	70	5	11.9
700	1010	45	90	6	13.5
800	1110	20	90	7	14.6
900	1210	70	90	7	15.8
1000	1310	45	90	8	16.9

* Absolute accuracy is after error mapping (with HIWIN drive).

Table2-21 LMTA4 Shaft type linear motor stage specifications

Stroke (mm)	L (mm)	L1 (mm)	L2 (mm)	N	Mass (kg)
100	376	28	53	2	7.0
200	476	78	53	2	8.1
300	606	68	68	3	9.2
400	706	43	68	4	10.4
500	806	18	68	5	11.5
600	906	68	68	5	12.6
700	1046	63	88	6	14.2
800	1146	38	88	7	15.3
900	1246	13	88	8	16.5
1000	1346	63	88	8	17.6

* Absolute accuracy is after error mapping (with HIWIN drive).

■ Dimension

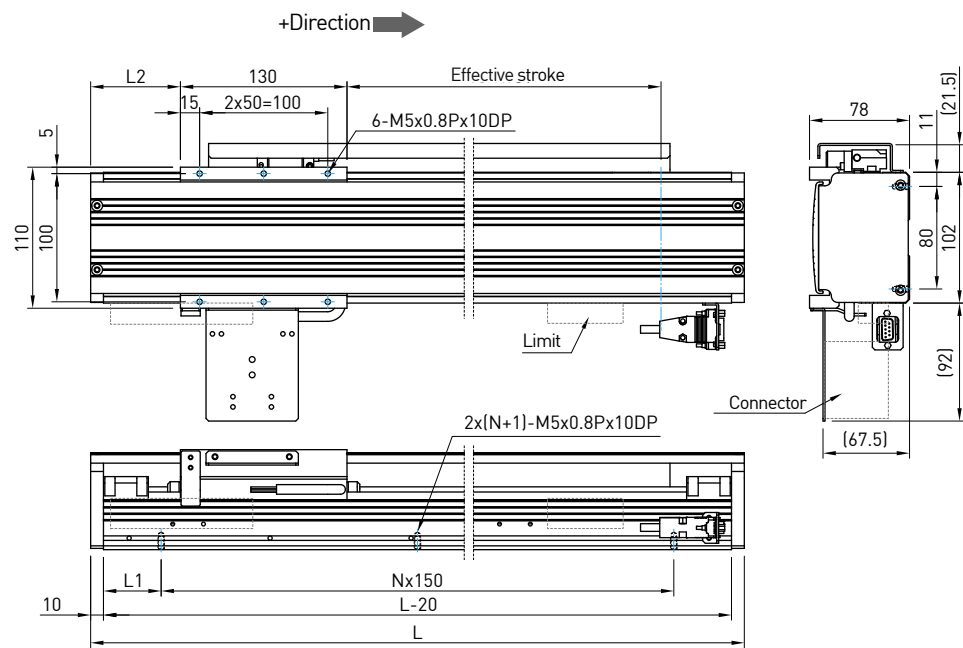

■ Dimension

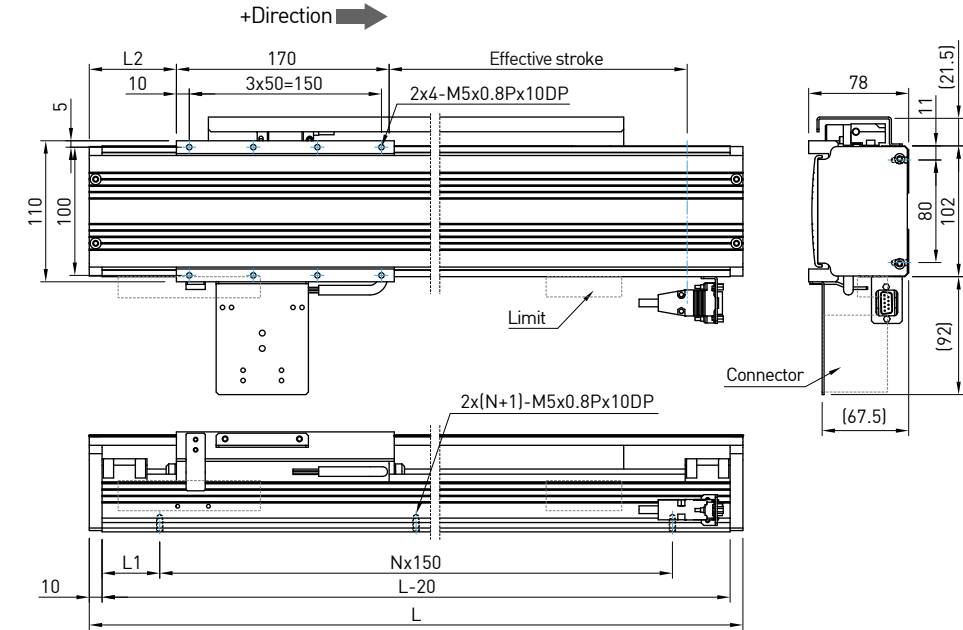

2.4.3 LMTB2 Shaft motor stage

Specification	TB2	TB3	TB4
Continuous force, F_c (N)	48	72	96
Peak force, F_p (N)	192	288	384
Stroke (mm)		100-1000	
Resolution		1.0 μ m	
Repeatability (μ m) *2		± 1	
Accuracy (μ m) *2,3		± 3	
Horizontal straightness (μ m)		10 / 500 mm	
Vertical straightness (μ m)		20 / 500 mm	
Moving mass (kg)	2.1	2.7	3.6

Force-Velocity Curve (DC bus = 325V) *4

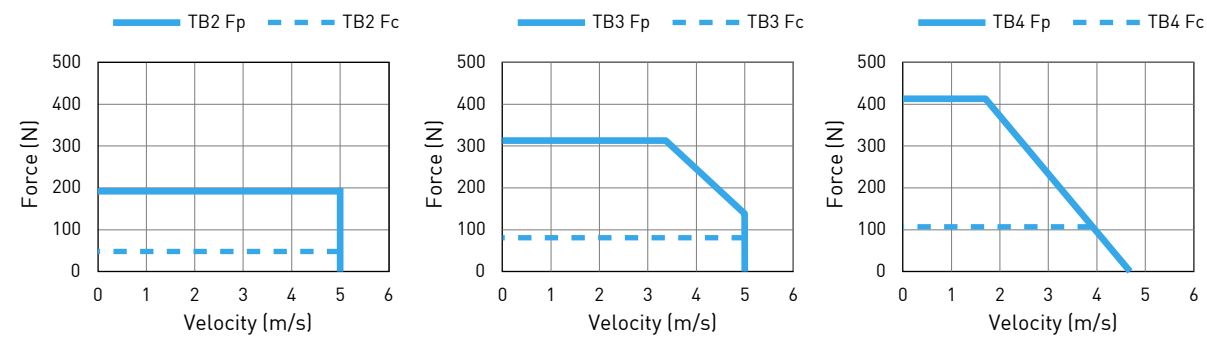

Acceleration-Payload Curve

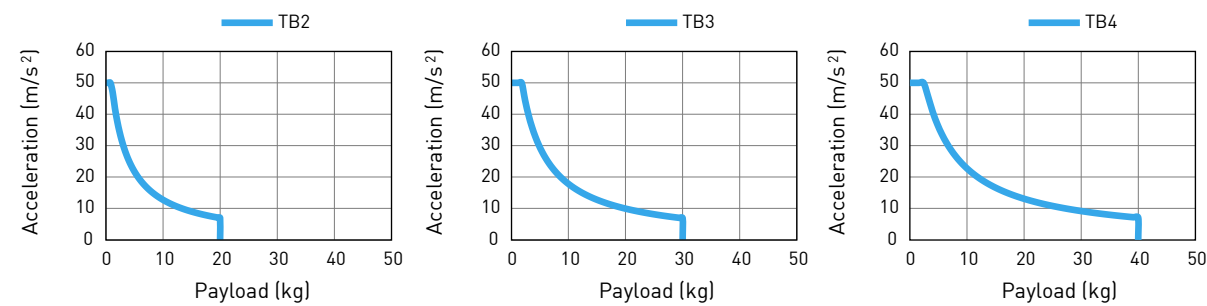

*1 : All values are measured on a granite table, all stage mounting holes are well fixed.

*2 : Values are measured according to HIWIN measuring standard.

*3 : After error compensation.

*4 : The Force-Velocity Curve is the characteristic curve of the motor. The actual velocity will change with stroke, payload and acceleration. Please refer to the Velocity-Stroke Curve or Appendix A : Motor Sizing.

*5 : All specifications above are standard, contact HIWIN for special request.

Velocity-Stroke Curve

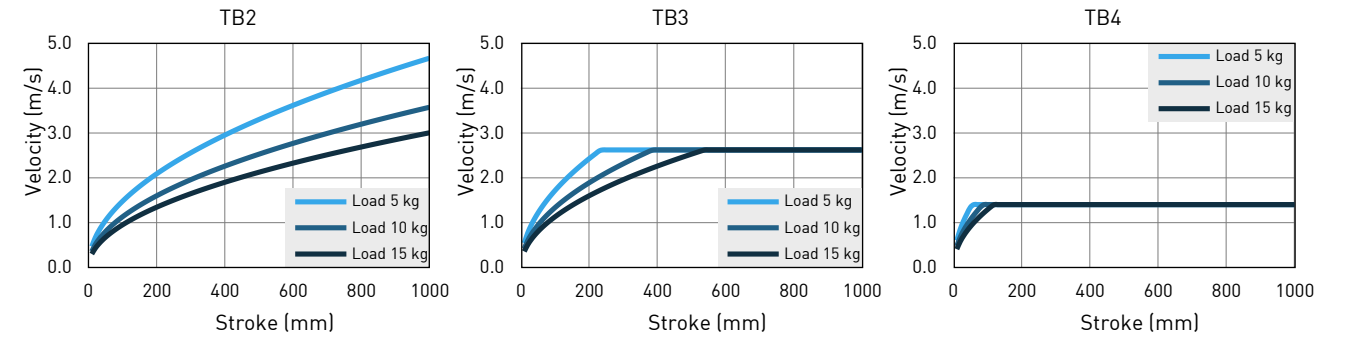

Cantilever Load Capability *2,3

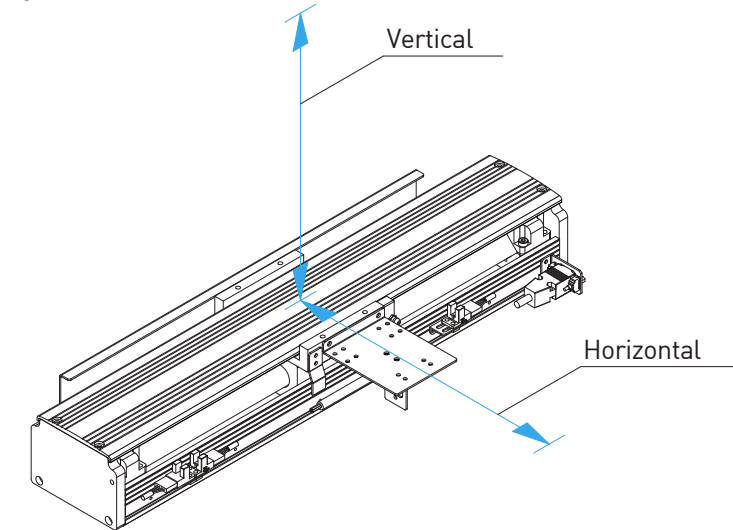

Vertical

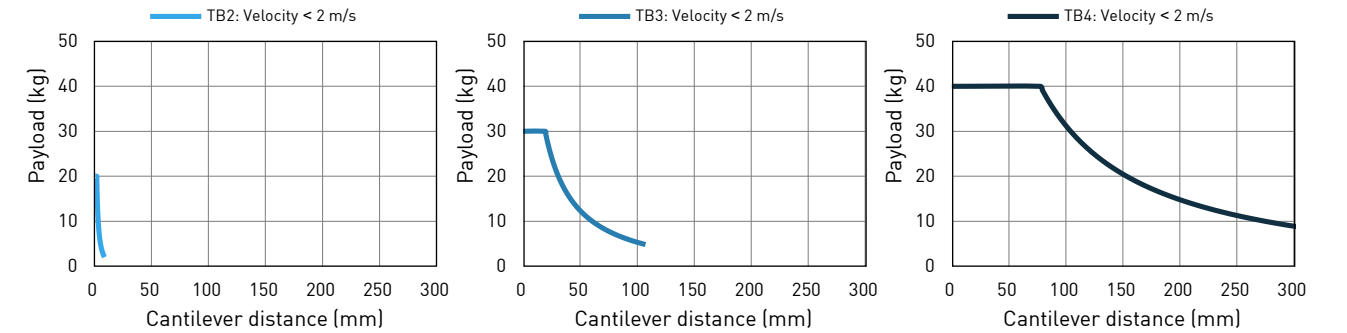

Horizontal

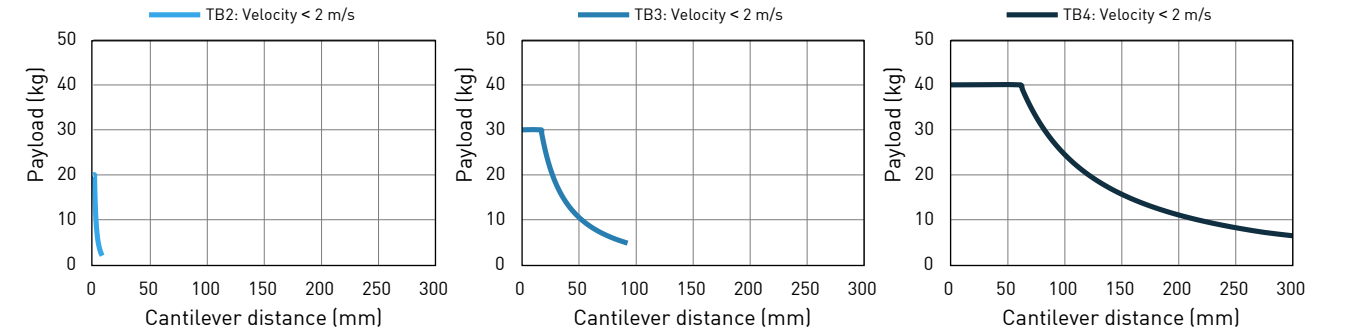

*1 : All values above are standard, contact HIWIN for special request.

*2 : Cantilever load capability due to different positioning stage, application rated life also vary.

*3 : The main reason for lifetime derives from linear guideway. For more details, please refer to HIWIN linear guideway catalog.

Table2-23 LMTB2 Shaft type linear motor stage specifications

Stroke (mm)	L (mm)	L1 (mm)	L2 (mm)	N	Mass (kg)
100	380	30	80	2	8.2
200	480	80	80	2	9.6
300	580	55	80	3	11.0
400	680	30	80	4	12.4
500	780	80	80	4	13.8
600	880	55	80	5	15.2
700	1020	50	100	6	17.1
800	1120	25	100	7	18.5
900	1220	75	100	7	19.8
1000	1320	50	100	8	21.2

* Absolute accuracy is after error mapping (with HIWIN drive).

Table2-24 LMTB3 Shaft type linear motor stage specifications

Stroke (mm)	L (mm)	L1 (mm)	L2 (mm)	N	Mass (kg)
100	425	52.5	80	2	9.5
200	525	27.5	80	3	10.9
300	625	77.5	80	3	12.3
400	725	52.5	80	4	13.6
500	825	27.5	80	5	15.0
600	925	77.5	80	5	16.4
700	1055	72.5	100	6	18.3
800	1165	47.5	100	7	19.7
900	1265	22.5	100	8	21.1
1000	1365	72.5	100	8	22.5

* Absolute accuracy is after error mapping (with HIWIN drive).

■ Dimension

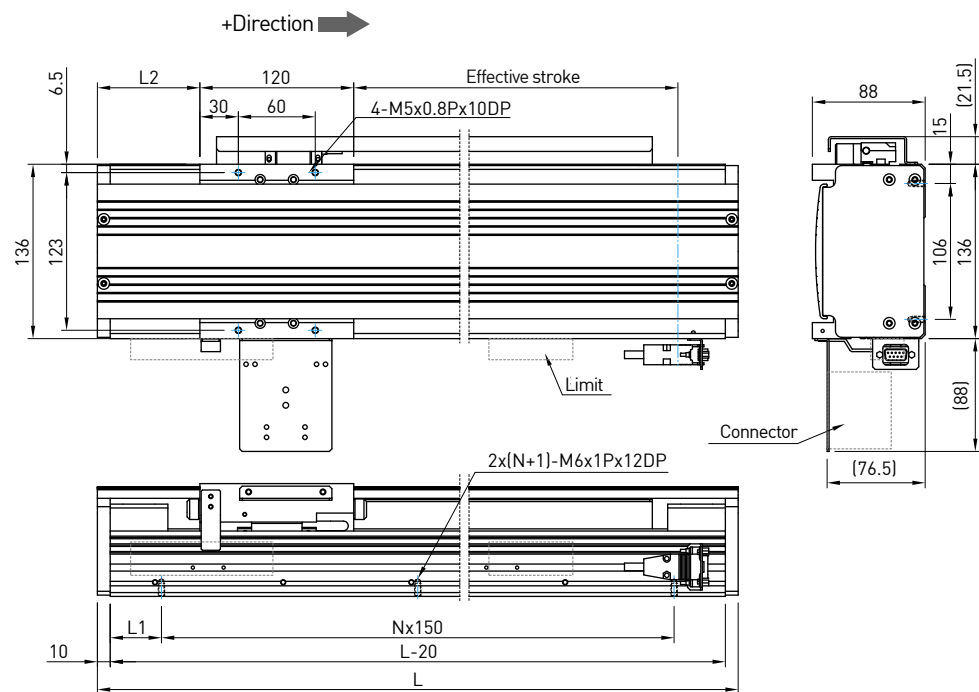

■ Dimension

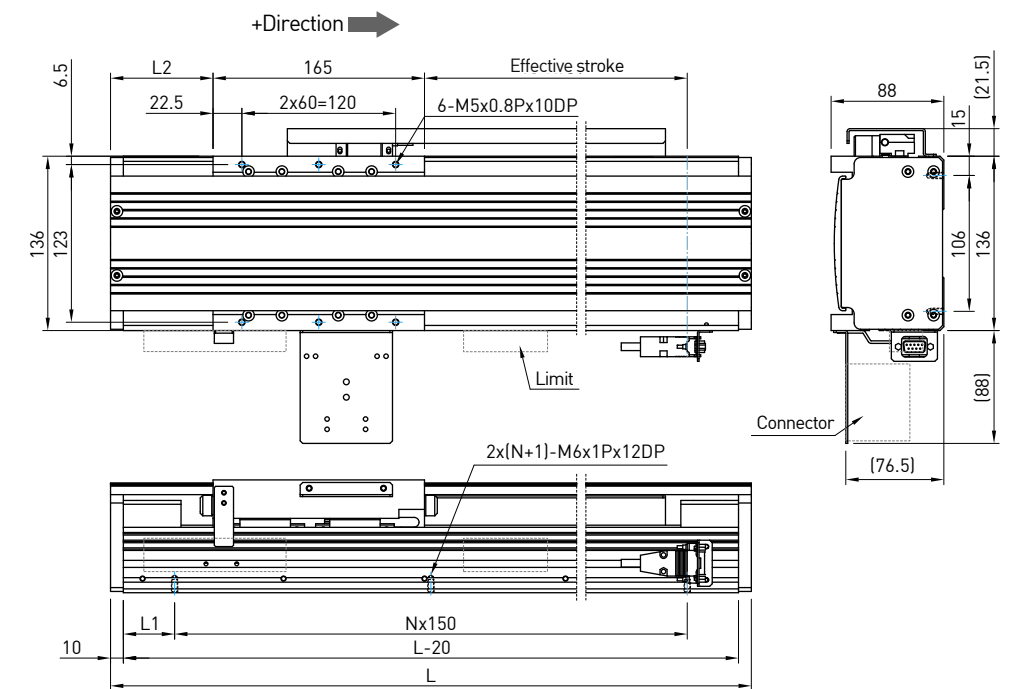
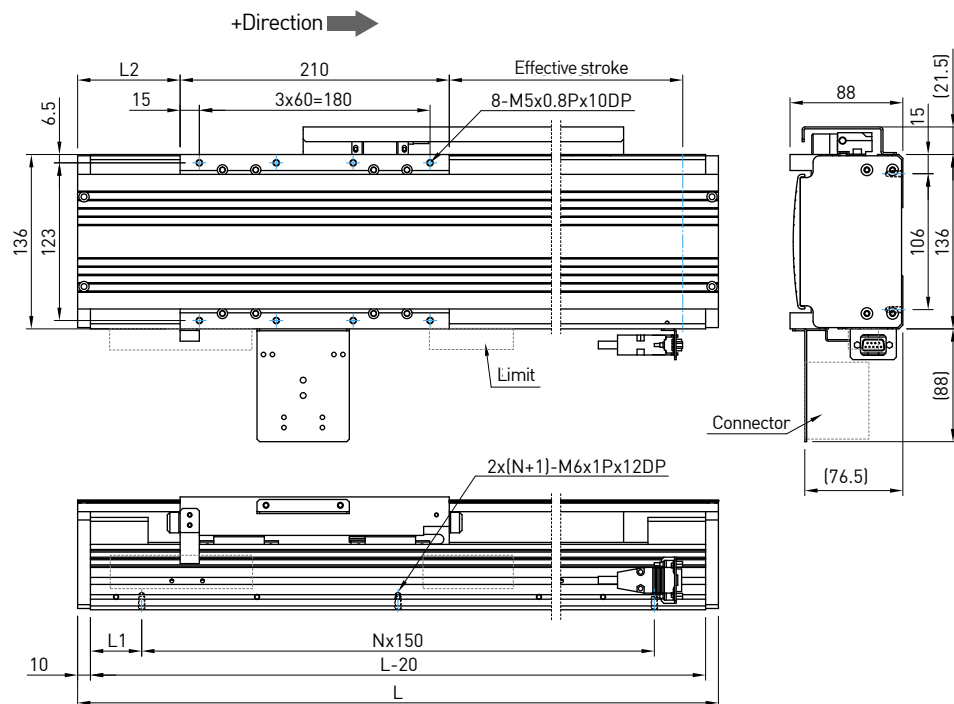

Table2-25 LMTB4 Shaft type linear motor stage specifications

Stroke (mm)	L (mm)	L1 (mm)	L2 (mm)	N	Mass (kg)
100	470	75	80	2	11
200	570	50	80	3	12.4
300	670	25	80	4	13.8
400	770	75	80	4	15.2
500	870	50	80	5	16.6
600	970	25	80	6	18
700	1110	20	100	7	19.9
800	1210	70	100	7	21.3
900	1310	45	100	8	22.7
1000	1410	20	100	9	24.1

* Absolute accuracy is after error mapping (with HIWIN drive).

Dimension



2.4.4 LMTC2 Shaft motor stage

Table2-26 LMTC2,3,4 stage specification

Specification	TC2	TC3	TC4
Continuous force, F_c (N)	92	138	184
Peak force, F_p (N)	368	552	736
Stroke (mm)	100-1000		
Resolution	1.0 μ m		
Repeatability (μ m) *2	± 1		
Accuracy (μ m) *2,3	± 3		
Horizontal straightness (μ m)	10 / 500 mm		
Vertical straightness (μ m)	20 / 500 mm		
Moving mass (kg)	4.0	5.7	6.9

Force-Velocity Curve (DC bus = 325V) *4

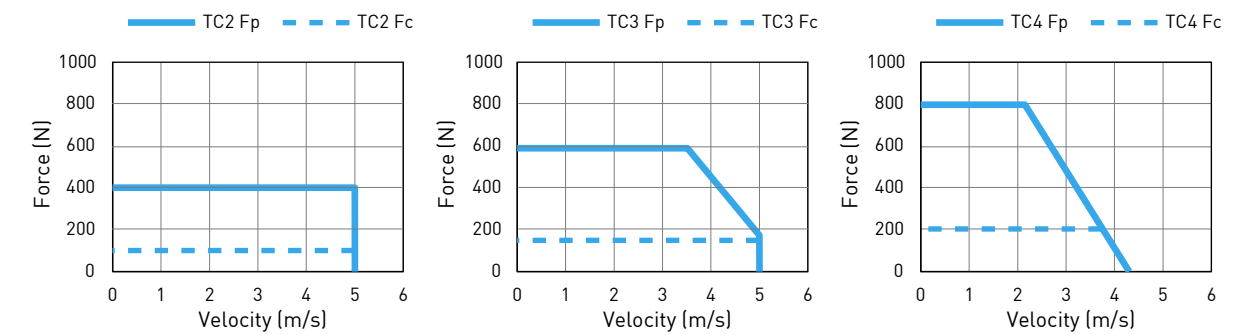

Acceleration-Payload Curve

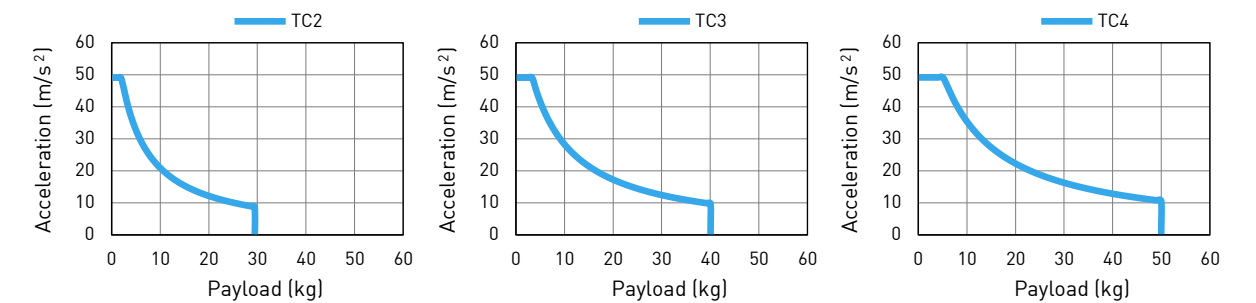

*1 : All values are measured on a granite table, all stage mounting holes are well fixed.
 *2 : Values are measured according to HIWIN measuring standard.
 *3 : After error compensation.
 *4 : The Force-Velocity Curve is the characteristic curve of the motor. The actual velocity will change with stroke, payload and acceleration. Please refer to the Velocity-Stroke Curve or Appendix A : Motor Sizing.
 *5 : All specifications above are standard, contact HIWIN for special request.

Velocity-Stroke Curve

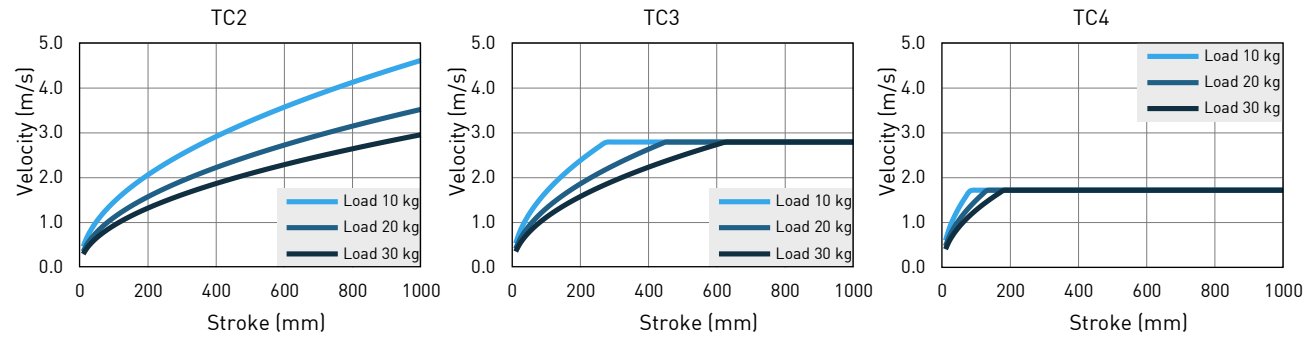

Cantilever Load Capability*2,3

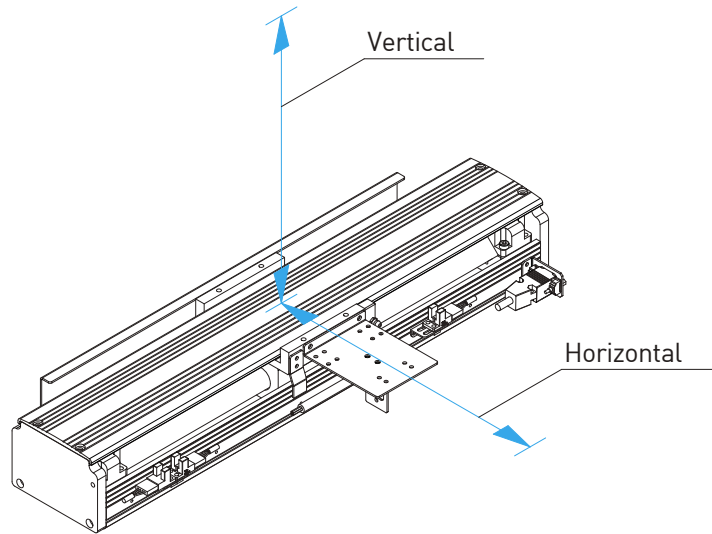

Vertical

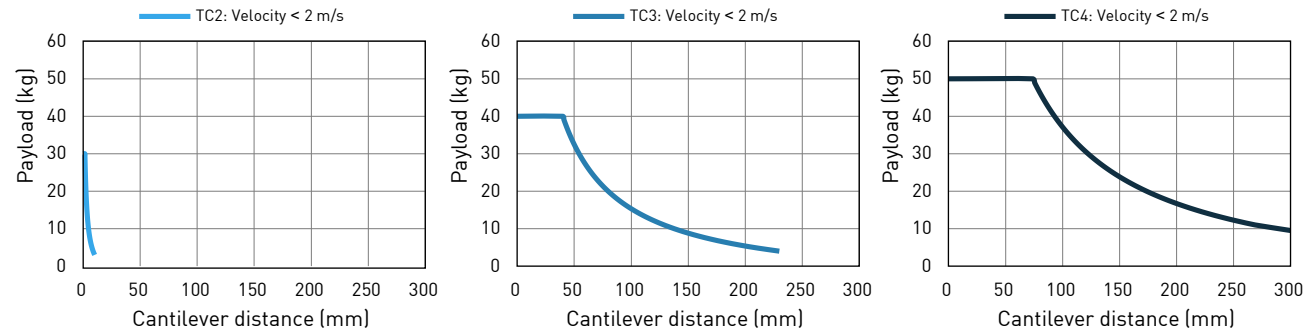

Horizontal

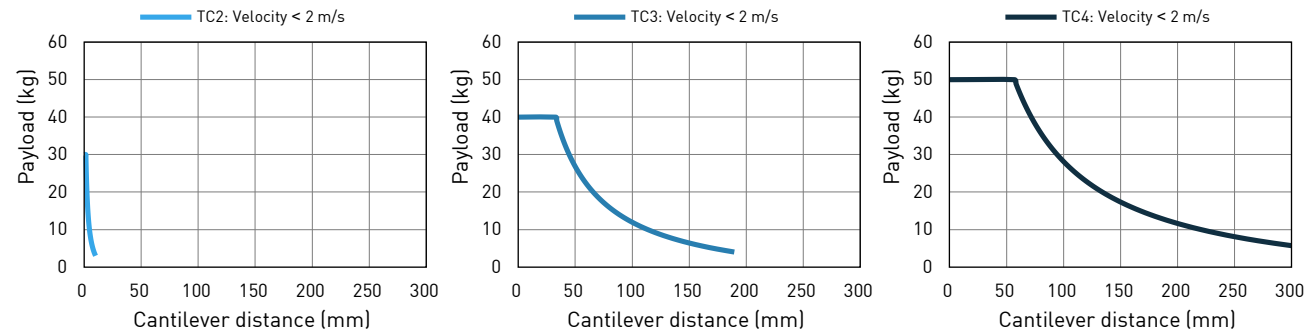
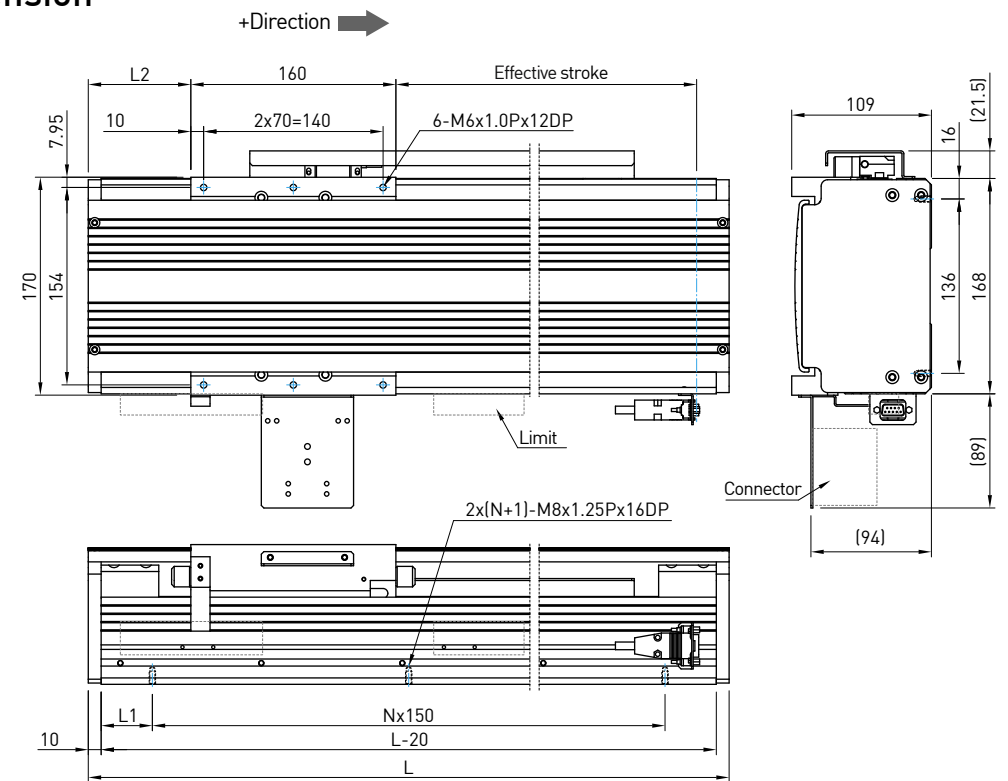

Table2-27 LMT2 Shaft type linear motor stage specifications

Stroke (mm)	L (mm)	L1 (mm)	L2 (mm)	N	Mass (kg)
100	420	50	80	2	14.1
200	520	25	80	3	16.2
300	620	75	80	3	18.3
400	720	50	80	4	20.4
500	820	25	80	5	22.5
600	920	75	80	5	24.6
700	1020	50	80	6	27.5
800	1160	45	100	7	29.5
900	1260	20	100	8	31.6
1000	1360	70	100	8	33.7

* Absolute accuracy is after error mapping (with HIWIN drive).

Dimension



*1 : All values above are standard, contact HIWIN for special request.

*2 : Cantilever load capability due to different positioning stage, application rated life also vary.

*3 : The main reason for lifetime derives from linear guideway. For more details, please refer to HIWIN linear guideway catalog.

Table2-28 LMTc3 Shaft type linear motor stage specifications

Stroke (mm)	L (mm)	L1 (mm)	L2 (mm)	N	Mass (kg)
100	480	80	80	2	17
200	580	55	80	3	19.1
300	680	30	80	4	21.2
400	780	80	80	4	23.3
500	880	55	80	5	25.4
600	980	30	80	6	27.5
700	1080	80	80	6	30.4
800	1220	75	100	7	32.4
900	1320	50	100	8	34.5
1000	1420	25	100	9	36.6

* Absolute accuracy is after error mapping (with HIWIN drive).

Table2-29 LMTc4 Shaft type linear motor stage specifications

Stroke (mm)	L (mm)	L1 (mm)	L2 (mm)	N	Mass (kg)
100	540	35	80	3	19.4
200	640	10	80	4	21.5
300	740	60	80	4	23.6
400	840	35	80	5	25.7
500	940	10	80	6	27.8
600	1040	60	80	6	29.9
700	1140	35	80	7	32.9
800	1280	30	100	8	34.9
900	1380	80	100	8	37
1000	1480	55	100	9	39.1

* Absolute accuracy is after error mapping (with HIWIN drive).

■ Dimension

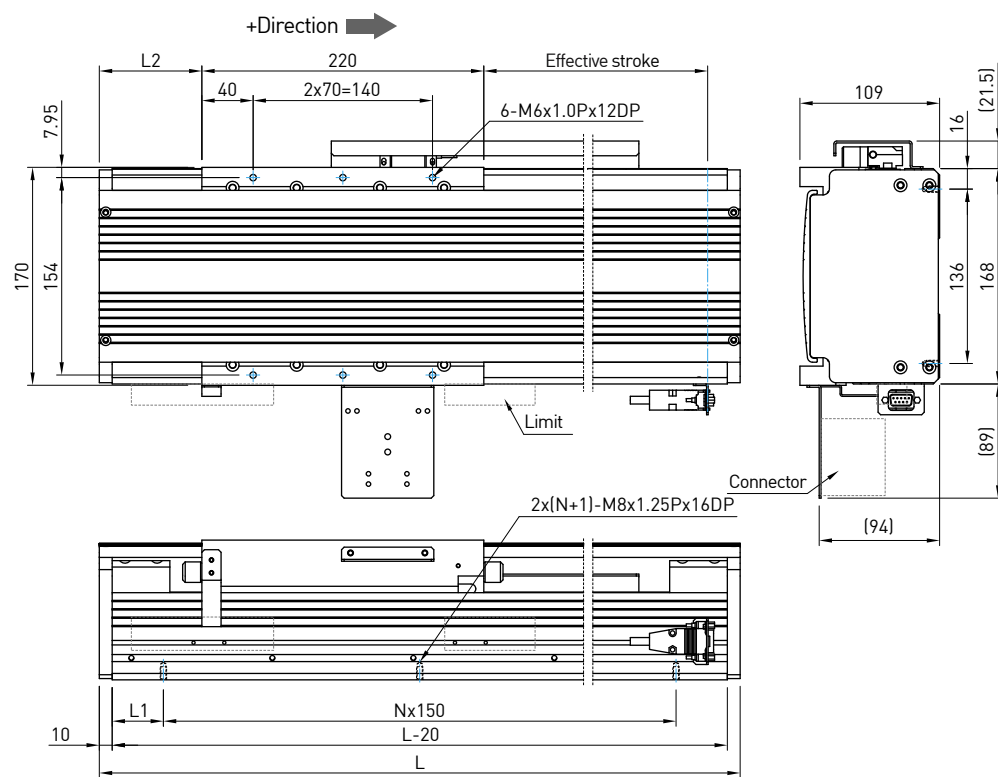

■ Dimension

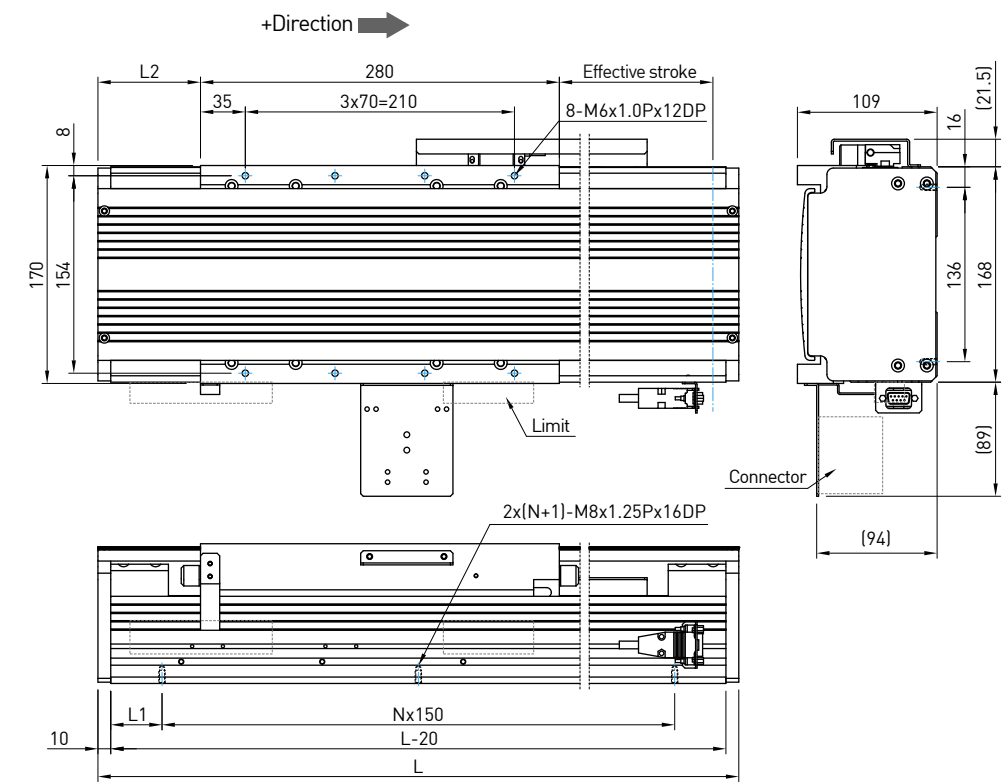

2.5 X-Y stage

LMX1 series linear motor stages can be assembled into an X-Y stage and configured for a variety of different X and Y strokes.

2.5.1 LMX2E-CB5-CB8 X-Y stage

- High speed
- No cogging
- High precision
- Easy to assemble
- High stiffness aluminum structure
- Ironless linear motor
- Optical inspection

Without cover

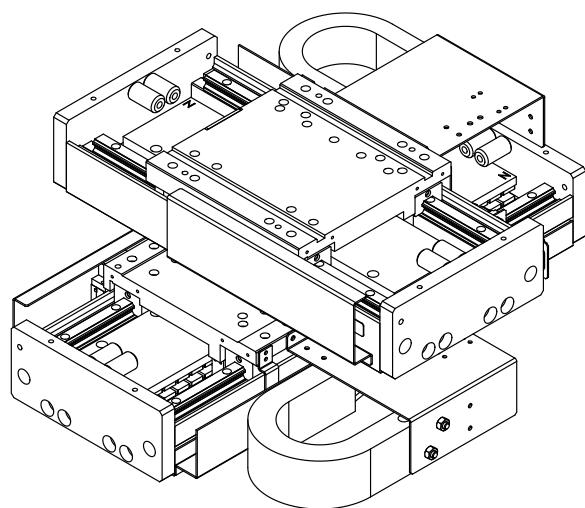

With cover

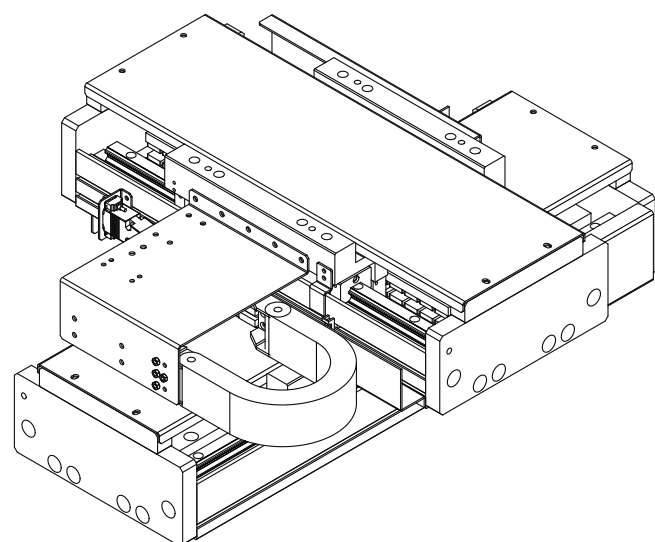

2.5.2 X-Y stage

LMX2E-CB5-CB8-200-300-G200

Stage type

LMX2E

Upper axis motor type

CB5

Lower axis motor model

CB8

Upper axis stroke

100:100mm
200:200mm
300:300mm

Lower axis stroke

100:100mm
200:200mm
300:300mm
400:400mm

Encoder type

0:none
A:40μm analog 1Vpp optical scale
B:20μm analog 1Vpp optical scale
D:1mm analog 1Vpp magnetic scale
E:TTL digital 1μm resolution magnetic scale
G:TTL digital 1μm resolution optical scale (standard)
H:TTL digital 0.5μm resolution optical scale
K:TTL digital 0.1μm resolution optical scale
M:TTL digital 20nm resolution optical scale
P:40μm glass optical analog scale
X:Other (please remark desired specifications or product model)

Limit switch

0:None
1:Metal cover
2:Optical switch, NPN (standard)
3:Optical switch, PNP
4:Inductive type, NPN
C:Customized

Cover

0:None (standard)
A:Metal cover
B:Bellows
B:Customized
D:Non-woven

Cable chain

0:None (standard)
1:Horizontal direction (chain internal space 15x30mm)
2:Vertical direction (chain internal space 15x30mm)
C:Customized

Note : Contact HIWIN for customized specification.

Without cover

Table2-30 Without cover X-Y stage product specifications

X-Stroke (mm)	Y-Stroke (mm)	LX (mm)	LY (mm)	L1 (mm)	L2 (mm)	N	Absolute accuracy (μm)	Resolution (μm)	Repeatability (μm)	Orthogonality (arc-sec)	X moving unit mass (Kg)	Y moving unit mass (Kg)	Mass (kg)
100	100	400	500	85	111	1 ¹	±3	1	±1	±5	2.5	20	44
100	200	400	600	60	111	3	±3		±1	±5	2.5	20	46
200	200	500	600	60	161	4	±3		±1	±5	2.5	22	48
100	300	400	700	35	111	5	±3		±1	±5	2.5	20	48
200	300	500	700	35	161	5	±3		±1	±5	2.5	22	50
300	300	600	700	35	211	6	±3		±1	±5	2.5	24	52
100	400	400	800	85	111	7	±3		±1	±5	2.5	20	50
200	400	500	800	85	161	7	±3		±1	±5	2.5	22	52
300	400	600	800	85	211	8	±3		±1	±5	2.5	24	54

* 1: When the stroke is 100mm, the mounting holes spacing is 300mm.
 * 2: Absolute accuracy is after error mapping (with HIWIN drive).
 * 3: Except resolution magnetic scale.
 * 4: For higher resolution, please contact HIWIN MIKROSYSTEM.

2.5.3 LMX2E-CB5CB8 X-Ystage-cover type

Different stroke and function of dual axes stages consist of various standard single axes. This will shorten the development and mass production lead time. It can be applied in machine tool and semiconductor industry.

- High speed
- No cogging
- High precision
- Easy to assemble
- Optical detection application
- High rigid aluminum structure
- Ironless linear motor

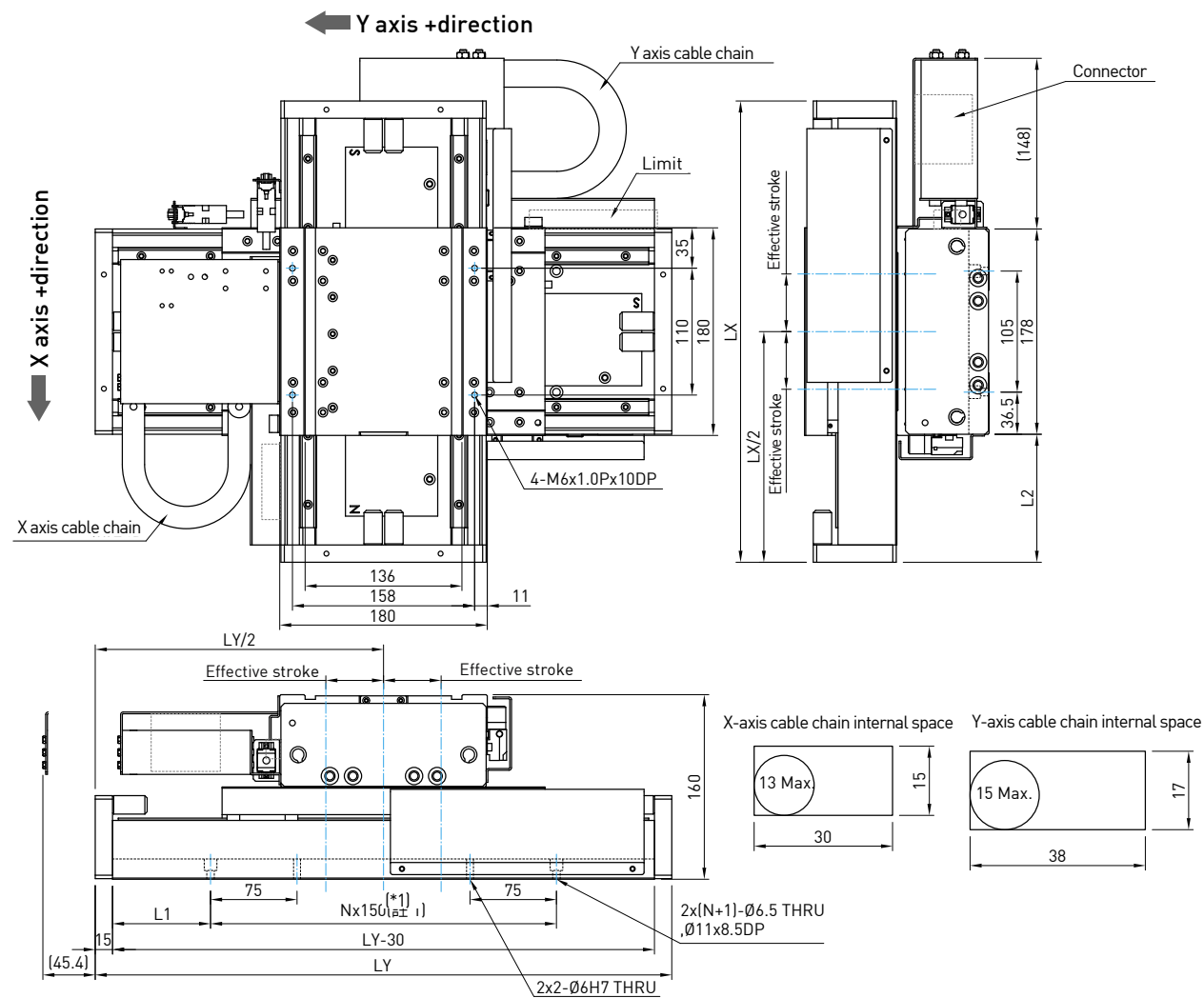
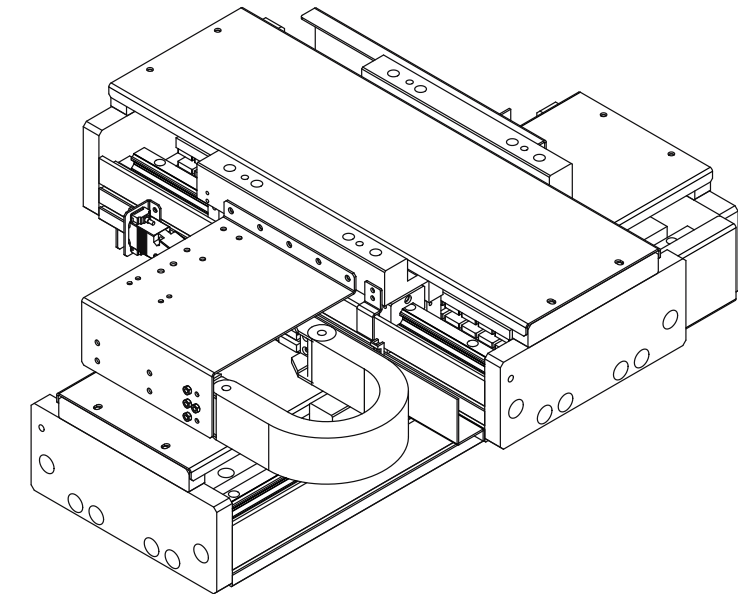

With cover type

Table2-31 With cover X-Y stage product specifications

X-Stroke (mm)	Y-Stroke (mm)	LX (mm)	LY (mm)	L1 (mm)	L2 (mm)	N	Absolute accuracy (μm)	Resolution (μm)	Repeatability (μm)	Orthogonality (arc-sec)	X moving unit mass (Kg)	Y moving unit mass (Kg)	Mass (kg)
100	100	400	500	85	111	1 ^{*1}	±3	1	±1	±5	3	21	46
100	200	400	600	60	111	3	±3		±1	±5	3	21	48
200	200	500	600	60	161	4	±3		±1	±5	3	23	50
100	300	400	700	35	111	5	±3		±1	±5	3	21	50
200	300	500	700	35	161	5	±3		±1	±5	3	23	52
300	300	600	700	35	211	6	±3		±1	±5	3	25	54
100	400	400	800	85	111	7	±3		±1	±5	3	21	52
200	400	500	800	85	161	7	±3		±1	±5	3	23	54
300	400	600	800	85	211	8	±3		±1	±5	3	25	56

* 1: When the stroke is 100mm, the mounting holes spacing is 300mm.
 * 2: Absolute accuracy is after error mapping (with HIWIN drive).
 * 3: Except resolution magnetic scale.
 * 4: For higher resolution, please contact HIWIN MIKROSYSTEM.

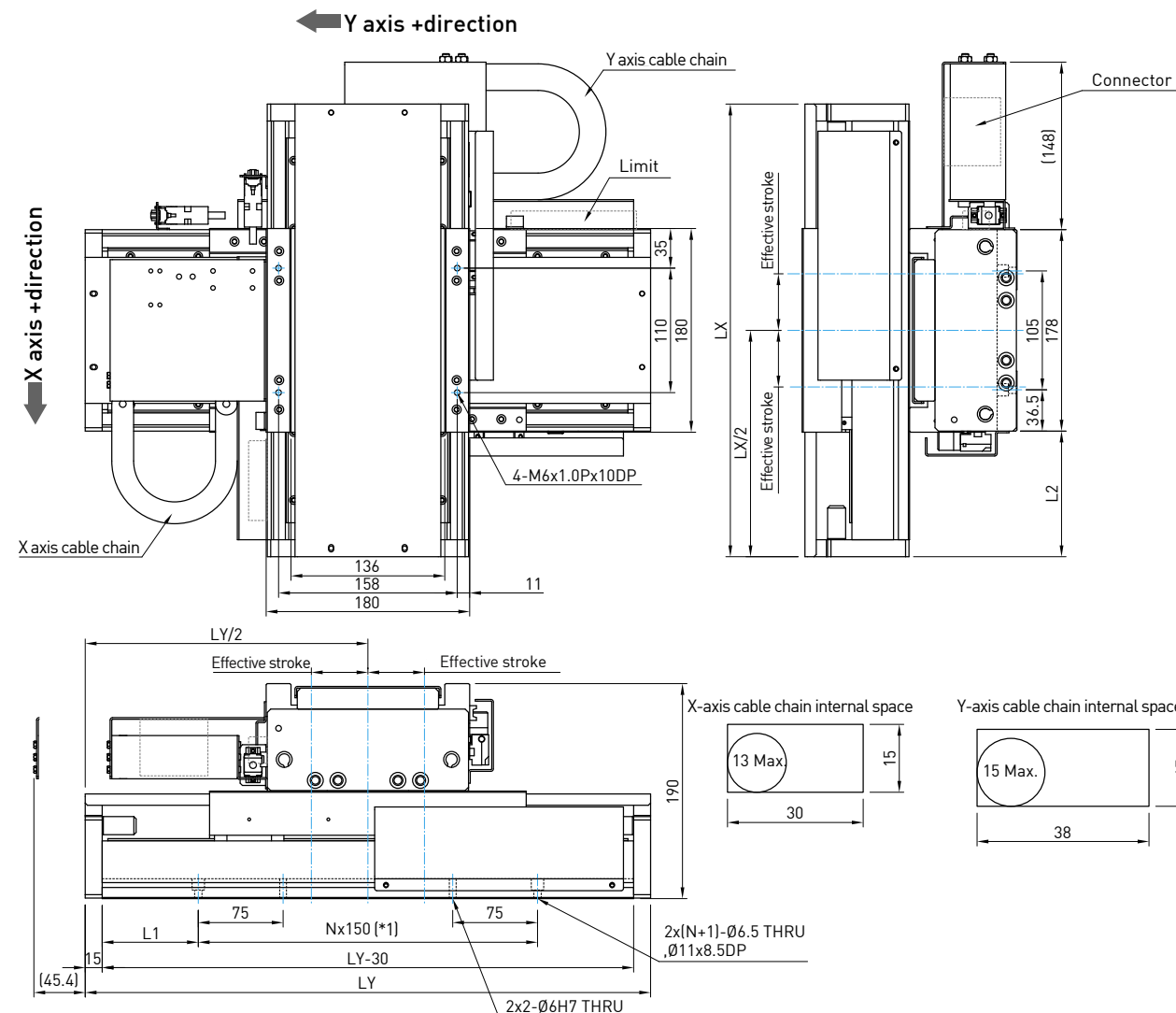

2.6 Gantry Stage

LMG2A series standardized gantry system is a unilateral drive system. LMG2A-C applies to ironless linear motor, and LMG2A-S applies to iron core linear motor.

2.6.1 Gantry stage LMG2A-CB6-CC8

- High acceleration
- No cogging
- Low inertia
- Easy to assemble
- High stiffness aluminum gantry structure
- Equipped with ironless linear motor
- Optical detection application

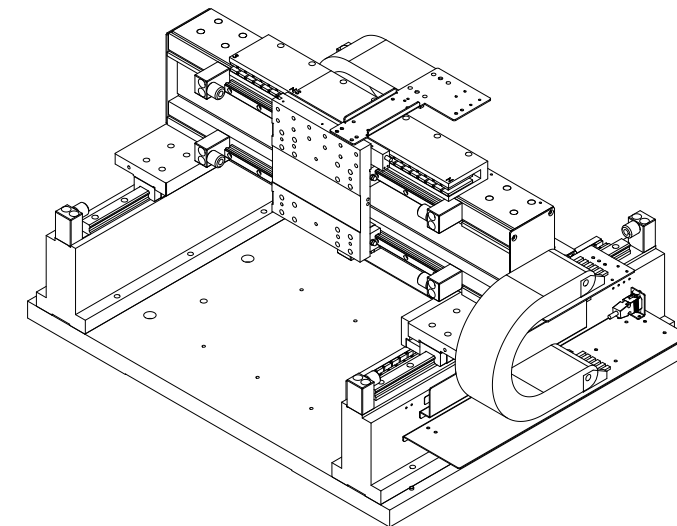

2.6.2 Gantry stage

LMG2A-CB6-CC8-300-400-G200

Stage type

LMG2A

Upper axis motor type

CB6

Lower axis motor model

CC8

Upper axis stroke

200:200mm 500:500mm
300:300mm 600:600mm
400:400mm

Lower axis stroke

100:100mm 500:500mm
200:200mm 600:600mm
300:300mm
400:400mm

Encoder type

0:none
A:40μm analog 1Vpp optical scale
B:20μm analog 1Vpp optical scale
D:1mm analog 1Vpp magnetic scale
E:TTL digital 1μm resolution magnetic scale
G:TTL digital 1μm resolution optical scale (standard)
H:TTL digital 0.5μm resolution optical scale
K:TTL digital 0.1μm resolution optical scale
M:TTL digital 20nm resolution optical scale
P:40μm glass optical analog scale
X:Other (please remark desired specifications or product model)

Limit switch

0:None
1:Metal cover
2:Optical switch, NPN (standard)
3:Optical switch, PNP
4:Inductive type, NPN
C:Customized

Cover

0:None (standard)
A:Metal cover
B:Bellows
B:Customized
D:Non-woven

Cable chain

0:None (standard)
1:Horizontal direction (chain internal space 15x30mm)
2:Vertical direction (chain internal space 15x30mm)
C:Customized

Note : Contact HIWIN for customized specification.

Table2-31 Gantry stage LMG2A product specifications

X-Stroke (mm)	Y-Stroke (mm)	W (mm)	W1 (mm)	W2 (mm)	W3 (mm)	N	L (mm)	L1 (mm)	Absolute accuracy (μm)	Resolution (μm)	Repeatability (μm)	Orthogonality (arc-sec)	X moving unit mass (Kg)	Y moving unit mass (Kg)	Mass (kg)
200	200	740	440	817	110	2	600	100	±9	1μm	±3	±5	5	31	50
300	300	840	540	917	135	3	700	50	±9		±3	±5	5	35	52
400	400	940	640	1017	160	3	800	100	±12		±4	±5	5	39	54
500	500	1040	740	1117	185	4	900	50	±12		±4	±5	5	43	54
600	600	1140	840	1217	210	4	1000	100	±12		±4	±5	5	47	56

* 1: Absolute accuracy is after error mapping (with HIWIN drive).

* 2: Except resolution magnetic scale.

* 3: For higher resolution, please contact HIWIN MIKROSYSTEM.

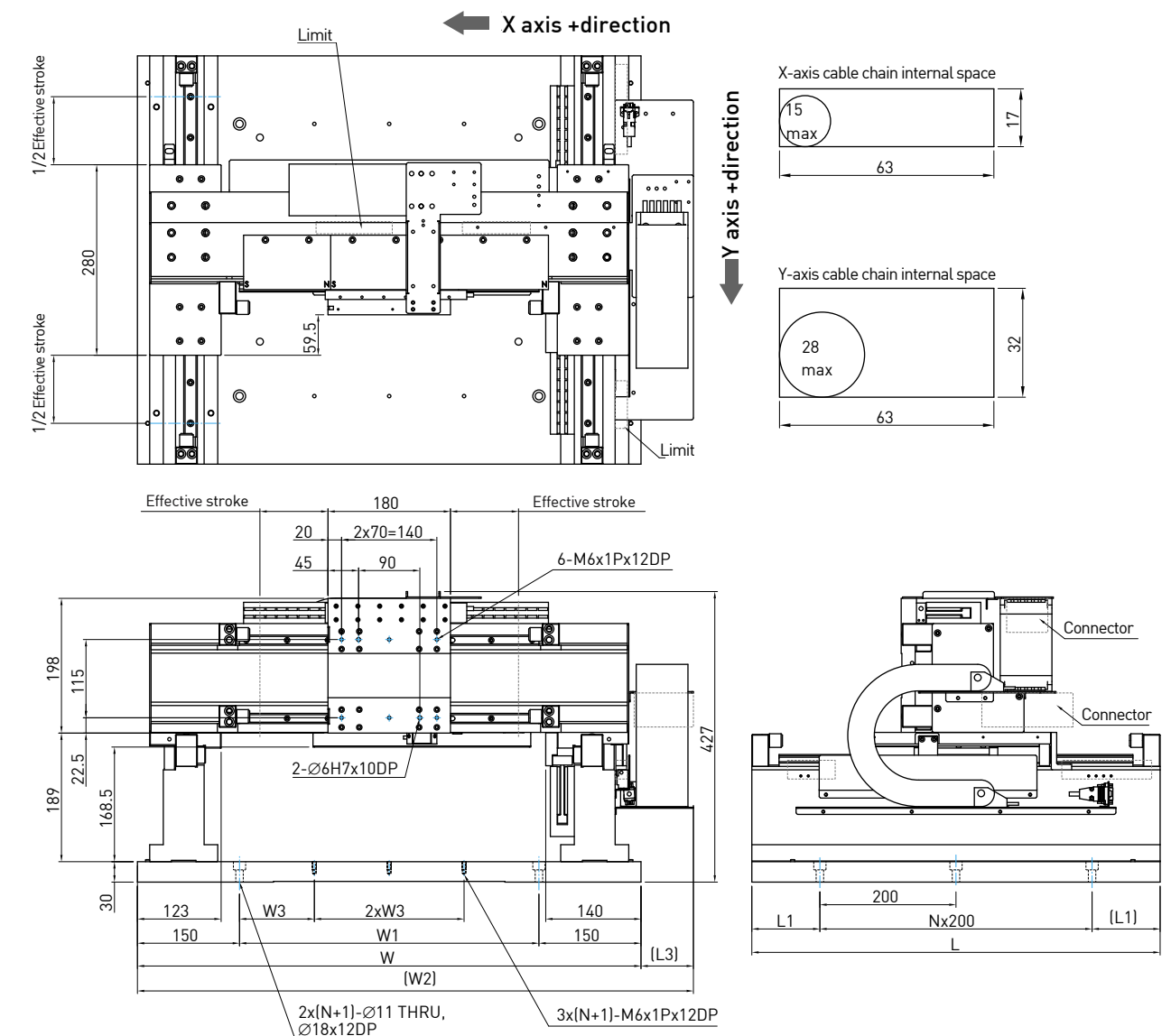

2.7 Air bearing stage

2.7.1 Non-contact air bearing stage LMAS

- Non-contact air bearing provides better positioning accuracy
- Embedded magnetic preloading design, enhance stability
- Provide extremely smooth motion and rapid settling time
- Equipped with ironless linear motor, no cogging
- High resolution feedback with linear optical encoder
- Equipped with high flexible cable
- For clean room, no need to lubricate and easy to maintain
- Low velocity ripple
- Available for precision positioning, calibration systems, scanning applications, wafer inspection

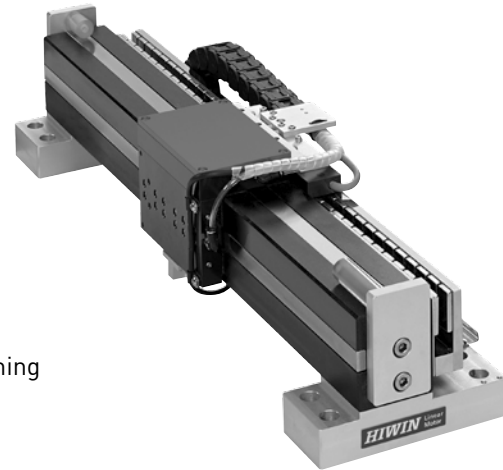

Specifications	Unit	AS200	AS400	AS600	AS800	AS1000
Stroke	mm	200	400	600	800	1000
Motor type	-	LMCB8				
Bus voltage	V	Up to 325 VDC				
Instant current	A(pk)	6				
Continuous current	A(rms)	2.0				
Feedback system	-	Optical Linear Encoder: Analog period 20μm				
Resolution*1	μm	4				
Repeatability	μm	±0.3	±0.4	±0.4	±0.5	±0.5
Positioning accuracy*2	μm	±3.0	±4.0	±4.0	±5.0	±5.0
Horizontal straightness*3	μm	±1.0	±1.0	±1.5	±2.0	±2.5
Vertical straightness*3	μm	±1.0	±1.0	±1.5	±2.0	±2.5
Pitch*3	arc-sec	±2.0	±2.5	±3	±3.5	±4
Yaw*3	arc-sec	±2.0	±2.5	±3	±3.5	±4
Roll*3	arc-sec	TBD				
Allowable payload	kg	10				
Max. speed*4*5	m/s	1	1.2	1.4	1.6	2
Max. acceleration*5	m/s ²	10	11	12	13	14
Working pressure*6	N/m ²	4x10 ⁵ N/m ² ± 2x10 ⁴ N/m ²				
Moving unit mass*7	kg	8				
Moving unit material	-	Aluminum (hardened anodized)				
Base	-	Granite				

*1: The maximum resolution is up to 4096 times, resolution accuracy is about 4 nm
 *2: Absolute accuracy is after error mapping.
 *3: Required specification is restricted by load, this specification is based on empty load
 *4: Must comply with the resolution of encoder and the number of mass transfer rate
 *5: Based on the limitations of motor instantly force, only allow moving unit mass about 8Kg (center load)
 *6: It is recommended to link pressure switch on the emergency stop devices to protect air bearing from overloading
 *7: Free of load

■ Dimensions

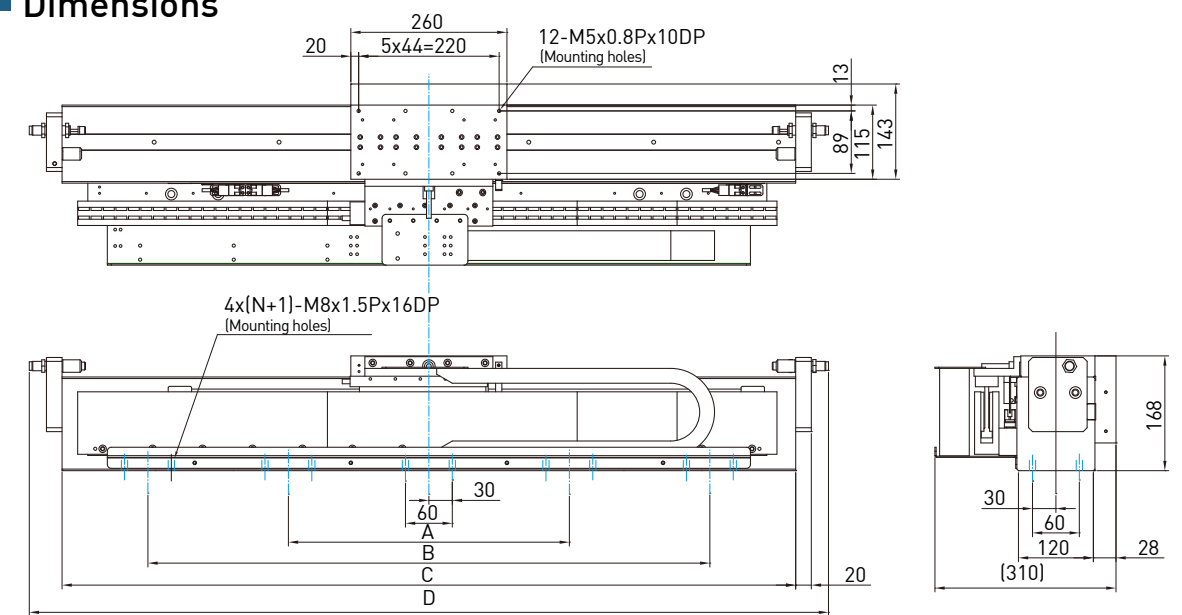

Type	Stroke	Dimensions				
		A	B	C	D	N
AS200	200	280	-	526	619	2
AS400	400	480	-	726	819	2
AS600	600	580	-	926	1019	2
AS800	800	440	880	1126	1219	4
AS1000	1000	540	1080	1326	1419	4

2.7.2 Air bearing stage LMAP series

Low profile, XY symmetric structure design, with high stiffness granite base magnetic preload designed to enhance stability, with excellent geometrical property; applies ironless linear motor, no cogging to parid setting time, that provides excellent smooth motion and positioning accuracy; strong beam design uses high stiffness lightweight aluminum, reduces weight of moving unit; gantry dual-drive structure and use of two sets of optical linear encoder for feedback compensation, offers dynamic control and error mapping; for clean room, no lubrication for easy maintenance and provides high flexible cable management.

Applications

- Wafer inspection system
- Micromachining system
- Laser lithography
- Semiconductor inspection system
- Exposure system

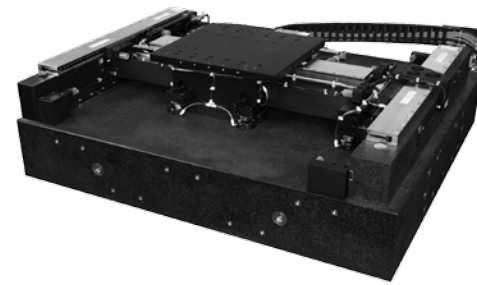
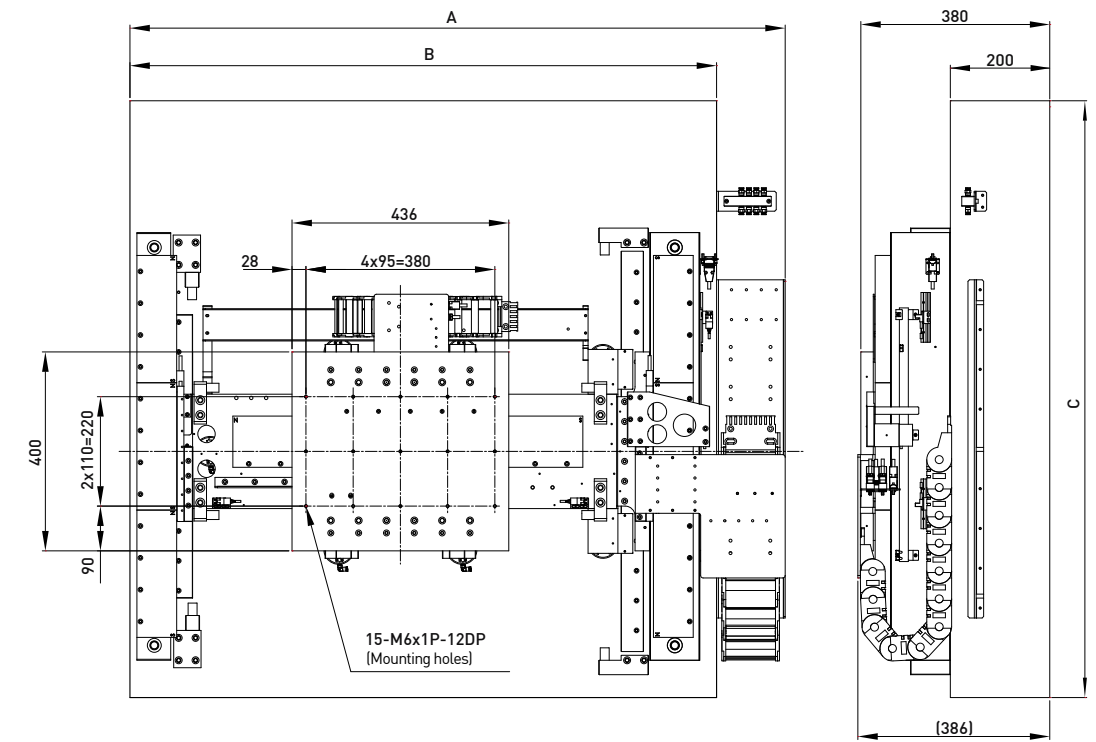

Table 2-34 LMAP series product specification

Basic model	Unit	AP250	AP450	AP650
Stroke	mm	250x250	450x450	650x650
Motor specification	-	Beam axis: LMCC8 Gantry axes: LMCCB x 2		
Bus Voltage	V	Up to 325 VDC		
Instant current	A(pk)	6.0		
Continuous current	A(rms)	2.0		
Feedback system	-	Optical Linear Encoder: Analog period 40µm glass scale		
Resolution*1	µm	10		
Repeatability	µm	±0.5	±0.5	±0.5
Positioning accuracy*2	µm	±1.5	±1.5	±1.5
Horizontal straightness*3	µm	±1.5	±2	±2.5
Vertical straightness*3	µm	±1.5	±2	±2.5
Orthogonality	arc-sec	±2.5	±2.5	±3.5
Pitch*3	arc-sec	±6	±8	±12
Yaw*3	arc-sec	±1.5	±2	±2.5
Roll*3	arc-sec	TBD		
Allowable load	kg	30		
Max. speed*4*5	m/s	0.6	0.8	1
Max. acceleration*5	m/s ²	4	4.5	5
Working pressure*6	N/m ²	4x10 ⁵ N/m ² ± 2x10 ⁴ N/m ²		
Moving unit mass*7	kg	Bridge	30	
	kg	Gantry	75	85
Moving unit material	-	Aluminum (hardened anodized)		
Base	-	Granite		

*1: The maximum resolution is up to 4096 times, resolution accuracy is about 4 nm
 *2: Error after compensation
 *3: Required specification is restricted by load, this specification is based on empty load
 *4: Must comply with the resolution of encoder and the number of mass transfer rate
 *5: Based on the limitations of motor instantly force, only allow moving unit mass about 8Kg (center load)
 *6: It is recommended to link pressure switch on the emergency stop devices to protect air bearing from overloading
 *7: Free of load

Dimensions



Type	Stroke	Dimensions		
		A	B	C
AP250	250x250	1168	1030	1100
AP450	450x450	1368	1230	1300
AP650	650x650	1568	1430	1500

3 Customized Positioning Systems

The standardized positioning axes presented in this catalogue make it possible to handle many kinds of positioning tasks. For positioning tasks, that cannot be solved using standard axes, HIWIN engineers are able to work out an optimized solution for customers. The inquiry form at the end of this catalogue serves to help our application engineers make a preliminary design.

A sampling of customized solutions is shown here. In several examples, mechanics are not the only parts customized. For instance, with the planar motors, special software is developed in order to obtain optimal integration of the positioning system to the production process.

3.1 Examples

Economical Pick & Place and Inspection

XY gantry systems are economical for many applications. Gantry axes are assembled from standard components.

- Standard axes of the LMX1L series
- Repeatability $\pm 2 \mu\text{m}$
- Delivery with base frame



Microshapes and Macroshapes

Milling of microstructures with cutting tools and lasers are application areas in which gantry systems excel. They are also very economical to implement.

- Ironless motors LMC
- Repeatability $\pm 2 \mu\text{m}$
- Technology proven through countless worldwide installations

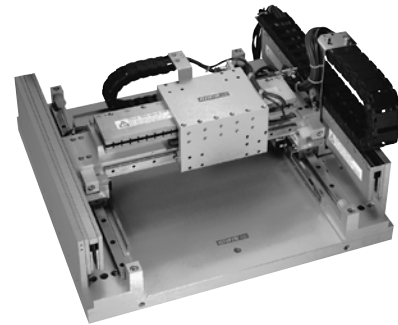

Planar Motors

Servo-planar motors provide an excellent technological stage for inspection tasks. During inspection of circuit boards, optical sensors are integrated to completely monitor the printed conductive tracks and SMD components.

- Virtually no wear due to an air bearing
- Guaranteed levelness for the complete stroke path (up to 1000 mm x 1000 mm)
- Repeatability $\pm 3 \mu\text{m}$

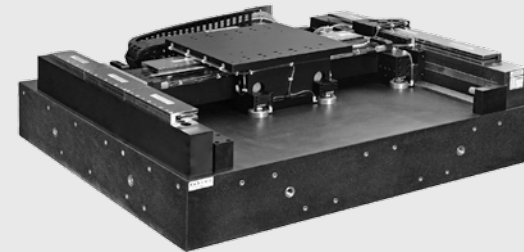

Semiconductor inspection and exposure

High precision cross stages with air-bearings are the prerequisites for surface monitoring and mask production, to find even the smallest errors, to produce precision masks, in wafer production for the electronics, chip and flat panel industries.

- Stroke 500 mm x 500 mm
- Vertical straightness
- Repeatability $\pm 0.5 \mu\text{m}$
- Accuracy $\pm 1.5 \mu\text{m}$

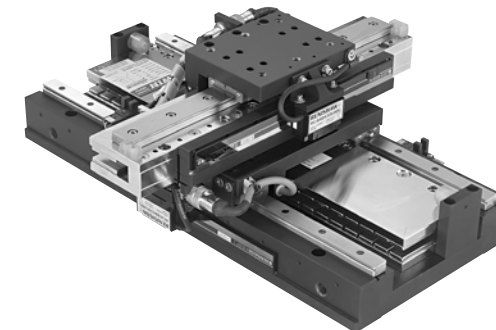

Microsystem Technology and Wafer Processing

Absolute precision and suitability for clean room conditions are the prerequisites for every drive in microsystem technology and wafer processing. Linear motor cross stages meet these requirements.

- Stroke 200 mm x 200 mm, optional 300 mm x 300 mm
- Levelness $\pm 4 \mu\text{m}$ across the complete stroke
- Repeatability $\pm 1 \mu\text{m}$ across both axes
- Accuracy $\pm 4 \mu\text{m}$ across both axes
- Clean room suitability class 100; optional class 10



Laser Scanners

Extremely smooth motion and long operating life are a must for optical inspection systems such as laser scanners. Linear motor stages with air bearings fulfill these requirements.

- Air bearing system without friction
- Ironless linear motors are not effected by cogging.
- Stroke up to 1,500 mm



Horizontal High-Speed Hot Weld Machine for Welding Synthetic Materials

Linear motor stages of the LMX1L series with absolute position measurement offer:

- Rapid initialization phase
- material when removed from the heated plate
- Welding is controlled by time, force and path
- Rapid load/unload system

Water Jet Application

LMSA multi-forcer linear stage provides 2.5m stroke and carries two HIWIN KK stages on the Z-axis. The lower 2 axes are also equipped with LMS high force liner motors and run under synchronization.

- No commutation required at power up
- Long stroke
- Delivered with base frame, cover and precision motion controller

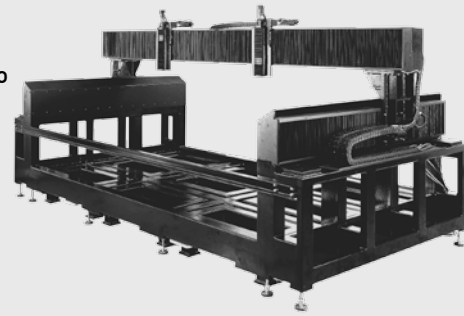

Total Solution for AOI Industry

LMC linear stage provides smooth motion for the special requirement in AOI applications. With the LMS linear stage mounted to the upper axis, the ballscrew driven Z-axis integrated with a CCD camera can attain high speeds.

- Repeatability ±1 μm
- Velocity ripple below 1.5 %
- Delivery with base frame and cover



Customized for Glass Working

The linear motor stage is designed to carry a working head to move above the flat table. The customer's laser head is for cutting double layer glasses.

- Gantry structure linear motor positioning stage for Gen. 5 glass
- 1300 mm x 1450 mm stroke
- Smooth motion
- Sinusoidal commutation and no cogging
- LMC series motors
- Repeatability ±2 μm
- Rigid base structure



Provide motion plan for customer

This is another AOI application, where customer needed high cost-performance ratio.

- Stroke 534mm x 534mm
- LMSA type gantry
- Special synchronous control for gantry
- Steel base frame
- Integrating PCB conveyor, PLC, IPC for customers
- Sub-micron repeatability
- Promising move and settle time 40mm within 200ms to ±1.5 μm

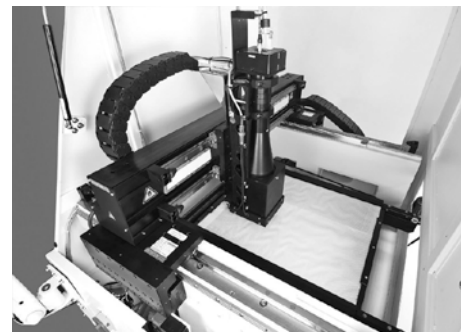

3.2 General type positioning stage

HIWIN offers a variety of customized positioning stages to satisfy customer requirements in a variety of technical fields, such as optical inspection, laser processing, plastic material coating, metal processing and other automated production equipment. Application industries include semiconductor industry, Optical elements, panel displays, medical equipment, machine tools, electronic components, MEMS and so on. Specifications diversification and the ability for rapid customization are combined to fully meet customer needs for mass production, a shorted product development process and strict environmental requirements.

■ Model code description

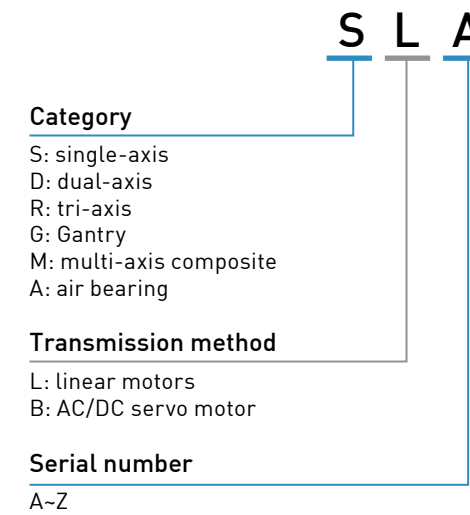

Note1 : Contact HIWIN for customized specification.

Note2: Starting from April 2016, users of LMS series linear motor positioning stage products, will be fully converted to LMSA series motors.

3.2 SLA series

- Max. velocity 5 m/s (no load).
- Max. stroke up to 6,000 mm or more.
- High stiffness structure.
- Suitable for point-to-point motion.
- Can be equipped with ironcore motor.
- With a special chain design, it can be installed upside down.

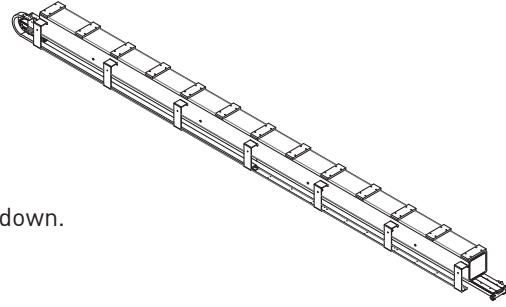

3.2.1 Industry applications

Automation equipment, glass substrate moving equipment

3.2.2 Performance specifications

Table3-1 LMX1L-S27-6200-X202 product specification

Stage type	LMX1L-S27-6200-X202
Motor specifications	Ironcore motor (can select ironless motor)
Stroke (mm)	6200
Max. force (N)/Continuous force(N)	1017/382
Repeatability (μm)	± 15 (apply HIWIN measurements)
Max. acceleration (m/s ²)	10 (with Payload)
Max. speed (m/s)	2 (with Payload)
Payload (kg)	5
Stage orientation	Upside down

Note : All specifications can be designed according to customer demand.

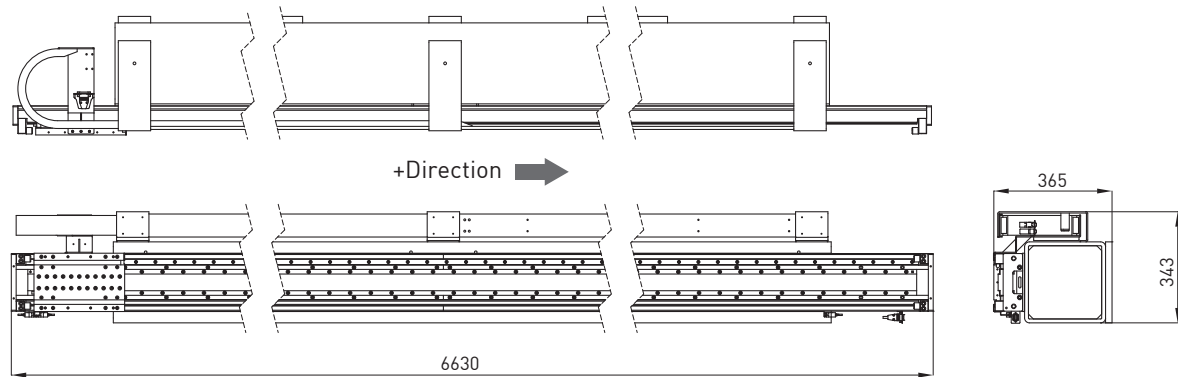

3.3 SLB series

- High stiffness design of base.
- Multi-forcer design.

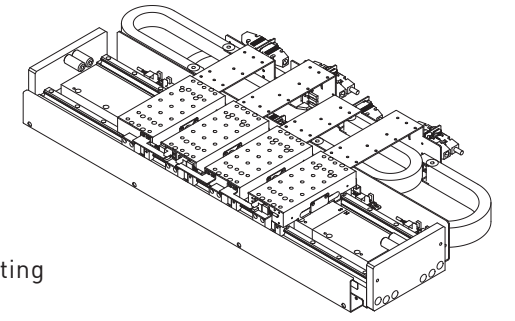

3.3.1 Industry applications

Large-scale inkjet printer, glass substrate/PCB board testing equipment, glass substrate exposure equipment

3.3.2 Performance specifications

Table3-2 LMX1C-CB2-4-290 product specification

Stage type	LMX1C-CB2-4-290
Motor Type	Ironless(/Ironcore) motor
Stroke(mm)	290
Peak Force(N)/Continuous Force(N)	144/36
Repeatability(μm)	± 1(with HIWIN solution)
Accuracy(μm)	± 3(after error mapping)
Max. Acceleration(m/s ²)	0.05(with payload)
Max. Velocity(m/s)	0.05(with payload)
Payload(kg)	25
Stage orientation	Side-Mount

Note : All specifications can be designed according to customer demand.

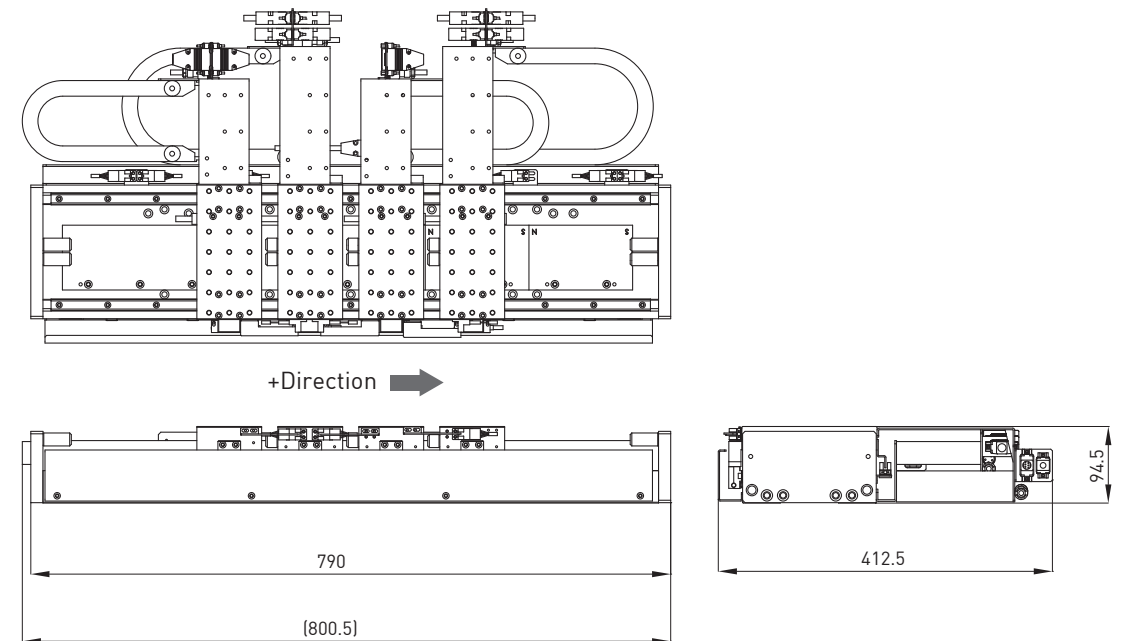

3.4 SLC series

- Uses dust-proof design.
- Uses granite base, high stiffness.
- Not easily influenced by environmental temperature.
- Can be equipped with ironless or ironcore motor.
- Horizontal straightness and vertical straightness up to $\pm 3 \mu\text{m}/\text{m}$.
- Design with hidden cable chain.

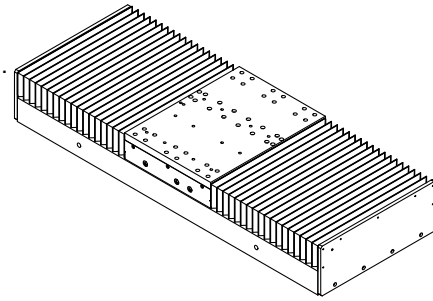

3.4.1 Industry applications

Automation equipment, laser cutting applications

3.4.2 Performance specifications

Table3-3 LMX1C-S27-1-460 product specification

Stage type	LMX1C-S27-1-460
Motor Type	Ironcore(/Ironless) motor
Stroke(mm)	460
Peak Force(N)/Continuous Force(N)	1017/382
Repeatability(μm)	± 1 (with HIWIN solution)
Accuracy(μm)	± 3 (after error mapping)
Max. Acceleration(m/s^2)	5(with payload)
Max. Velocity(m/s)	1(with payload)
Horizontal Straightness(μm)	± 3
Vertical Straightness(μm)	± 3
Payload(kg)	30
Stage orientation	Horizontal

Note : All specifications can be designed according to customer demand.

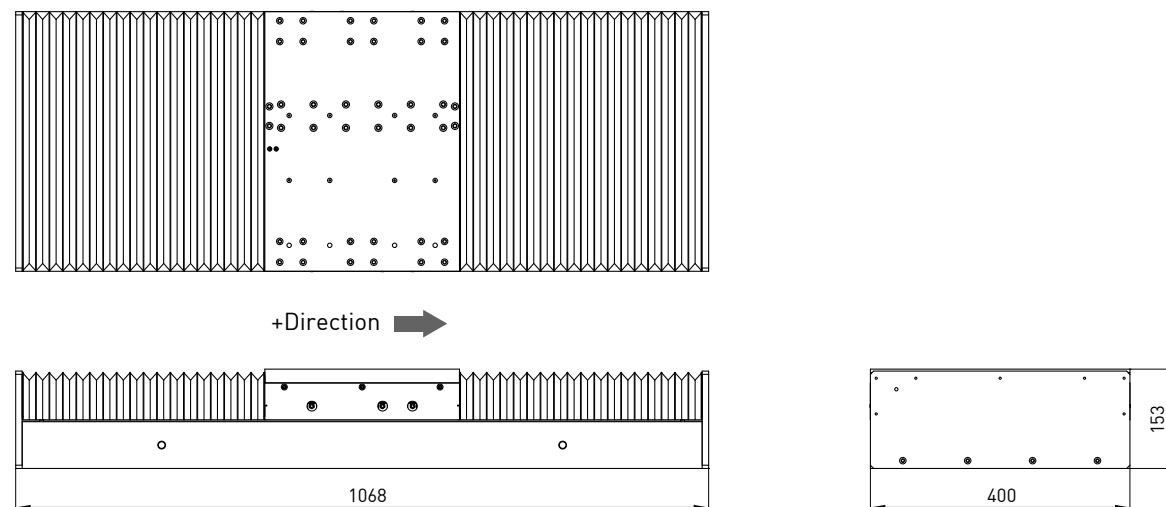

3.5 SLD series

- Vertical Applications.
- Integrate adjustable pneumatic counterweight module.
- Equipped with ironless motor.
- In line with the smaller space requirements.
- High-speed, lightweight design.

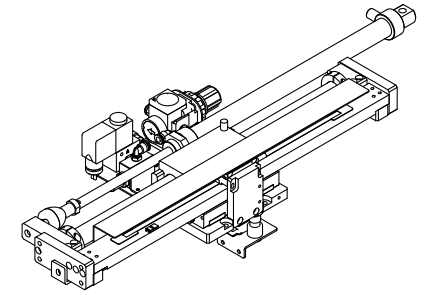

3.5.1 Industry applications

Automation equipment, high-speed pick and place feeding equipment, electronic component assembly equipment

3.5.2 Performance specifications

Table3-4 LMX1C-TA2-1-260 product specification

Stage type	LMX1C-TA2-1-260
Motor Type	Ironless motor
Stroke(mm)	260
Peak Force(N)/Continuous Force(N)	108/27
Repeatability(μm)	± 2 (with HIWIN solution)
Accuracy(μm)	± 6 (after error mapping)
Max. Acceleration(m/s^2)	10(with payload)
Max. Velocity(m/s)	1(with payload)
Payload(kg)	0.5
Stage orientation	Vertical

Note : All specifications can be designed according to customer demand.

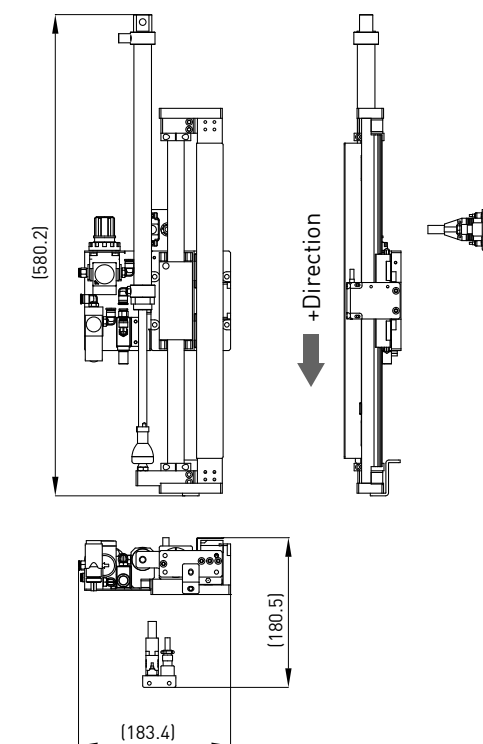

3.6 SLE series

- Integration of high-precision torque motor.
- Precision compensation and angular positioning.
- Simple structure, wide range of applications
- High stiffness extruded aluminum structure.
- High-speed, point-to-point motion.
- Can be equipped with ironless or ironcore motor.

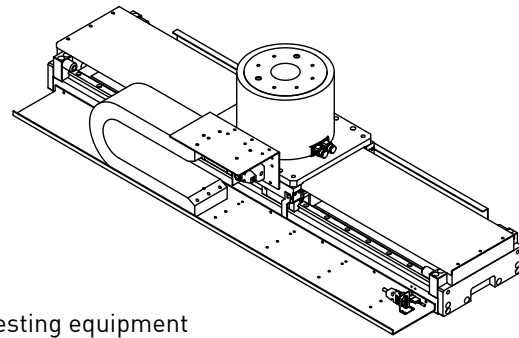

3.6.1 Industry applications

Automation equipment, touch panel coating equipment, AOI testing equipment

3.6.2 Performance specifications

Table3-5 LMX1C-S47-1-700+TMS34 product specification

Stage type	LMX1C-S47-1-700+TMS34
Motor Type	Ironcore(/Ironless) motor
Stroke(mm)	700
Peak Force(N)/Continuous Force(N)	1953/733
Repeatability(μm)	± 1(with HIWIN solution)
Accuracy(μm)	± 3(after error mapping)
Max. Acceleration(m/s ²)	10(with payload)
Max. Velocity(m/s)	1(with payload)
Payload(kg)	15
Stage orientation	Horizontal
Torque Motor Type	TMS34
Peak Torque(Nm)/Continuous Torque(Nm)	60/20
Max. Velocity(rpm)	500(220V)
Repeatability(arc-sec)	± 2.5
Accuracy(arc-sec)	± 25
Inertia of rotation parts(kgm ²)	0.02

Note : All specifications can be designed according to customer demand.

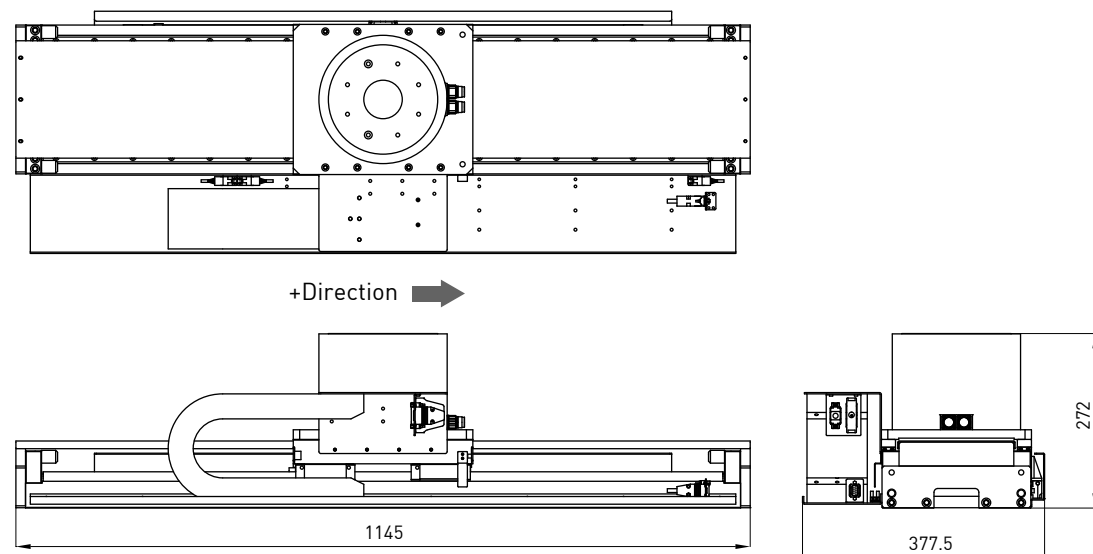

3.7 SBF series

- Vertical applications.
- High load capacity of up to 200 kg.
- Linear feedback system can be applied, high positioning accuracy, zero backlash.

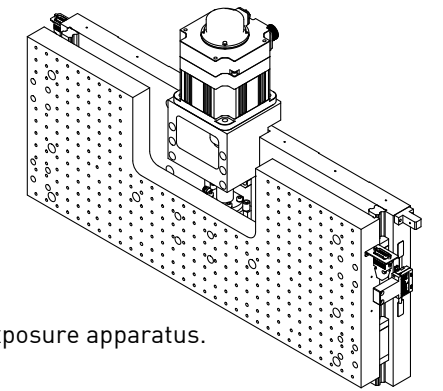

3.7.1 Industry applications

Automation equipment, touch panel coating equipment, AOI testing, exposure apparatus.

3.7.2 Performance specifications

Table3-6 BS-2-50 product specification

Stage type	BS-2-50
Motor Type	HIWIN AC Servo motor
Stroke(mm)	50
Ball screw lead(mm)	2
Repeatability(μm)	± 1(with HIWIN solution)
Accuracy(μm)	± 3(after error mapping)
Max. Acceleration(m/s ²)	2(with payload)
Max. Velocity(m/s)	0.05(with payload)
Horizontal Straightness(μm)	± 2
Vertical Straightness(μm)	± 10
Payload(kg)	200
Stage orientation	Vertical

Note : All specifications can be designed according to customer demand.

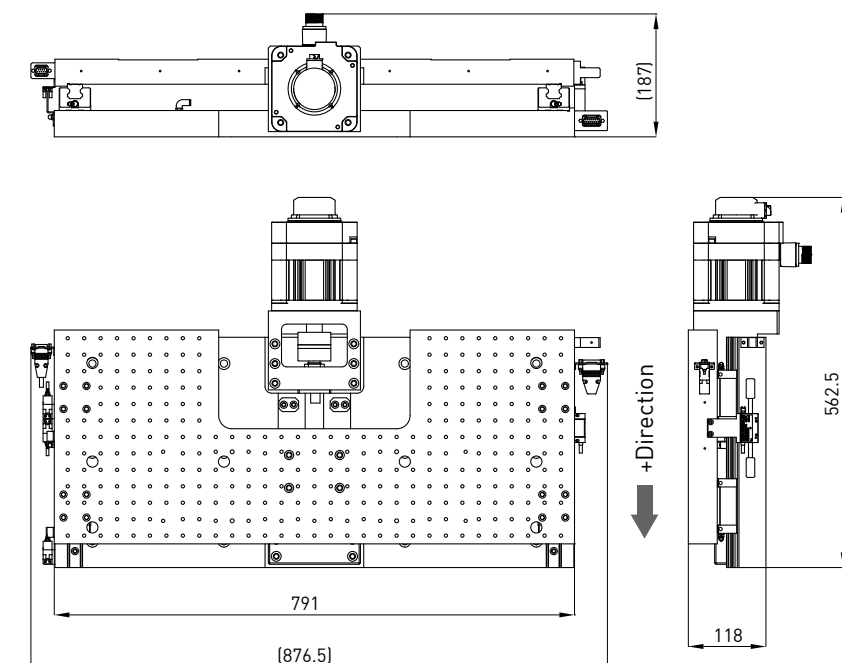

3.8 SBH series

- High stiffness oblique wedge structure.
- Vertically precision positioning.
- High load capacity.
- Large installation area, can be equipped with large-size vacuum chuck.

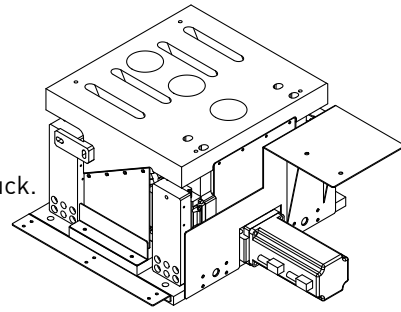

3.8.1 Industry applications

Exposure apparatus, the touch panel lamination equipment, laser cutting, AOI testing equipment.

3.8.2 Performance specifications

Table3-7 BS-2-12 product specification

Stage type	BS-2-12
Motor Type	HIWIN AC Servo motor
Stroke(mm)	12
Ball screw lead(mm)	2
Repeatability(μm)	± 2.5(uni-direction, with HIWIN solution)
Accuracy(μm)	± 10(uni-direction, after error mapping)
Max. Acceleration(m/s ²)	Vertical : 0.5, Horizontal : 0.87(with payload)
Max. Velocity(m/s)	Vertical : 0.02, Horizontal : 0.035(with payload)
Payload(kg)	35
Stage orientation	Horizontal

Note : All specifications can be designed according to customer demand.

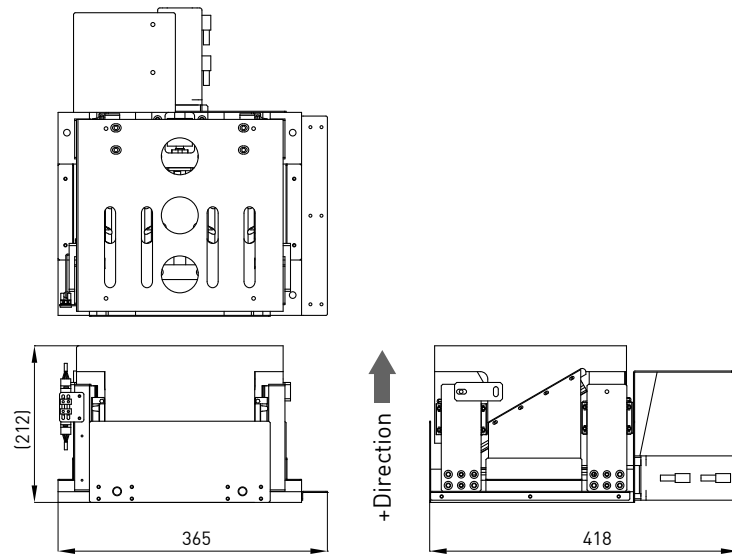

3.9 DLA series

- Integration of high-precision torque motor.
- XY positioning with high precision angular compensation.
- Use dust-proof design.
- High stiffness extruded aluminum structure.
- Can be equipped with ironless or ironcore motor.

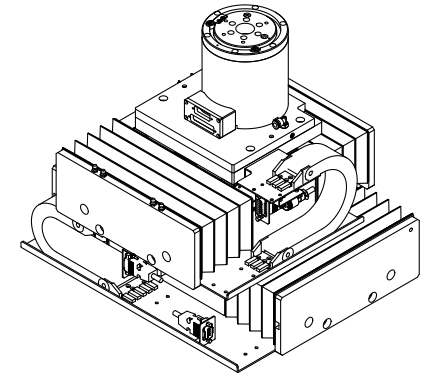

3.9.1 Industry applications

3D measuring equipment, glass substrate chamfering devices, glass substrate/PCB testing equipment.

3.9.2 Performance specifications

Table3-8 LMX2C-CB4CB7-50-50+TMS03 product specification

Stage type	LMX2C-CB4CB7-50-50+TMS03
Motor Type	Ironless(Ironcore) motor
Stroke(mm)	50
Peak Force(N)/Continuous Force(N)	X-axis : 512/128, Y-axis : 292/73
Repeatability(μm)	± 1(with HIWIN solution)
Accuracy(μm)	± 5(after error mapping)
Max. Acceleration(m/s ²)	X-axis : 5, Y-axis : 5(with payload)
Max. Velocity(m/s)	X-axis : 0.4, Y-axis : 0.2(with payload)
Payload(kg)	5
Stage orientation	Horizontal
Torque Motor Type	TMS03
Peak Torque(Nm)/Continuous Torque(Nm)	9.3/3.1
Max. Velocity(rpm)	500(220V)
Repeatability(arc-sec)	± 3
Accuracy(arc-sec)	± 45
Inertia of rotation parts(kg·m ²)	0.003

Note : All specifications can be designed according to customer demand.

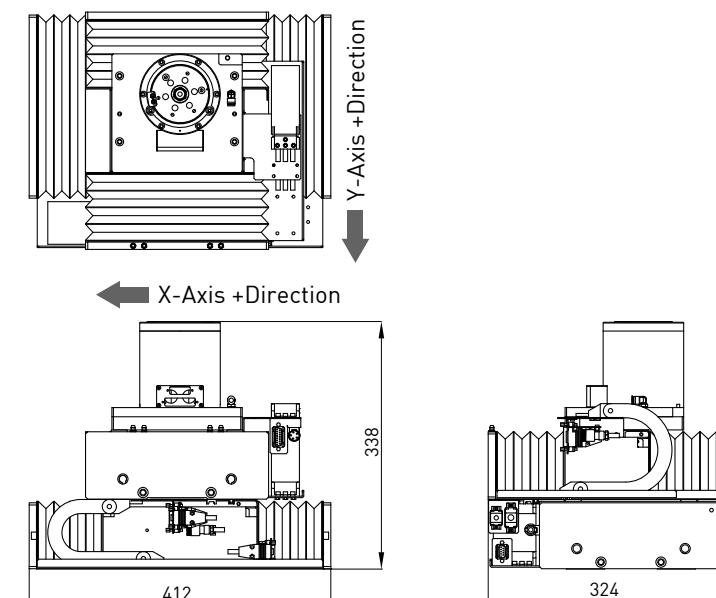

3.10 DLB series

- Upside down applications.
- Suitable for point-to-point motion.
- High stiffness extruded aluminum structure.
- Can be equipped with ironless or ironcore motor.
- Wide range of applications.

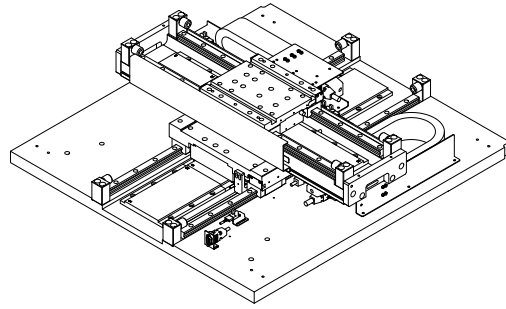

3.10.1 Industry applications

Automation equipment, AOI inspection applications, Wafer cutting applications, Wafer cutting applications.

3.10.2 Performance specifications

Table3-9 LMX2C-S23S47L-362-390 product specification

Stage type	LMX2C-S23S47L-362-390
Motor Type	Ironcore (/Ironless) motor
Stroke(mm)	X-axis : 362, Y-axis : 390
Peak Force(N)/Continuous Force(N)	X-axis : 639/240, Y-axis : 1953/733
Repeatability(μm)	±2(with HIWIN solution)
Accuracy(μm)	±4(after error mapping)
Max. Acceleration(m/s ²)	10(with payload)
Max. Velocity(m/s)	1(with payload)
Payload(kg)	10
Stage orientation	Upside down

Note : All specifications can be designed according to customer demand.

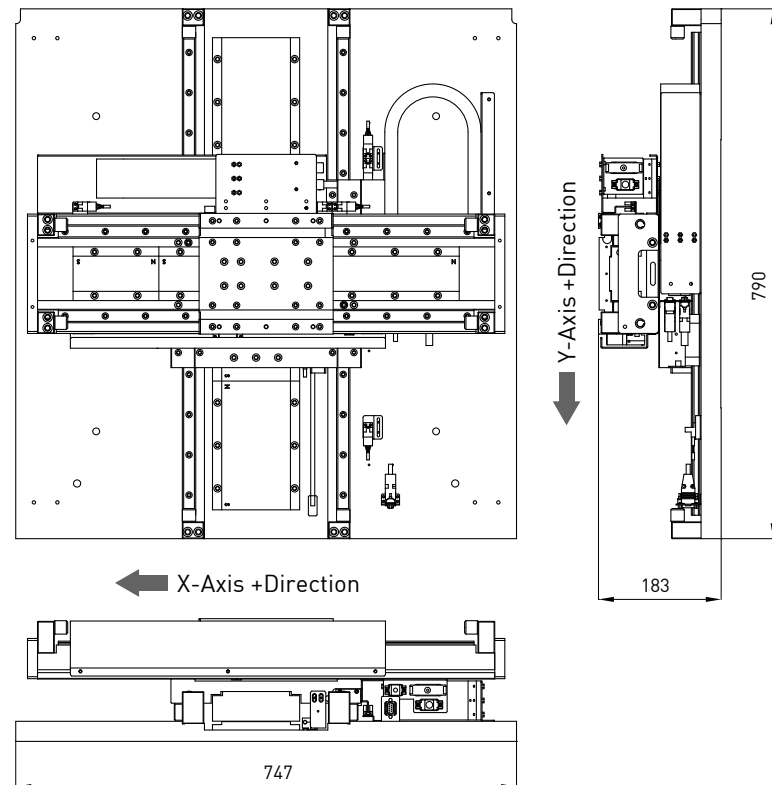

3.11 DLC series

- Suitable for High-speed scanning and rapid positioning motion.
- Simple structure and wide range of applications.

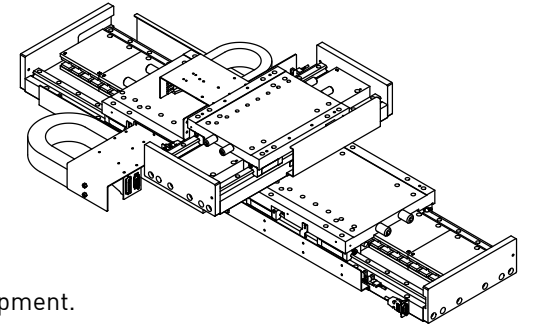

3.11.1 Industry applications

Biomedical testing equipment, electronic components plug-in equipment.

3.11.2 Performance specifications

Table3-10 LMX2C-CC8CFC-150-400 product specification

Stage type	LMX2C-CC8CFC-150-400
Motor Type	Ironless(/Ironcore) motor
Stroke(mm)	X-axis : 150, Y-axis : 400
Peak Force(N)/Continuous Force(N)	X-axis : 780/195, Y-axis : 2736/684
Repeatability(μm)	±2(with HIWIN solution)
Accuracy(μm)	±5(after error mapping)
Max. Acceleration(m/s ²)	X-axis : 10, Y-axis : 10(with payload)
Max. Velocity(m/s)	X-axis : 1, Y-axis : 1(with payload)
Payload(kg)	10
Stage orientation	Horizontal

Note : All specifications can be designed according to customer demand.

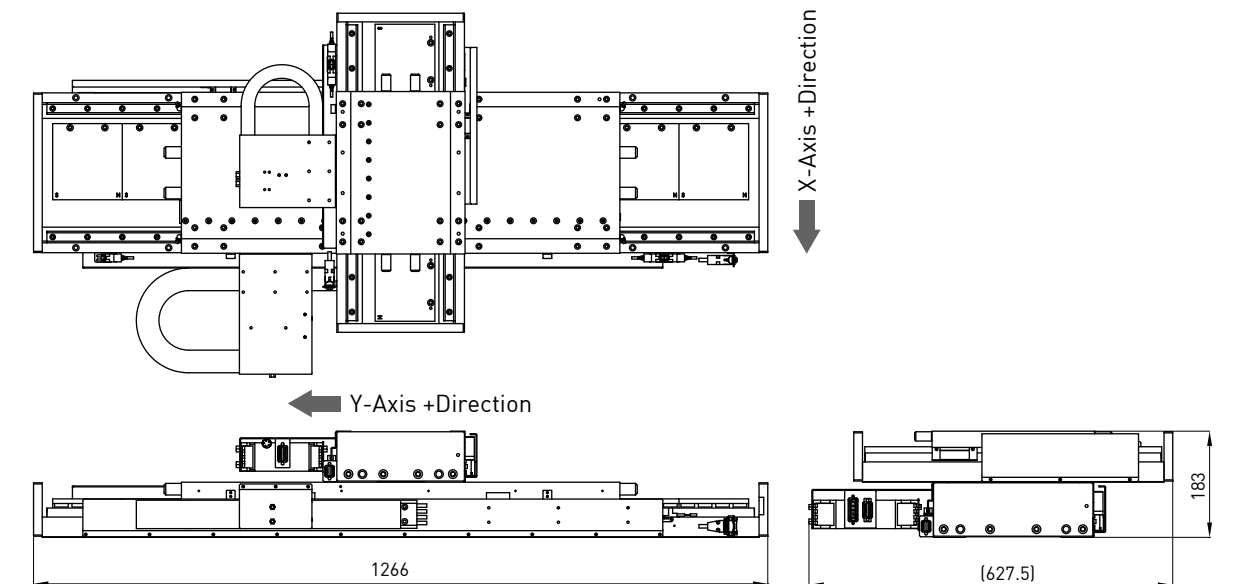

3.12 DLD series

- Suitable for point-to-point motion.
- Vertical straightness up to $\pm 4 \mu\text{m}$.
- Use dust-proof design.
- High load capacity.
- Simple structure and wide range of applications.

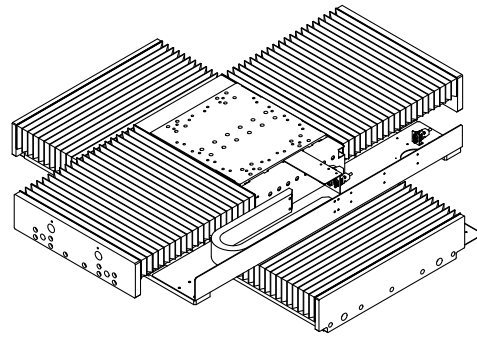

3.12.1 Industry applications

PCB/steel plate laser cutting applications, automation equipment, and 3D engraving machine applications.

3.12.2 Performance specifications

Table3-11 LMX2C-S37S67L-600-600 product specification

Stage type	LMX2C-S37S67L-600-600
Motor Type	Ironcore (/Ironless) motor
Stroke(mm)	X-axis : 600, Y-axis : 600
Peak Force(N)/Continuous Force(N)	X-axis : 1425/535, Y-axis : 2850/1069
Repeatability(μm)	± 2 (with HIWIN solution)
Accuracy(μm)	± 3 (after error mapping)
Max. Acceleration(m/s^2)	X-axis : 10, Y-axis : 7(with payload)
Max. Velocity(m/s)	0.7(with payload)
Vertical Straightness(μm)	X-axis : ± 4 , Y-axis : ± 5
Orthogonality(arc-sec)	± 5
Payload(kg)	35
Stage orientation	Horizontal

Note : All specifications can be designed according to customer demand.

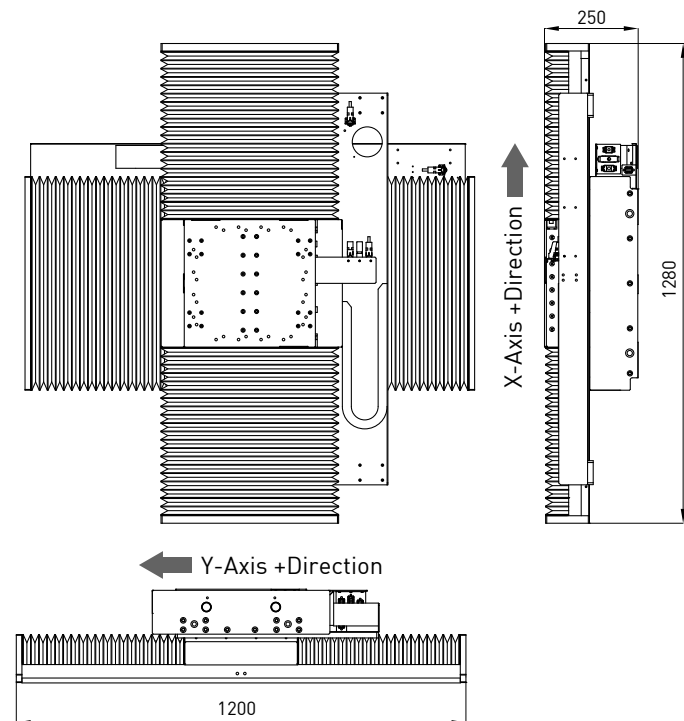

3.13 DLE series

- Integration of high-precision torque motor.
- X-Y positioning with high precision angular compensation.
- High stiffness extruded aluminum structure.
- Best guideway supporting structure design.

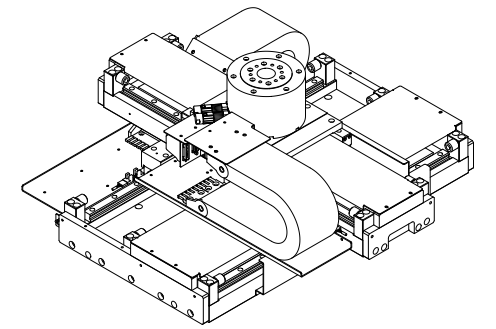

3.13.1 Industry applications

Automation equipment, AOI testing equipment, laser cutting applications, appearance grinding trimming equipment.

3.13.2 Performance specifications

Table3-12 LMX2C-S27S47-300-300+TMS12 product specification

Stage type	LMX2C-S27S47-300-300+TMS12
Motor Type	Ironcore (/Ironless) motor
Stroke(mm)	X-axis : 300, Y-axis : 300
Peak Force(N)/Continuous Force(N)	X-axis : 1953/733, Y-axis : 1017/382
Repeatability(μm)	± 0.5 (with HIWIN solution)
Accuracy(μm)	± 1 (after error mapping)
Max. Acceleration(m/s^2)	5(with payload)
Max. Velocity(m/s)	0.8(with payload)
Orthogonality(arc-sec)	± 5
Payload(kg)	40
Stage orientation	Horizontal
Torque Motor Type	TMS12
Peak Torque(Nm)/Continuous Torque(Nm)	15/5
Max. Velocity(rpm)	700(220V)
Repeatability(arc-sec)	± 3
Accuracy(arc-sec)	± 45
Inertia of rotation parts(kgm^2)	0.006

Note : All specifications can be designed according to customer demand.

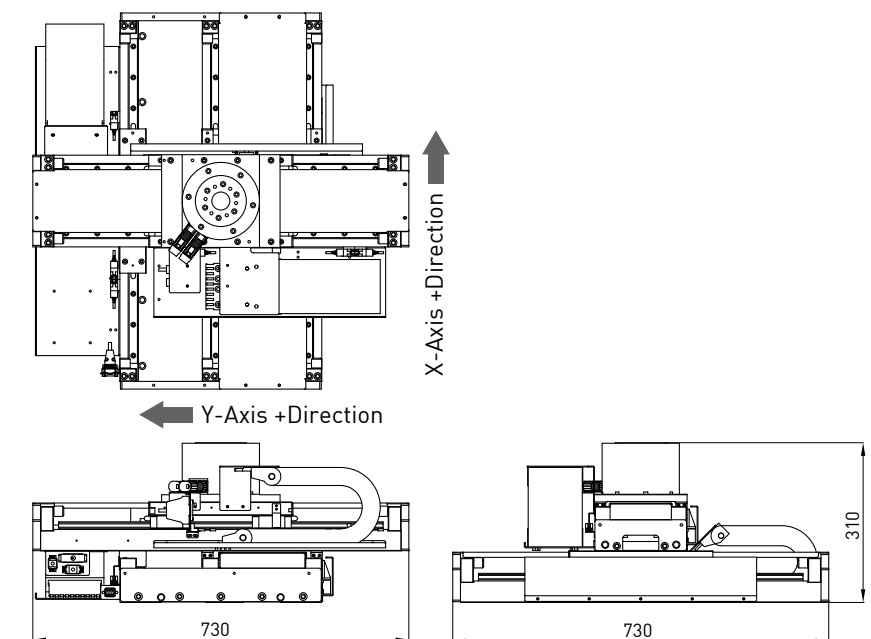

3.14 DLF series

- Stainless steel cover, can withstand Instantaneous high temperature.
- Maze dust-proof design.
- With short setting time.
- Low center of gravity design.
- Equipped with ironless motor.

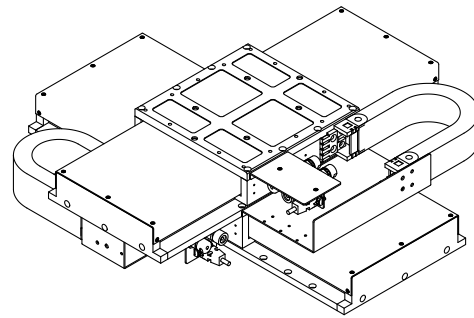

3.14.1 Industry applications

Automation equipment, laser cutting equipment.

3.14.2 Performance specifications

Table3-13 LMX2C-CB7CC7-280-340 product specification

Stage type	LMX2C-CB7CC7-280-340
Motor Type	Ironless motor
Stroke(mm)	X-axis : 280, Y-axis : 340
Peak Force(N)/Continuous Force(N)	X-axis : 512/128, Y-axis : 684/171
Repeatability(μm)	±3(with HIWIN solution)
Accuracy(μm)	±5(after error mapping)
Max. Acceleration(m/s ²)	X-axis : 10, Y-axis : 5(with payload)
Max. Velocity(m/s)	X-axis : 0.7, Y-axis : 0.5(with payload)
Orthogonality(arc-sec)	±5
Payload(kg)	35
Stage orientation	Horizontal

Note : All specifications can be designed according to customer demand.

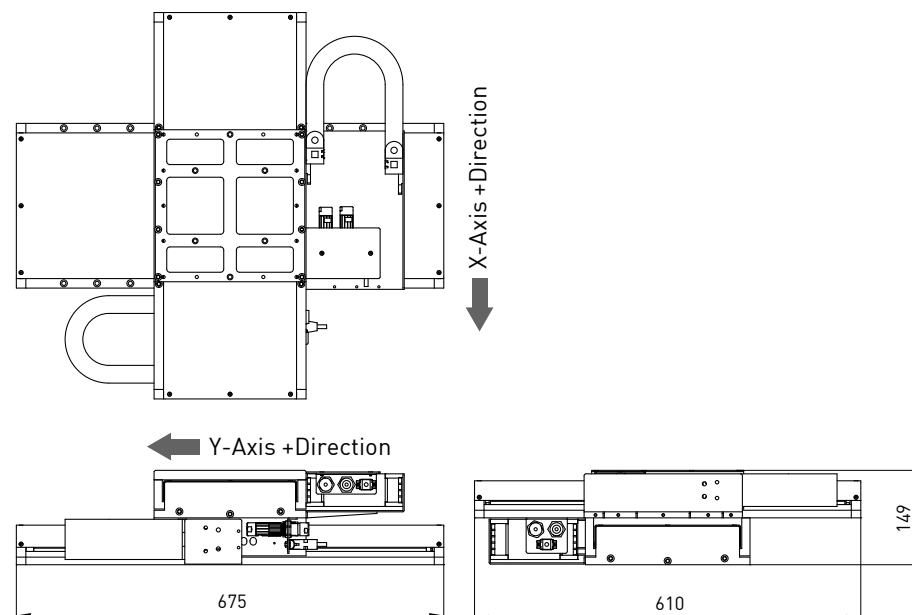

3.15 DLG series

- Sealed architecture.
- Suitable for the high dust environment.
- Low center of gravity design.
- With short setting time.
- Equipped with ironless motor.

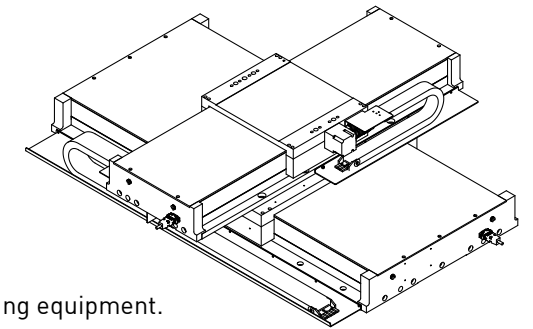

3.15.1 Industry applications

Automation equipment, laser cutting equipment, PCB drilling equipment.

3.15.2 Performance specifications

Table3-14 LMX2C-CE4CE6-2-450-500 product specification

Stage type	LMX2C-CE4CE6-2-450-500
Motor Type	Ironless motor
Stroke(mm)	X-axis : 500, Y-axis : 450
Peak Force(N)/Continuous Force(N)	X-axis : 1104/276, Y-axis : 736/184
Repeatability(μm)	±1(with HIWIN solution)
Accuracy(μm)	±1.5(after error mapping)
Max. Acceleration(m/s ²)	5(with payload)
Max. Velocity(m/s)	0.22(with payload)
Payload(kg)	35
Stage orientation	Horizontal

Note : All specifications can be designed according to customer demand.

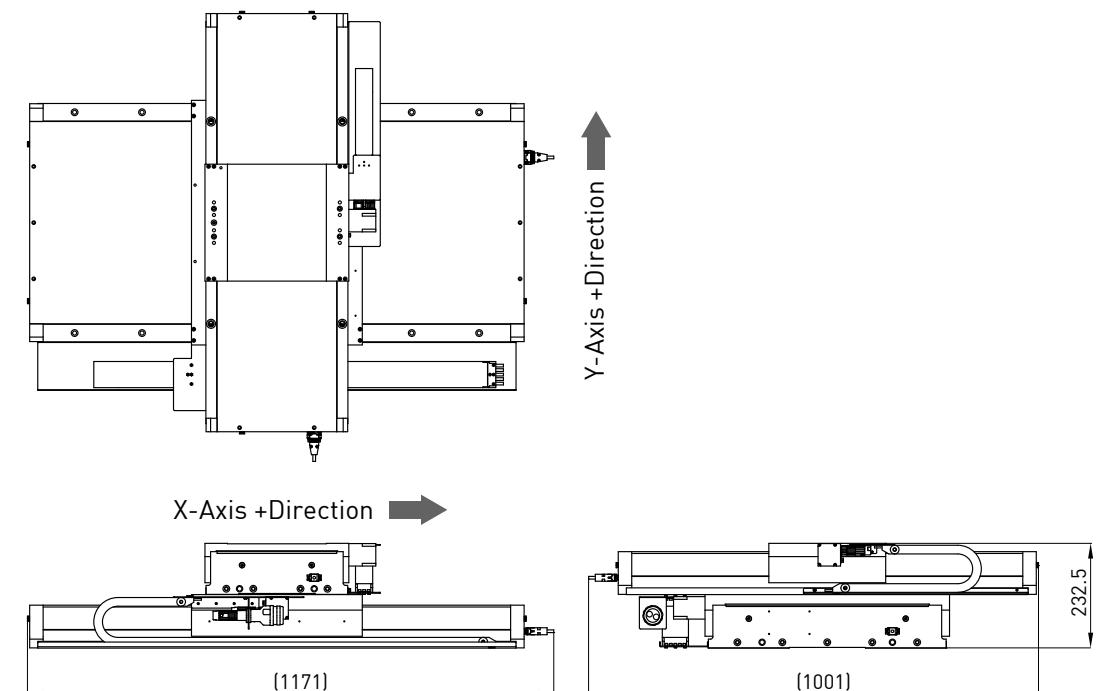

3.16 DLH series

- Suitable for vacuum environment, 1×10^{-6} Torr.
- Vacuum flat cable.
- Integration of high-precision torque motor.
- X-Y positioning with high precision angular compensation.
- Can be equipped with ironless or ironcore motor.

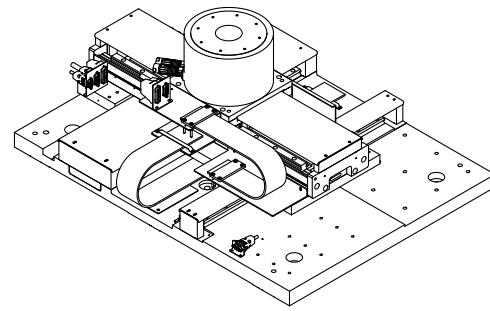

3.16.1 Industry applications

Automation equipment, plasma repair equipment, electron beam scanning applications.

3.16.2 Performance specifications

Table3-15 LMX2C-S23S27-360-240+TMS32 product specification

Stage type	LMX2C-S23S27-360-240+TMS32
Motor Type	Ironcore (/Ironless) motor
Stroke(mm)	X-axis : 240, Y-axis : 360
Peak Force(N)/Continuous Force(N)	X-axis : 1017/382, Y-axis : 639/240
Repeatability(μm)	X-axis : ± 2 , Y-axis : ± 1 (with HIWIN solution)
Accuracy(μm)	X-axis : ± 5 , Y-axis : ± 3 (after error mapping)
Max. Acceleration(m/s^2)	X-axis : 5, Y-axis : 5(with payload)
Max. Velocity(m/s)	X-axis : 0.7, Y-axis : 1(with payload)
Payload(kg)	5
Stage orientation	Horizontal
Torque Motor Type	TMS32
Peak Torque(Nm)/Continuous Torque(Nm)	30/10
Max. Velocity(rpm)	700(220V)
Repeatability(arc-sec)	± 3
Accuracy(arc-sec)	± 15
Inertia of rotation parts(kgm^2)	0.014

Note : All specifications can be designed according to customer demand.

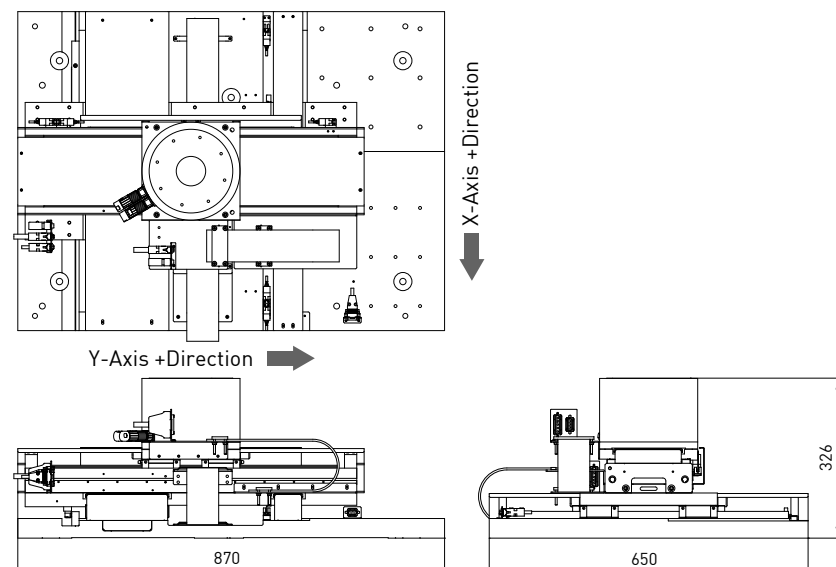

3.17 DLJ series

- Integration of high-precision torque motor.
- XY positioning with high precision angular compensation.
- Low center of gravity design.
- With short setting time.
- Excellent servo stability.
- Use low dust flat cable(class 1).
- Can be equipped with ironless or ironcore motor.

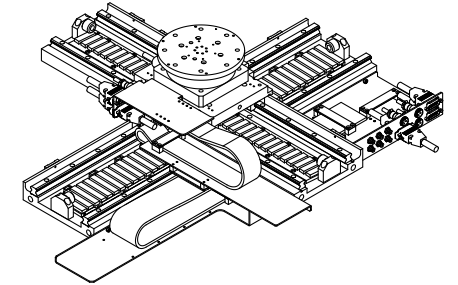

3.17.1 Industry applications

The semiconductor wafer inspection equipment, AOI equipment.

3.17.2 Performance specifications

Table3-16 LMX2C-SA11LSA21L-420-490+TMF42 product specification

Stage type	LMX2C-SA11LSA21L-420-490+TMF42
Motor Type	Ironcore (/Ironless) motor
Stroke(mm)	X-axis : 420, Y-axis : 490
Peak Force(N)/Continuous Force(N)	X-axis : 254/90, Y-axis : 462/149
Repeatability(μm)	± 0.5 (with HIWIN solution)
Accuracy(μm)	± 2 (after error mapping)
Max. Acceleration(m/s^2)	6.5(with payload)
Max. Velocity(m/s)	0.5(with payload)
Vertical Straightness(μm)	± 10
Orthogonality(arc-sec)	± 5
Payload(kg)	10
Stage orientation	Horizontal
Torque Motor Type	TMF42
Peak Torque(Nm)/Continuous Torque(Nm)	3.6/1.2
Max. Velocity(rpm)	120(220V)
Repeatability(arc-sec)	± 2.5
Accuracy(arc-sec)	± 25
Inertia of rotation parts(kgm^2)	0.0005

Note : All specifications can be designed according to customer demand.

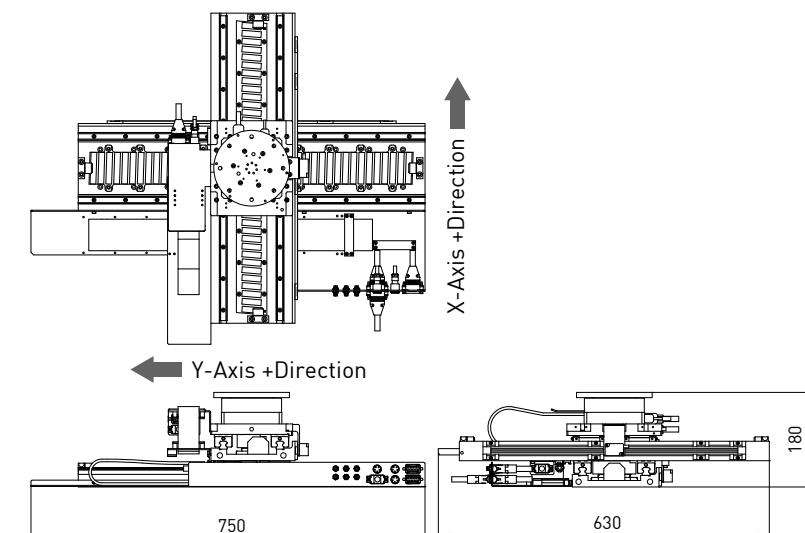

3.18 DLK series

- Multi-forcer simultaneously motion.
- Suitable for laterally applications.
- For high-speed reciprocating motion.
- Z-axis using a linear motor with a pneumatic counterweight design.
- With high speed and high accuracy.
- Can be equipped with ironless or ironcore motor.

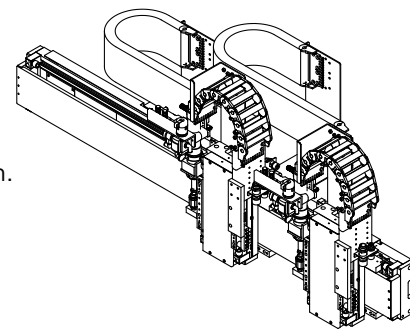

3.18.1 Industry applications

Solar automation equipment, high-speed pick and place feeding equipment, electronic components assembly equipment.

3.18.2 Performance specifications

Table3-17 LMX4C-S13S37-2-32-750 product specification

Stage type	LMX4C-S13S37-2-32-750
Motor Type	Ironcore (/Ironless) motor
Stroke(mm)	Z-axis : 32, Y-axis : 750
Peak Force(N)/Continuous Force(N)	Z-axis : 540/203, Y-axis : 1425/535
Repeatability(μm)	±2(with HIWIN solution)
Accuracy(μm)	±5(after error mapping)
Max. Acceleration(m/s ²)	Z-axis : 10, Y-axis : 10(with payload)
Max. Velocity(m/s)	Z-axis : 0.5, Y-axis : 1.3(with payload)
Payload(kg)	10
Stage orientation	Laterally

Note : All specifications can be designed according to customer demand.

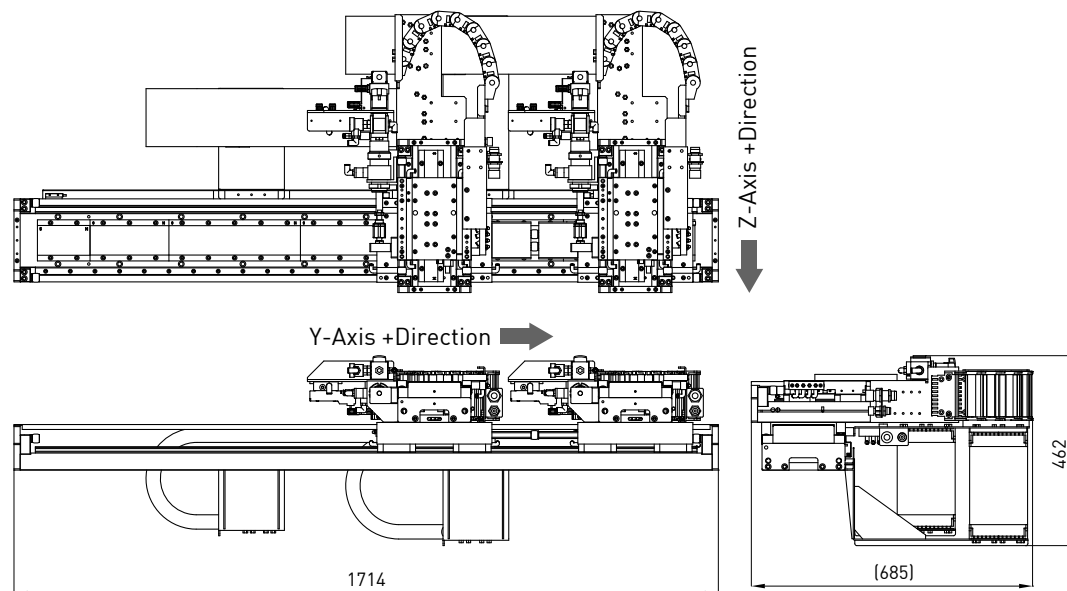

3.19 RLA series

- Fully enclosed waterproof design.
- Using non-contact air bearing.
- XY cantilever structure.
- Space saving.
- Lightweight and high-stiffness design.
- Can be equipped with ironless or ironcore motor.

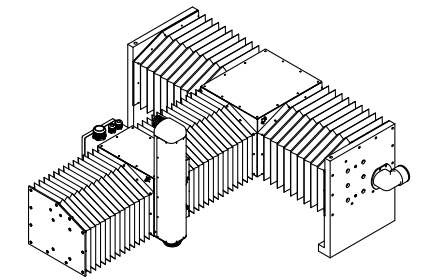

3.19.1 Industry applications

Waterjet equipment, laser cutting equipment, automation equipment.

3.19.2 Performance specifications

Table3-18 LMX2C-S13S17-510-510 product specification

Stage type	LMX2C-S13S17-510-510
Motor Type	Ironcore (/Ironless) motor
Stroke(mm)	X-axis : 510, Y-axis : 510
Peak Force(N)/Continuous Force(N)	X-axis : 540/203, Y-axis : 609/228
Repeatability(μm)	X-axis : ±2, Y-axis : ±2(with HIWIN solution)
Accuracy(μm)	X-axis : ±5, Y-axis : ±5(after error mapping)
Max. Acceleration(m/s ²)	X-axis : 10, Y-axis : 5(with payload)
Max. Velocity(m/s)	X-axis : 0.8, Y-axis : 0.5(with payload)
Payload(kg)	10
Stage orientation	Horizontal

Note : All specifications can be designed according to customer demand.

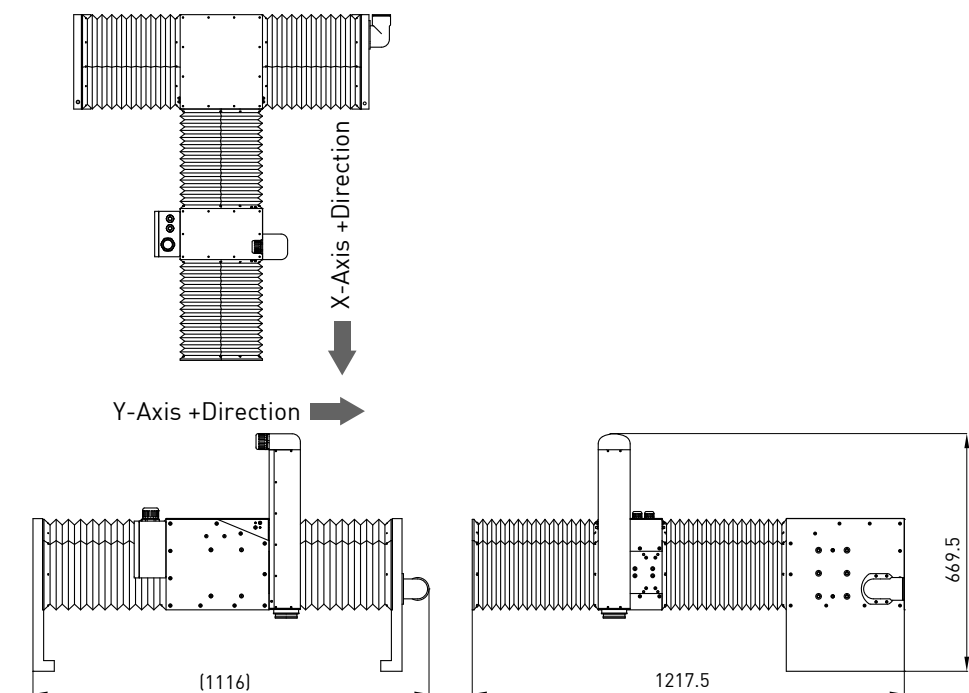

3.20 RLB series

- Z-axis counterweight design.
- Excellent low speed velocity stability $\pm 1\%$ @10 mm/s.
- Fully enclosed waterproof design.
- High positioning accuracy up to $\pm 1\ \mu\text{m}$.
- Can be equipped with ironless or ironcore motor.

3.20.1 Industry applications

Micromachining equipment, 3D measurement equipment, 3D engraving equipment.

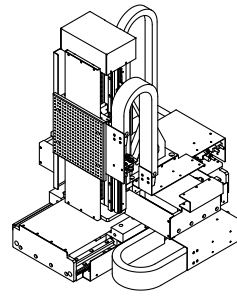

3.20.2 Performance specifications

Table3-19 LMX3C-CB5CB5CB8-200-200-200 product specification

Stage type	LMX3C-CB5CB5CB8-200-200-200
Motor Type	Ironless(/Ironcore) motor
Stroke(mm)	X-axis : 200, Y-axis : 200, Z-axis : 200
Peak Force(N)/Continuous Force(N)	X-axis : 580/145, Y-axis : 364/91, Z-axis : 364/91
Repeatability(μm)	± 0.5 (with HIWIN solution)
Accuracy(μm)	± 1 (after error mapping)
Max. Acceleration(m/s^2)	X-axis : 0.5, Y-axis : 0.5, Z-axis : 0.5(with payload)
Max. Velocity(m/s)	X-axis : 0.2, Y-axis : 0.2, Z-axis : 0.05(with payload)
Orthogonality(arc-sec)	X-Y : ± 4 , Y-Z : ± 2 , X-Z : ± 3
Speed ripple	X-axis : 1.35, Y-axis : 0.93, Z-axis : 1.57(when V=5mm/s)
Payload(kg)	5
Stage orientation	Horizontal

Note : All specifications can be designed according to customer demand.

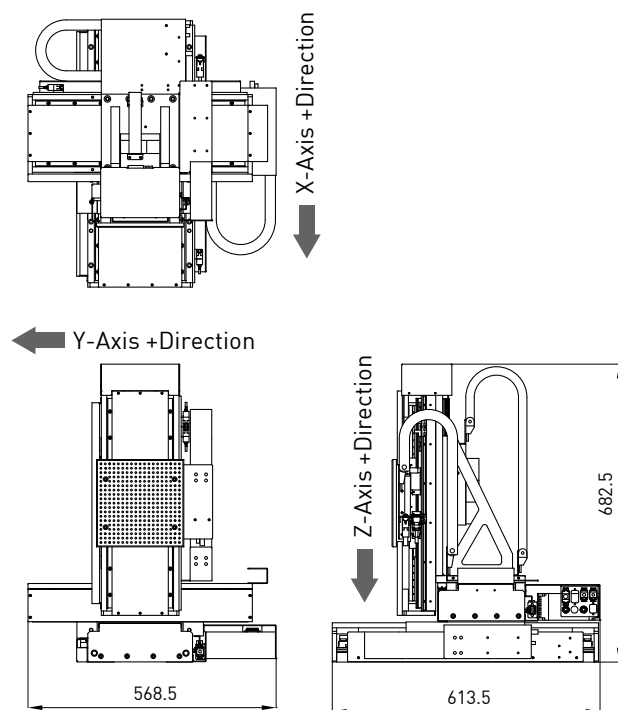

3.21 RBC series

- Z-axis designed with KK series ballscrew driven stage module significantly reduces system cost.
- Use dust-proof design.
- Three-dimensional motion.
- Simple structure design.

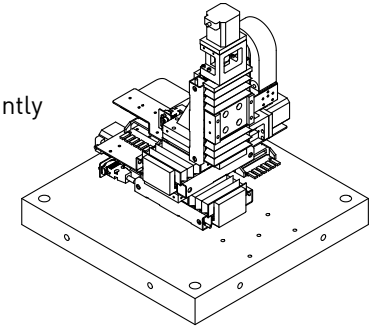

3.21.1 Industry applications

Mechanical component testing equipment, automation equipment, 3D engraving equipment.

3.21.2 Performance specifications

Table3-20 KK6010-KK6010-KK6005-150-150-150 product specification

Stage type	KK6010-KK6010-KK6005-150-150-150
Motor Type	HIWIN AC Servo motor
Stroke(mm)	X-axis : 55, Y-axis : 55, Z-axis : 55
Ball screw lead(mm)	X-axis : 10, Y-axis : 10, Z-axis : 5
Repeatability(μm)	± 2 (uni-direction, with HIWIN solution)
Accuracy grade	C
Max. Acceleration(m/s^2)	X-axis : 5, Y-axis : 5, Z-axis : 5(HIWIN 100W, with payload)
Max. Velocity(m/s)	X-axis : 0.5, Y-axis : 0.5, Z-axis : 0.2(HIWIN 100W, with payload)
Payload(kg)	1
Stage orientation	Horizontal

Note : All specifications can be designed according to customer demand.

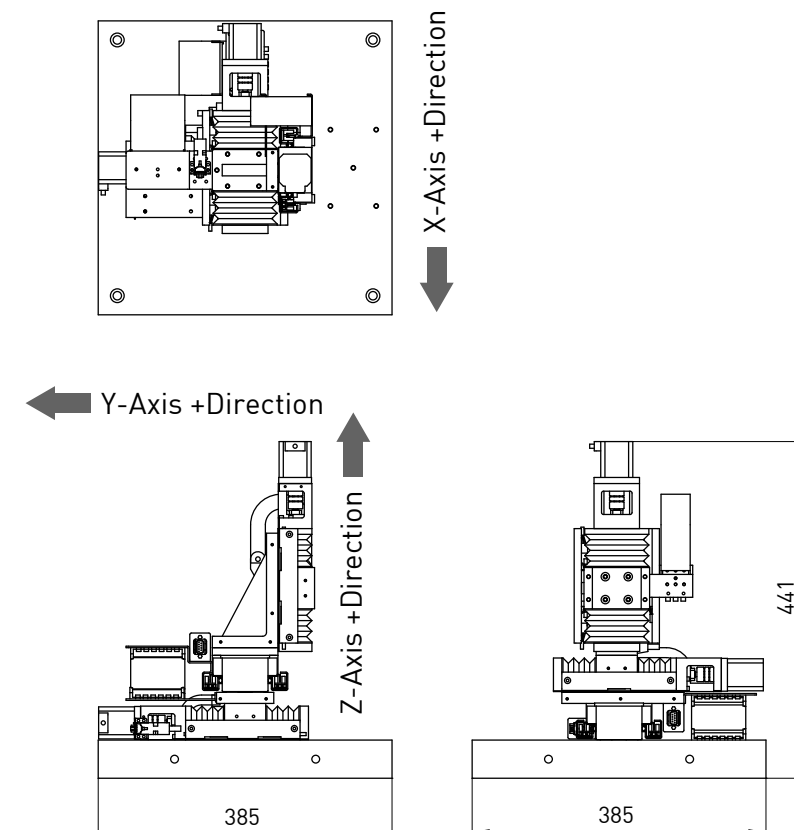

3.22 GLA series

- Micro gantry structure.
- Space saving.
- Lightweight beam design.
- High dynamic response.
- Can be equipped with ironless or ironcore motor.

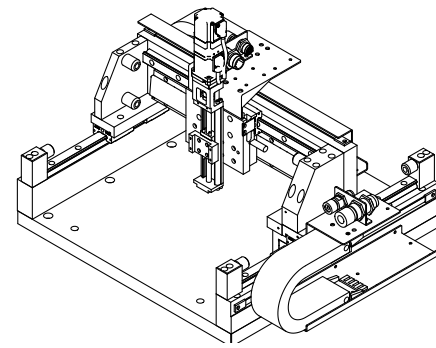

3.22.1 Industry applications

Electronic components assembly equipment, biomedical equipment industries, AOI testing equipment.

3.22.2 Performance specifications

Table3-21 LMG2C-S11S11-200-200+KK4005C-150A1-F2M product specification	
Stage type	LMG2C-S11S11-200-200+KK4005C-150A1-F2M
Motor Type	Ironcore (/Ironless) motor & HIWIN AC Servo motor
Stroke(mm)	X-axis : 200, Y-axis : 200, Z-axis : 50
Peak Force(N)/Continuous Force(N)	X-axis : 254/92, Y-axis : 254/92, Z-axis : HIWIN 50W(220V)
Ball screw lead(mm)	Z-axis : 5
Repeatability(μm)	X-axis : ±2, Y-axis : ±3, Z-axis : ±2(uni-direction, with HIWIN solution)
Accuracy(μm)	X-axis : ±5, Y-axis : ±10, Z-axis : ±10(uni-direction, after error mapping)
Max. Acceleration(m/s ²)	X-axis : 5, Y-axis : 5, Z-axis : 5(with payload)
Max. Velocity(m/s)	X-axis : 1, Y-axis : 0.5, Z-axis : 0.04(with payload)
Payload(kg)	1
Stage orientation	Horizontal
Note : All specifications can be designed according to customer demand.	

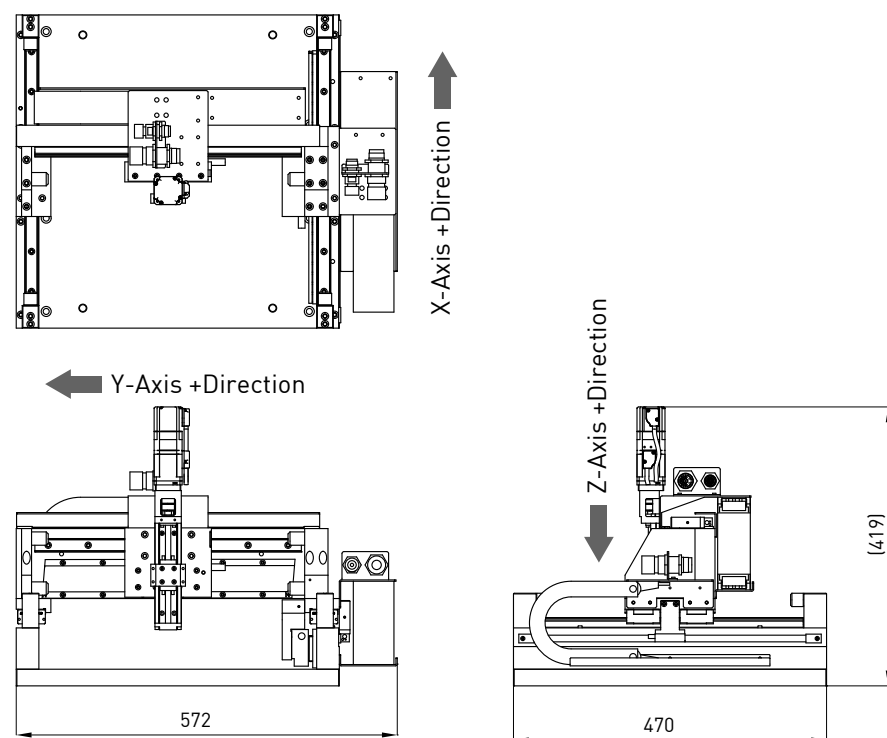

3.23 GLB series

- High stiffness aluminum gantry structure.
- Use dust-proof design.
- Z-axis designed with KK series ballscrew driven stage module.
- Unilateral or bilateral drive structure are seletable according to the precision requirement.
- Can be equipped with ironless or ironcore motor.

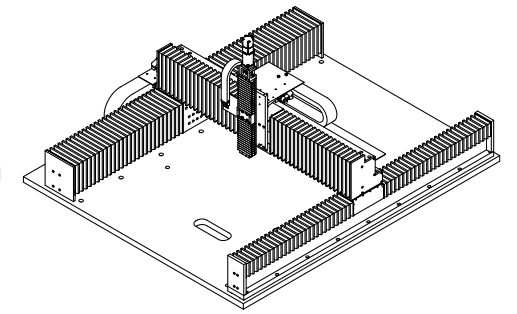

3.23.1 Industry applications

Automation industrial equipment, laser cutting applications, spraying equipment

3.23.2 Performance specifications

Table3-22 LMG2A-S13S23-600-900+KK6005C-400A1-F2BS2M product specification	
Stage type	LMG2A-S13S23-600-900+KK6005C-400A1-F2BS2M
Motor Type	Ironcore (/Ironless) motor & HIWIN AC Servo motor
Stroke(mm)	X-axis : 600, Y-axis : 900, Z-axis : 234
Peak Force(N)/Continuous Force(N)	X-axis : 540/203, Y-axis : 639/240, Z-axis : HIWIN 100W(220V)
Ball screw lead(mm)	Z-axis : 5
Repeatability(μm)	X-axis : ±5, Y-axis : ±5, Z-axis : ±2(uni-direction, with HIWIN solution)
Accuracy(μm)	X-axis : ±15, Y-axis : ±15, Z-axis : C(uni-direction, after error mapping)
Max. Acceleration(m/s ²)	5(with payload)
Max. Velocity(m/s)	0.2(with payload)
Payload(kg)	5
Stage orientation	Horizontal
Note : All specifications can be designed according to customer demand.	

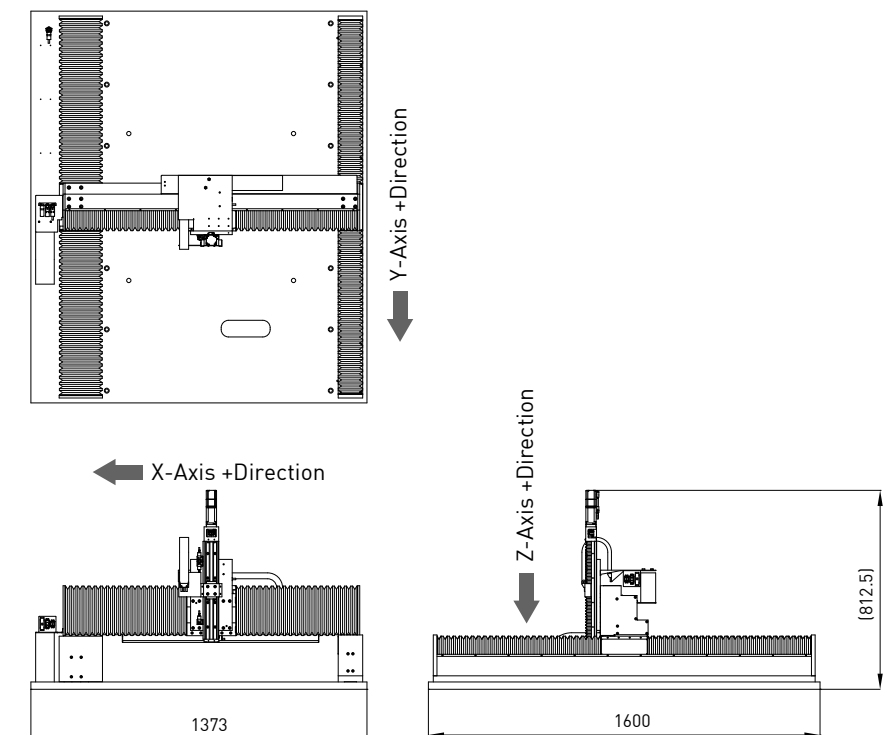

3.24 GLD series

- High stiffness cast iron base.
- With excellent vibration suppression capability.
- Suitable for high acceleration and deceleration applications.
- With excellent positioning accuracy.
- Unilateral or bilateral drive structure are seletable according to the precision requirement.

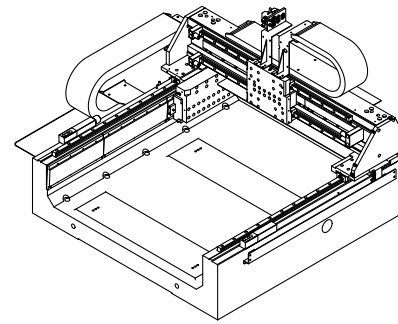

3.24.1 Industry applications

Automation equipment, PCB AOI inspection applications.

3.24.2 Performance specifications

Table3-23 LMG2C-S13S37L-515-540 product specification

Stage type	LMG2C-S13S37L-515-540
Motor Type	Ironcore (/Ironless) motor
Stroke(mm)	X-axis : 515, Y-axis : 540
Peak Force(N)/Continuous Force(N)	X-axis : 540/203, Y-axis : 1425/535
Repeatability(μm)	±1(uni-direction, with HIWIN solution)
Accuracy(μm)	±2(after error mapping)
Max. Acceleration(m/s ²)	X-axis : 15, Y-axis : 10(with payload)
Max. Velocity(m/s)	X-axis : 1.5, Y-axis : 1.5(with payload)
Vertical Straightness(μm)	10
Horizontal Straightness(μm)	10
Pitch(arc-sec)	25
Yaw(arc-sec)	X-axis : 20, Y-axis : 15
Orthogonality(arc-sec)	±5
Payload(kg)	12
Stage orientation	Horizontal

Note : All specifications can be designed according to customer demand.

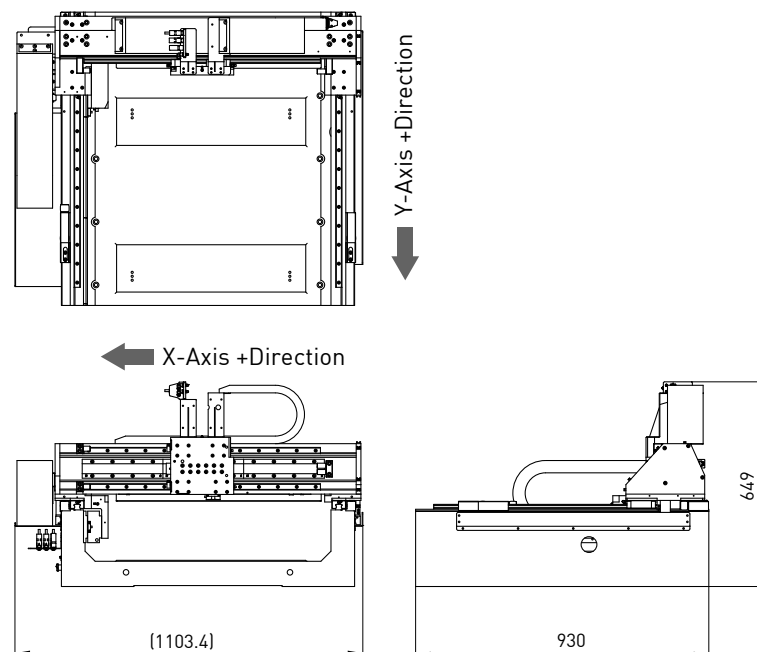

3.25 GLE series

- High stiffness aluminum gantry structure.
- Suitable for high acceleration and deceleration applications.
- Maximize the working area.
- Space saving.
- Can be equipped with ironless or ironcore motor.

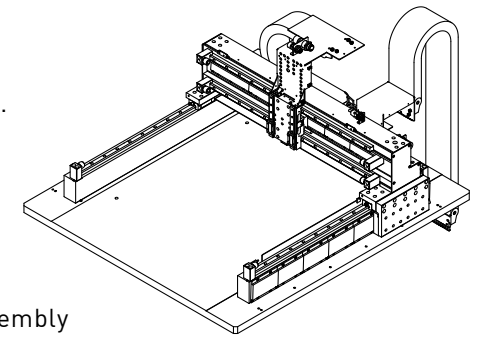

3.25.1 Industry applications

Automation equipment, electronic components plug-in assembly equipment, AOI equipment, automatic coating equipment

3.25.2 Performance specifications

Table3-24 LMG2C-SA11SA22-580-500 product specification

Stage type	LMG2C-SA11SA22-580-500
Motor Type	Ironcore (/Ironless) motor
Stroke(mm)	X-axis : 580, Y-axis : 500
Peak Force(N)/Continuous Force(N)	X-axis : 289/121, Y-axis : 1023/426
Repeatability(μm)	±2.5(uni-direction, with HIWIN solution)
Accuracy(μm)	±5(after error mapping)
Max. Acceleration(m/s ²)	X-axis : 10, Y-axis : 10(with payload)
Max. Velocity(m/s)	X-axis : 0.5, Y-axis : 0.5(with payload)
Vertical Straightness(μm)	±5
Horizontal Straightness(μm)	±5
Payload(kg)	5
Stage orientation	Horizontal

Note : All specifications can be designed according to customer demand.

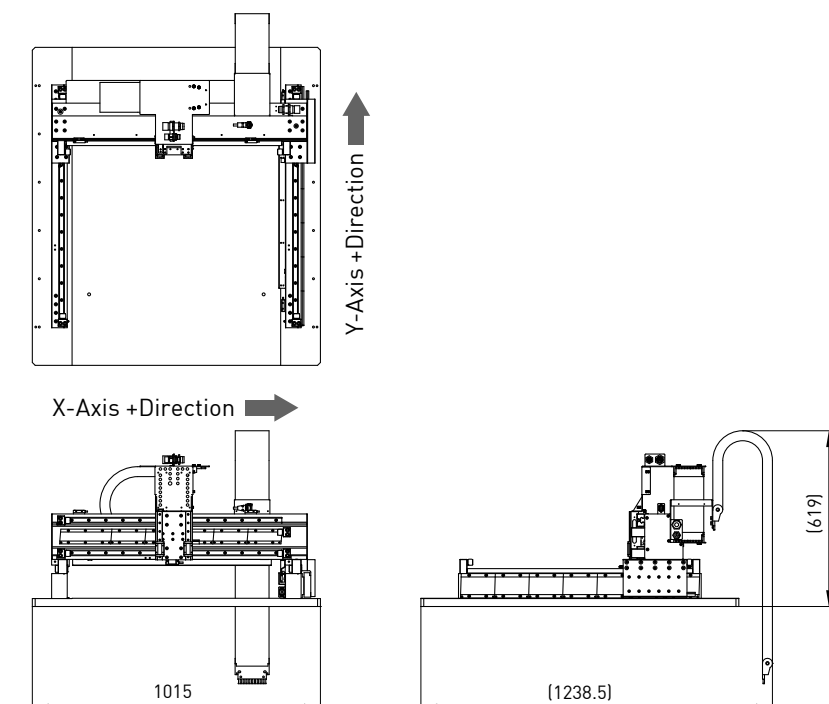

3.26 GLF series

- Use dust-proof design.
- Granite base, Steel beams.
- Modular Z-axis with a high-precision torque motor.
- Can be equipped with ironless or ironcore motor.

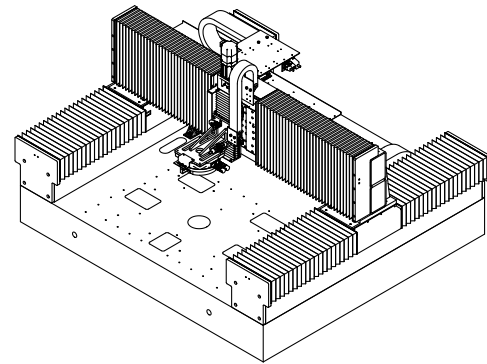

3.26.1 Industry applications

Optical detection applications, 3D measurement system

3.26.2 Performance specifications

Table3-25 LMG3C-S47LS37L-750-550 +KK8610P-340A1-F0BS2M+TMN71EH product specification

Stage type	LMG3C-S47LS37L-750-550 +KK8610P-340A1-F0BS2M+TMN71EH
Motor Type	Ironcore (/Ironless) motor & HIWIN AC Servo motor
Stroke(mm)	X-axis : 750, Y-axis : 550, Z-axis : 170
Peak Force(N)/Continuous Force(N)	X-axis : 1953/733, Y-axis : 1425/535, Z-axis : HIWIN 400W
Repeatability(μm)	X-axis : ±1, Y-axis : ±1, Z-axis : ±2(with HIWIN solution)
Accuracy(μm)	±3(after error mapping)
Max. Acceleration(m/s ²)	X-axis : 20, Y-axis : 4, Z-axis : 2.5(with payload)
Max. Velocity(m/s)	X-axis : 1, Y-axis : 1, Z-axis : 0.5(with payload)
Payload(kg)	5
Stage orientation	Horizontal
Torque Motor Type	TMN71EH
Peak Torque(Nm)/Continuous Torque(Nm)	11.1/3.7
Max. Velocity(rpm)	600(220V)
Repeatability(arc-sec)	±2.5
Accuracy(arc-sec)	±10
Inertia of rotation parts(kgm ²)	0.008

Note : All specifications can be designed according to customer demand.

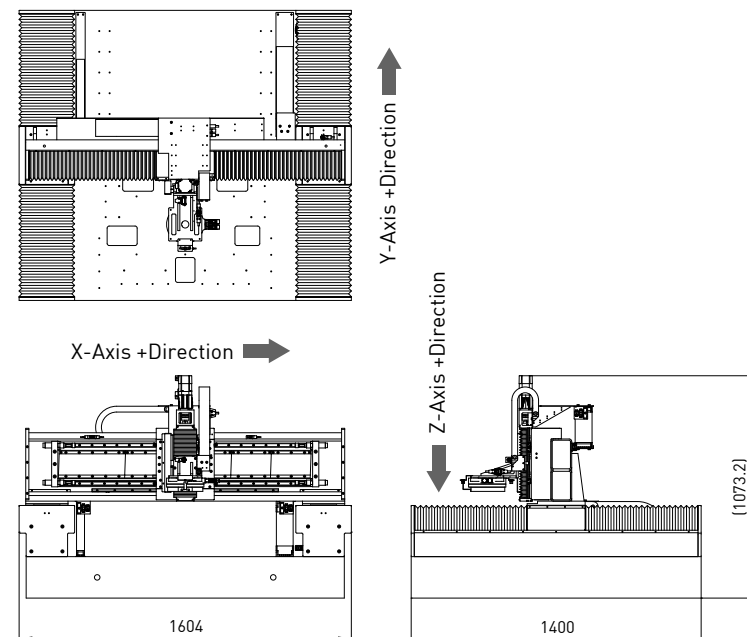

3.27 GBC series

- Ballscrew structure.
- High acceleration and deceleration motion.
- Can be equipped with linear scale to enhance the positioning accuracy and reproducibility.
- Simple structure.

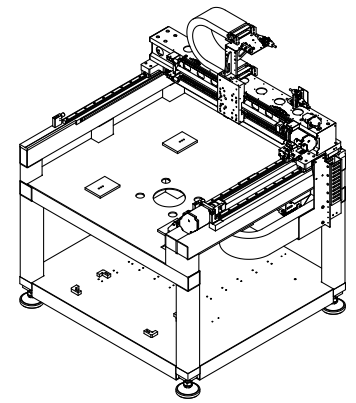

3.27.1 Industry applications

Automation equipment, AOI inspection applications.

3.27.2 Performance specifications

Table3-26 BS-20-540+BS-20-515 product specification

Stage type	BS-20-540+BS-20-515
Motor Type	HIWIN AC Servo motor
Stroke(mm)	X-axis : 515, Y-axis : 540
Ball screw lead(mm)	20
Repeatability(μm)	±2.5(uni-direction, with HIWIN solution)
Accuracy(μm)	±6(after error mapping)
Max. Acceleration(m/s ²)	X-axis : 12, Y-axis : 17(with payload)
Max. Velocity(m/s)	X-axis : 1, Y-axis : 1(with payload)
Vertical Straightness(μm)	20
Horizontal Straightness(μm)	20
Pitch(arc-sec)	30
Yaw(arc-sec)	X-axis : 20, Y-axis : 25
Orthogonality(arc-sec)	±10
Payload(kg)	9
Stage orientation	Horizontal

Note : All specifications can be designed according to customer demand.

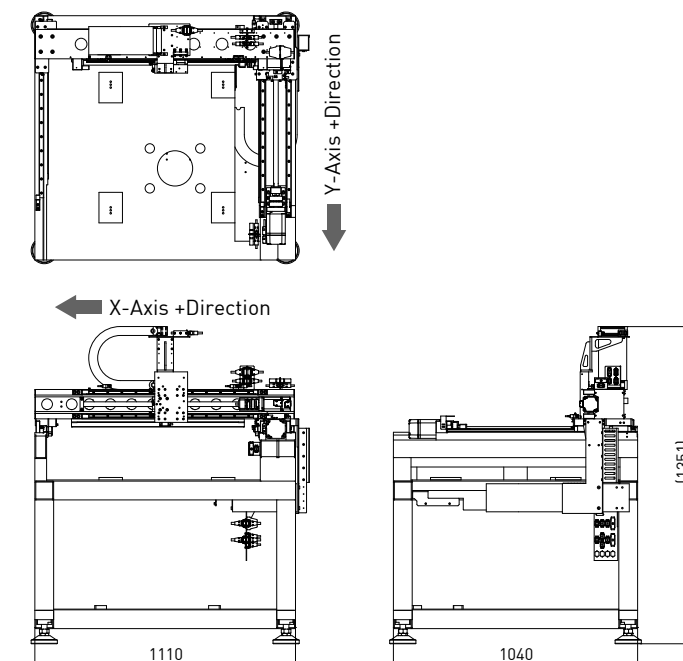

3.28 MLA series

- Integration of high-precision TMN torque motor.
- With excellent flatness(X-Y-theta 0.01 mm).
- Water cooling design, reduce thermal deformation.
- XY Stage low center of gravity design.
- Can be equipped with ironless or ironcore motor.

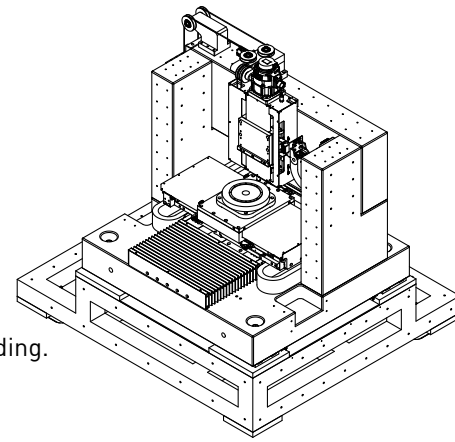

3.28.1 Industry applications

Wafer cutting, the glass substrate testing equipment, wafer bonding.

3.28.2 Performance specifications

Table3-27 LMX2C-F23F43-300-300+BS-5-170+TMN93EH product specification

Stage type	LMX2C-F23F43-300-300+BS-5-170+TMN93EH
Motor Type	Ironcore (/Ironless) motor & HIWIN AC Servo motor
Stroke(mm)	X-axis : 362, Y-axis : 390
Peak Force(N)/Continuous Force(N)	X-axis : 2082/764, Y-axis : 5496/2252
Repeatability(μm)	±0.5(with HIWIN solution)
Accuracy(μm)	±1(after error mapping)
Max. Acceleration(m/s ²)	10(with payload)
Max. Velocity(m/s)	1(with payload)
Payload(kg)	Z-axis : 50, A-axis : 30
Stage orientation	Horizontal
Torque Motor Type	TMN93EH
Peak Torque(Nm)/Continuous Torque(Nm)	45/15
Max. Velocity(rpm)	300(220V)
Repeatability(arc-sec)	±2.5
Accuracy(arc-sec)	±25
Inertia of rotation parts(kgm ²)	0.052

Note : All specifications can be designed according to customer demand.

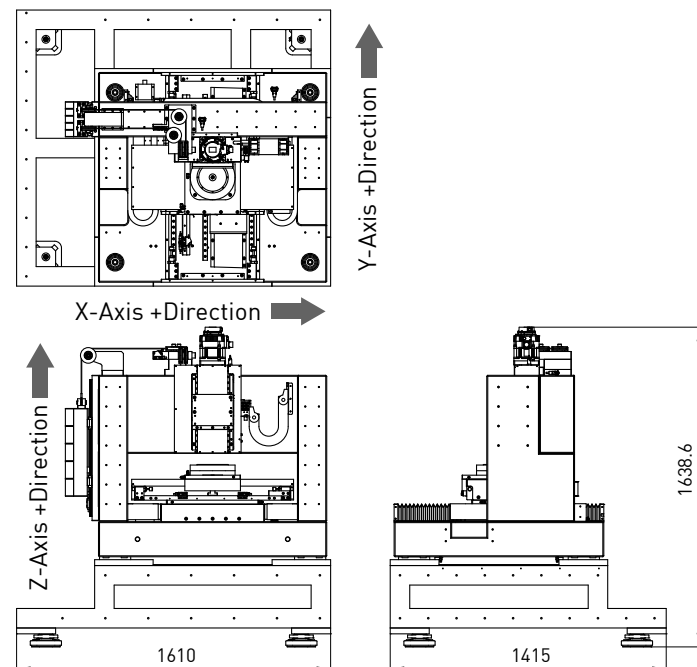

3.29 MLB series

- Multi-axis simultaneously motion.
- Good working efficiency.
- High stiffness honeycomb beam design.
- High acceleration and deceleration motion.
- With excellent settling time.
- Can be used with automated pick and place conveying mechanism.
- Can be equipped with ironless or ironcore motor.

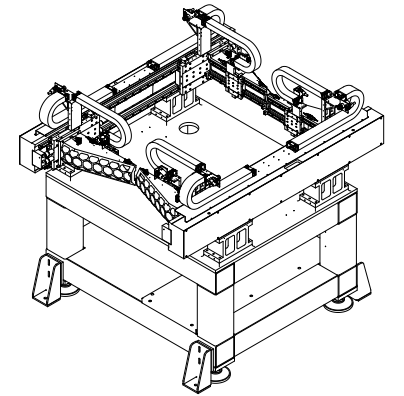

3.29.1 Industry applications

Precision component assembly applications, electronic components plug-in equipment.

3.29.2 Performance specifications

Table3-28 LMX8C-SA11F13-264-632 product specification

Stage type	LMX8C-SA11F13-264-632
Motor Type	Ironcore (/Ironless) motor
Stroke(mm)	X-axis : 264, Y-axis : 632
Peak Force(N)/Continuous Force(N)	X-axis : 289/121, Y-axis : 1380/510
Repeatability(μm)	X-axis : ±1, Y-axis : ±2(with HIWIN solution)
Accuracy(μm)	X-axis : ±3, Y-axis : ±5(after error mapping)
Max. Acceleration(m/s ²)	X-axis : 20, Y-axis : 30(with payload)
Max. Velocity(m/s)	X-axis : 1, Y-axis : 1(with payload)
Horizontal Straightness(μm)	±10
Orthogonality(arc-sec)	±10
Payload(kg)	1
Stage orientation	Horizontal

Note : All specifications can be designed according to customer demand.

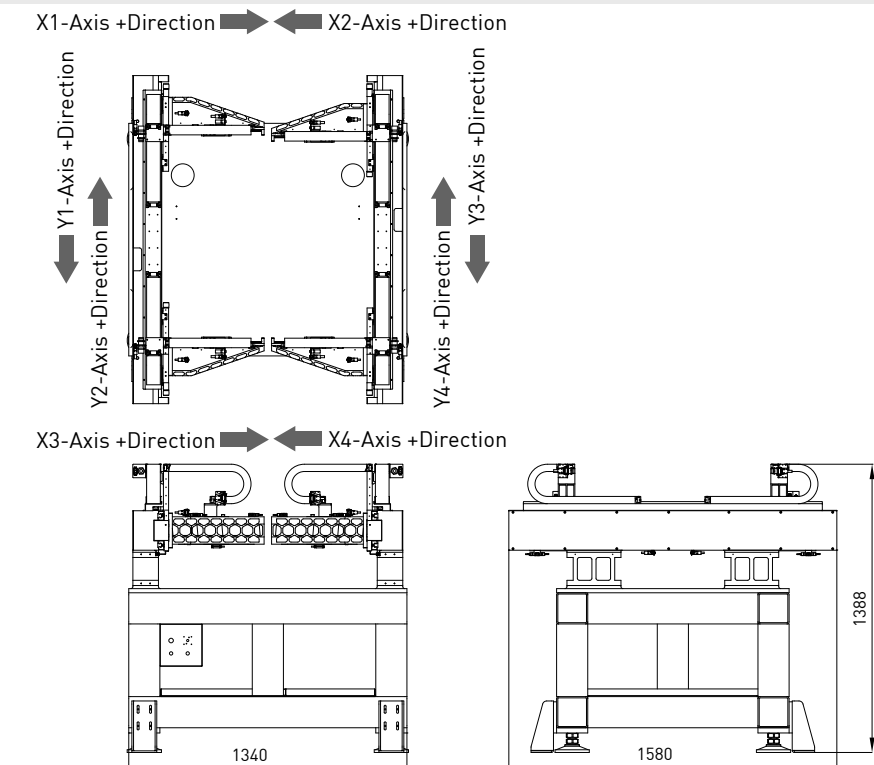

3.30 ALA series

- Using non-contact air bearing.
- Without maintenance.
- High positioning accuracy.
- Not easily influenced by environmental temperature.
- With high-precision and large-size vacuum chuck.
- With passive vibration suppressing system.
- Integrated electronic control system.
- Equipped with ironless motor.

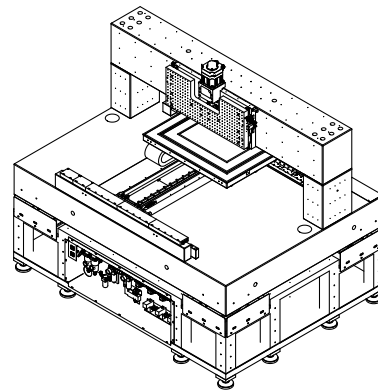

3.30.1 Industry applications

Glass substrate exposure Application, white testing equipment, wafer defect detection equipment.

3.30.2 Performance specifications

Table3-29 LMAP-CC8CB8-700-800+BS-2-50 product specification

Stage type	LMAP-CC8CB8-700-800+BS-2-50
Motor Type	Ironless motor
Stroke(mm)	X-axis : 700, Y-axis : 800, Z-axis : 50
Peak Force(N)/Continuous Force(N)	X-axis : 580/145, Y-axis : 780/195, Z-axis : HIWIN 1KW(220V)
Repeatability(μm)	X-axis : ±0.5, Y-axis : ±0.5, Z-axis : ±2(with HIWIN solution)
Accuracy(μm)	X-axis : ±1.5, Y-axis : ±1.5, Z-axis : ±6(after error mapping)
Max. Acceleration(m/s ²)	X-axis : 2.5, Y-axis : 4(with payload 10 kg), Z-axis : 2(with payload 200 kg)
Max. Velocity(m/s)	X-axis : 0.3, Y-axis : 0.3(with payload 10 kg), Z-axis : 0.05(with payload 200 kg)
Vertical Straightness(μm)	X-axis : ±2, Y-axis : ±2, Z-axis : ±10
Horizontal Straightness(μm)	X-axis : ±1, Y-axis : ±1, Z-axis : ±2
Orthogonality(arc-sec)	XY-axis : ±5
Payload(kg)	XY-axis : 10, Z-axis : 200
Stage orientation	Horizontal

Note : All specifications can be designed according to customer demand.

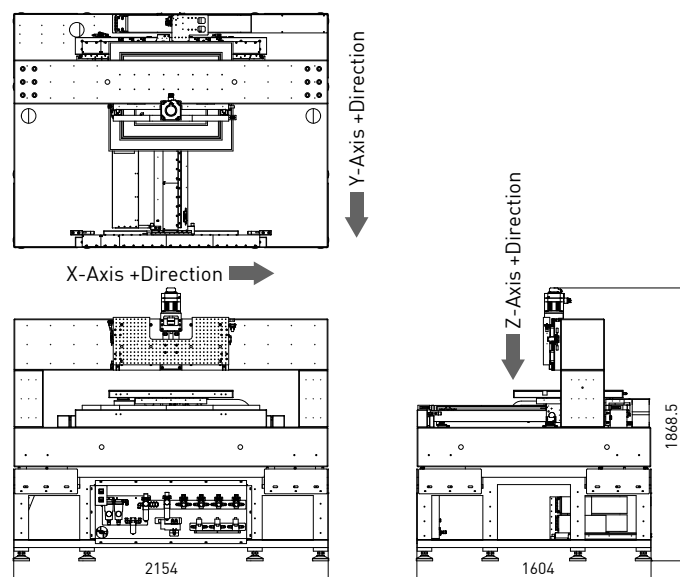

3.31 ALB series

- Using non-contact air bearing.
- Without maintenance.
- High positioning accuracy.
- Not easily influenced by environmental temperature.
- With high-precision and large-size vacuum chuck.
- Z direction jitter 100 nm.
- Vertical straightness up to ±1 μm.
- Equipped with ironless motor.

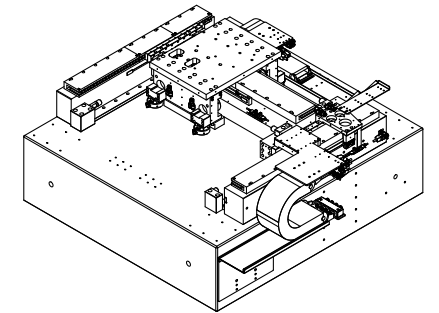

3.31.1 Industry applications

Glass substrate exposure Application, white testing equipment, wafer defect detection equipment.

3.31.2 Performance specifications

Table3-30 LMAP-CC8CB8-250-250 product specification

Stage type	LMAP-CC8CB8-250-250
Motor Type	Ironless motor
Stroke(mm)	X-axis : 250, Y-axis : 250
Peak Force(N)/Continuous Force(N)	X-axis : 780/195, Y-axis : 580/145
Repeatability(μm)	±0.75(with HIWIN solution)
Accuracy(μm)	±1.5(after error mapping)
Max. Acceleration(m/s ²)	2(with payload)
Max. Velocity(m/s)	0.25(with payload)
Vertical Straightness(μm)	±1
Horizontal Straightness(μm)	±2
Orthogonality(arc-sec)	±3
Payload(kg)	15
Stage orientation	Horizontal

Note : All specifications can be designed according to customer demand.

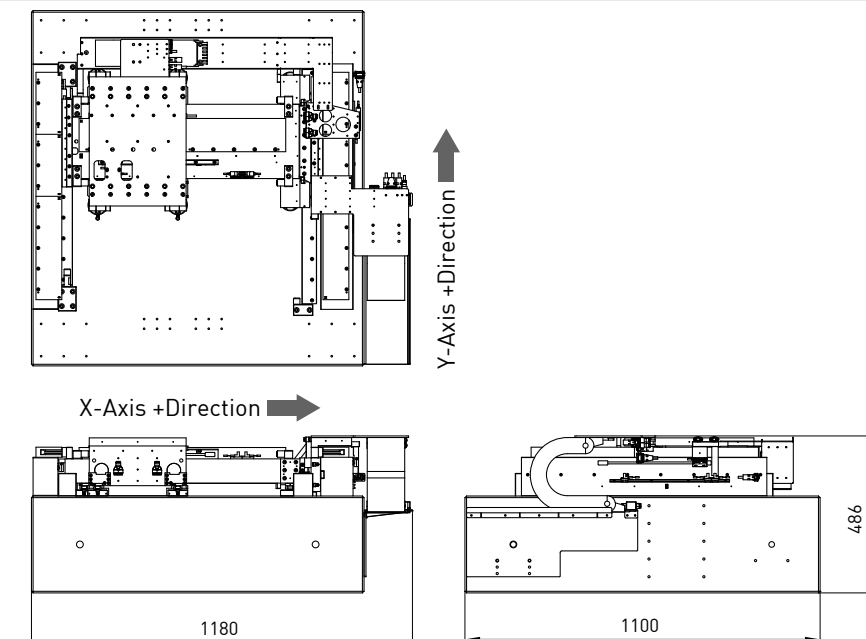

3.32 ALC series

- Using non-contact air bearing.
- Without maintenance.
- High positioning accuracy.
- High load capacity of up to 680 kg.
- Vertical straightness up to $\pm 3 \mu\text{m}$.
- Equipped with ironless motor.

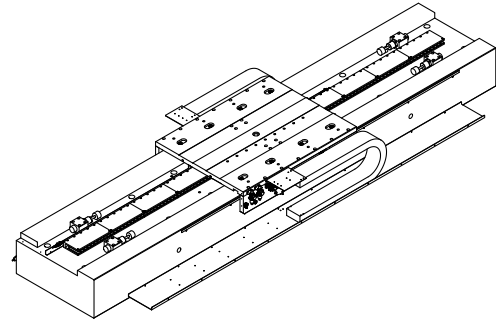

3.32.1 Industry applications

Large-size glass substrate detection equipment

3.32.2 Performance specifications

Table3-31 LMAP-CFC-1-2350 product specification

Stage type	LMAP-CFC-1-2350
Motor Type	Ironless motor
Stroke(mm)	2320
Peak Force(N)/Continuous Force(N)	2736/684
Repeatability(μm)	± 0.5 (with HIWIN solution)
Accuracy(μm)	± 2 (after error mapping)
Max. Acceleration(m/s^2)	2(with payload)
Max. Velocity(m/s)	0.7(with payload)
Vertical Straightness(μm)	± 4
Horizontal Straightness(μm)	± 3
Payload(kg)	680
Stage orientation	Horizontal

Note : All specifications can be designed according to customer demand.

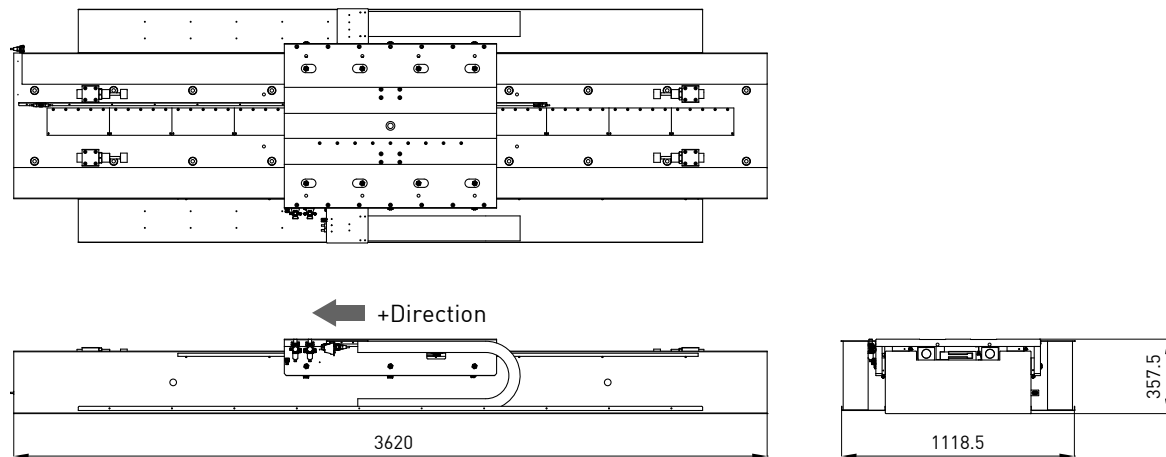

4 Drive

4.1 HIWIN D1 servo motor drive

- Digital drive
- Vector control
- Lightning human, machine interface
- 100-240Vac power input
- Support various pulse wave formats
- Support analog or digital optical scales

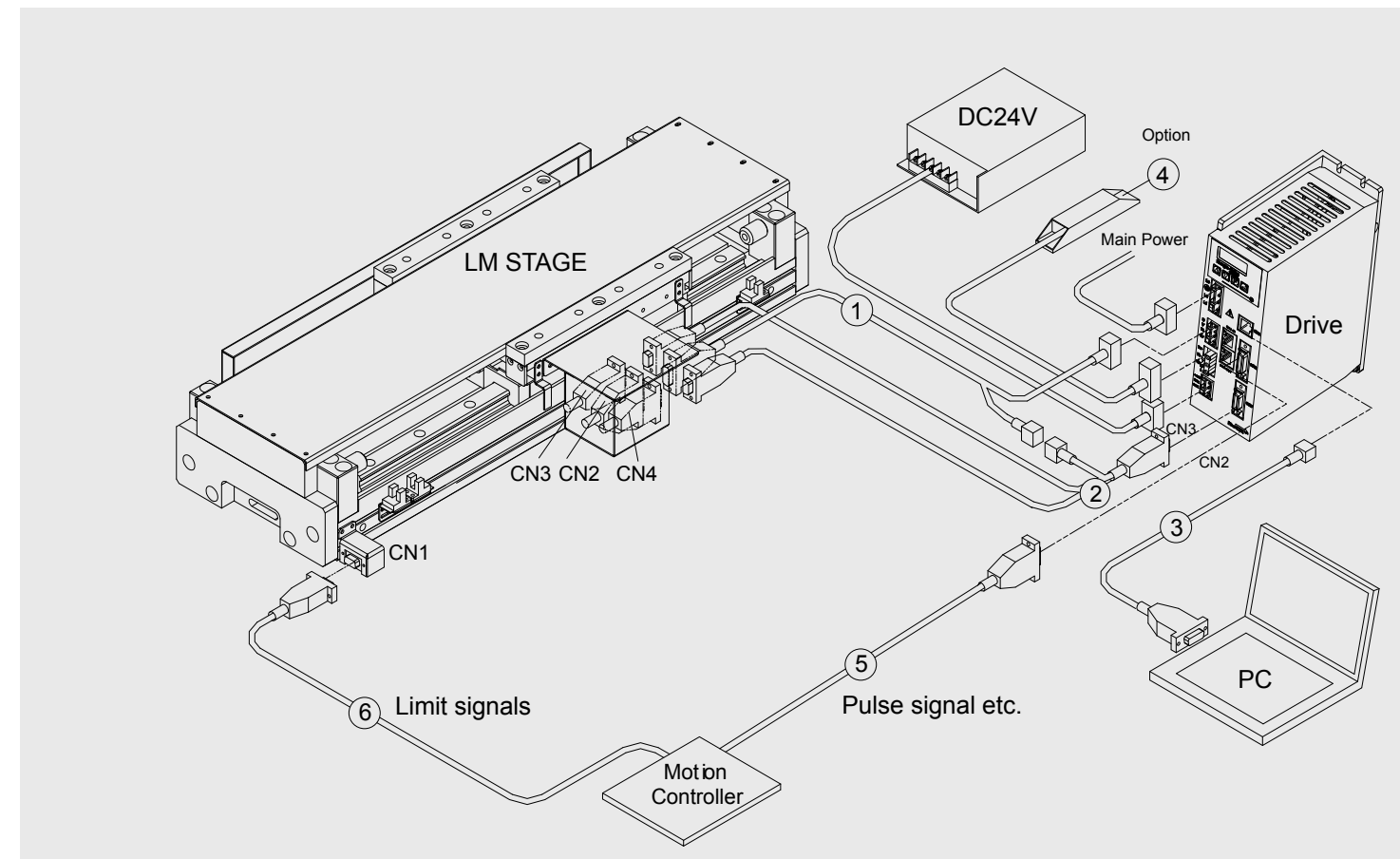

4.2 HIWIN D1-N servo motor drive

- Current vector control
- Best for driving linear motors, shaft motors and torque motors
- 100-240VAC power input
- Supports STP / DIR, CW / CCW, A / B pulse formats (differential / single ended interface)
- Supports ±10V voltage or digital commands for velocity or force/ torque modes
- PDL general motion language
- Supports analog and digital encoder and resolver



4.3 D1 related accessories

Table4-1 Drive peripheral accessories

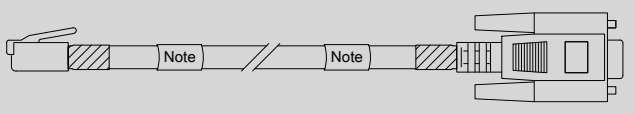
Name	Specification	Connector	Description
③ RS-232communication cable	LMACR21D	D-sub connector and CN1	D-Sub9PIN to RJ-11 
④ ⑩ Regenerative resistor	050100700001		Rated power 100W, instant power 500W
D1 Drive connector accessories kit bag	D1-CK1		All connectors (not included CN3)
			All connectors (also included CN3)
EMC accessories kit bag	D1-EMC1		Single phase power
	D1-EMC2		Three phase power
Heat sink	D1-H1		Standard
	D1-H2		Small type
Digital Hall sensor	LMAHS		Suitable for LMS series, single-ended signal
	LMAHC		Suitable for LMCA,LMCB and LMCC series, single-ended signal
	LMAHC2		Suitable for LMCD and LMCE series, single-ended signal
Analog Hall sensor	LMAHSA-D		Suitable for LMS series, differential signal
	LMAHCA-D		Suitable for LMCA,LMCB and LMCC series, differential signal

Note : Please contact us for hall sensor.

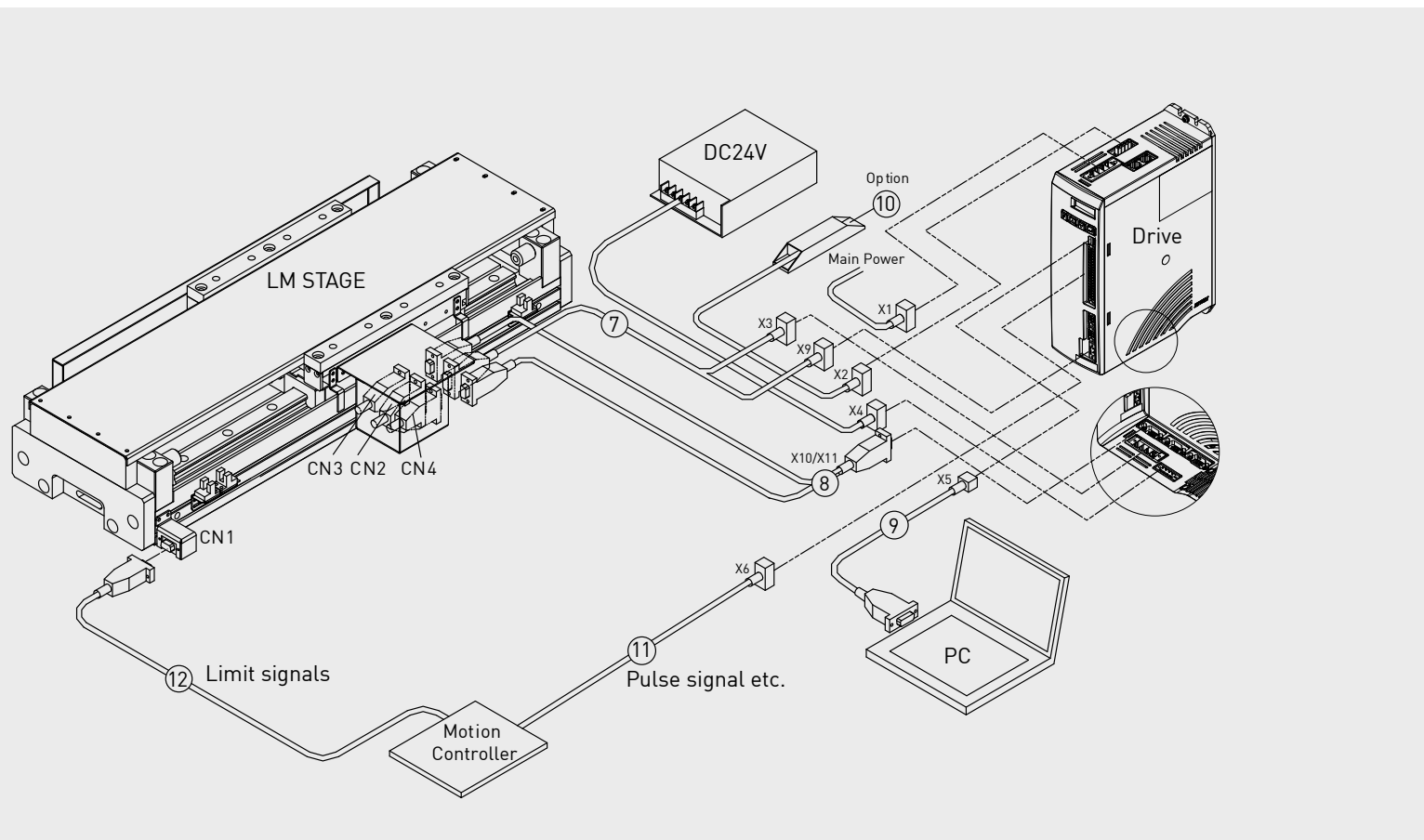

4.4 Cables and connectors

4.4.1 D1 related cables

Table4-2 Control signals, limit signals, motor power cables





Name	Specification	Connector	Description
⑤ Control signal cables	LMACK30R	CN2	To motion controller (about 3 meters long)  Drive connectors (3M) Model: 10126-3000VE
⑥ Limit switch extension cord	LMACK□□S		Suitable for linear motor positioning stages  D-Sub9 Pin to discrete wires
① Motor power supply cables and over-temperature signal cables	LMACS□□D	Motor power connector (U.V.W)	Suitable for LMS series linear motors + LMC series linear motors: LMC-EFE \ LMC-EFF  9W4S to discrete cables and over-temperature connector
	LMACS□□L		Suitable for LMCF motors  9W4S to discrete cables and over-temperature connector
	LMACS□□T		Suitable for LMSA series linear motors  9W4S to discrete cables and over-temperature connector
	LMACS□□K		Suitable for LMC series linear motors: A, B, C, D, E, EFC LMT series linear motors: A, B, C  Interconnect to discrete cables and over-temperature connector
	LMACS□□F		Suitable for TMS \ TMN \ TMY series torque motors (not include over-temperature signal)  Intercontec to discrete cables

Table4-3 Position feedback cables

Drive	Specification	Connector	Description
② HIWIN D1-XX-S2 series	LMACE□□Y	CN3	For Renishaw digital optical scale, motor over-temperature signal. For position feedback D-SUB 15 female connector  Motor over-temperature connector Drive connector (3M) Model no. : 10120-3000VE
	LMACE□□Z		Renishaw digital optical scale, motor over-temperature signal, digital Hall component signals. For position feedback D-SUB 15 female connector  Motor over-temperature connector Digital Hall component D-SUB 9 female connector Drive connector (3M) Model no. : 10120-3000VE
	LMACE□□C		Renishaw digital optical scale, motor over-temperature signal.  Motor over-temperature connector Drive connector (3M) Model no. : 10120-3000VE
	LMACE□□J		Renishaw analog optical scale, motor over-temperature signal, digital Hall component signals.  Motor over-temperature connector Digital Hall component D-SUB 9 female connector Drive connector (3M) Model no. : 10120-3000VE
HIWIN D1-XX-S3 series	LMACE□□AW	CN3	Renishaw digital optical scale, motor over-temperature signal.  Motor over-temperature connector
	LMACE□□AV		Renishaw digital optical scale, motor over-temperature signal, digital Hall component signals.  Motor over-temperature connector
HIWIN D1-XX-S8 series	LMACE□□AA	CN3	Jena for analog encoder, motor over-temperature signal, suitable for TMS series torque motors.  Intercontec Model no. : ASTA876NN0085200A000 Drive connector (3M) Model no. : 10120-3000VE
	LMACE□□AM		Jena for analog encoder, motor over-temperature signal, Hall component signals.  Intercontec Model no. : ASTA876NN0085200A000
HIWIN D1-XX-SR series	LMACE□□AD	Single Resolver extension cable, includes over-temperature signal.  Intercontec Model no. : ASTA876NN0085200A000	
HIWIN D1-XX-DR series	LMACE□□AU	Dual Resolver extension cable, includes over-temperature signal.  Intercontec Model no. : ASTA876NN0085200A000	

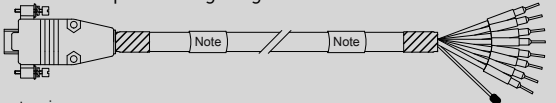
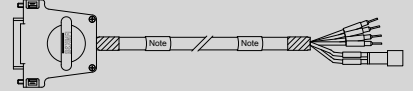
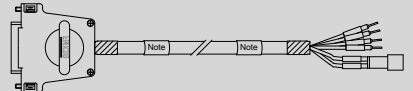
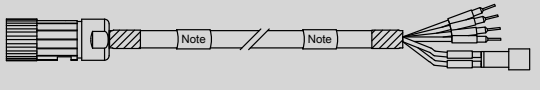
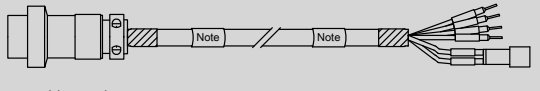
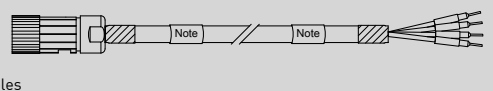
□□	03	04	05	06	07	08	09	10
Cable length (m)	3	4	5	6	7	8	9	10

4.4.2 Pin assignments of D1

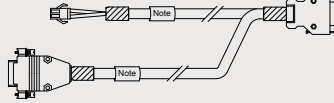
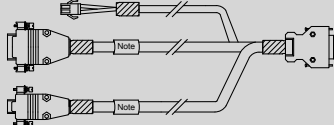
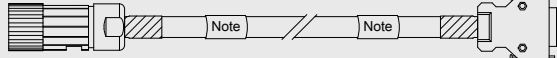
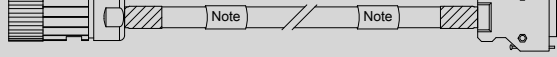
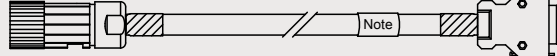
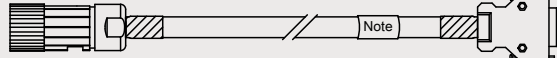
LMACE00Z
LMACE00Y (No Hall component)

Signal	D-SUB 15Pin female connector	Color (051400300063)	D-SUB 20Pin male connector
5V	7	Brown	3
0V	2	White	2
A+	14	Green	4
A-	6	Yellow	5
B+	13	Blue	6
B-	5	Red	7
Z+	12	Violet	8
Z-	4	Grey	9
Inner Shield	15	Inner shield	20
Case	-	Outer shield	1

Signal	2Pin female connector	Color (051400300133)	
T+	1	Brown	14
T-	2	Blue	15

Signal	D-SUB 9Pin female connector	Color (051400100075)	
5V	1	Brown	3
Hall A	2	White	11
Hall B	3	Grey	12
Hall C	4	Yellow	13
0V	5	Green	10
Shield	Case	Shield	1

LMACE00AV
LMACE00AW (No Hall component)

Signal	D-SUB 15Pin female connector	Color (051400300069)	D-SUB 20Pin male connector
5V	7	Brown	3
0V	2	White	2
A+	14	Green	4
A-	6	Yellow	5
B+	13	Blue	6
B-	5	Red	7
Z+	12	Violet	8
Z-	4	Gray	9
Encoder Alarm	3	Pink	18
Inner	15	Inner shield	20
Outer	Case	Outer shield	1

Signal	2Pin female connector	Color (051400100133)	
T+	1	Brown	14
T-	2	Blue	15

Signal	D-SUB 9Pin female connector	Color	
5V	1	Brown	3
Hall A	2	White	11
Hall B	3	Grey	12
Hall C	4	Yellow	13
0V	5	Green	10
Shield	Case	Shield	1

LMACE00AM
LMACE00AA (No Hall component)

Function	8-10-0090 (Female)	JENA Signal	Color (051400300069)	SCSI 20 (Male)	mega-fabs D1 Signal
Power	4	5V	Blue	3	+5Vdc
	5	5V	Blue	-	-
	6	0V	White	2	Signal Gnd
Incremental signals	2	U ₂ -	Red	19	Cos(-)
	3	U ₁ -	Brown	17	Sin(-)
	9	U ₂ +	Black	18	Cos(+)
	10	U ₁ +	Green	16	Sin(+)
Origin signal	1	U ₀ -	Pink	9	/X
	8	U ₀ +	Grey	8	X
Temperature	6	0V	Inner shield	20	Signal Gnd
	Case	Shield	Outer shield	1	Frame Gnd
	11	T+	Violet	14	[IN5] Motemp
	12	T-	Yellow	15	Signal Gnd
Hall sensor	13	Vcc	Blue	3	+5Vdc
	14	HallA	Brown/Green	11	HA
	15	HallB	White/Yellow	12	HB
	16	HallC	White/Green	13	HC
	17	GND	White	10	Signal Gnd

LMACE00J
LMACE00C (No Hall component)

Signal	D-SUB 15Pin female connector	Color (051400300063)	D-SUB 20Pin male connector
5V	4	Brown	3
0V	12	White	2
Sin(+)	9	Green	16
Sin(-)	1	Yellow	17
Cos(+)	10	Blue	18
Cos(-)	2	Red	19
Z+	3	Violet	8
Z-	11	Grey	9
Inner Shield	15	Inner shield	20
Case	-	Outer shield	1

Signal	2Pin female connector	Color (051400100133)	
T+	1	Brown	14
T-	2	Blue	15

Signal	D-SUB 9Pin female connector	Color (051400100075)	
5V	1	Brown	3
Hall A	2	White	11
Hall B	3	Grey	12
Hall C	4	Yellow	13
0V	5	Green	10
Shield	Case	Shield	1

LMACE00AD

Signal	Round connector 17Pin 8-10-0090 Female connector	Color (051400300069)	SCSI 20Pin Male connector
Z+	13	Grey	12
Z-	14	Pink	13
Sin1+	2	Green	16
Sin1-	3	Yellow	17
COS1+	9	Blue	18
COS1-	10	Red	19
VREF+	1	Brown	11
VREF-	8	White	3
Inner	12	Inner shield	15
Outer	Metal housing	Outer shield	1/Case
T+	11	White/Green	14
T-	12	Brown/Green	15
+5V	5	Violet	9
0V	6	Black	10

LMACE00AU

Function	Signal	Round connector 17Pin 8-10-0090 Female connector	Color (051400300069)	SCSI 20Pin Male connector
Resolver1 (20/115)	Vref+	1	Brown	11
		4	White/Yellow	
	Vref-	7	White	3
		8	Yellow/Brown	
Resolver2 (24/114)	SIN+	2	Green	16
	SIN-	3	Yellow	17
	COS+	9	Blue	18
	COS-	10	Red	19
Temperature	SIN+	13	Black	4
	SIN-	14	Violet	5
	COS+	15	Grey	6
Temperature	Inner Shield	16	Pink	7
		12	Inner shield	15
	Outer Shield	Case	Outer shield	1/Case
		T+	11	Brown/Green
T-	12	White/Green	15	

4.5 D1-N related accessories

LMACK30R

Signal	Pin	Color	Wire pair	Color	Pin	Signal
Frame Ground	1	Brown	1a 8a	Blue	14	[Out2]
Signal Ground	2	Brown/White	1b 8b	Blue/White	15	[Out3]
Enable [IN1]	3	Red	2a 9a	Light blue	16	Encoder A In/Out
GP Input [IN2]	4	Red/Black	2b 9b	Light blue /Black	17	Encoder /A In/Out
GP Input [IN3]	5	Orange	3a 10a	Purple	18	Encoder B In/Out
GP Input [IN4]	6	Orange/Black	3b 10b	Purple /White	19	Encoder /B In/Out
HS Input [IN6]	7	Green	6a 11a	Grey	20	Encoder X In/Out
HS Input [IN7]	8	Pink	4a 11b	Grey /Black	21	Encoder /X In/Out
HS Input [IN8]	9	Yellow	5a 12a	White/Red	22	+5 Vdc @ 400mA
HS Input [IN9]	10	Pink/Black	4b 12b	White/Blue	23	Signal Ground
HS Input [IN10]	11	Yellow/Black	5b 13a	White	24	Analog Ref In (+)
GP Input [IN11]	12	Green/Black	6b 13b	White /Black	25	Analog Ref In (-)
[Out1]	13	Light green	7a 7b	Light green/Black	26	[IN12] GP Input
Shield	Case					

NOTE: Wire pair 1a and 1b represent diagonal.

LMACK□□□

Signal	Pin	Color	Wire set
Vcc	1	Yellow	+
GNb	9	Green	-
Negative limit signal output	3	Grey	1-OUT
* Reference notes	2	White	1-L
Positive limit signal output	5	Pink	2-OUT
* Reference notes	4	Brown	2-L
Origin signal output	7	Red	3-OUT
* Reference notes	6	Blue	3-L

NOTE: If connect wire set "L" to "+", can change wire set "OUT" output contact patterns.

Table4-4 Drive peripheral accessories

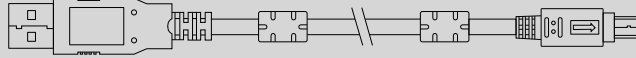
Name	Specification	Connector	Description
⑨ USB 2.0A to Mini-B Cable (5m)			051700800514 
Regenerative resistor	050100700001		Rated power 100W, instant power 500W
D1-N Drive connector accessories kit bag	D1-CK		All connectors
EMC accessories kit bag	D1-N EMC2		Single phase power
	D1-N EMC1		Three phase power

4.5.1 D1-N related cables

Table4-5 Control signals, limit signals, motor power cables

Name	Specification	Connector	Description
⑪ Control signal cables	LMACK□□F	X6	Both ends are scattered lines,suitable for HIWIN D1-N drive series. 
⑦ Motor power supply cables and over-temperature signal cables	LMACS□□U	X3	Suitable for LMC series linear motors: LMC-EFE、LMC-EFF 
	LMACS□□V		Suitable for LMSA motors 
	LMACS□□M		Suitable for LMC series linear motors: A, B, C, D, E, EFC LMT series linear motors: A, B, C, D 
	LMACS□□N		Suitable for LMC series linear motors:F 
	LMACT□□D		Suitable for LMT series linear motors:E 
	LMACS□□Z		Suitable for LMFA series linear motors: LMFA0□□、LMFA1□□、LMFA2□□、LMFA31、LMFA31L、LMFA32、LMFA32L、LMFA41、LMFA41L、LMFA42、LMFA42L、LMFA52、LMFA52L、LMFA62(round metal connector, wire diameter 1.5mm ²) 
	LMACT□□A		Suitable for LMFA series linear motors: LMFA33、LMFA33L、LMFA34、LMFA43、LMFA43L、LMFA44、LMFA53、LMFA53L、LMFA54、LMFA62L、LMFA63、LMFA64,includes KTY and PTC two sets of over-temperature signals.(round metal connector, wire diameter 2.5mm ²) 
	LMACT□□B		Suitable for LMFA series linear motors: LMFA34L、LMFA44L、LMFA54L、LMFA63L,includes KTY and PTC two sets of over-temperature signals.(round metal connector, wire diameter 4.0mm ²) 

Table4-5 Control signals, limit signals, motor power cables

Name	Specification	Connector	Description
Motor power supply cables and over-temperature signal cables	LMACS□□C	X3	Suitable for LMFA series linear motors:LMFA64L,includes KTY and PTC two sets of over-temperature signals.(round metal connector, wire diameter 6.0mm ²) 
	LMACS□□R		Suitable for DD series direct drive motors: TMS、TMN、TMY,(not include over-temperature signal) 

Table 4-6 Position feedback cables

Drive	Specification	Connector	Description
⑧ Suitable for linear motors	LMACF□□C	X10	For Renishaw digital optical scale,connector is the D-type connector,doesn't include Hall sensor signal.
	LMACF□□D		For Renishaw digital optical scale,connector is the D-type connector, include Hall sensor signal.
	LMACF□□A	X11	For Renishaw analog optical scale,connector is the D-type connector,doesn't include Hall sensor signal.
	LMACF□□H		For Renishaw analog optical scale,connector is the D-type connector, include Hall sensor signal.
	LMACF□□L		Jena for analog encoder, motor over-temperature signal, suitable for TMS \ TMN□□E motors.
	LMACF□□G		Jena for analog encoder, motor over-temperature signal, hall sensor signals,suitable for TMN□□EH motors.
⑧ Suitable for direct drive motors	LMACF□□E	X12	Single Resolver encoder,with motor over-temperature signal,suitable for TMN motors.
	LMACF□□J		Dual Resolver encoder,with motor over-temperature signal,suitable for TMY \ TMN□□A motors.

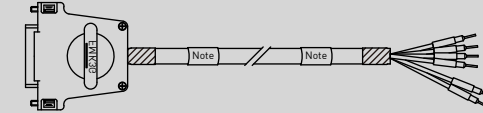
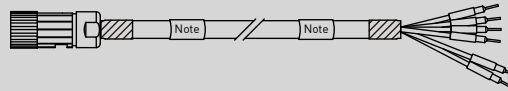
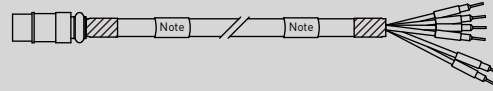
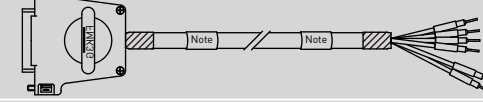
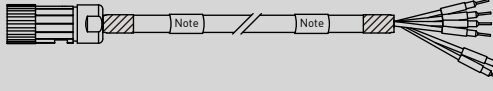
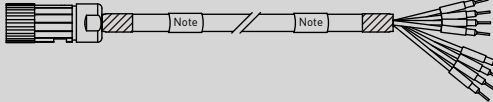
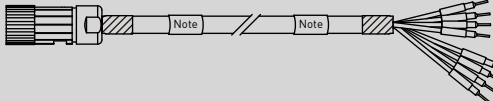
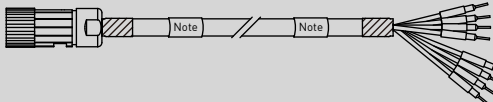
4.5.2 Pin assignments of D1-N

LMACF□□□
LMACF□□□ (No Hall component)

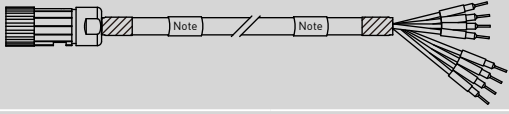
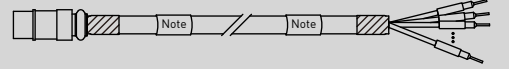
Signal	D-SUB 15Pin female connector	Color (051400300069)	X10HD-SUB 15Pin male connector
5V	7	Brown	5
	8	Brown/Yellow	
0V	2	White	15
	9	White/Yellow	
A+	14	Green	1
A-	6	Yellow	6
B+	13	Blue	2
B-	5	Red	7
Z+	12	Violet	3
Z-	4	Grey	8
Inner Shield	15	Inner shielding	15
Outer	Case	Outer shielding	Case
Signal	9Pin female connector	Color (051400100075)	
5V	1	Brown	5
Hall A	2	White	9
Hall B	3	Grey	10
Hall C	4	Yellow	11
0V	5	Green	15
Shield	Case	Shield	Case

LMACE□□□
LMACE□□□ (No Hall component)

Signal	D-SUB 15Pin female connector	Color (051400300069)	X11HD-SUB 15Pin male connector
5V	4	Brown	5
	5	Brown/Yellow	
0V	12	White	15
	13	White/Yellow	
Sin(+)	9	Green	1
Sin(-)	1	Yellow	6
Cos(+)	10	Blue	2
Cos(-)	2	Red	7
Z+	3	Violet	3
Z-	11	Grey	8
Inner Shield	15	Inner shielding	15
Outer	Case	Outer shielding	Case
Signal	D-SUB 9Pin female connector	Color (051400100075)	
5V	1	Brown	5
Hall A	2	White	9
Hall B	3	Grey	10
Hall C	4	Yellow	11
0V	5	Green	15
Shield	Case	Shield	Case

LMACF□□□
LMACF□□□ (No Hall component)

Function	JENA Signal	17Pin female connector	Color (051400300069)	X12 HD-SUB 15Pin female connector	Color (051400100133)	Line number casing	
Power	5V	4	Blue	5	Brown	T+	
	5V	5	Blue	5		Blue	T-
	0V	6	White	15			
Incremental signals	U ₂ -	2	Red	7	Color (051400300063)	X10 HD-SUB 15Pin male connector	
	U ₁ -	3	Brown	6			
	U ₂ +	9	Black	2			
Origin signal	U ₁ +	10	Green	1	Blue	5	
	U ₀ -	1	Pink	8	Brown	9	
	U ₀ +	8	Grey	3	Yellow	10	
Temperature	Shield	Case	Inner shield	15	Green	11	
	T+	11	Purple		White	15	
	T-	12	Yellow				
Hall sensor	Vcc	13	Blue				
	HallA	14	Brown/Green				
	HallB	15	White/Yellow				
	HallC	16	White/Green				
	GND	17	White				

LMACF00E

Signal	Round connector 17Pin 8-10-0090 Female connector	Color (051400300108)	X12HD- SUB 15Pin female connector	Color (051400300138)	Line number casing
5V	5	Brown Brown/Green	5		
0V	6	White White/Green	4		
Sin1+	2	Green	1		
Sin1-	3	Yellow	6		
COS1+	9	Blue	2		
COS1-	10	Red	7		
VREF+	1	Gray	11		
VREF-	8	Pink	12		
Z+	13	Black	13		
Z-	14	Violet	14		
T+	11	Gray/Pink		Brown	T+
T-	12	Red/Blue		White	T-
Shield	Case	Shield	15		

LMACF00J

Signal	Round connector 17Pin 8-10-0090 Female connector	Color (051400300108)	X12HD- SUB 15Pin female connector	Color (051400300138)	Line number casing
Sin1+	2	Green	1		
Sin1-	3	Yellow	6		
COS1+	9	Brown	2		
COS1-	10	White	7		
Sin2+	13	Blue	3		
Sin2-	14	Red	8		
COS2+	15	Gray	9		
COS2-	16	Pink	10		
VREF+	1/4	Black	11		
VREF-	7/8	Violet	12		
T+	11	Brown/Green		Brown	T+
T-	12	White/Green		White	T-
Shield	Case	Outer shielding	Case		

LMACK00F

Signal	Pin	Color	Signal	Pin	Color
CWL	1	White	FG	21	Light blue
CCWL	2	White/Black	GND	22	Light blue/Black
CW+	3	Red	01+	23	Light green
CW-	4	Red/Black	01-	24	Light green /Black
CCW+	5	Yellow	02+	25	White/Red
CCW-	6	Yellow/Black	02-	26	White/Blue
I1	7	Green	03+	27	Red/White
I2	8	Green/Black	03-	28	Red/Blue
I3	9	Blue	PT+	29	Yellow/Red
I4	10	Blue/White	PT-	30	Yellow/Blue
I5	11	Brown	N/A	31	Green/White
I6	12	Brown/White	N/A	32	Light green /Blue
I7	13	Orange	A	33	Gray/Red
I8	14	Orange/Black	/A	34	Gray/Blue
I9	15	Gray	B	35	Pink/Red
I10	16	Gray/Black	/B	36	Pink/Blue
COM	17	Purple	Z	37	Light blue/Red
REF+	18	Pink	/Z	38	Light blue/Blue
REF-	19	Pink/Black	CZ	39	Light green /Red
DSF+	20	Violet/White	DSF-	40	Green/Blue

Appendix A: Motor Sizing

Start Motor Sizing

The following contents describe how to choose proper motor according to speed, moving distance, and Payloading inertia. The basic process for sizing a motor is:

- Decide motion profile and required parameters
- Calculate peak and continuous force
- Select motor

Symbols

- X : move distance (mm)
- T : move time (sec)
- a : acceleration (mm/s²)
- V : velocity (mm/s)
- M_L: Payloading (kg)
- g : gravitation acceleration (mm/s²)
- F_p: peak force (N)
- F_c: continuous force (N)
- F_a: attraction force between stator and forcer (applicable for LMS, LMF series) (N)
- F_i: inertia force (N)
- K_p: force constant (N/Arms)
- I_p: peak current (Arms)
- I_e: effective current (Arms)
- I_c: continuous current (Arms)
- V₀: starting velocity (mm/s)

STEP 1 Decide motion velocity profile and required parameters

In order to determine the correct motor for a particular application it is necessary to be familiar with the motion equation.

Motion equation

Basic kinematics equations are described as follows:

$$V = V_0 + aT$$

$$X = V_0T + \frac{1}{2}aT^2$$

Where V is velocity, a is acceleration, T is move time and X is move distance. You can choose two of the four parameters (V, a, T and X) as your designed parameters, then the last two parameters can be calculated by above equations.

Motion velocity profile

1. 1/3-1/3-1/3 trapezoid profile
If the distance (X) and move time (T) have been given, the most common and efficient velocity profile for point-to-point motion is the "1/3-1/3-1/3" trapezoid curve because it provides the optimal move by minimizing the power required to complete the move. It breaks the time of the acceleration, Strokeing, and deceleration into three segments as shown below.

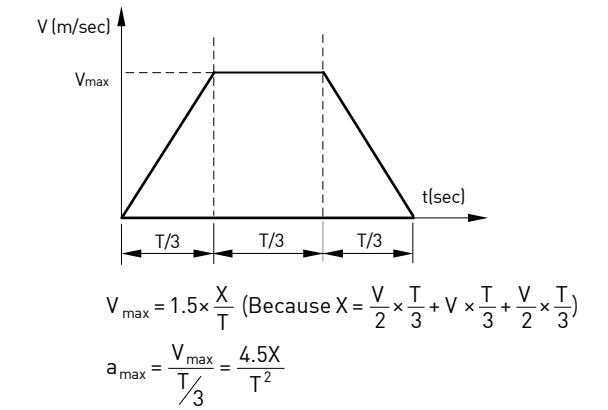

Herein the parameters are described as motion equation.

2. 1/2-1/2 triangle profile

If X and T are given, another common motion profile is the 1/2-1/2 triangle profile. The motion is divided into two parts, namely acceleration and deceleration. The second motion velocity profile is shown as follows.

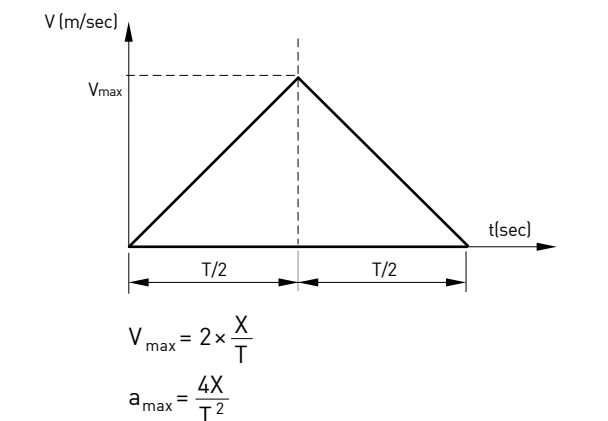

3. Some useful equations

	<p>1/3 -1/3-1/3 Trapezoid profile</p>	<p>Triangle profile</p>
V	$1.5 \times \frac{X}{T}$	$2 \times \frac{X}{T}$, or $\sqrt{a \times X}$
a	$\frac{4.5X}{T^2}$	$\frac{4X}{T^2}$
t	$\frac{X}{V_{max}} + \frac{V_{max}}{a}$ (if $\frac{X}{V_{max}} \geq \frac{V_{max}}{a}$)	

The acceleration required in the first motion velocity profile is bigger than that in the second motion velocity profile; therefore, the required motor size is bigger. When choosing second motion velocity profile, the chosen motor size is smaller, however, we need to verify the DC bus of driver is bigger enough, due to the higher velocity (V_{max}).

STEP 2 Determine peak force and effective force

The peak force can be calculated by the follow equation

$$F_p = M_L \times a_{max} + (M_L \times g + F_a) \times \mu = F_i + F_f$$

Where F_i is inertia force while F_f is friction force, and μ is friction factor.

In most cases, motions are cyclic point-to-point movements. Assuming a cyclic motion shown in the following profile with a pause time of t_4 second, the effective force can be calculated as following formula:

$$F_e = \sqrt{\frac{(F_i + F_f)^2 t_1 + F_f^2 t_2 + (F_i - F_f)^2 t_3}{t_1 + t_2 + t_3 + t_4}}$$

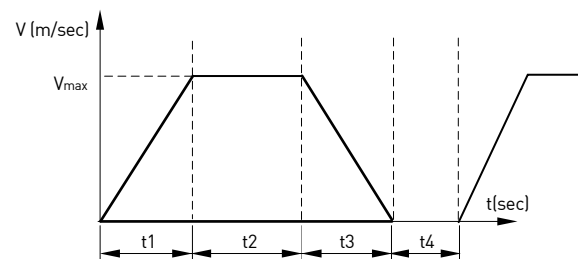

The peak current I_p and effective current I_e can be calculated by using motor force constant K_f .

$$I_p = \frac{F_p}{K_f}$$

$$I_e = \frac{F_e}{K_f}$$

STEP 3 Select motor by peak force and verify the current supply of motor

From the HIWIN catalog, you can check the specifications of motor and choose an applicable motor by peak force, and then you can verify the current supply if it is fitted the specification as follows.

$$I_p = \frac{F_p}{K_f} < I_p \text{ (from specification of chosen motor)}$$

$$I_e = \frac{F_e}{K_f} < I_c \text{ (from specification of chosen motor)}$$

Regarding effective and continuous current, the ratio of I_e/I_c had better be less than 0.7 to attain some margin.

Linear Motor Sizing Example

For example, if Payload is 5 kg (moving mass of mechanism is 1 kg and payPayload is 4 kg), friction factor μ is 0.01, distance is 500 mm, move time is 400 ms and dwell time is 350 ms.

At first, we can calculate the V_{max} , a_{max} , F_p and F_e by the formulas described above (choose the first motion velocity profile and LMC series)

$$V_{max} = 1.5 \times \frac{X}{T} = 1.5 \times \frac{0.5}{0.4} = 1.875 \text{ (m/sec)}$$

$$a_{max} = \frac{4.5 \times X}{T^2} = \frac{4.5 \times 0.5}{(0.4)^2} = 14.06 \text{ (m/sec}^2\text{)}$$

$$F_p = M_L \times a_{max} + (M_L \times g + F_a) \times \mu = 5 \times 14.06 + 5 \times 9.81 \times 0.01 = 70.3 + 0.49 = 70.79 \text{ (N)}$$

$$F_e = \sqrt{\frac{[(70.3 + 0.49)^2 + 0.49^2 + (70.3 - 0.49)^2] \times 0.1333}{0.4 + 0.35}} = 41.92 \text{ (N)}$$

In this case, we can choose motor of type LMCA6 (p.48) which can provide up to 187(N) of peak force and continuous force 62(N), and the force constant is 33.8 N/A(rms). Then the current supply of motor can be determined as follows

$$I_p = \frac{F_p}{K_f} = \frac{70.79}{33.8} = 2.09 \text{ (Arms)} < 5.4 \text{ (Arms)}$$

$$I_e = \frac{F_e}{K_f} = \frac{41.92}{33.8} = 1.24 \text{ (Arms)} < 1.8 \text{ (Arms)}$$

$$\frac{I_e}{I_c} = \frac{1.24}{1.8} \times 100\% = 68.89\% < 70\%$$

Appendix B: Sizing a Regen Resistor

1. Gather required information

To calculate the power and resistance of the regen resistor requires information about the amplifier and the motor.

For all applications, gather the following information:

- Detail of motion profile, including acceleration and velocity
- Amplifier model number
- Applied line voltage to amplifier
- Torque/force constant of the motor
- Resistance (line-to-line) of the motor windings

For rotary motor applications, gather additional information

- Payload inertia seen by the motor
- Inertia of the motor

For linear motor applications, gather additional information

- Moving mass

2. Observe the properties of each deceleration during a complete cycle of operation

For each deceleration during the motion cycle, determine:

- Speed at the start of the deceleration
- Speed at the end of the deceleration
- Time over which the deceleration takes place

3. Calculate energy returned for each deceleration

The energy returned during each deceleration can be calculated by the following formulas.

Rotary motor:

$$E_{dec} = \frac{1}{2} J_t (\omega_1^2 - \omega_2^2)$$

E_{dec} (joules): Energy returned by the deceleration

J_t (kg m^2): Payload inertia on the motor shaft plus the motor inertia

(radians /sec): Shaft speed at the start of deceleration

(radians /sec): Shaft speed at the end of deceleration

I_e : effective current (Arms)

Linear motor:

$$E_{dec} = \frac{1}{2} M_t (V_1^2 - V_2^2)$$

E_{dec} (joules): Energy returned by the deceleration

M_t (kg): Moving mass

V_1 (meters /sec): Velocity at the start of deceleration

V_2 (meters /sec): Velocity at the end of deceleration

4. Determine the amount of energy dissipated by the motor

Calculate the amount of energy dissipated by the motor due to current flow through the motor winding resistance using the following formula.

$$P_{motor} = \frac{3}{4} R_{winding} \left(\frac{F}{K_t} \right)^2$$

P_{power} (watts): Power dissipated in the motor

$R_{winding}$ (ohm): Line to Line resistance of the motor coil

F : Force need to decelerate the motor

Nm for rotary applications

N for linear applications

K_t : Torque constant for the motor

Nm/Amp for rotary applications

N/Amp for linear applications

$E_{motor} = P_{motor} T_{decel}$

E_{motor} (joules): Energy dissipated in the motor

T_{decel} (seconds): Time of deceleration

5. Determine the amount of energy returned to the amplifier

Calculate the amount of energy that will be returned to the amplifier for each deceleration using the following formula

$E_{returned} = E_{dec} - E_{motor}$

$E_{returned}$ (joules): Energy returned to the amplifier

E_{dec} (joules): Energy returned by the deceleration

E_{motor} (joules): Energy dissipated by the motor

6. Determine if energy returned exceeds amplifier capacity

Compare the amount of energy returned to the amplifier in each deceleration with the amplifier's absorption capacity. The following formula is used to determine the energy that can be absorbed by the amplifier.

$$W_{capacity} = \frac{1}{2} C (V_{regen}^2 - (1.414 V_{mains})^2)$$

$W_{capacity}$ (joules): The energy that can be absorbed by the bus capacitor

C (farads): Bus capacitance

V_{regen} (volts): Voltage at which the regen circuit turns on

V_{mains} (volts): Mains voltage (AC) applied to the amplifier

7. Calculated energy to be dissipated for each deceleration

For each deceleration where the energy exceeds the amplifier's capacity, using the following formula to calculate the energy that must be dissipated by the regen resistor.

$E_{regen} = E_{returned} - E_{amp}$

E_{regen} (joules): Energy that must be dissipated in the regen resistor

$E_{returned}$ (joules): Energy delivered back to the amplifier from the motor

E_{amp} (joules): Energy that the amplifier will absorb

8. Calculate pulse power of each deceleration that exceeds amplifier capacity

For each deceleration where energy must be dissipated by the regen resistor, use the following formula to calculate the pulse power that will be dissipated by the regen resistor

$P_{pulse} = E_{regen} / T_{decel}$

P_{pulse} (watts): Pulse power

E_{regen} (joules): Energy that must be dissipated in the regen resistor

T_{decel} (seconds): Time of deceleration

9. Calculate resistance needed to dissipate the pulse power

Using the maximum pulse power from the previous calculation, calculate the resistance value of the regen resistor required to dissipate the maximum pulse power.

$R = V_{regen}^2 / P_{pulse\ max}$

R (ohms): Resistance

$P_{pulse\ max}$: The maximum pulse power

V_{regen} : The voltage at which the regen circuit turns on

Choose a standard value of resistance less than the calculated value. The value must also be greater than the minimum regen resistor value specified by the amplifier supplier.

10. Regen resistor sizing example

Gather required information

LM ROBOTS type: LMXL1L-S37L-1200-G200

Amplifier: mega-fabs D1

DC bus capacitance: 1880uF

Regen circuit turn on voltage: 390V

Minimum resistance: 15 Ω

Moving mass: 86Kg (include payload 74 Kg)

V_{max} : 2 m/s

Acceleration, deceleration: 5 m/s²

Power supply (AC) of driver: 220VAC

Motor type: LMS37L

Force constant (Kf): 68N/A(rms)

$R_{winding}$: 2 ohms(line-to-line)

Calculate regen resistor as following step:

$$F = ma = 86 \times 5 = 430 \text{ (N)}$$

$$E_{dec} = \frac{1}{2} m_t V^2 = \frac{1}{2} \times 86 \times 2^2 = 172 \text{ (joule)}$$

$$P_{motor} = \frac{3}{4} \times R_{winding} \times \left(\frac{F}{K_f} \times \sqrt{2} \right)^2 = \frac{3}{4} \times 2 \times \left(\frac{430}{68} \times \sqrt{2} \right)^2 = 120 \text{ (Watt)}$$

$$E_{motor} = P_{motor} \times T_{decel} = 120 \times \left(\frac{2}{5} \right) = 48 \text{ (joule)}$$

$$E_{returned} = E_{dec} - E_{motor} = 172 - 48 = 124 \text{ (joule)}$$

$$W_{capacity} = \frac{1}{2} \times C \times (V_{regen}^2 - (1.414 V_{mains})^2) = \frac{1}{2} \times 1880 \times 10^{-6} \times (390^2 - (1.414 \times 220)^2) = 51.98 \text{ (joule)}$$

$\therefore E_{returned} > W_{capacity}$

$$E_{regen} = E_{returned} - E_{amp} = 124 - 51.98 = 72.02 \text{ (joule)}$$



$$P_{pulse} = E_{regen} / T_{decel} = 72.02 / 0.4 = 180.05 \text{ (Watt)}$$

Because the total value of selected resistance must be less than 844.77 ohms and the power capacity must be more than 180.05 watts, we choose two resistors and connect them in series, in each resistor the resistance is 68 ohms and power capacity is 100W. The total resistance value is 136 ohms and power capacity is 200W. The resistance order number is 050100700001.

Appendix C: Inquiry form, Mechanical System

Fields marked with asterisk (*) are required.

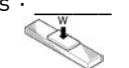
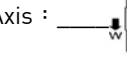
Date: _____

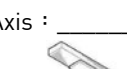
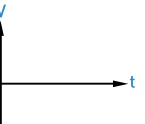
Customer name : _____		Contact HIWIN : _____	
Email : _____		Inquiry No. : _____	
Tel. : _____ Fax. : _____		Business owners : _____	
*Industry/Application	_____	Multi-forcers	<input type="checkbox"/> Yes, quantity : _____ pcs <input type="checkbox"/> No
*Operational environment	<input type="checkbox"/> Indoor, general 25°C <input type="checkbox"/> Cleaning room, class : _____ <input type="checkbox"/> Vacuum, _____ <input type="checkbox"/> Others _____	Required measurement protocol	<input type="checkbox"/> Straightness(H) _____ μm <input type="checkbox"/> Straightness(V) _____ μm <input type="checkbox"/> Pitch _____ arc-sec <input type="checkbox"/> Yaw _____ arc-sec
*Stage type	<input type="checkbox"/> Single <input type="checkbox"/> Dual axis Bridge <input type="checkbox"/> Gantry (single-driven) <input type="checkbox"/> Gantry (dual-driven) <input type="checkbox"/> Others _____	*Cover	<input type="checkbox"/> No <input type="checkbox"/> Metal cover <input type="checkbox"/> Bellows
*Payload	<input type="checkbox"/> Mass : _____ kg <input type="checkbox"/> Dimensions : _____ mm <input type="checkbox"/> Offset, X : _____ mm, Y : _____ mm, Z : _____ mm	Cable chain	<input type="checkbox"/> No <input type="checkbox"/> Horizontal <input type="checkbox"/> Vertical
		*Movement	<input type="checkbox"/> Point to point movement <input type="checkbox"/> Scanning
External force (N)	X-axis _____ Y-axis _____ Z-axis _____	Drive	Firmware version <input type="checkbox"/> Latest version <input type="checkbox"/> Specific version : _____
*Max. speed(m/s)	X-axis _____ Y-axis _____ Z-axis _____		Voltage <input type="checkbox"/> 110V <input type="checkbox"/> 220V <input type="checkbox"/> Other, _____ V
*Max. acceleration(m/s²)	X-axis _____ Y-axis _____ Z-axis _____		formet <input type="checkbox"/> Pulse <input type="checkbox"/> STEP/DIR <input type="checkbox"/> CW/CCW <input type="checkbox"/> A/B
*Stroke(mm)	X-axis _____ Y-axis _____ Z-axis _____	command	<input type="checkbox"/> Analog voltage command <input type="checkbox"/> Bus <input type="checkbox"/> mega-ulink <input type="checkbox"/> EtherCAT <input type="checkbox"/> Modbus
Repeatability(μm)	<input type="checkbox"/> Uni-dir. : _____ <input type="checkbox"/> Bi-dir. : _____	Wiring board included	<input type="checkbox"/> Yes (Please fill out appendix D) <input type="checkbox"/> No
Accuracy(μm)	_____	Software requirements	<input type="checkbox"/> Yes (Please fill in the remarks column) <input type="checkbox"/> No
Encoder type(μm)	<input type="checkbox"/> Analog <input type="checkbox"/> Digital <input type="checkbox"/> Absolute : _____ Resolution : _____	Upper controller	<input type="checkbox"/> Specify <input type="checkbox"/> Motion board <input type="checkbox"/> Controller <input type="checkbox"/> IPC <input type="checkbox"/> PLC <input type="checkbox"/> Customer provide
			Position trigger function
*Stage installation	<input type="checkbox"/> Horizon Axis :  <input type="checkbox"/> Vertical Axis :  <input type="checkbox"/> Hang Axis :  <input type="checkbox"/> Upside-down Axis : 	Distance _____ mm	
Others	_____	Travel time _____ sec	
		Dwelling time _____ sec	
		Motion profile	
The information below is to be filled out by HIWIN or authorized agents. Recommended specification:			

Appendix D: Inquiry form, Electric Control System

Fields marked with asterisk (*) are required.

Date: _____

*Power system	Input Voltage	<input type="checkbox"/> 110V <input type="checkbox"/> 220V(Single phase) <input type="checkbox"/> 220V(Three-phase) <input type="checkbox"/> Other: _____ V <input type="checkbox"/> HIWIN design	Optional parts	<input type="checkbox"/> Socket	Input Voltage: _____ V Quantity: _____
	Connector type	<input type="checkbox"/> H Type(Input current < 15A.) <input type="checkbox"/> T Type(Input current < 15A.) <input type="checkbox"/> Bare Wire <input type="checkbox"/> Other: _____		<input type="checkbox"/> I/O terminal	Input quantity _____: <input type="checkbox"/> NPN <input type="checkbox"/> PNP <input type="checkbox"/> Dry contact Output quantity _____: <input type="checkbox"/> NPN <input type="checkbox"/> PNP <input type="checkbox"/> Dry Contact Output current : _____ mA
	UPS	<input type="checkbox"/> Yes ___ KVA <input type="checkbox"/> No		<input type="checkbox"/> No	
*Control panel	<input type="checkbox"/> Wiring Panel	Installation method <input type="checkbox"/> Vertical <input type="checkbox"/> Horizontal <input type="checkbox"/> Drawer-Type Dimension(Unit: inch): L: _____ W: _____ H: _____	HIWIN document	<input type="checkbox"/> Spare parts list(.pdf) <input type="checkbox"/> N/A	
	<input type="checkbox"/> Electric Cabinet	Material type and Surface processing: <input type="checkbox"/> Stainless Steel <input type="checkbox"/> Aluminum <input type="checkbox"/> Coated <input type="checkbox"/> Non-Coated Dimension(Unit: inch): <input type="checkbox"/> 8U: L: 26" W: 19" H: 14" <input type="checkbox"/> 8U: L: 48" W: 19" H: 14" <input type="checkbox"/> Other: _____	Screen	<input type="checkbox"/> Touchscreen Quantity: _____ Size: _____ inches <input type="checkbox"/> Non-touchscreen Quantity: _____ Size: _____ inches <input type="checkbox"/> No	
			Industrial specification	<input type="checkbox"/> Required safety approval: _____ Customer wiring method: <input type="checkbox"/> Customer wiring method <input type="checkbox"/> HIWIN Standard	
	<input type="checkbox"/> HIWIN Design		Designated parts	<input type="checkbox"/> List of designated parts(.PDF)(.xls) <input type="checkbox"/> List of designated parts (Customer-supplied)(.PDF)(.xls)	
*Emergency stop mode	<input type="checkbox"/> Keep Motor power-off (Control power retains.) <input type="checkbox"/> Keep Drive disable (Control power retains.) <input type="checkbox"/> HIWIN design		Alarm	<input type="checkbox"/> Stack light <input type="checkbox"/> Buzzer <input type="checkbox"/> Safety Light Curtains <input type="checkbox"/> Other: _____ <input type="checkbox"/> N/A (Multiple choice are acceptable.)	
Special requirements:					

MEMO

A series of 25 horizontal dotted lines for writing.

MEMO

A series of 25 horizontal dotted lines for writing.

Linear Motor System Technical Information

Publication Date : May 2002, first edition

Print Date : January 2017, 7th edition

1. HIWIN is the registered trademark of HIWIN Group. For your protection, avoid buying counterfeit products from unknown sources.
 2. Actual products may differ from specifications and photos provided in this catalog. These differences may be the result of various factors including product improvements.
 3. HIWIN will not sell or export products or processes restricted under the "Foreign Trade Act" or related regulations. Export of restricted products should be approved by proper authorities in accordance with relevant laws and shall not be used to manufacture or develop nuclear, biochemical, missiles or other weapons.
-



Global Sales And Customer Service Site

HIWIN GmbH

OFFENBURG, GERMANY
www.hiwin.de
www.hiwin.eu
info@hiwin.de

HIWIN Schweiz GmbH

JONA, SWITZERLAND
www.hiwin.ch
info@hiwin.ch

HIWIN KOREA

SUWON · CHANGWON, KOREA
www.hiwin.kr
info@hiwin.kr

HIWIN JAPAN

KOBE · TOKYO · NAGOYA · NAGANO ·
TOHOKU · SHIZUOKA · HOKURIKU ·
HIROSHIMA · FUKUOKA · KUMAMOTO,
JAPAN
www.hiwin.co.jp
info@hiwin.co.jp

HIWIN s.r.o.

BRNO, CZECH REPUBLIC
www.hiwin.cz
info@hiwin.cz

HIWIN CHINA

SUZHOU, CHINA
www.hiwin.cn
info@hiwin.cn

HIWIN USA

CHICAGO, U.S.A.
www.hiwin.com
info@hiwin.com

HIWIN FRANCE

STRASBOURG, FRANCE
www.hiwin.fr
info@hiwin.de

Mega-Fabs Motion Systems, Ltd.

HAIFA, ISRAEL
www.mega-fabs.com
info@mega-fabs.com

HIWIN Srl

BRUGHERIO, ITALY
www.hiwin.it
info@hiwin.it

HIWIN SINGAPORE

SINGAPORE
www.hiwin.sg
info@hiwin.sg

HIWIN MIKROSYSTEM CORP.

No.6, Jingke Central Rd.,
Taichung Precision Machinery Park,
Taichung 408226, Taiwan
Tel: +886-4-23550110
Fax: +886-4-23550123
www.hiwinmikro.tw
business@hiwinmikro.tw