

HIWIN®



Linear Motors

& Distance Measuring Systems

Motors, Drives & Accessories

Linear Motors & Distance Measuring Systems

Alongside complete linear motor axes and linear motor axis systems, HIWIN also offers individual linear motor components for customised axis design. The linear motors consist of the primary part (forcer) with motor windings, and magnet tracks (stators) with permanent magnets. By combining several stators, travel distances of any length can be created. Similarly, several forcers can be operated on one linear motor axis. These can either be independently controlled on the axis, or be connected in parallel to increase feed power.



Assembly instructions and catalogue for download

Here you can download the corresponding assembly instruction and the current catalogue as PDF files.

Linear Motors & Distance Measuring Systems

Contents

Contents

1	Product overview.....	6
2	HIWIN LMSA linear motors.....	8
2.1	Special characteristics of the LMSA linear motors	8
2.2	Force chart for LMSA linear motors	8
2.3	Order code LMSA linear motors	9
2.4	LMSA linear motor specifications	10
3	HIWIN LMC linear motors.....	20
3.1	Special characteristics of the LMC linear motors	20
3.2	Force chart for LMC linear motors	20
3.3	Order code LMC linear motors	21
3.4	LMC linear motor specifications	22
4	HIWIN LMFA linear motors.....	33
4.1	Special characteristics of the LMFA linear motors	33
4.2	Order code LMFA linear motors	33
4.3	Force chart for LMFA linear motors	34
4.4	LMFA linear motor specifications	36
5	HIWIN LMFP linear motors.....	52
5.1	Special characteristics of the LMFP linear motors	52
5.2	Order code LMFP linear motors	52
5.3	Force chart for LMFP linear motors	53
5.4	LMFP linear motor specifications	54
6	Accessories.....	66
6.1	Stator covers for LMFA/LMFP linear motors	66
6.2	LMFC precision cooler for LMFA/LMFP linear motors	68
6.3	Hall sensors	78
6.4	Motor extension cables	79
6.5	Motor connectors	80
7	HIWIN MAGIC – magnetic distance measuring systems.....	82
7.1	HIWIN distance measuring systems	82
7.2	HIWIN MAGIC-PG distance measuring system	83
7.3	HIWIN MAGIC distance measuring systems: technical data	84
7.4	Connection analogue and digital variant	88
7.5	PMED display	89
7.6	Reference switch	91

Linear Motors & Distance Measuring Systems

Product overview

1. Product overview



HIWIN LMSA linear motors – “The compact power pack”

Page 8

- Optimised for highest power density
- Extremely compact and flat design
- High acceleration



HIWIN LMC linear motors – “The dynamic sprinter”

Page 20

- Ironless lightweight
- Extremely dynamic
- No cogging, thus highest synchronous operation



HIWIN LMFA linear motors – “The cooled heavy-duty drive”

Page 33

- Integrated cooling system
- Extremely high thrust up to 20,000 N
- High acceleration
- UL-certified

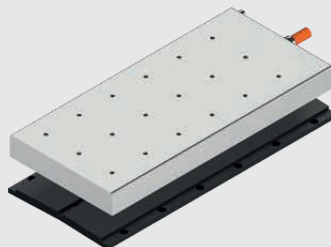

HIWIN LMFP linear motors – “The sealed heavy-duty drive”

Page 52

- Protection class IP65 thanks to encapsulated design
- Integrated cooling system
- Extremely high thrust up to over 20,000 N
- High acceleration

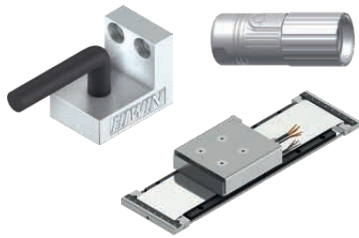

Accessories

Page 66

- Stator covers for LMFA/LMFP linear motors
- Precision cooling for LMFA/LMFP linear motors
- Hall sensors
- Motor cables
- Motor connectors

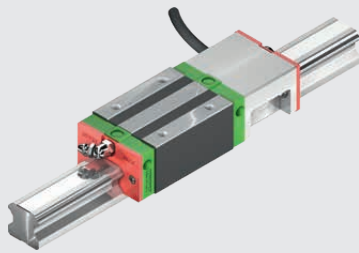

HIWIN MAGIC – magnetic distance measuring systems

Page 82

- Zero contact measuring with 1 V_{PP} or digital output
- Digital resolution of up to 0.5 μm
- Encoder with metal housing and IP67 protection mode
- Signal output in real time

Linear Motors & Distance Measuring Systems

HIWIN LMSA linear motors

2. HIWIN LMSA linear motors

2.1 Special characteristics of the LMSA linear motors

The HIWIN LMSA synchronous linear motors are the compact power packs of linear actuators. The linear motors in the LMSA series stand out for their extremely high power density and very flat design. Due to their low motor mass, the actuators can be operated in a highly dynamic manner. A high synchronous operation is achieved through the optimised configuration of the permanent magnets in the stator. The benefits of the LMSA linear motors make them the preferred choice in fields with limited installation space and high feed thrust requirements.



Key features of the LMSA linear motors:

- Highest power density
- Flat design
- High acceleration
- High synchronous run
- Full epoxy encapsulation of permanent magnets in the stator
- Optional: version with Hall sensor

Typical fields of application of the LMSA linear motors:

- Automation technology
- Handling
- Packaging
- Semiconductors
- Measuring technology

2.2 Force chart for LMSA linear motors

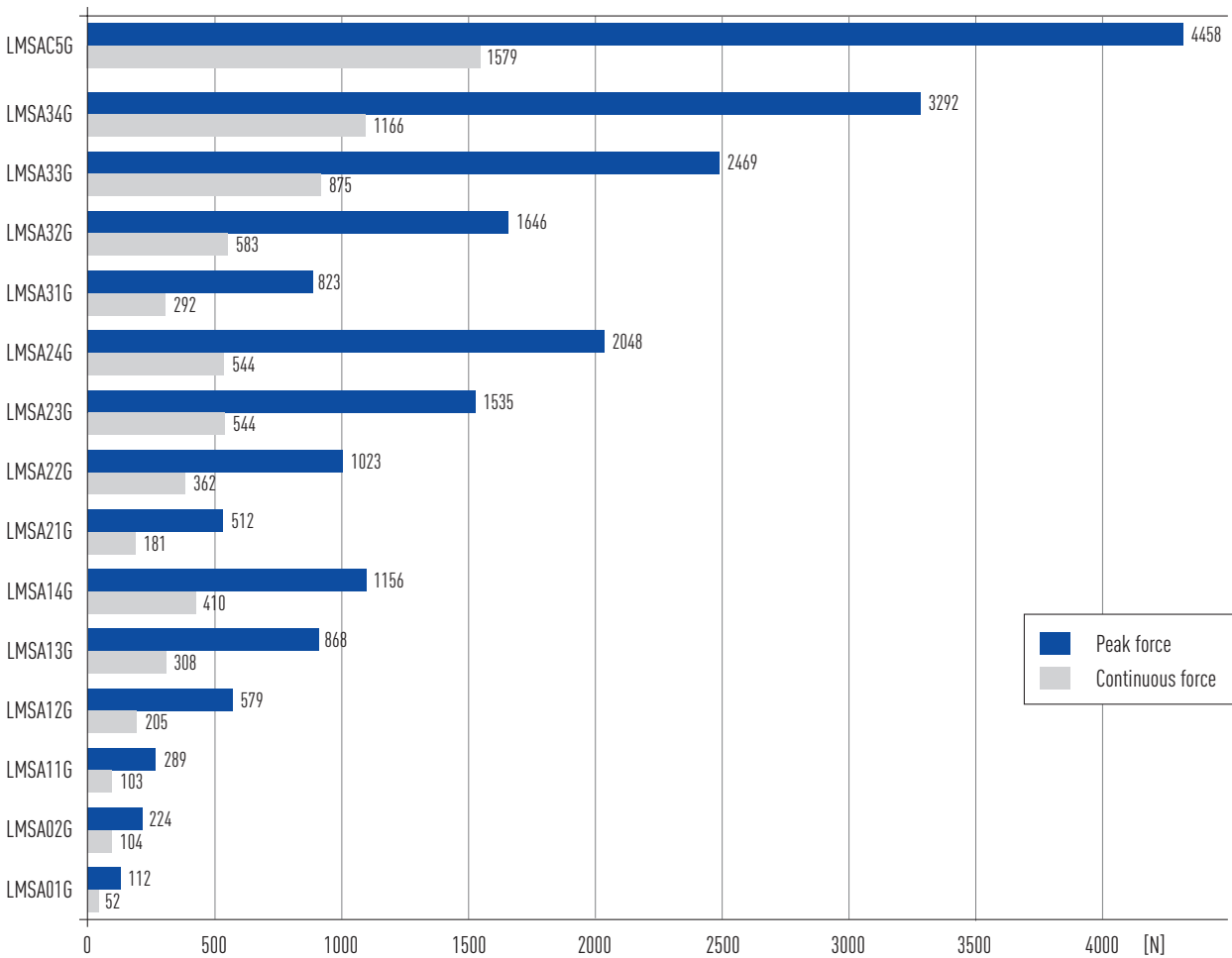

2.3 Order code LMSA linear motors

2.3.1 Order code of primary part (forcer)

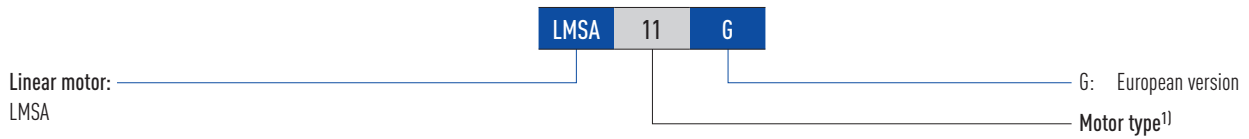

¹⁾ See Table 2.1 (LMSA0)
Table 2.3 (LMSA1)
Table 2.5 (LMSA2)
Table 2.7 (LMSA3)
Table 2.9 (LMSAC)

2.3.2 Order code of magnet track (stator)

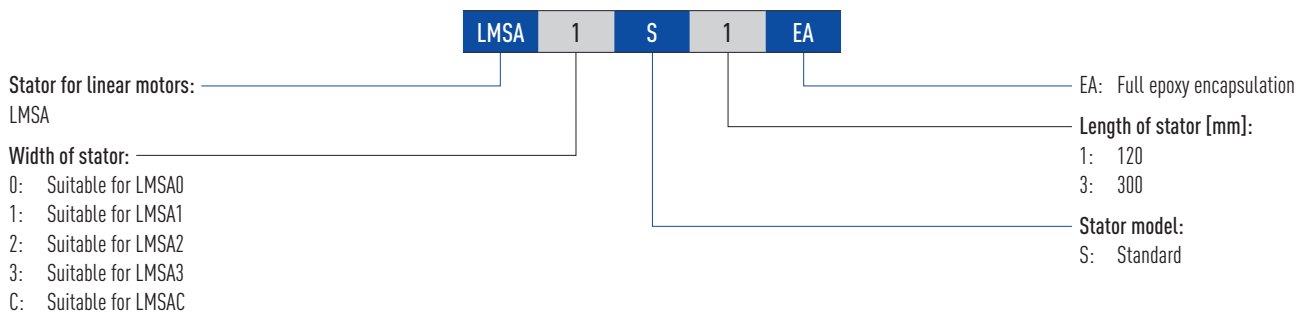

Linear Motors & Distance Measuring Systems

HIWIN LMSA linear motors

2.4 LMSA linear motor specifications

2.4.1 LMSA0 linear motor specifications

Force-velocity curves (DC bus voltage: 600 VDC)

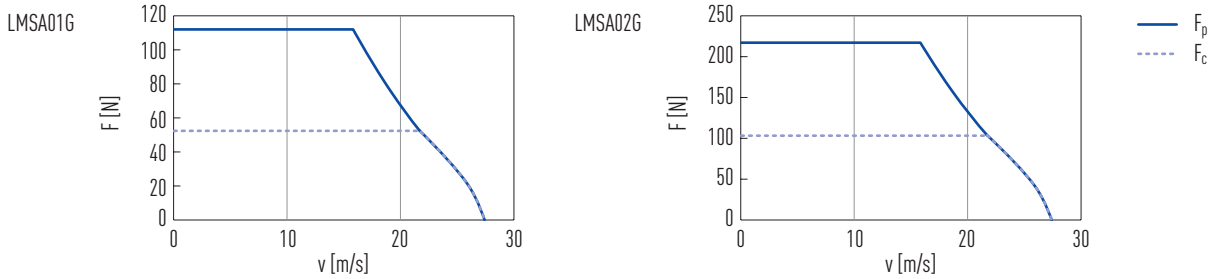
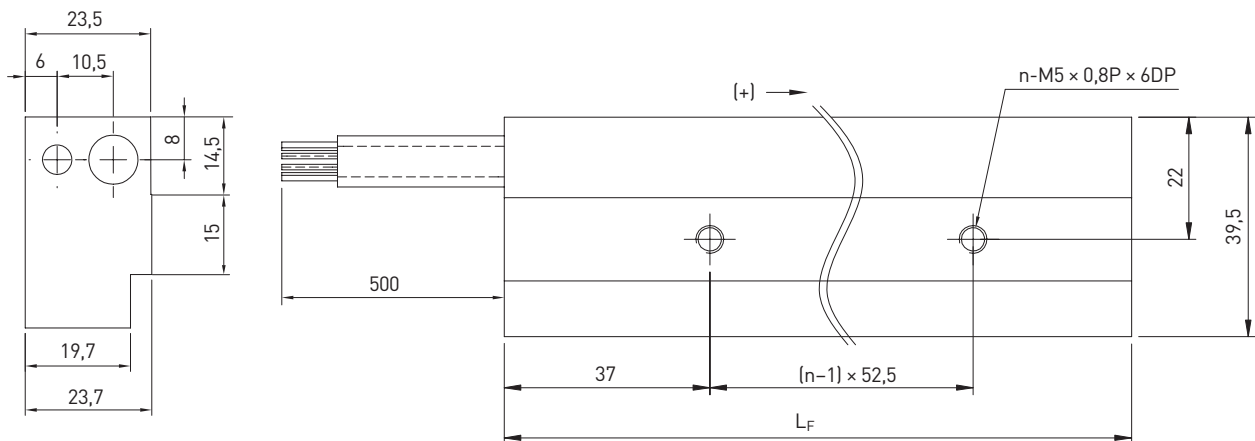

Table 2.1 Technical data for LMSA0

	Symbol	Unit	LMSA01G	LMSA02G
Forces and electrical parameters				
Continuous force at T_{max}	F_c	N	52	104
Continuous current at T_{max}	I_c	A_{eff}	2.1	4.2
Peak force (for 1 s)	F_p	N	112	224
Peak current (for 1 s)	I_p	A_{eff}	6.3	12.6
Ultimate force (for 0.5 s)	F_u	N	143	286
Ultimate current (for 0.5 s)	I_u	A_{eff}	10.6	21.1
Force constant	K_f	N/A_{eff}	24.5	24.5
Attraction force	F_a	N	241	482
Electrical time constant	K_e	ms	3.0	3.7
Resistance ¹⁾	R_{25}	Ω	6.2	3.1
Inductance ¹⁾	L	mH	23	11.6
Back EMF constant	K_u	$V_{eff}/(m/s)$	14.2	14.2
Motor constant	K_m	N/\sqrt{W}	8.1	11.5
Thermal resistance	R_{th}	$^{\circ}C/W$	1.69	0.83
Thermal time constant	T_{th}	s	431	610
Thermal switch			1 × PT1000 + 1 × (3 PTC SNM 120 in series)	
Max. DC bus voltage		V	750	
Mechanical parameters				
Max. bending radius of motor cable	R_{bend}	mm	69	
Pole pair pitch	2τ	mm	30	
Max. winding temperature	T_{max}	$^{\circ}C$	120	
Mounting holes (forcer)	n		2	4
Weight of forcer	M_f	kg	0.49	0.98
Length of forcer	L_f	mm	118	223
Unit mass of stator	M_s	kg/m	1.9	
Stator length/Dimension N	L_s	mm	120 mm/N = 2; 300 mm/N = 5	
Total height (forcer + stator)	H	mm	34	

All specifications are in $\pm 10\%$ of tolerance at 25 $^{\circ}C$ ambient temperature ¹⁾ Line to line

Dimensions of forcer



Dimensions of stator

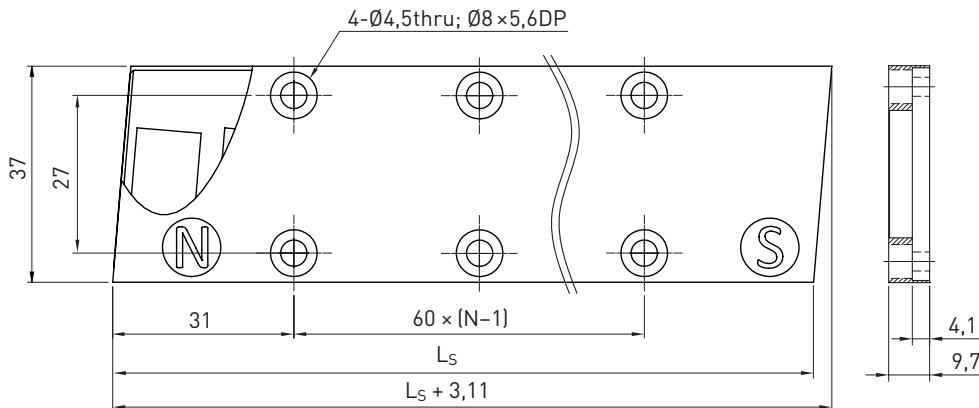

Mounting tolerances

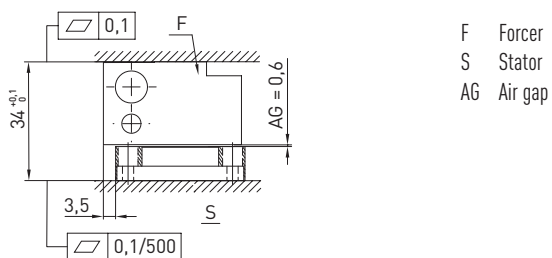

Table 2.2 LMSA1 motor cable assignment

Motor cable	Signal	Diameter [mm]		
1	U	9.2		
2	V			
3	W			
Green/Yellow	GND			
Yellow	T1+	PTC SNM 120	5.5	
Green	T1-			
Brown	T2+			PT1000
White	T2-			

Linear Motors & Distance Measuring Systems

HIWIN LMSA linear motors

2.4.2 LMSA1 linear motor specifications

Force-velocity curves (DC bus voltage: 600 VDC)

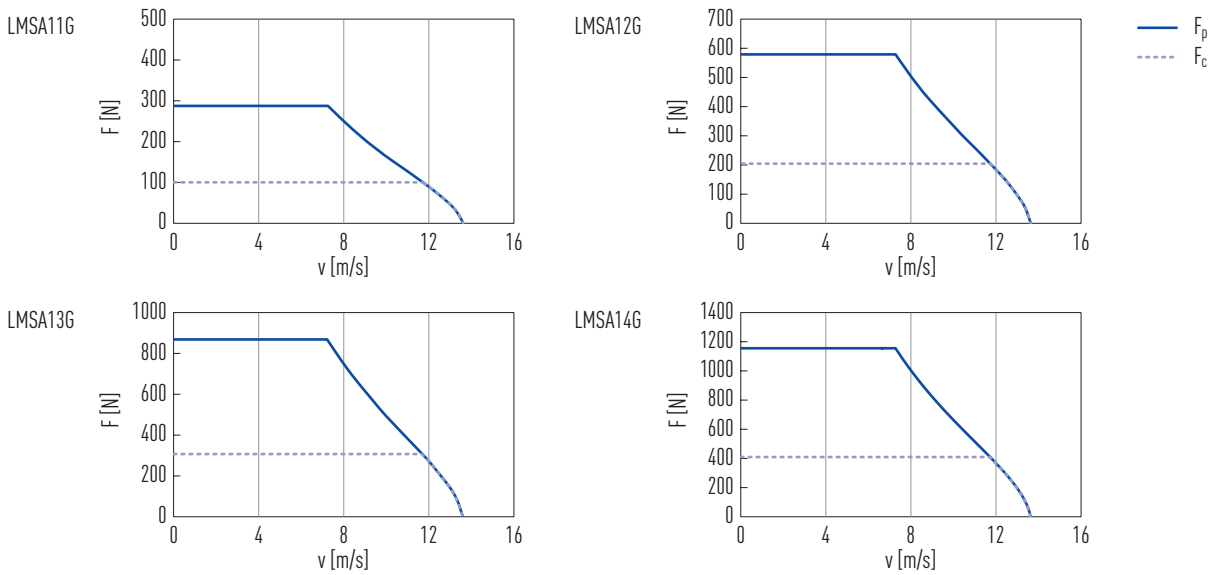
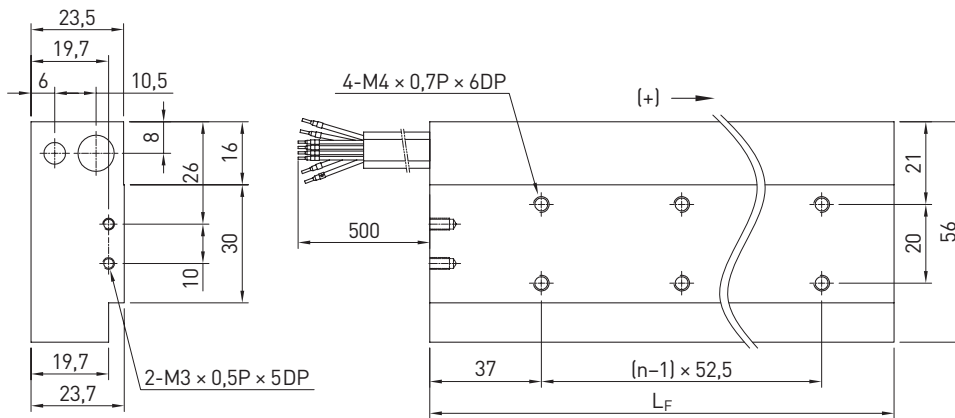

Table 2.3 Technical data for LMSA1

	Symbol	Unit	LMSA116	LMSA126	LMSA136	LMSA146
Forces and electrical parameters						
Continuous force at T_{max}	F_c	N	103	205	308	410
Continuous current at T_{max}	I_c	A_{eff}	2.1	4.2	6.3	8.4
Peak force (for 1 s)	F_p	N	289	579	868	1,156
Peak current (for 1 s)	I_p	A_{eff}	6.3	12.7	19.0	25.3
Ultimate force (for 0.5 s)	F_u	N	379	759	1,138	1,517
Ultimate current (for 0.5 s)	I_u	A_{eff}	10.6	21.1	31.7	42.2
Force constant	K_f	N/A_{eff}	48.6	48.6	48.6	48.6
Attraction force	F_a	N	481	963	1,444	1,926
Electrical time constant	K_e	ms	4.4	4.5	4.4	4.4
Resistance ¹⁾	R_{25}	Ω	8.4	4.1	2.8	2.1
Inductance ¹⁾	L	mH	37.1	18.5	12.4	9.3
Back EMF constant	K_u	$V_{eff}/(m/s)$	28.1	28.1	28.1	28.1
Motor constant	K_{m}	N/\sqrt{W}	13.7	19.6	23.7	27.4
Thermal resistance	R_{th}	$^{\circ}C/W$	1.23	0.63	0.41	0.31
Thermal time constant	T_{th}	s	610	890	2,290	4,430
Thermal switch			1 × PT1000 + 1 × (3 PTC SNM 120 in series)			
Max. DC bus voltage		V	750			
Mechanical parameters						
Max. bending radius of motor cable	R_{bend}	mm	69			
Pole pair pitch	2τ	mm	30			
Max. winding temperature	T_{max}	$^{\circ}C$	120			
Mounting holes (forcer)	n		2	4	6	8
Weight of forcer	M_f	kg	0.7	1.4	2.1	2.8
Length of forcer	L_f	mm	118	223	328	433
Unit mass of stator	M_s	kg/m	2.7			
Stator length/Dimension N	L_s	mm	120 mm/N = 2; 300 mm/N = 5			
Total height (forcer + stator)	H	mm	34			

All specifications are in $\pm 10\%$ of tolerance at 25 $^{\circ}C$ ambient temperature ¹⁾ Line to line

Dimensions of forcer



Dimensions of stator

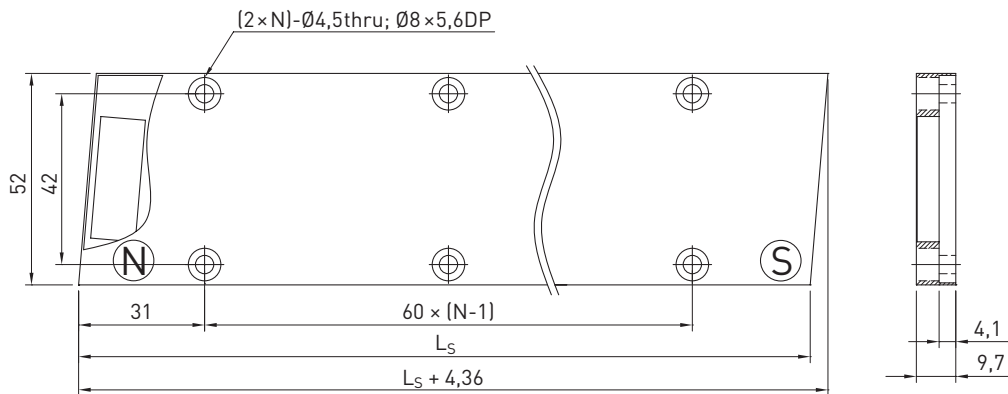

Mounting tolerances

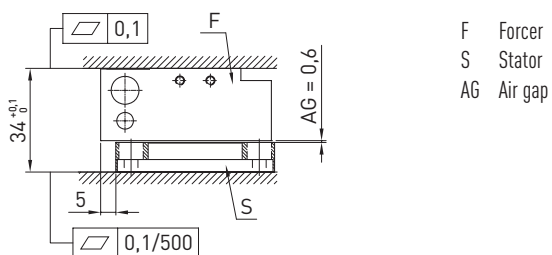

Table 2.4 LMSA1 motor cable assignment

Motor cable	Signal	Diameter [mm]	
1	U	9.2	
2	V		
3	W		
Green/Yellow	GND	5.5	
Yellow	T1+		PTC SNM 120
Green	T1-		PT1000
Brown	T2+		
White	T2-		

Linear Motors & Distance Measuring Systems

HIWIN LMSA linear motors

2.4.3 LMSA2 linear motor specifications

Force-velocity curves (DC bus voltage: 600 VDC)

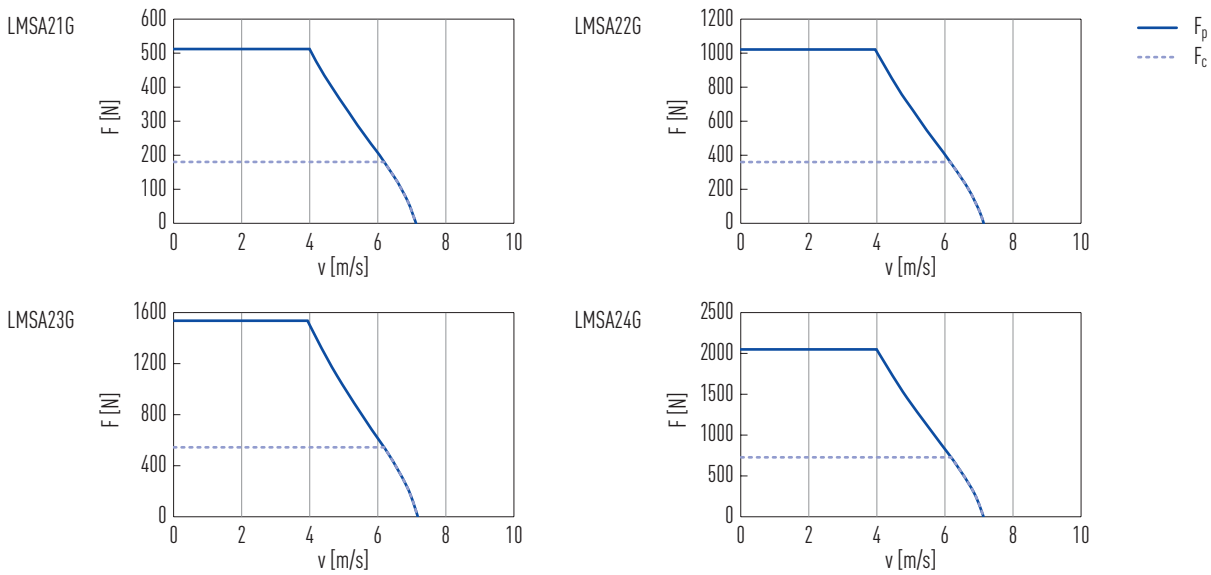

Table 2.5 Technical data for LMSA2

	Symbol	Unit	LMSA21G	LMSA22G	LMSA23G	LMSA24G
Forces and electrical parameters						
Continuous force at T_{max}	F_c	N	181	362	544	725
Continuous current at T_{max}	I_c	A_{eff}	2.0	3.9	5.9	7.8
Peak force (for 1 s)	F_p	N	512	1,023	1,535	2,048
Peak current (for 1 s)	I_p	A_{eff}	5.9	11.8	17.6	23.5
Ultimate force (for 0.5 s)	F_u	N	670	1,341	2,011	2,682
Ultimate current (for 0.5 s)	I_u	A_{eff}	9.8	19.6	29.4	39.2
Force constant	K_f	N/A_{eff}	92.5	92.5	92.5	92.5
Attraction force	F_a	N	963	1,926	2,888	3,851
Electrical time constant	K_e	ms	4.6	4.9	4.9	4.6
Resistance ¹⁾	R_{25}	Ω	13.8	6.8	4.6	3.5
Inductance ¹⁾	L	mH	64.0	33.0	22.4	16.0
Back EMF constant	K_u	$V_{eff}/(m/s)$	53.4	53.4	53.4	53.4
Motor constant	K_m	N/\sqrt{W}	20.3	28.9	35.2	40.6
Thermal resistance	R_{th}	$^{\circ}C/W$	0.87	0.44	0.29	0.22
Thermal time constant	T_{th}	s	975	2.540	2.670	3.270
Thermal switch			1 × PT1000 + 1 × [3 PTC SNM 120 in series]			
Max. DC bus voltage		V	750			
Mechanical parameters						
Max. bending radius of motor cable	R_{bend}	mm	69			
Pole pair pitch	2τ	mm	30			
Max. winding temperature	T_{max}	$^{\circ}C$	120			
Mounting holes (forcer)	n		2	4	6	8
Weight of forcer	M_f	kg	1.1	2.2	3.3	4.4
Length of forcer	L_f	mm	118	223	328	433
Unit mass of stator	M_s	kg/m	4.8			
Stator length/mounting holes	L_s	mm	120 mm/N = 2; 300 mm/N = 5			
Total height (forcer + stator)	H	mm	34			

All specifications are in $\pm 10\%$ of tolerance at 25 $^{\circ}C$ ambient temperature

¹⁾ Line to line

Dimensions of forcer

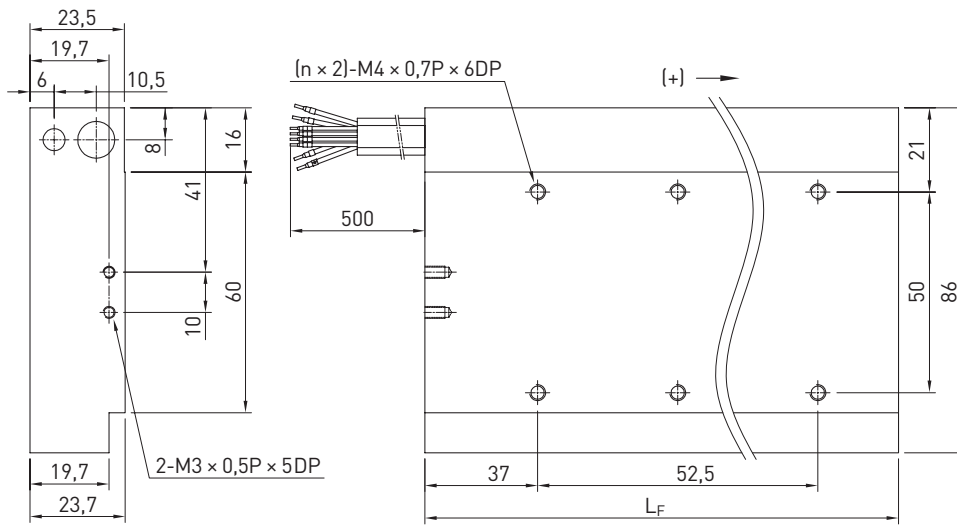

Dimensions of stator

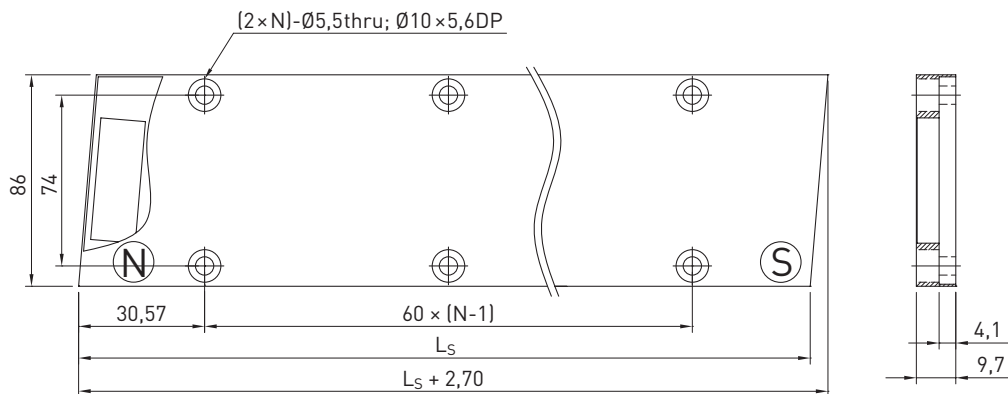

Mounting tolerances

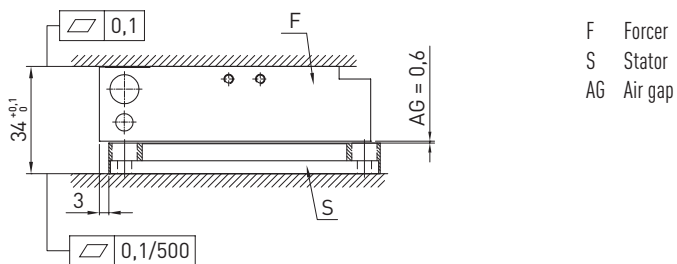

Table 2.6 LMSA2 motor cable assignment

Motor cable	Signal		Diameter [mm]
1	U		9.2
2	V		
3	W		
Green/Yellow	GND		
Yellow	T1+	PTC SNM 120	5.5
Green	T1-		
Brown	T2+	PT1000	
White	T2-		

Linear Motors & Distance Measuring Systems

HIWIN LMSA linear motors

2.4.4 LMSA3 linear motor specifications

Force-velocity curves (DC bus voltage: 600 VDC)

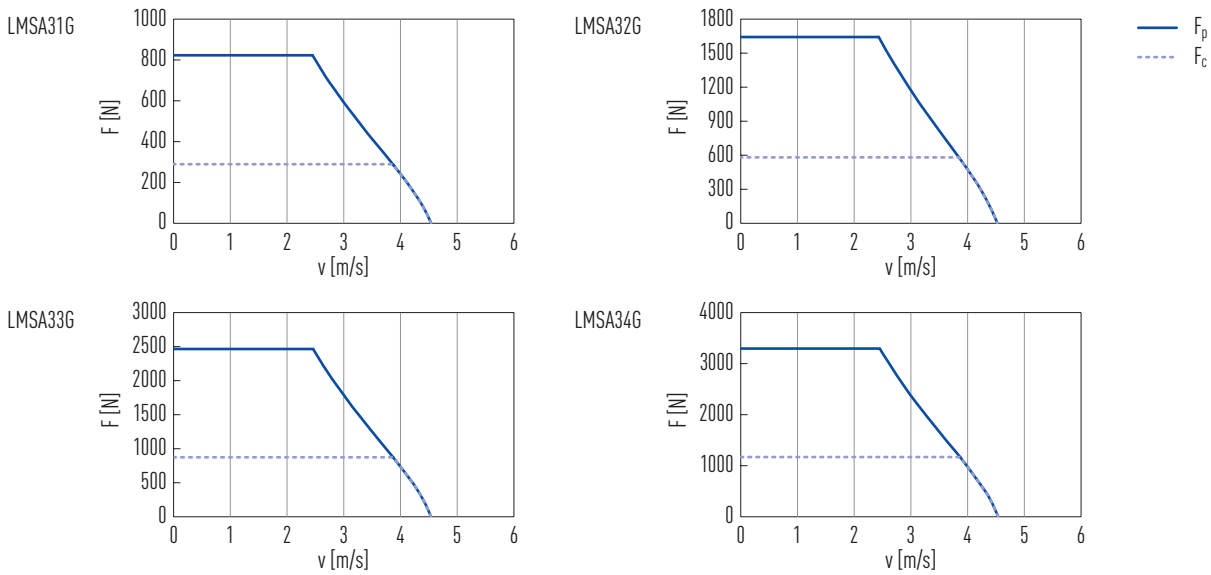

Table 2.7 Technical data for LMSA3

	Symbol	Unit	LMSA31G	LMSA32G	LMSA33G	LMSA34G
Forces and electrical parameters						
Continuous force at T_{max}	F_c	N	292	583	875	1,166
Continuous current at T_{max}	I_c	A_{eff}	2.0	4.0	6.0	8.0
Peak force (for 1 s)	F_p	N	823	1,646	2,469	3,292
Peak current (for 1 s)	I_p	A_{eff}	6.0	12.0	18.0	24.0
Ultimate force (for 0.5 s)	F_u	N	1,079	2,157	3,236	4,314
Ultimate current (for 0.5 s)	I_u	A_{eff}	10.0	20.0	30.0	40.0
Force constant	K_f	N/A_{eff}	145.8	145.8	145.8	145.8
Attraction force	F_a	N	1,444	2,888	4,333	5,777
Electrical time constant	K_e	ms	4.9	4.9	4.9	4.9
Resistance ¹⁾	R_{25}	Ω	19.2	9.6	6.4	4.8
Inductance ¹⁾	L	mH	94.1	47.1	31.3	23.5
Back EMF constant	K_u	$V_{eff}/(m/s)$	84.2	84.2	84.2	84.2
Motor constant	K_m	N/\sqrt{W}	27.2	38.4	47.0	54.3
Thermal resistance	R_{th}	$^{\circ}C/W$	0.60	0.30	0.20	0.15
Thermal time constant	T_{th}	s	1.440	3.060	3.480	4.800
Thermal switch			1 × PT1000 + 1 × [3 PTC SNM 120 in series]			
Max. DC bus voltage		V	750			
Mechanical parameters						
Max. bending radius of motor cable	R_{bend}	mm	69			
Pole pair pitch	2τ	mm	30			
Max. winding temperature	T_{max}	$^{\circ}C$	120			
Mounting holes (forcer)	n		2	4	6	8
Weight of forcer	M_f	kg	1.9	3.8	5.7	7.6
Length of forcer	L_f	mm	118	223	328	433
Unit mass of stator	M_s	kg/m	8.5			
Stator length/mounting holes	L_s	mm	120 mm/N = 2; 300 mm/N = 5			
Total height (forcer + stator)	H	mm	36			

All specifications are in $\pm 10\%$ of tolerance at 25 $^{\circ}C$ ambient temperature

¹⁾ Line to line

Dimensions of forcer

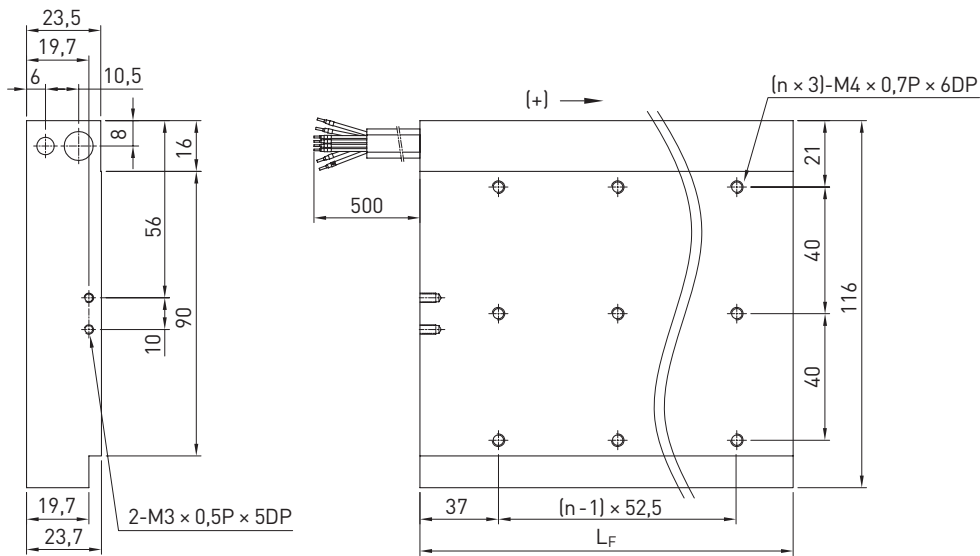

Dimensions of stator

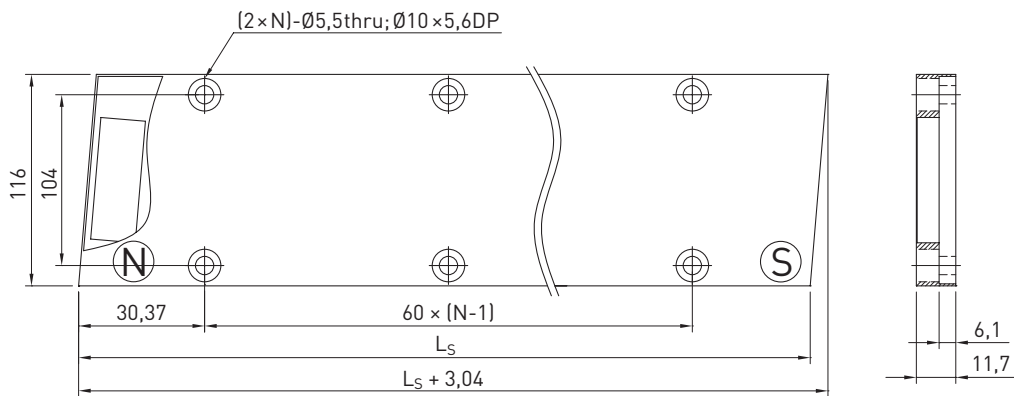

Mounting tolerances

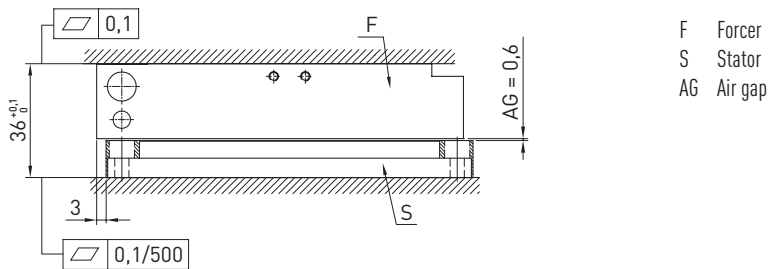

Table 2.8 LMSA3 motor cable assignment

Motor cable	Signal	Diameter [mm]	
1	U	9.2	
2	V		
3	W		
Green/Yellow	GND	5.5	
Yellow	T1+		PTC SNM 120
Green	T1-		
Brown	T2+		PT1000
White	T2-		

Linear Motors & Distance Measuring Systems

HIWIN LMSA linear motors

2.4.5 LMSAC linear motor specifications

Force-velocity curves (DC bus voltage: 600 VDC)

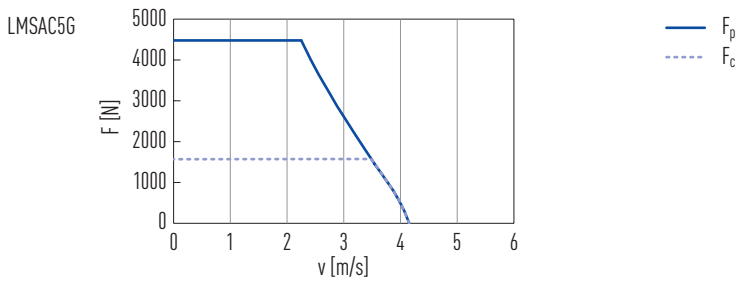

Table 2.9 Technical data for LMSAC

	Symbol	Unit	LMSAC5G
Forces and electrical parameters			
Continuous force at T_{max}	F_c	N	1,579
Continuous current at T_{max}	I_c	A_{eff}	10.0
Peak force (for 1 s)	F_p	N	4,458
Peak current (for 1 s)	I_p	A_{eff}	30.0
Ultimate force (for 0.5 s)	F_u	N	5,842
Ultimate current (for 0.5 s)	I_u	A_{eff}	50.0
Force constant	K_f	N/A_{eff}	157.9
Attraction force	F_a	N	7,823
Electrical time constant	K_e	ms	5.0
Resistance ¹⁾	R_{25}	Ω	4.1
Inductance ¹⁾	L	mH	20.3
Back EMF constant	K_u	$V_{eff}/(m/s)$	91.2
Motor constant	K_m	N/\sqrt{W}	63.7
Thermal resistance	R_{th}	$^{\circ}C/W$	0.11
Thermal time constant	T_{th}	s	4,530
Thermal switch			1 \times PT1000 + 1 \times (3 PTC SNM 120 in Serie)
Max. DC bus voltage		V	750
Mechanical parameters			
Max. bending radius of motor cable	R_{bend}	mm	69
Pole pair pitch	2τ	mm	30
Max. winding temperature	T_{max}	$^{\circ}C$	120
Mounting holes (forcer)	n		10
Weight of forcer	M_F	kg	10.5
Length of forcer	L_F	mm	538
Unit mass of stator	M_S	kg/m	9.7
Stator length/mounting holes	L_S	mm	120 mm/N = 2; 300 mm/N = 5
Total height (forcer + stator)	H	mm	36

All specifications are in $\pm 10\%$ of tolerance at 25 $^{\circ}C$ ambient temperature

¹⁾ Line to line

Dimensions of forcer

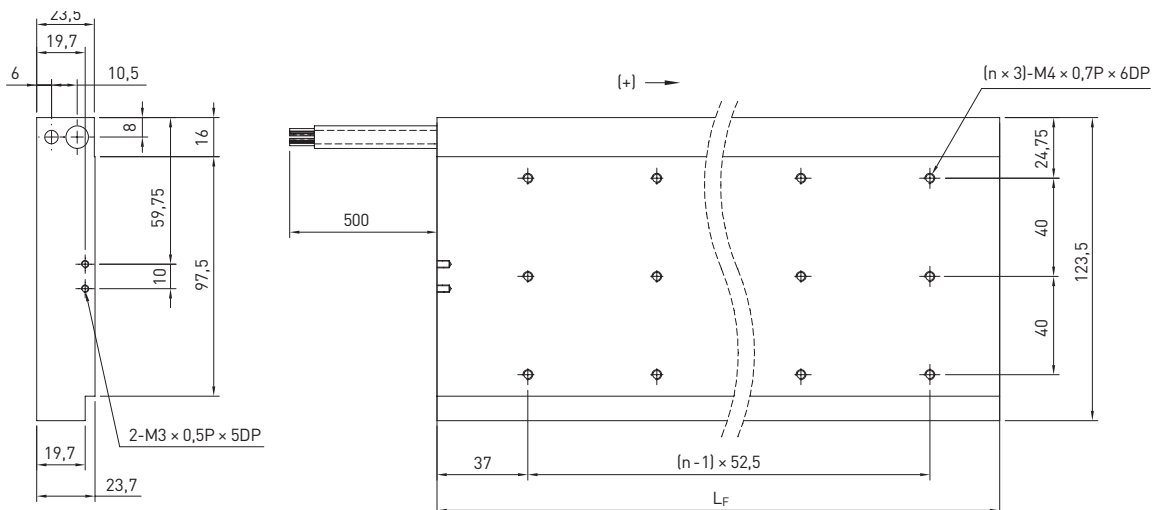

Dimensions of stator

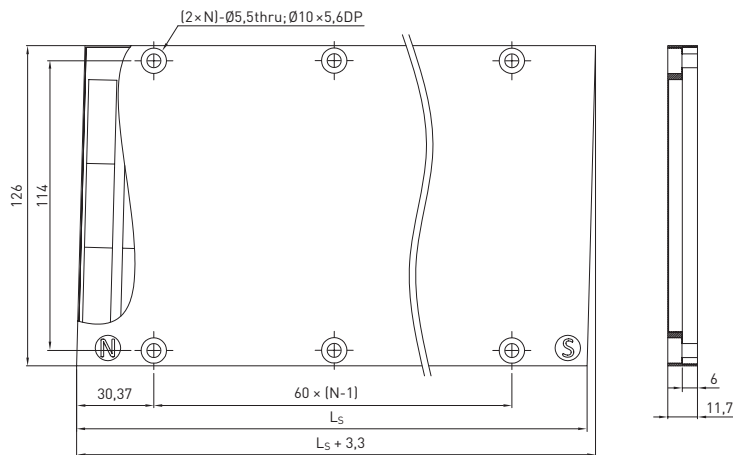

Mounting tolerances

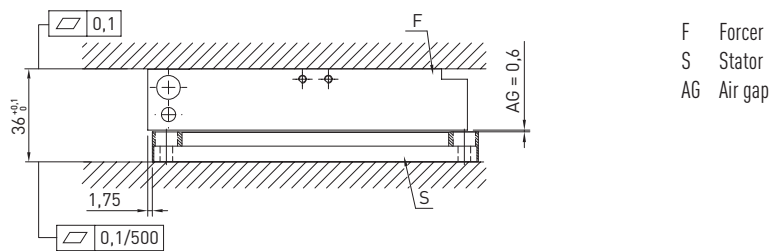

Table 2.10 LMSA3 motor cable assignment

Motor cable	Signal		Diameter [mm]
1	U		9.2
2	V		
3	W		
Green/Yellow	GND		5.5
Yellow	T1+	PTC SNM 120	
Green	T1-		
Brown	T2+	PT1000	
White	T2-		

Linear Motors & Distance Measuring Systems

HIWIN LMC linear motors

3. HIWIN LMC linear motors

3.1 Special characteristics of the LMC linear motors

The HIWIN LMC synchronous linear motors are the dynamic sprinters of linear actuators. With the light, ironlessforcer and the U-shaped design of the stators with opposing magnets, no cogging torques occur between forcers and stators, and no magnetic forces are introduced into the guiding system. The linear motors in the LMC series thus achieve extremely high synchronism and high acceleration due to the minimal forcer mass. The LMC linear motors are optionally available as a vacuum system. The benefits of the LMC linear motors make them the preferred choice in fields where small masses with a maximum number of cycles need to be positioned very precisely. Due to their very high synchronism, the LMC linear motors are also suitable for application in testing and measuring machines.



Key features of the LMC linear motors:

- Extremely dynamic
- No cogging, thus highest synchronous operation
- No magnetic pull in the guiding system
- Optional: design for vacuum applications
- Optional: version with Hall sensor

Typical fields of application of the LMC linear motors:

- Pick-and-place machines in semiconductor technology
- Air bearing axes
- Wafer structuring
- Pick-and-place machines
- High-precision measuring and testing machines
- Semiconductors

3.2 Force chart for LMC linear motors

Force chart for linear motors LMCA, LMCA, LMCC

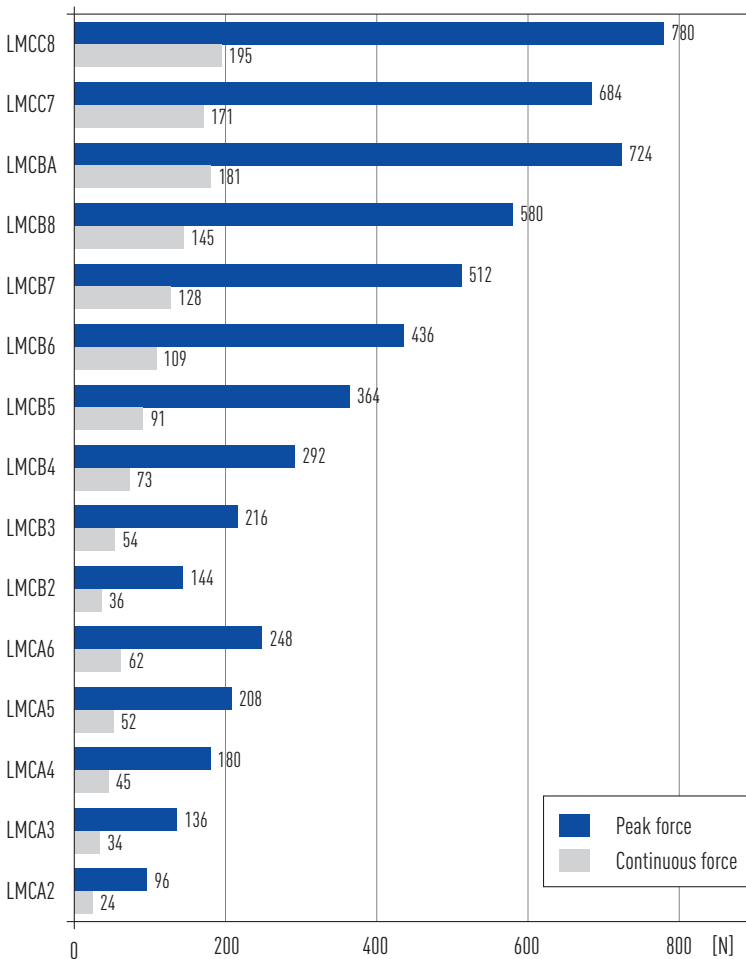

Force chart for linear motors LMCE

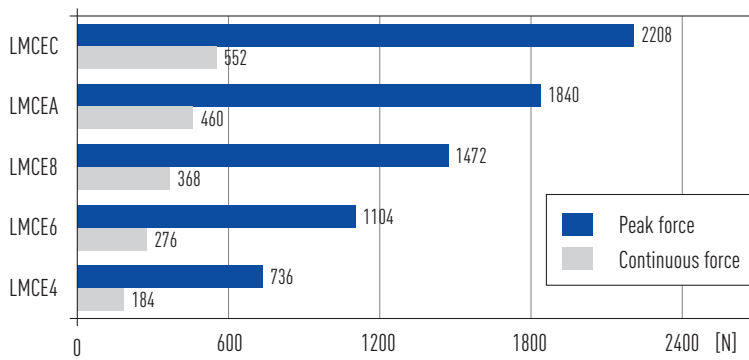

3.3 Order code LMC linear motors

3.3.1 Order code of primary part (forcer)

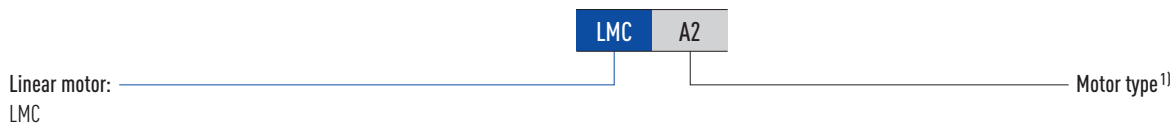

¹⁾ See Table 3.1 (LMCA)
 Table 3.3 (LMCB)
 Table 3.5 (LMCC)
 Table 3.7 (LMCE)

3.3.2 Order code of magnet track (stator)

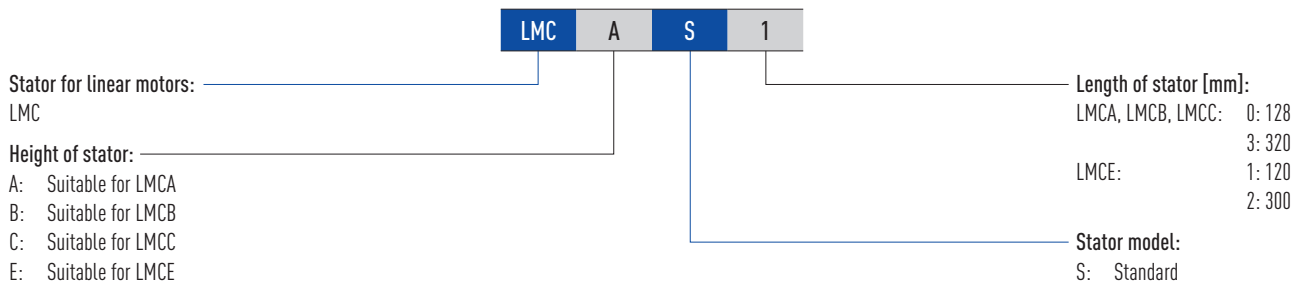

Linear Motors & Distance Measuring Systems

HIWIN LMC linear motors

3.4 LMC linear motor specifications

3.4.1 LMCA linear motor specifications

Force-velocity curves (DC bus voltage: 330 VDC)

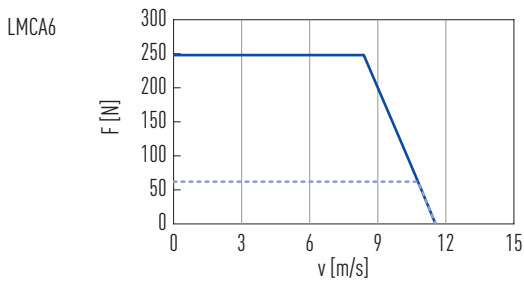
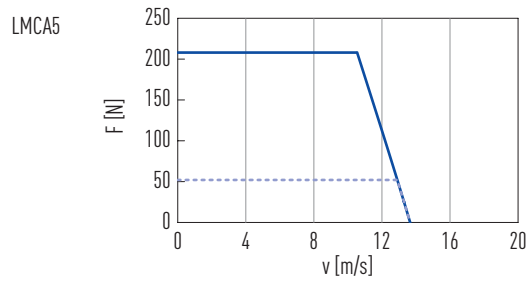
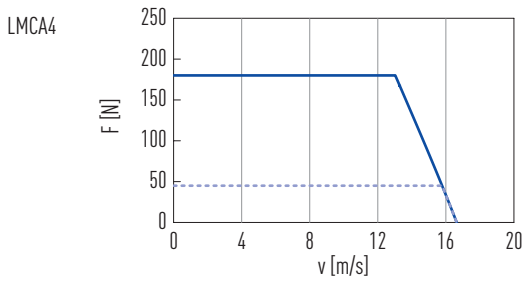
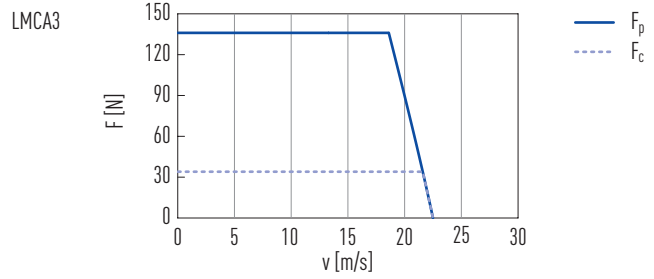
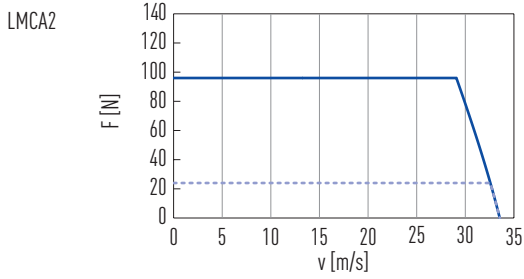

Table 3.1 Technical data for LMCA

	Symbol	Unit	LMCA2	LMCA3	LMCA4	LMCA5	LMCA6
Forces and electrical parameters							
Continuous force at T_{max}	F_c	N	24	34	45	52	62
Continuous current at T_{max}	I_c	A_{eff}	2.3	2.1	2.1	1.8	1.8
Peak force (for 1 s)	F_p	N	96	136	180	208	248
Peak current (for 1 s)	I_p	A_{eff}	9.2	8.4	8.4	7.2	7.2
Force constant	K_f	N/A_{eff}	10.6	15.8	21.2	28.2	33.8
Electrical time constant	K_e	ms	0.4	0.3	0.3	0.3	0.3
Resistance ¹⁾	R_{25}	Ω	2.7	4.1	5.4	6.7	8.2
Inductance ¹⁾	L	mH	1.0	1.4	1.9	2.3	2.8
Back EMF constant	K_u	$V_{eff}/(m/s)$	5.9	8.8	11.9	14.5	17.4
Motor constant	K_m	N/\sqrt{W}	5.2	6.5	7.5	9.1	9.8
Thermal resistance	R_{th}	$^{\circ}C/W$	2.80	2.21	1.68	1.84	1.50
Thermal switch			3 PTC SNM 100 in series				
Max. DC bus voltage		V	330				
Mechanical parameters							
Max. bending radius of motor cable	R_{bend}	mm	37.5				
Pole pair pitch	2τ	mm	32				
Max. winding temperature	T_{max}	$^{\circ}C$	100				
Mounting holes (forcer)	n		2	3	4	5	6
Weight of forcer	M_f	kg	0.15	0.23	0.31	0.38	0.45
Length of forcer	L_f	mm	66	98	130	162	194
Unit mass of stator	M_s	kg/m	7				
Stator length/mounting holes	L_s	mm	128 mm/N = 2; 320 mm/N = 5				

All specifications are in $\pm 10\%$ of tolerance at $25^{\circ}C$ ambient temperature

¹⁾ Line to line

Table 3.2 LMCA motor cable assignment

Motor cable	Signal	Diameter [mm]
Brown	U	7.5
White	V	
Grey	W	
Black	GND	
Yellow	T+	
Green	T-	

Linear Motors & Distance Measuring Systems

HIWIN LMC linear motors

Dimensions of forcer

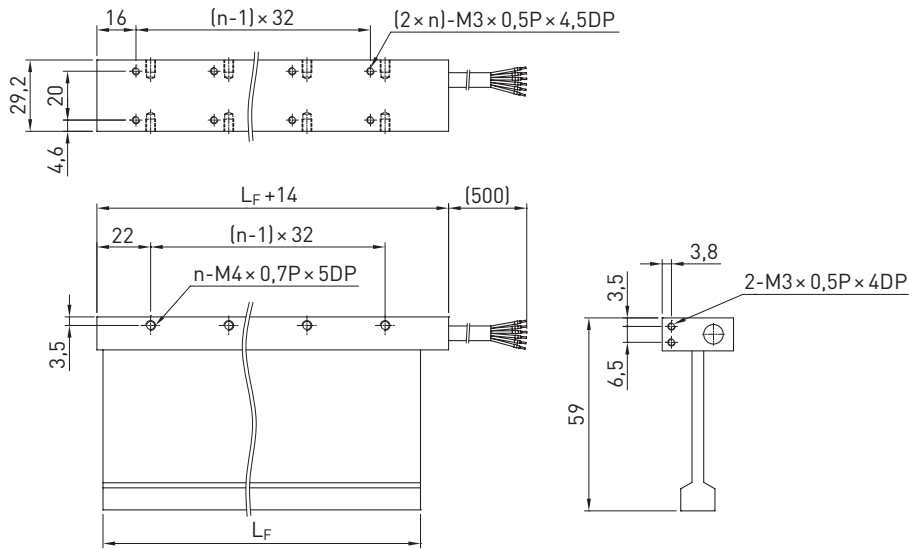

Dimensions of stator

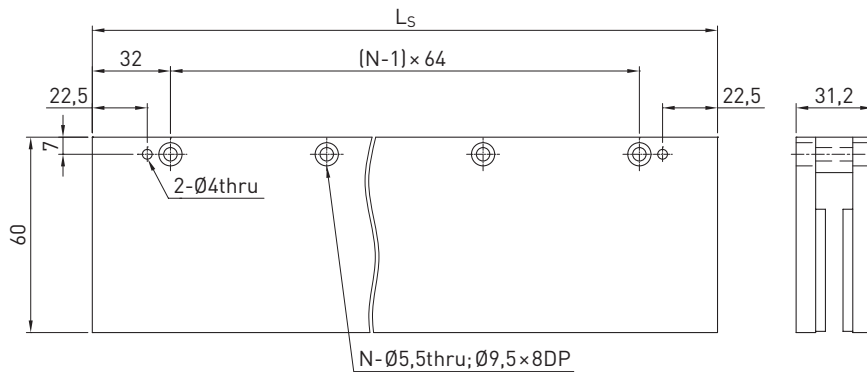

Mounting tolerances

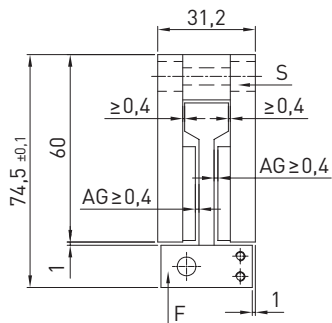

- F Forcer
- S Stator
- AG Air gap

3.4.2 LMCB linear motor specifications

Force-velocity curves (DC bus voltage: 330 VDC)

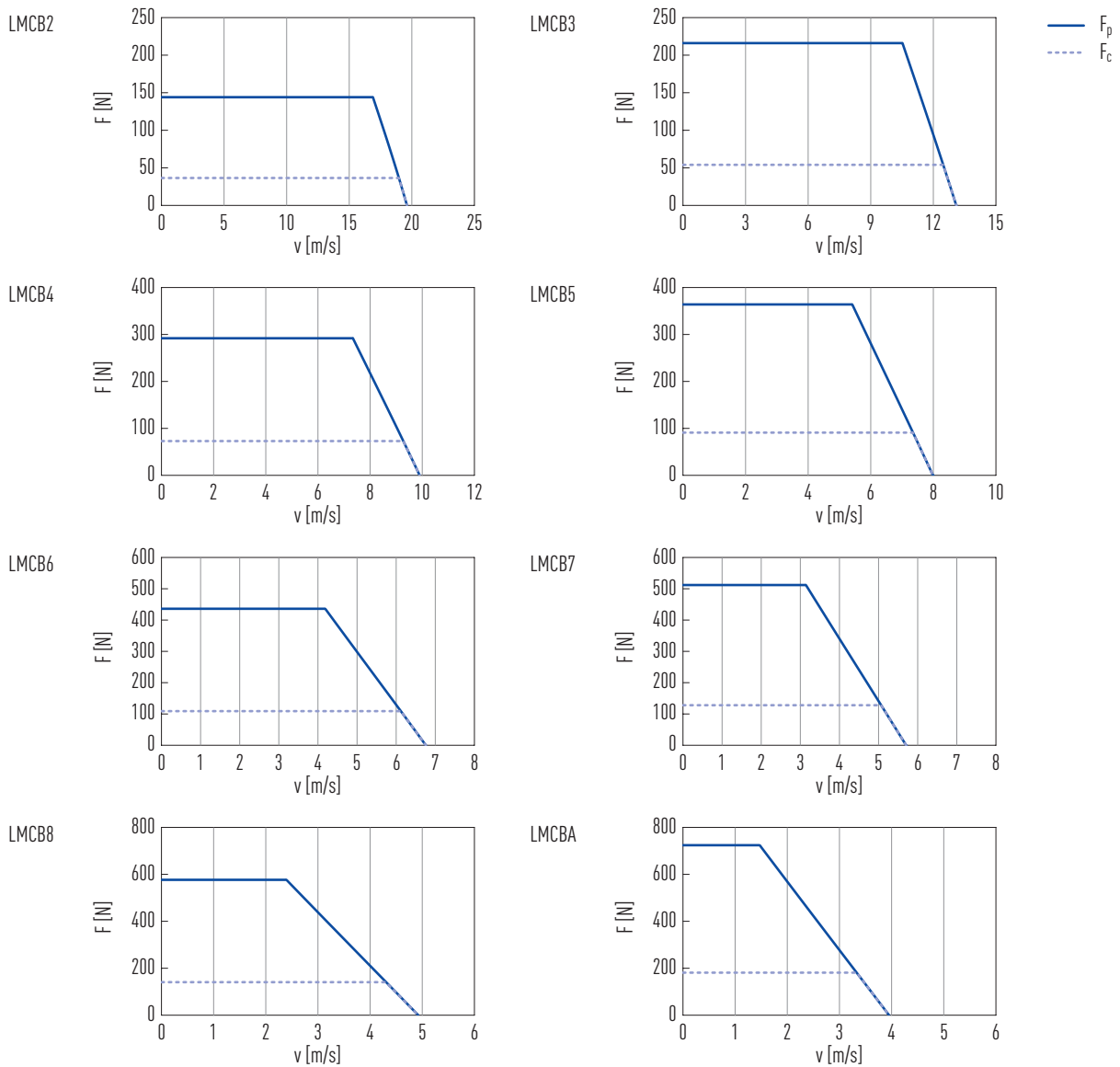

Linear Motors & Distance Measuring Systems

HIWIN LMC linear motors

	Symbol	Unit	LMCB2	LMCB3	LMCB4	LMCB5	LMCB6	LMCB7	LMCB8	LMCBA
Forces and electrical parameters										
Continuous force at T_{max}	F_c	N	36	54	73	91	109	128	145	181
Continuous current at T_{max}	I_c	A_{eff}	2.0	2.0	2.0	2.0	2.0	2.0	2.0	2.0
Peak force (for 1 s)	F_p	N	144	216	292	364	436	512	580	724
Peak current (for 1 s)	I_p	A_{eff}	8.0	8.0	8.0	8.0	8.0	8.0	8.0	8.0
Force constant	K_f	N/A_{eff}	18.1	27.2	36.3	45.4	54.5	63.5	72.5	90.6
Electrical time constant	K_e	ms	0.4	0.4	0.4	0.4	0.4	0.3	0.3	0.3
Resistance ¹⁾	R_{25}	Ω	3.6	5.4	7.1	9.0	10.7	12.6	14.6	17.9
Inductance ¹⁾	L	mH	1.4	1.9	2.6	3.2	3.8	4.4	5.0	6.2
Back EMF constant	K_u	$V_{eff}/(m/s)$	10.1	15.2	20.0	24.8	29.3	34.7	40.0	50.0
Motor constant	K_m	N/\sqrt{W}	7.7	9.5	11.2	12.4	13.6	14.7	15.5	17.5
Thermal resistance	R_{th}	$^{\circ}C/W$	2.77	1.85	1.41	1.11	0.93	0.79	0.68	0.56
Thermal switch			3 PTC SNM 100 in series							
Max. DC bus voltage		V	330							
Mechanical parameters										
Max. bending radius of motor cable	R_{bend}	mm	37.5							
Pole pair pitch	2τ	mm	32							
Max. winding temperature	T_{max}	$^{\circ}C$	100							
Mounting holes (forcer)	n		2	3	4	5	6	7	8	10
Weight of forcer	M_f	kg	0.20	0.29	0.38	0.48	0.58	0.68	0.72	0.88
Length of forcer	L_f	mm	66	98	130	162	194	226	258	322
Unit mass of stator	M_s	kg/m	12							
Stator length/mounting holes	L_s	mm	128 mm/N = 2; 320 mm/N = 5							

All specifications are in $\pm 10\%$ of tolerance at $25^{\circ}C$ ambient temperature

¹⁾ Line to line

Motor cable	Signal	Diameter [mm]
Brown	U	7.5
White	V	
Grey	W	
Black	GND	
Yellow	T+	
Green	T-	

Dimensions of forcer

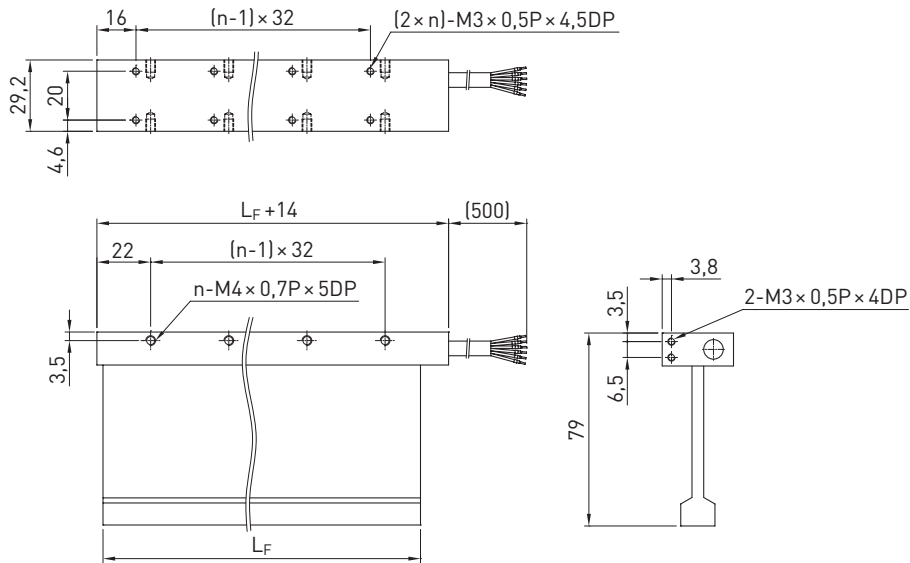

Dimensions of stator

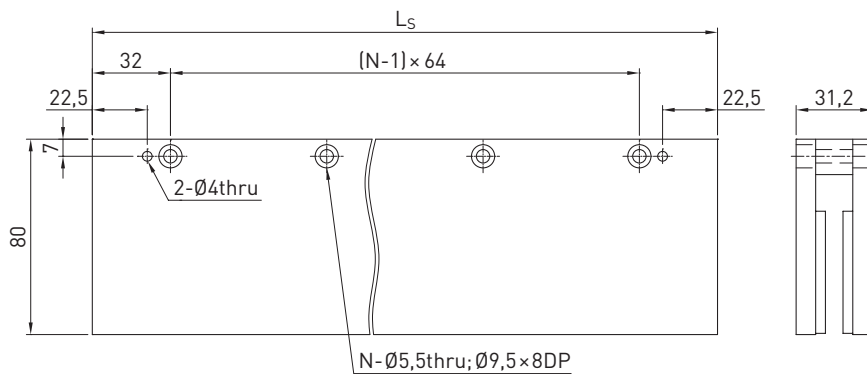

Mounting tolerances

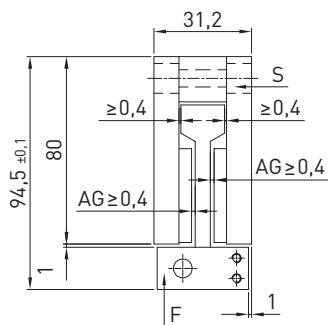

F Forcer
S Stator
AG Air gap

Linear Motors & Distance Measuring Systems

HIWIN LMC linear motors

3.4.3 LMCC linear motor specifications

Force-velocity curves (DC bus voltage: 330 VDC)

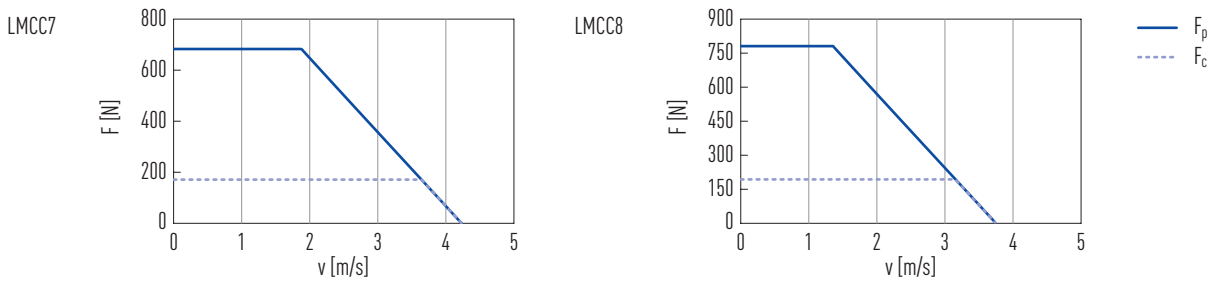

Table 3.5 Technical data for LMCC

	Symbol	Unit	LMCC7	LMCC8
Forces and electrical parameters				
Continuous force at T_{max}	F_c	N	171	195
Continuous current at T_{max}	I_c	A_{eff}	2.0	2.0
Peak force (for 1 s)	F_p	N	684	780
Peak current (for 1 s)	I_p	A_{eff}	8.0	8.0
Force constant	K_f	N/A_{eff}	85.4	97.5
Electrical time constant	K_e	ms	0.3	0.3
Resistance ¹⁾	R_{25}	Ω	15.8	18.2
Inductance ¹⁾	L	mH	5.5	6.3
Back EMF constant	K_v	$V_{eff}/(m/s)$	45.4	51.9
Motor constant	K_m	N/\sqrt{W}	17.6	18.7
Thermal resistance	R_{th}	$^{\circ}C/W$	0.63	0.55
Thermal switch			3 PTC SNM 100 in series	
Max. DC bus voltage		V	330	
Mechanical parameters				
Max. bending radius of motor cable	R_{bend}	mm	37.5	
Pole pair pitch	2τ	mm	32	
Max. winding temperature	T_{max}	$^{\circ}C$	100	
Mounting holes (forcer)	n		7	8
Weight of forcer	M_f	kg	0.74	0.76
Length of forcer	L_f	mm	226	258
Unit mass of stator	M_s	kg/m	21	
Stator length/mounting holes	L_s	mm	128 mm/N = 2; 320 mm/N = 5	

All specifications are in $\pm 10\%$ of tolerance at $25^{\circ}C$ ambient temperature

¹⁾ Line to line

Table 3.6 LMCC motor cable assignment

Motor cable	Signal	Diameter [mm]
Brown	U	7.5
White	V	
Grey	W	
Black	GND	
Yellow	T+	
Green	T-	

Dimensions of forcer

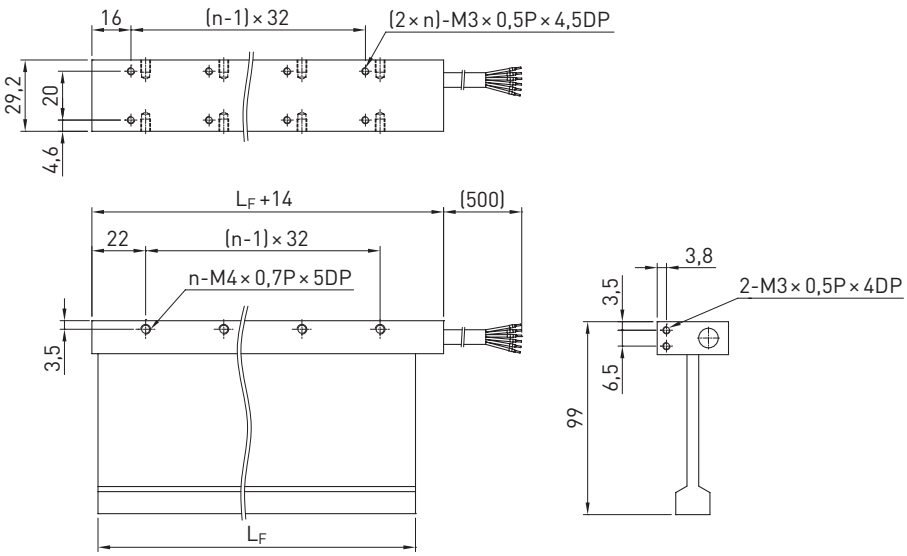

Dimensions of stator

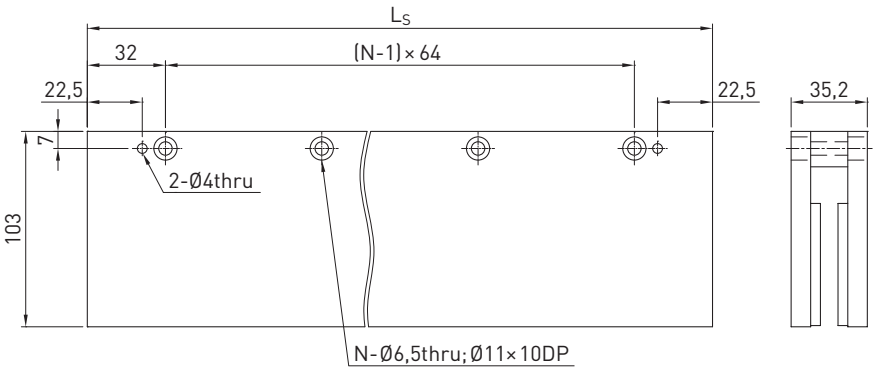

Mounting tolerances

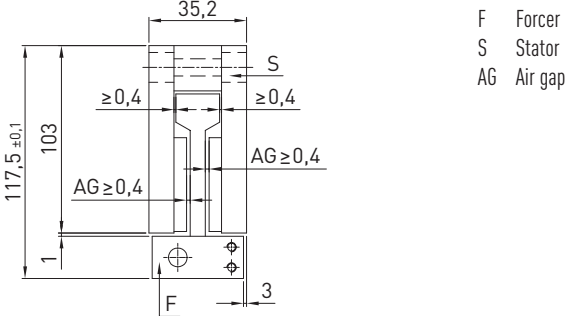

Linear Motors & Distance Measuring Systems

HIWIN LMC linear motors

3.4.4 LMCE linear motor specifications

Force-velocity curves (DC bus voltage: 330 VDC)

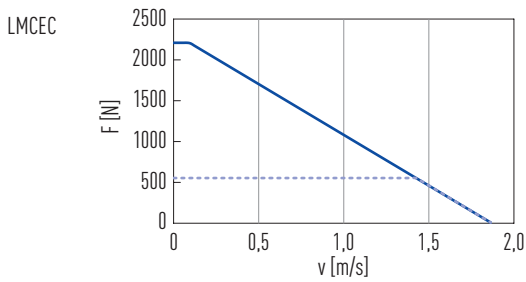
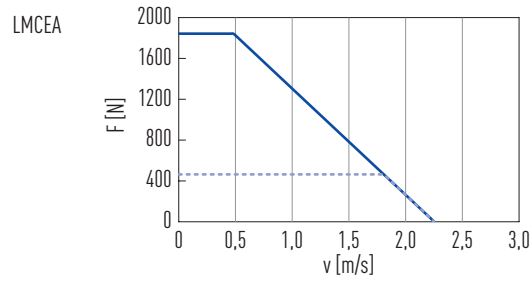
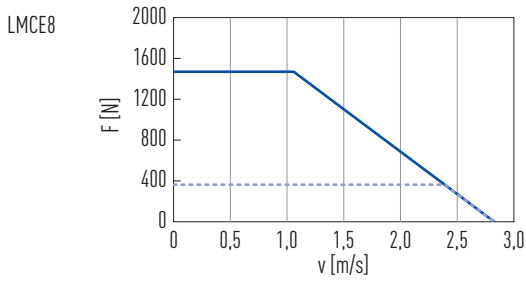
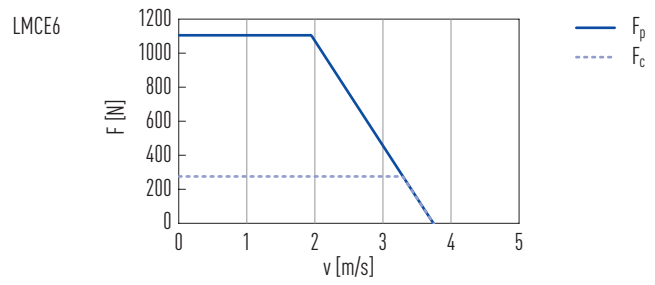
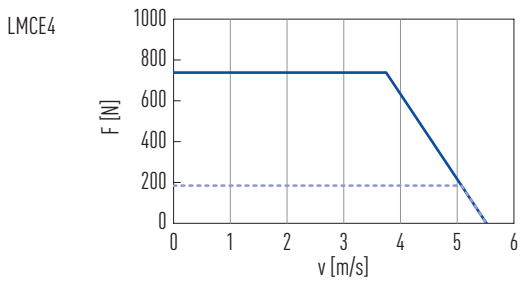

Table 3.7 Technical data for LMCE

	Symbol	Unit	LMCE4	LMCE6	LMCE8	LMCEA	LMCEC
Forces and electrical parameters							
Continuous force at T_{max}	F_c	N	184	276	368	460	552
Continuous current at T_{max}	I_c	A_{eff}	3.25	3.25	3.25	3.25	3.25
Peak force (for 1 s)	F_p	N	736	1,104	1,472	1,840	2,208
Peak current (for 1 s)	I_p	A_{eff}	13	13	13	13	13
Force constant	K_f	N/A_{eff}	56.6	84.9	113.2	141.5	169.8
Electrical time constant	K_e	ms	0.5	0.5	0.5	0.5	0.5
Resistance ¹⁾	R_{25}	Ω	5.6	8.4	11.0	13.8	16.7
Inductance ¹⁾	L	mH	2.9	4.4	5.9	7.3	8.8
Back EMF constant	K_u	$V_{eff}/(m/s)$	35	53	70	88	106
Motor constant	K_m	N/\sqrt{W}	19.1	23.4	27.0	30.2	33.2
Thermal resistance	R_{th}	$^{\circ}C/W$	0.68	0.45	0.34	0.27	0.23
Thermal switch			3 PTC SNM 100 in series				
Max. DC bus voltage		V	330				
Mechanical parameters							
Max. bending radius of motor cable	R_{bend}	mm	37.5				
Pole pair pitch	2τ	mm	60				
Max. winding temperature	T_{max}	$^{\circ}C$	100				
Mounting holes (forcer)	n		7	10	13	16	19
Weight of forcer	M_F	kg	1.23	1.84	2.46	3.08	3.70
Length of forcer	L_F	mm	260	380	500	620	740
Unit mass of stator	M_S	kg/m	20				
Stator length/mounting holes	L_S	mm	120 mm/N = 2; 300 mm/N = 5				

All specifications are in $\pm 10\%$ of tolerance at $25^{\circ}C$ ambient temperature

¹⁾ Line to line

Table 3.8 LMCE motor cable assignment

Motor cable	Signal	Diameter [mm]
Brown	U	7.5
White	V	
Grey	W	
Black	GND	
Yellow	T+	
Green	T-	

Linear Motors & Distance Measuring Systems

HIWIN LMC linear motors

Dimensions offorcer

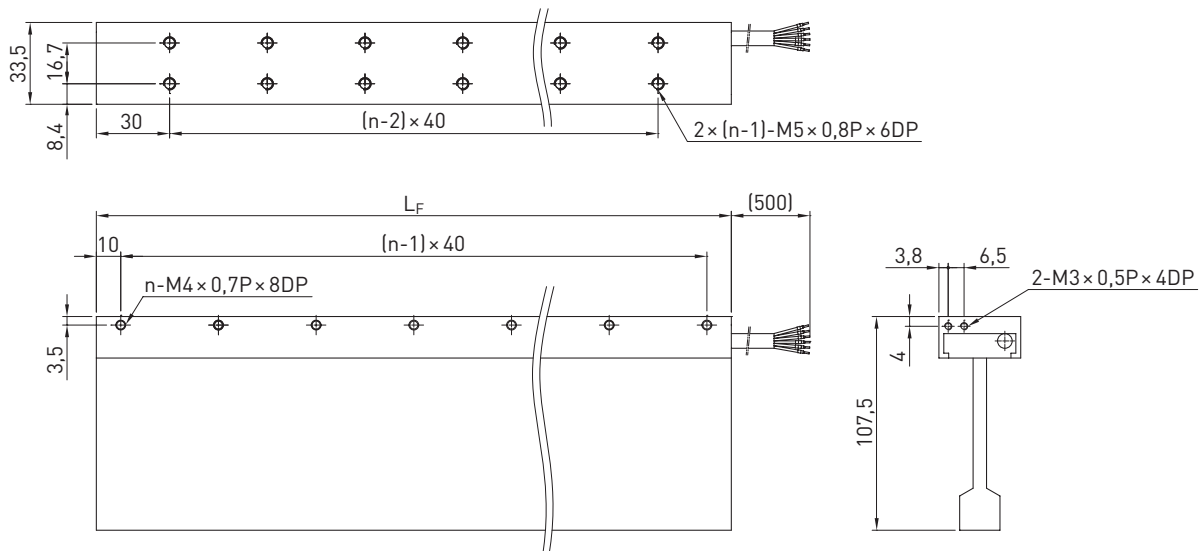

Dimensions of stator

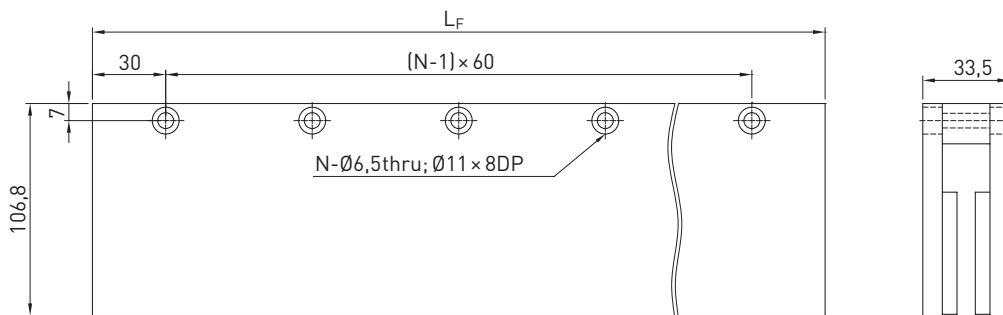

Mounting tolerances

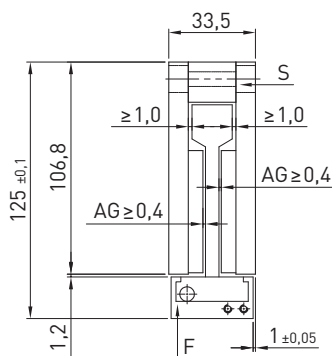

- F Forcer
- S Stator
- AG Air gap

4. HIWIN LMFA linear motors

4.1 Special characteristics of the LMFA linear motors

The HIWIN LMFA synchronous linear motors are the cooled power packs of linear actuators. The UL-certified motors are fitted with a highly efficient cooling system. This enables even higher continuous forces and due to forced cooling, no additional process heat is introduced during machine construction. The linear motors in the LMFA series achieve extremely high thrust and acceleration. In addition, an extremely high synchronism is achieved through the optimised configuration of the permanent magnets in the stator. The benefits of the LMFA linear motors make them the preferred choice in fields with very high loads as well as in applications in which no additional process heat must be introduced.



Key features of the LMFA linear motors:

- Efficient cooling system
- Extremely high thrust
- High acceleration
- UL-certified
- High synchronous run
- Full epoxy encapsulation of permanent magnets in the stator
- Optional: version with Hall sensor

Typical fields of application of the LMFA linear motors:

- Machine tools
- Portal milling machines
- Sheet metal forming machines

4.2 Order code LMFA linear motors

4.2.1 Order code of primary part (forcer)

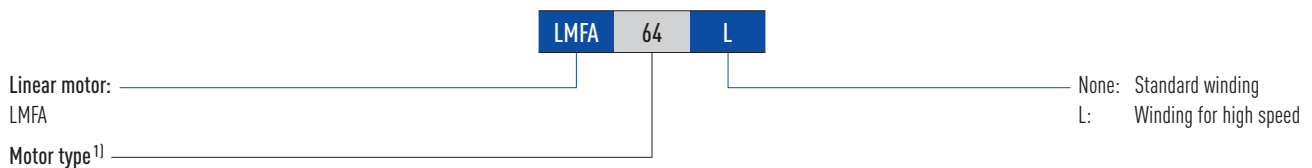

¹⁾ See Table 4.1 (LMFA0), Table 4.2 (LMFA1), Table 4.3 (LMFA2), Table 4.4 (LMFA3), Table 4.5 (LMFA4), Table 4.6 (LMFA5), Table 4.7 (LMFA6)

4.2.2 Order code of magnet track (stator)

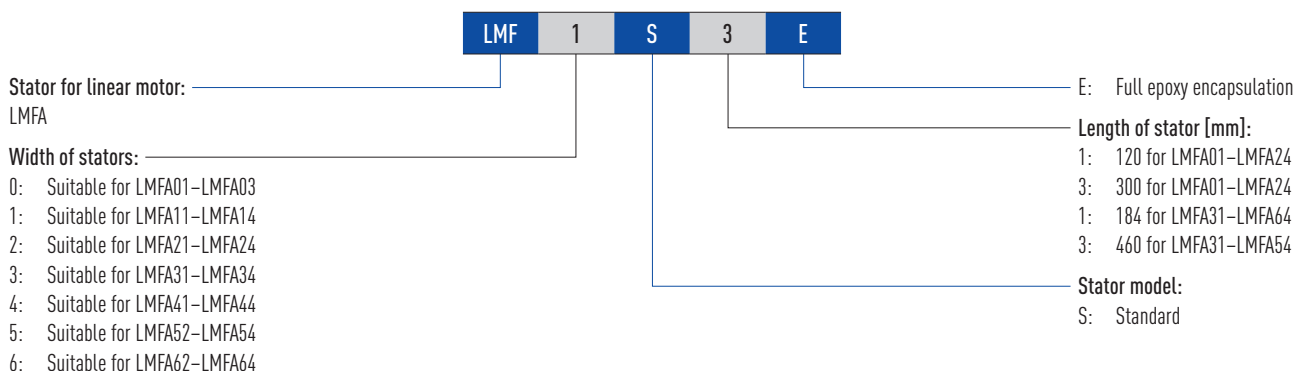

Linear Motors & Distance Measuring Systems

HIWIN LMFA linear motors

4.3 Force chart for LMFA linear motors

Force chart for linear motors LMFA0, LMFA1, LMFA2, LMFA3, LMFA4

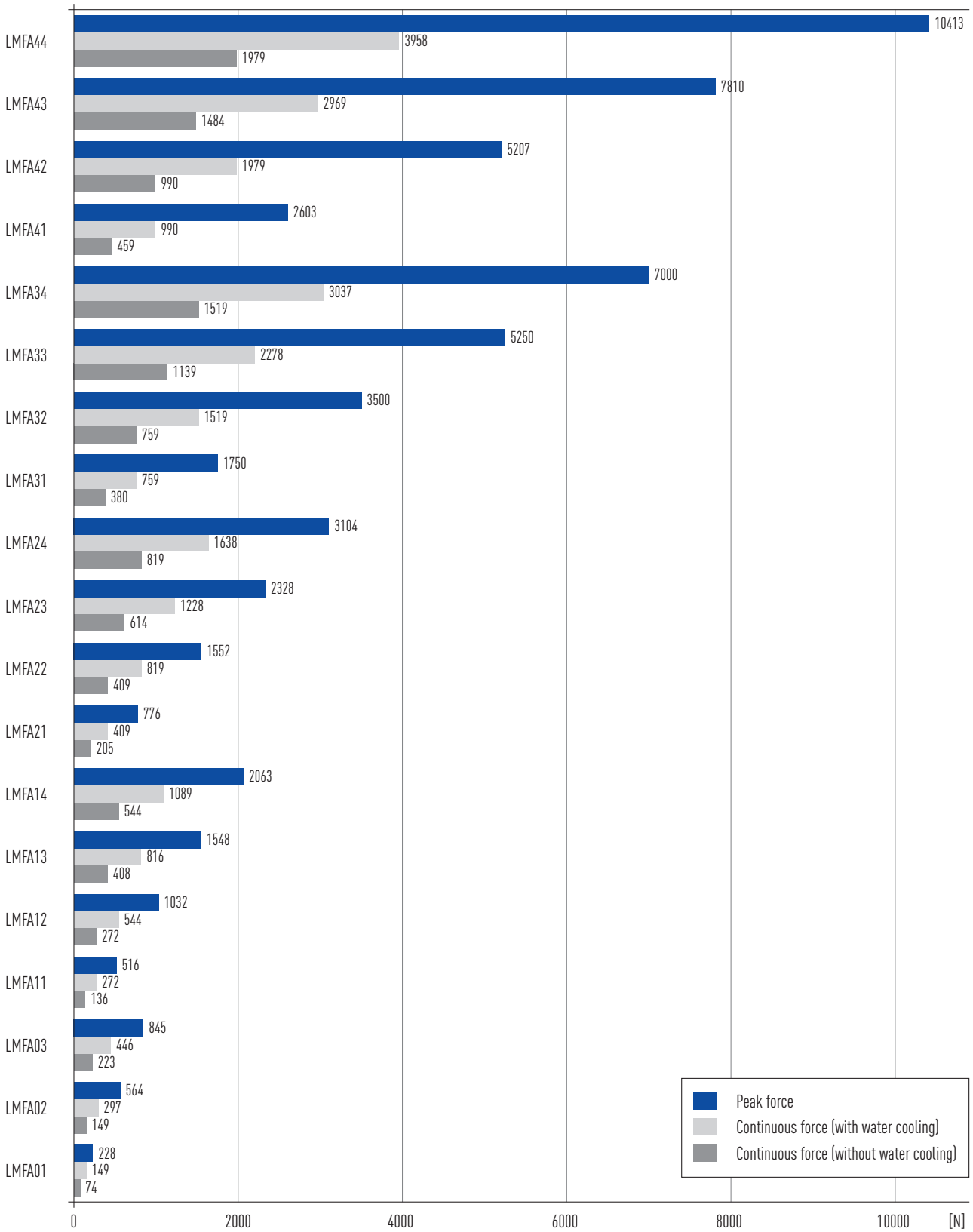

Force chart for linear motors LMFA5, LMFA6

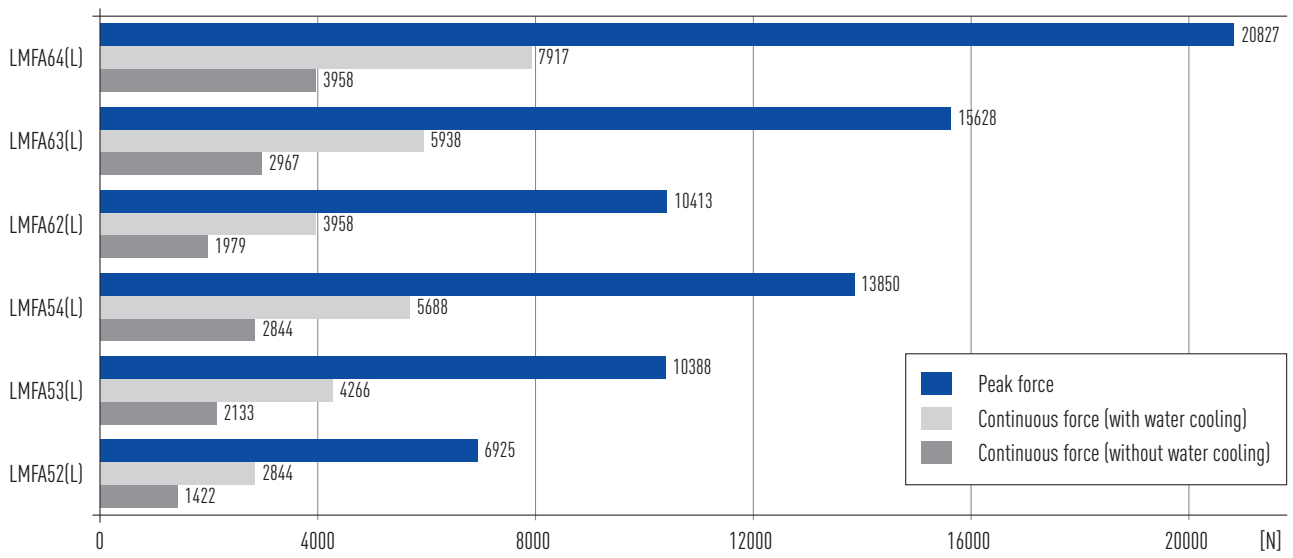

Linear Motors & Distance Measuring Systems

HIWIN LMFA linear motors

4.4 LMFA linear motor specifications

4.4.1 LMFA0 linear motor specifications

Force-velocity curves (DC bus voltage: 750 VDC)

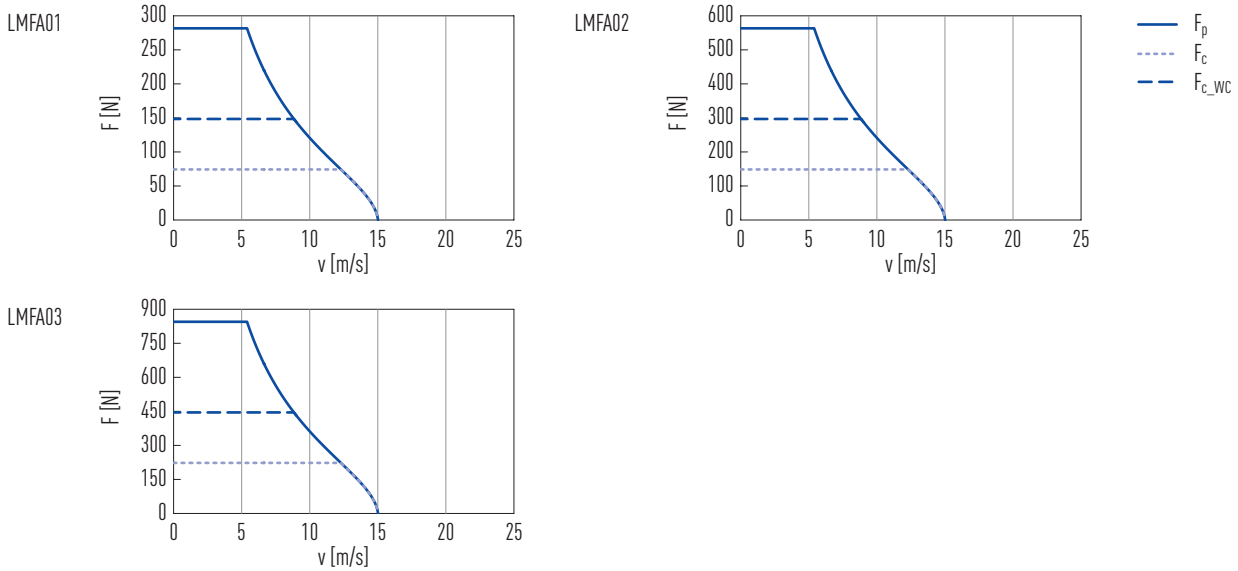

Table 4.1 Technical data for LMFA0

	Symbol	Unit	LMFA01	LMFA02	LMFA03
Forces and electrical parameters					
Continuous force at T_{max}	F_c	N	74	149	223
Peak force at T_{max} (WC)	F_{c_WC}	N	149	297	446
Continuous current at T_{max}	I_c	A_{eff}	1.4	2.7	4.1
Continuous current at T_{max} (WC)	I_{c_WC}	A_{eff}	2.7	5.4	8.1
Peak force (for 1 s)	F_p	N	282	564	845
Peak current (for 1 s)	I_p	A_{eff}	8.4	16.7	25.1
Force constant	K_f	N/A_{eff}	55.1	55.1	55.1
Attraction force	F_a	N	457	914	1,372
Electrical time constant	K_e	ms	7.2	7.2	7.2
Resistance ¹⁾	R_{25}	Ω	11.7	5.9	3.9
Inductance ¹⁾	L	mH	84.2	42.1	28.1
Back EMF constant	K_u	$V_{eff}/(m/s)$	31.8	31.8	31.8
Motor constant	K_m	N/\sqrt{W}	13.1	18.6	22.8
Thermal resistance	R_{th}	$^{\circ}C/W$	2.25	1.13	0.75
Thermal resistance (WC)	R_{th_WC}	$^{\circ}C/W$	0.56	0.28	0.19
Thermal switch			1 × PT1000 + 1 × (3 PTC SNM 120 in series)		
Max. DC bus voltage		V	750		
Mechanical parameters					
Pole pair pitch	2τ	mm	30		
Max. winding temperature	T_{max}	$^{\circ}C$	120		
Mounting holes (forcer)	n		2	4	6
Weight of forcer	M_F	kg	1.5	2.3	3.1
Length of forcer	L_F	mm	145	250	355
Unit mass of stator	M_S	kg/m	3.7		
Stator length/mounting holes	L_S	mm	120 mm/N = 2; 300 mm/N = 5		

WC: with water cooling

All specifications are in $\pm 10\%$ of tolerance at 25 $^{\circ}C$ ambient temperature

¹⁾ Line to line

Dimensions offorcer

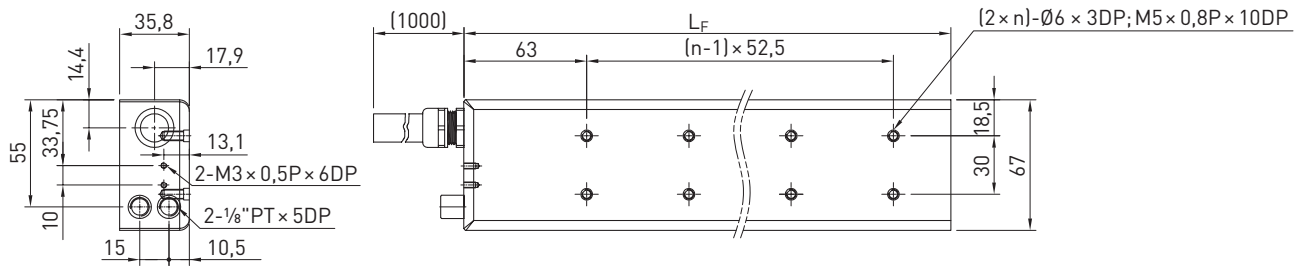

Dimensions of stator

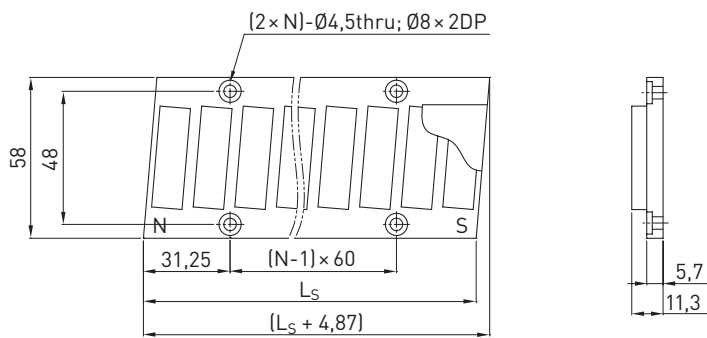

Mounting tolerances

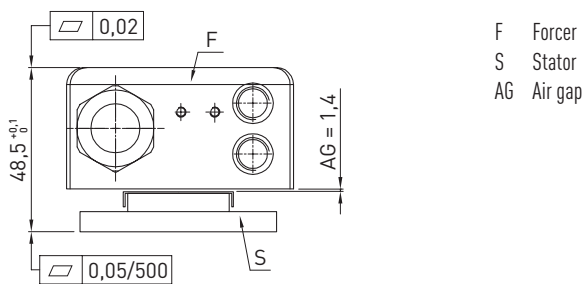

Stator versions available



Epoxy: Full epoxy encapsulation of permanent magnets

Stainless steel cover plate (upon request):
Additional stainless steel cover plate for magnet tracks

Linear Motors & Distance Measuring Systems

HIWIN LMFA linear motors

4.4.2 LMFA1 linear motor specifications

Force-velocity curves (DC bus voltage: 750 VDC)

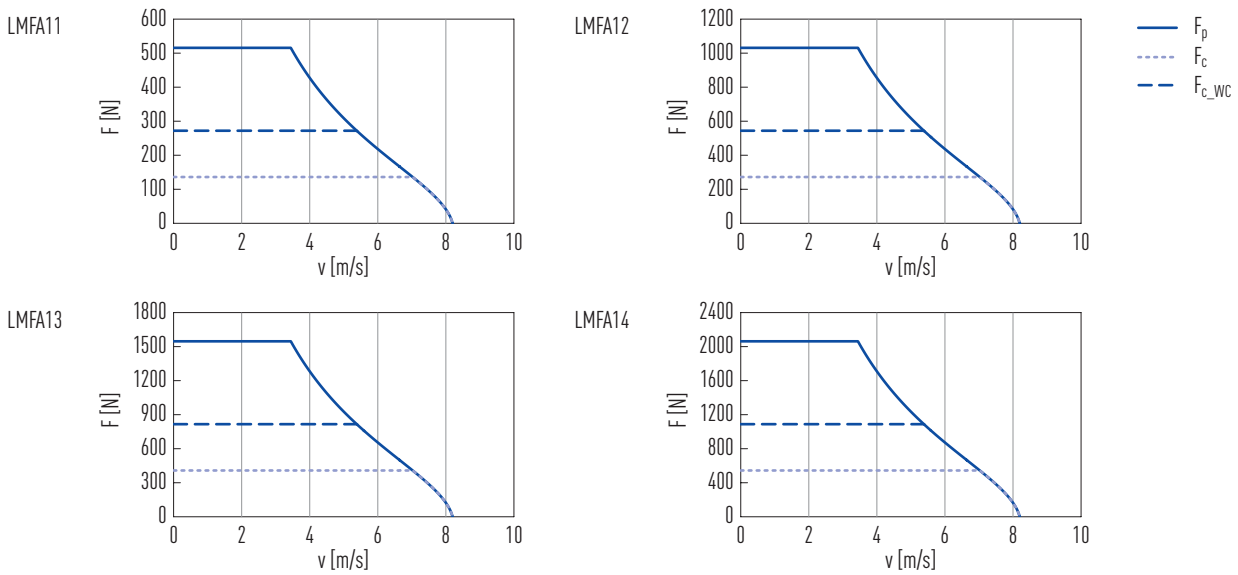

Table 4.2 Technical data for LMFA1

	Symbol	Unit	LMFA11	LMFA12	LMFA13	LMFA14
Forces and electrical parameters						
Continuous force at T_{max}	F_c	N	136	272	408	544
Continuous force at T_{max} (WC)	F_{c_WC}	N	272	544	816	1,089
Continuous current at T_{max}	I_c	A_{eff}	1.4	2.7	4.0	5.4
Continuous current at T_{max} (WC)	I_{c_WC}	A_{eff}	2.7	5.4	8.1	10.8
Peak force (for 1 s)	F_p	N	516	1,032	1,548	2,063
Peak current (for 1 s)	I_p	A_{eff}	8.4	16.7	25.1	33.5
Force constant	K_f	N/A_{eff}	100.8	100.8	100.8	100.8
Attraction force	F_a	N	837	1,674	2,511	3,348
Electrical time constant	K_e	ms	7.2	7.2	7.2	7.2
Resistance ¹⁾	R_{25}	Ω	16.9	8.4	5.6	4.2
Inductance ¹⁾	L	mH	121.9	60.9	40.6	30.5
Back EMF constant	K_u	$V_{eff}/(m/s)$	58.2	58.2	58.2	58.2
Motor constant	K_m	N/\sqrt{W}	20.0	28.3	34.7	40.1
Thermal resistance	R_{th}	$^{\circ}C/W$	1.56	0.78	0.52	0.39
Thermal resistance (WC)	R_{th_WC}	$^{\circ}C/W$	0.39	0.20	0.13	0.10
Thermal switch			1 \times PT1000 + 1 \times (3 PTC SNM 120 in series)			
Max. DC bus voltage		V	750			
Mechanical parameters						
Pole pair pitch	2τ	mm	30			
Max. winding temperature	T_{max}	$^{\circ}C$	120			
Mounting holes (forcer)	n		2	4	6	8
Weight of forcer	M_F	kg	2.4	4.0	5.6	7.6
Length of forcer	L_F	mm	145	250	355	460
Unit mass of stator	M_S	kg/m	5.8			
Stator length/mounting holes	L_S	mm	120 mm/N = 2; 300 mm/N = 5			

WC: with water cooling

All specifications are in $\pm 10\%$ of tolerance at 25 $^{\circ}C$ ambient temperature

¹⁾ Line to line

Dimensions of forcer

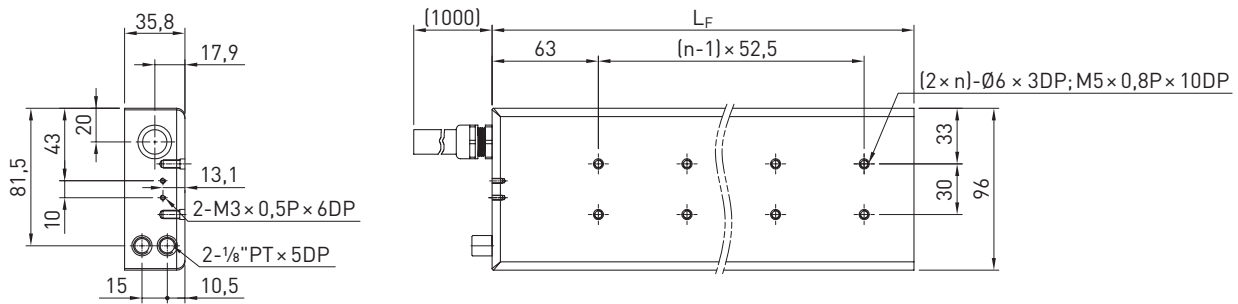

Dimensions of stator

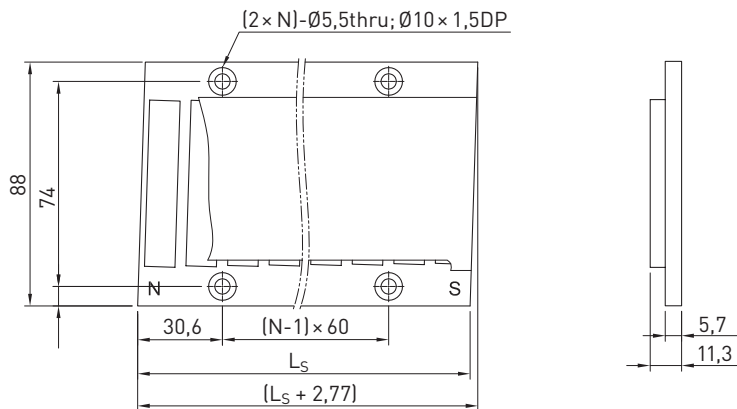

Mounting tolerances

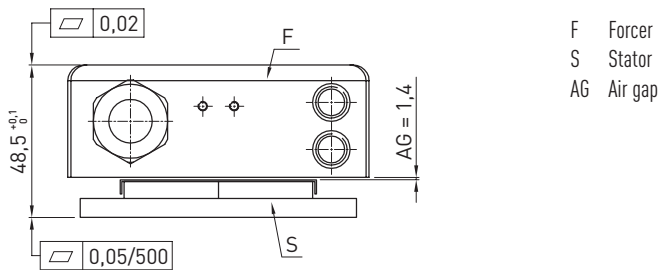

Stator versions available



Epoxy: Full epoxy encapsulation of permanent magnets

Stainless steel cover plate (upon request):
Additional stainless steel cover plate for magnet tracks

Linear Motors & Distance Measuring Systems

HIWIN LMFA linear motors

4.4.3 LMFA2 linear motor specifications

Force-velocity curves (DC bus voltage: 750 VDC)

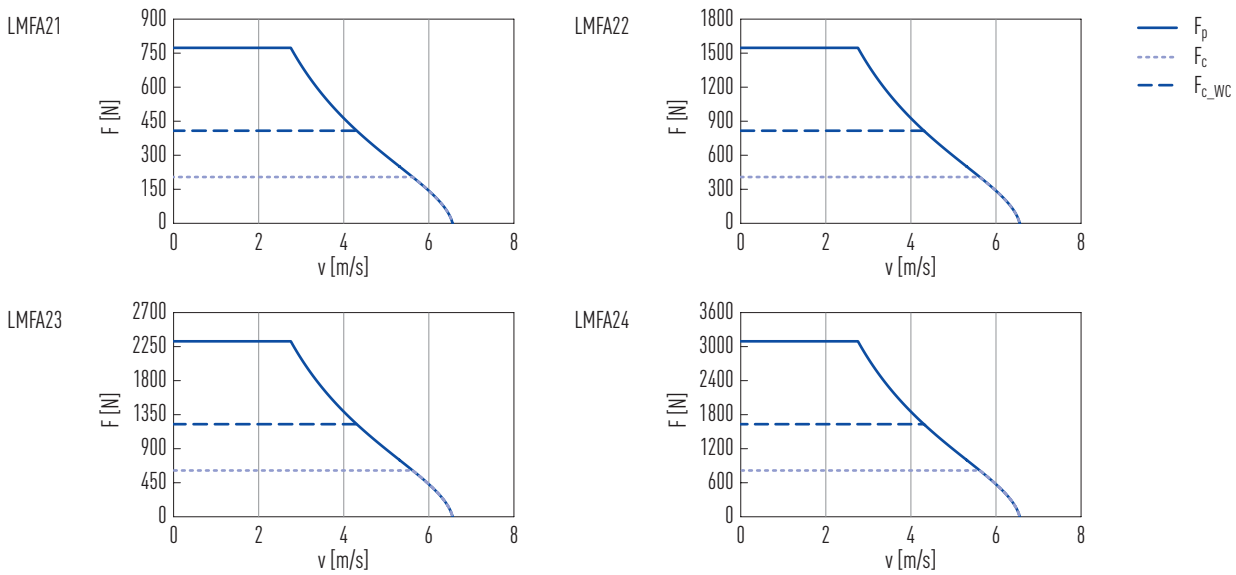

Table 4.3 Technical data for LMFA2

	Symbol	Unit	LMFA21	LMFA22	LMFA23	LMFA24
Forces and electrical parameters						
Continuous force at T_{max}	F_c	N	205	409	614	819
Continuous force at T_{max} (WC)	F_{c_WC}	N	409	819	1,228	1,638
Continuous current at T_{max}	I_c	A_{eff}	1.4	2.7	4.1	5.4
Continuous current at T_{max} (WC)	I_{c_WC}	A_{eff}	2.7	5.4	8.1	10.8
Peak force (for 1 s)	F_p	N	776	1,552	2,328	3,104
Peak current (for 1 s)	I_p	A_{eff}	8.4	16.7	25.1	33.5
Force constant	K_f	N/A_{eff}	151.6	151.6	151.6	151.6
Attraction force	F_a	N	1,259	2,518	3,777	5,036
Electrical time constant	K_e	ms	7.2	7.2	7.2	7.2
Resistance ¹⁾	R_{25}	Ω	24.8	12.4	8.3	6.2
Inductance ¹⁾	L	mH	178.6	89.3	59.5	44.6
Back EMF constant	K_u	$V_{eff}/(m/s)$	87.5	87.5	87.5	87.5
Motor constant	K_m	N/\sqrt{W}	24.9	35.2	43.1	49.7
Thermal resistance	R_{th}	$^{\circ}C/W$	1.06	0.53	0.35	0.27
Thermal resistance (WC)	R_{th_WC}	$^{\circ}C/W$	0.27	0.13	0.09	0.07
Thermal switch			1 × PT1000 + 1 × (3 PTC SNM 120 in series)			
Max. DC bus voltage		V	750			
Mechanical parameters						
Pole pair pitch	2τ	mm	30			
Max. winding temperature	T_{max}	$^{\circ}C$	120			
Mounting holes (forcer)	n		2	4	6	8
Weight of forcer	M_F	kg	3.2	5.5	8.0	10.4
Length of forcer	L_F	mm	145	250	355	460
Unit mass of stator	M_S	kg/m	9.8			
Stator length/mounting holes	L_S	mm	120 mm/N = 2; 300 mm/N = 5			

WC: with water cooling

All specifications are in $\pm 10\%$ of tolerance at 25 $^{\circ}C$ ambient temperature

¹⁾ Line to line

Dimensions of forcer

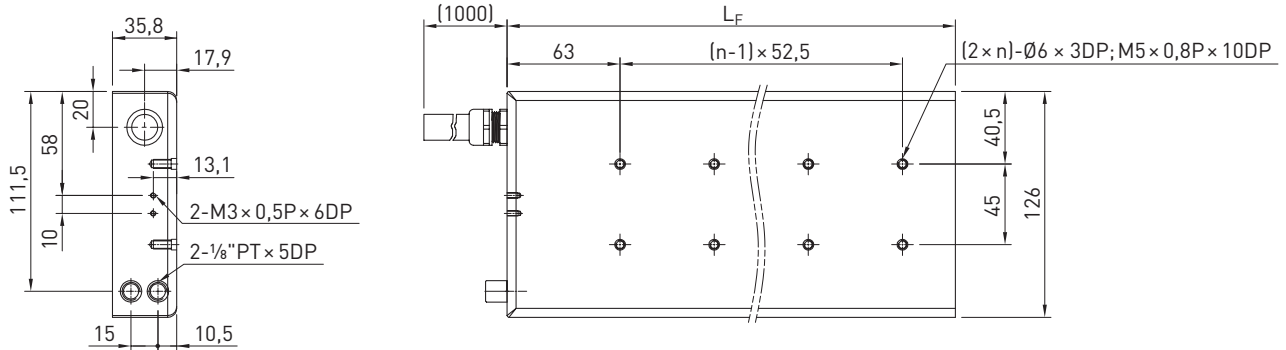

Dimensions of stator

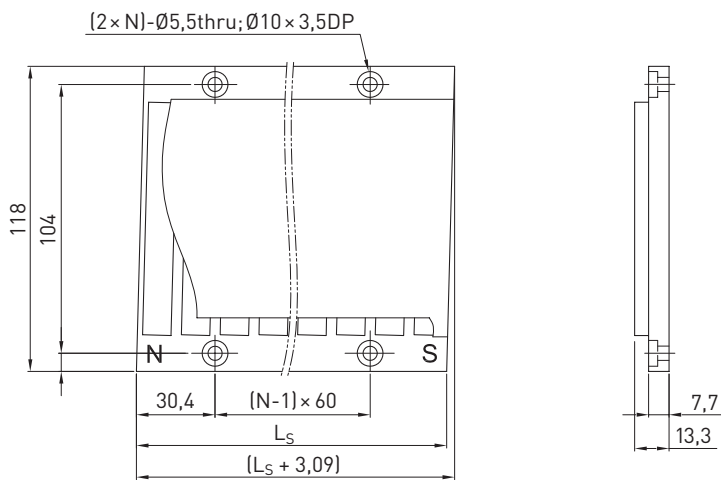

Mounting tolerances

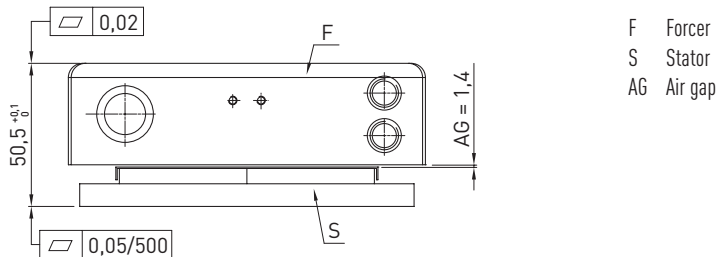

Stator versions available



Epoxy: Full epoxy encapsulation of permanent magnets

Stainless steel cover plate (upon request): Additional stainless steel cover plate for magnet tracks

Linear Motors & Distance Measuring Systems

HIWIN LMFA linear motors

4.4.4 LMFA3 linear motor specifications

Force-velocity curves (DC bus voltage: 750 VDC)

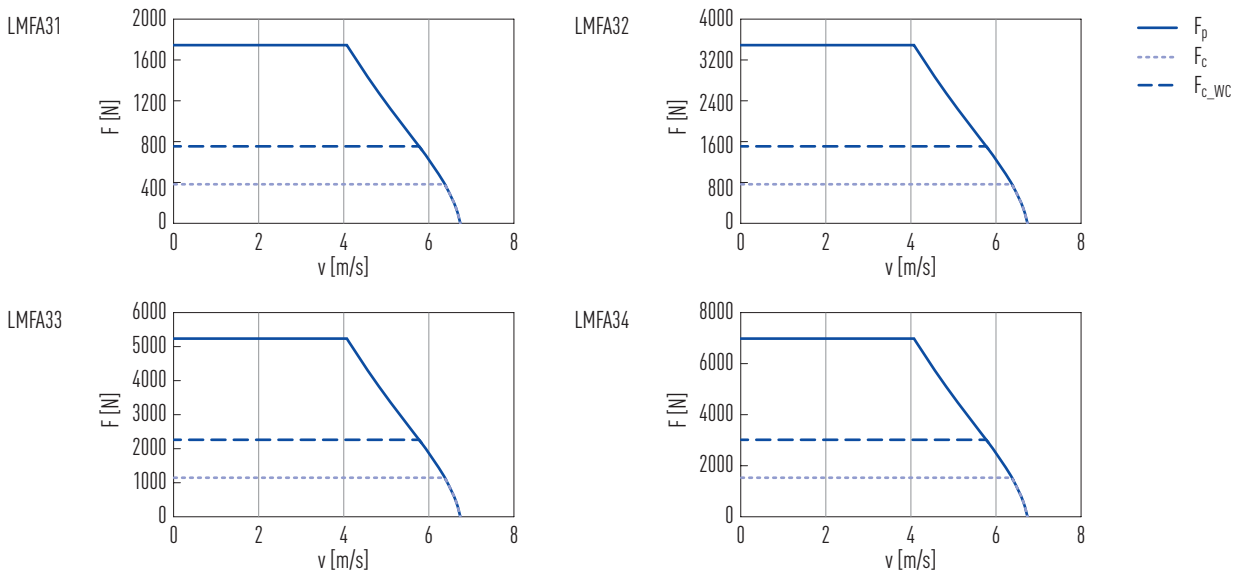

Table 4.4 Technical data for LMFA3

	Symbol	Unit	LMFA31	LMFA32	LMFA33	LMFA34
Forces and electrical parameters						
Continuous force at T_{max}	F_c	N	380	759	1,139	1,519
Continuous force at T_{max} (WC)	F_{c_WC}	N	759	1,519	2,278	3,037
Continuous current at T_{max}	I_c	A_{eff}	3.1	6.2	9.3	12.4
Continuous current at T_{max} (WC)	I_{c_WC}	A_{eff}	6.2	12.4	18.6	24.7
Peak force (for 1 s)	F_p	N	1,750	3,500	5,250	7,000
Peak current (for 1 s)	I_p	A_{eff}	19.2	38.4	57.5	76.7
Force constant	K_f	N/A_{eff}	122.7	122.7	122.7	122.7
Attraction force	F_a	N	3,430	6,860	10,290	13,720
Electrical time constant	K_e	ms	11.3	11.3	11.3	11.3
Resistance ¹⁾	R_{25}	Ω	4.3	2.1	1.4	1.1
Inductance ¹⁾	L	mH	48.3	24.2	16.1	12.1
Back EMF constant	K_u	$V_{eff}/(m/s)$	70.9	70.9	70.9	70.9
Motor constant	K_m	N/\sqrt{W}	48.4	68.5	83.9	96.9
Thermal resistance	R_{th}	$^{\circ}C/W$	1.17	0.59	0.39	0.29
Thermal resistance (WC)	R_{th_WC}	$^{\circ}C/W$	0.29	0.15	0.10	0.07
Thermal switch			1 × PT1000 + 1 × (3 PTC SNM 120 in series)			
Max. DC bus voltage		V	750			
Mechanical parameters						
Pole pair pitch	2τ	mm	46			
Max. winding temperature	T_{max}	$^{\circ}C$	120			
Mounting holes (forcer)	n		2	4	6	8
Weight of forcer	M_F	kg	6.4	11.7	17.3	22.5
Length of forcer	L_F	mm	214	375	536	697
Unit mass of stator	M_S	kg/m	16.2			
Stator length/mounting holes	L_S	mm	184 mm/N = 2; 460 mm/N = 5			

WC: with water cooling

All specifications are in $\pm 10\%$ of tolerance at 25 $^{\circ}C$ ambient temperature

¹⁾ Line to line

Dimensions offorcer

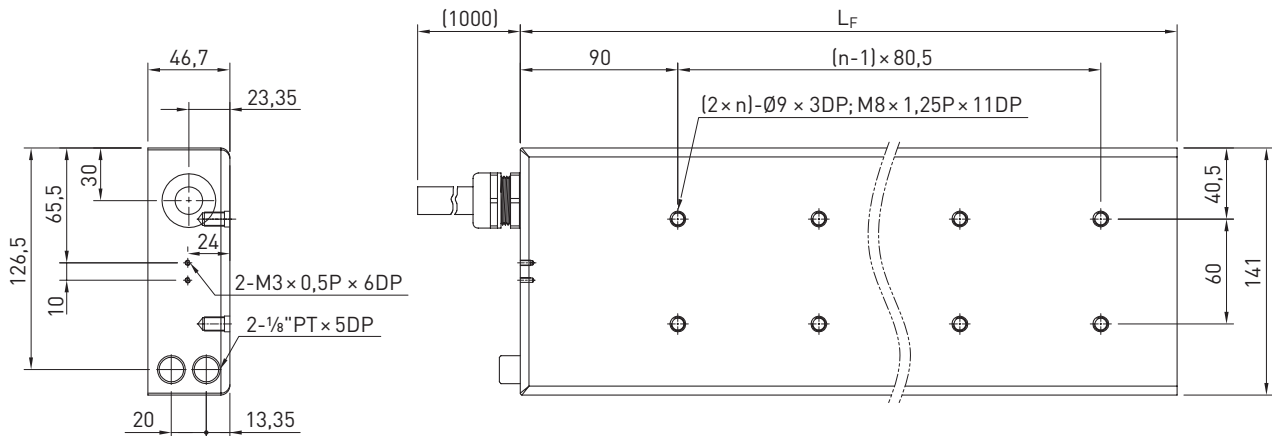

Dimensions of stator

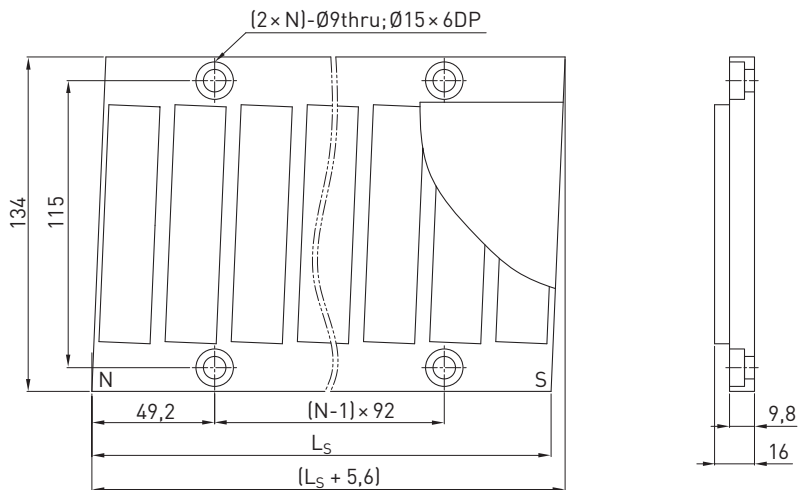

Mounting tolerances

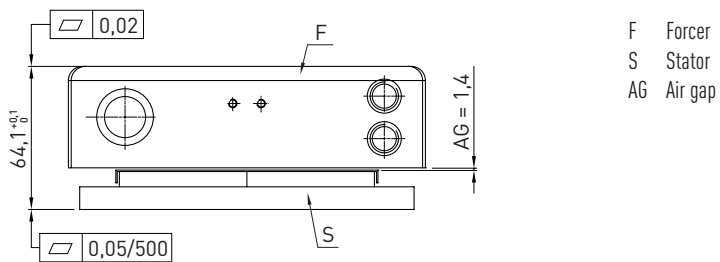

Stator versions available



Epoxy: Full epoxy encapsulation of permanent magnets

Stainless steel cover plate (upon request): Additional stainless steel cover plate for magnet tracks

Linear Motors & Distance Measuring Systems

HIWIN LMFA linear motors

4.4.5 LMFA4 linear motor specifications

Force-velocity curves (DC bus voltage: 750 VDC)

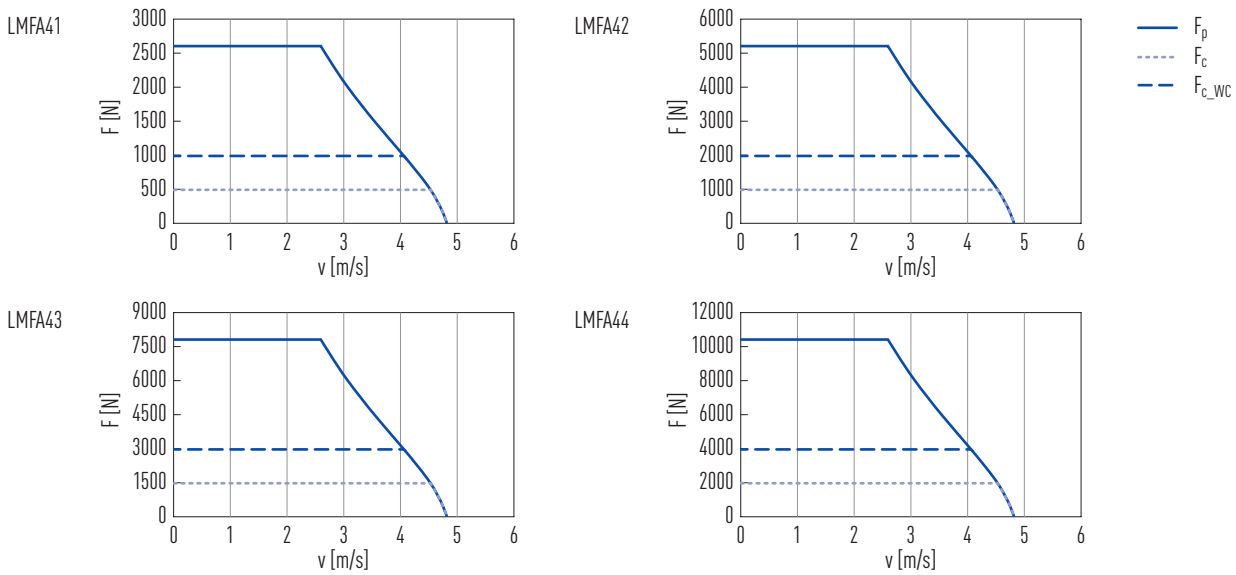

Table 4.5 Technical data for LMFA4

	Symbol	Unit	LMFA41	LMFA42	LMFA43	LMFA44
Forces and electrical parameters						
Continuous force at T_{max}	F_c	N	495	990	1,484	1,979
Continuous force at T_{max} (WC)	F_{c_WC}	N	990	1,979	2,969	3,958
Continuous current at T_{max}	I_c	A_{eff}	2.9	5.8	8.7	11.5
Continuous current at T_{max} (WC)	I_{c_WC}	A_{eff}	5.8	11.5	17.3	23.1
Peak force (for 1 s)	F_p	N	2,603	5,207	7,810	10,413
Peak current (for 1 s)	I_p	A_{eff}	17.9	35.8	53.5	71.6
Force constant	K_f	N/A_{eff}	171.4	171.4	171.4	171.4
Attraction force	F_a	N	5,145	10,290	15,435	20,580
Electrical time constant	K_e	ms	12.0	12.0	12.0	12.0
Resistance ¹⁾	R_{25}	Ω	6.0	3.0	2.0	1.5
Inductance ¹⁾	L	mH	72.0	36.0	24.0	18.0
Back EMF constant	K_u	$V_{eff}/(m/s)$	98.9	98.9	98.9	98.9
Motor constant	K_m	N/\sqrt{W}	57.1	80.8	98.9	114.2
Thermal resistance	R_{th}	$^{\circ}C/W$	0.96	0.48	0.32	0.24
Thermal resistance (WC)	R_{th_WC}	$^{\circ}C/W$	0.24	0.12	0.08	0.06
Thermal switch			1 × PT1000 + 1 × (3 PTC SNM 120 in series)			
Max. DC bus voltage		V	750			
Mechanical parameters						
Pole pair pitch	2τ	mm	46			
Max. winding temperature	T_{max}	$^{\circ}C$	120			
Mounting holes (forcer)	n		2	4	6	8
Weight of forcer	M_F	kg	9.5	16.2	23.0	29.0
Length of forcer	L_F	mm	214	375	536	697
Unit mass of stator	M_S	kg/m	22.3			
Stator length/mounting holes	L_S	mm	184 mm/N = 2; 460 mm/N = 5			

WC: with water cooling

All specifications are in $\pm 10\%$ of tolerance at 25 $^{\circ}C$ ambient temperature

¹⁾ Line to line

Dimensions of forcer

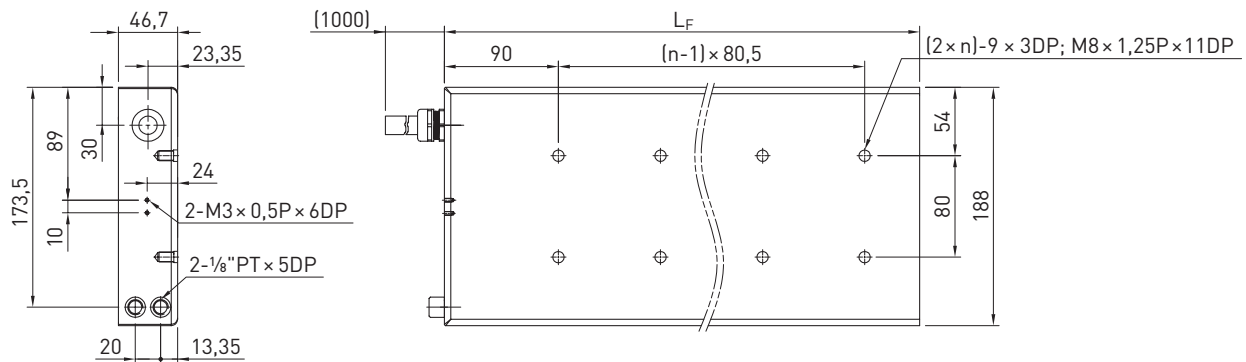

Dimensions of stator

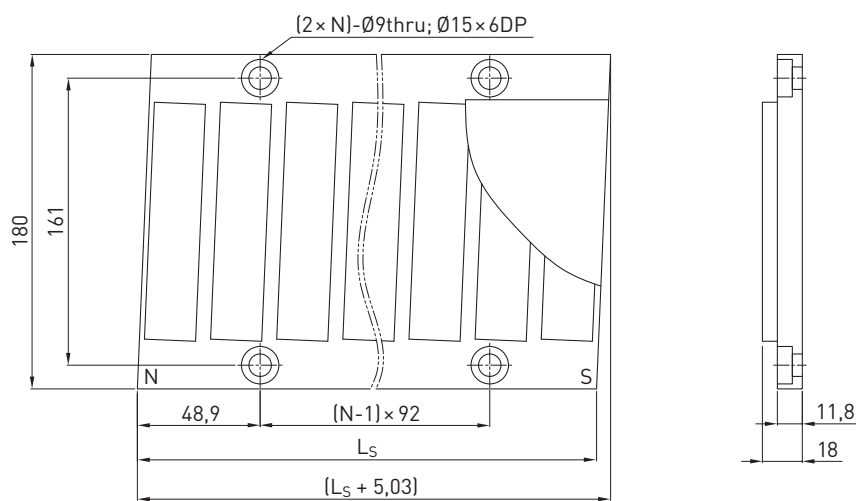

Mounting tolerances

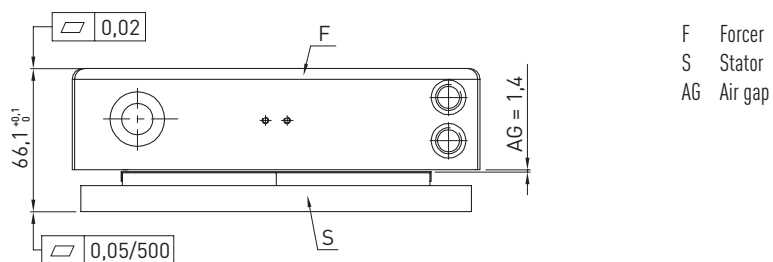

Stator versions available



Epoxy: Full epoxy encapsulation of permanent magnets

Stainless steel cover plate (upon request): Additional stainless steel cover plate for magnet tracks

Linear Motors & Distance Measuring Systems

HIWIN LMFA linear motors

4.4.6 LMFA5 linear motor specifications

Force-velocity curves (DC bus voltage: 750 VDC)

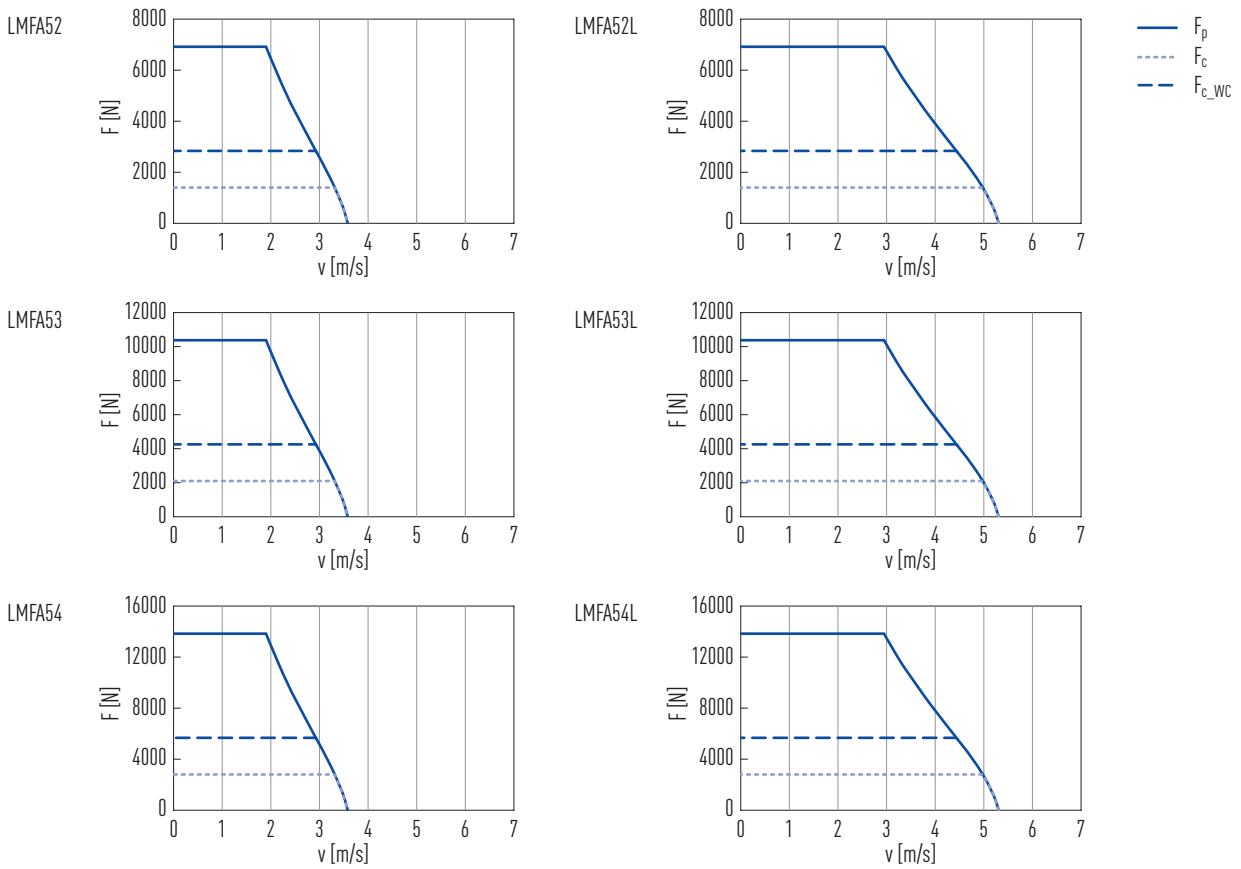

Table 4.6 Technical data for LMFA5

	Symbol	Unit	LMFA52	LMFA52L	LMFA53	LMFA53L	LMFA54	LMFA54L
Forces and electrical parameters								
Continuous force at T_{max}	F_c	N	1,422		2,133		2,844	
Continuous force at T_{max} (WC)	F_{c_WC}	N	2,844		4,266		5,688	
Continuous current at T_{max}	I_c	A_{eff}	6.2	9.1	9.3	13.7	12.4	18.3
Continuous current at T_{max} (WC)	I_{c_WC}	A_{eff}	12.4	18.3	18.6	27.4	24.7	36.5
Peak force (for 1 s)	F_p	N	6,925		10,388		13,850	
Peak current (for 1 s)	I_p	A_{eff}	38.4	56.6	57.5	84.9	76.7	113.2
Force constant	K_f	N/A_{eff}	229.9	155.7	229.9	155.7	229.9	155.7
Attraction force	F_a	N	13,700		20,550		27,400	
Electrical time constant	K_e	ms	12.2	12.4	12.2	12.4	12.2	12.4
Resistance ¹⁾	R_{25}	Ω	3.9	1.8	2.6	1.2	2.0	0.9
Inductance ¹⁾	L	mH	47.7	21.9	31.8	14.6	23.9	10.9
Back EMF constant	K_u	$V_{eff}/(m/s)$	132.7	89.9	132.7	89.9	132.7	89.9
Motor constant	K_m	N/\sqrt{W}	95.0	95.6	116.4	117.1	134.4	135.2
Thermal resistance	R_{th}	$^{\circ}C/W$	0.32	0.33	0.21	0.22	0.16	0.16
Thermal resistance (WC)	R_{th_WC}	$^{\circ}C/W$	0.08	0.08	0.05	0.05	0.04	0.04
Thermal switch			1 × PT1000 + 1 × (3 PTC SNM 120 in series)					
Max. DC bus voltage		V	750					
Mechanical parameters								
Pole pair pitch	2τ	mm	46					
Max. winding temperature	T_{max}	$^{\circ}C$	120					
Mounting holes (forcer)	n		4			6		8
Weight of forcer	M_F	kg	23.8		32.3		40.8	
Length of forcer	L_F	mm	375		536		697	
Unit mass of stator	M_S	kg/m	25					
Stator length/mounting holes	L_S	mm	184 mm/N = 2; 460 mm/N = 5					

WC: with water cooling

All specifications are in $\pm 10\%$ of tolerance at 25 $^{\circ}C$ ambient temperature

¹⁾ Line to line

Stator versions available

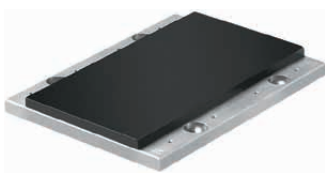

Epoxy: Full epoxy encapsulation of permanent magnets



Stainless steel cover plate (upon request):
Additional stainless steel cover plate for magnet tracks

Linear Motors & Distance Measuring Systems

HIWIN LMFA linear motors

Dimensions of forcer

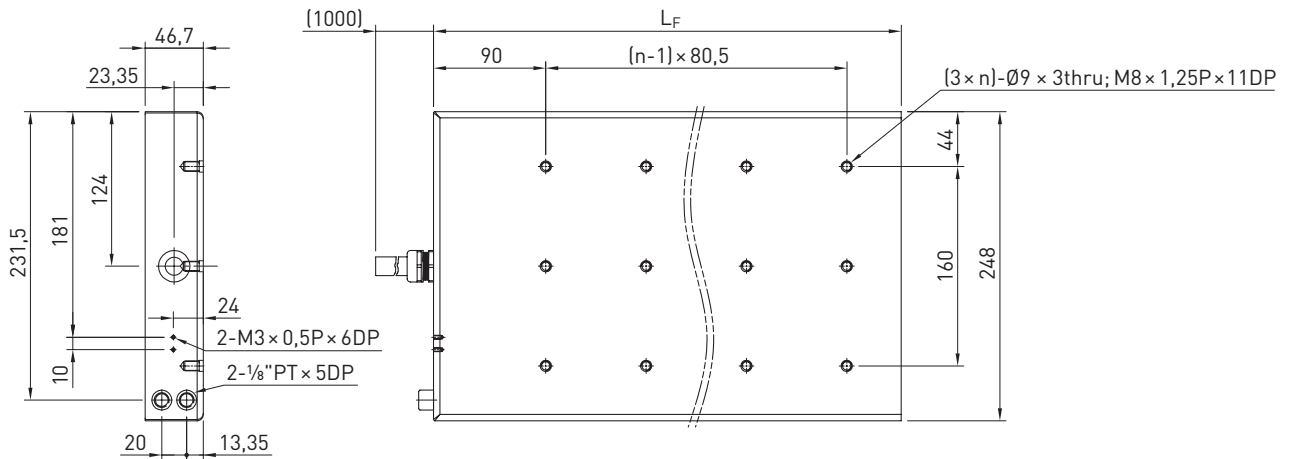

Dimensions of stator

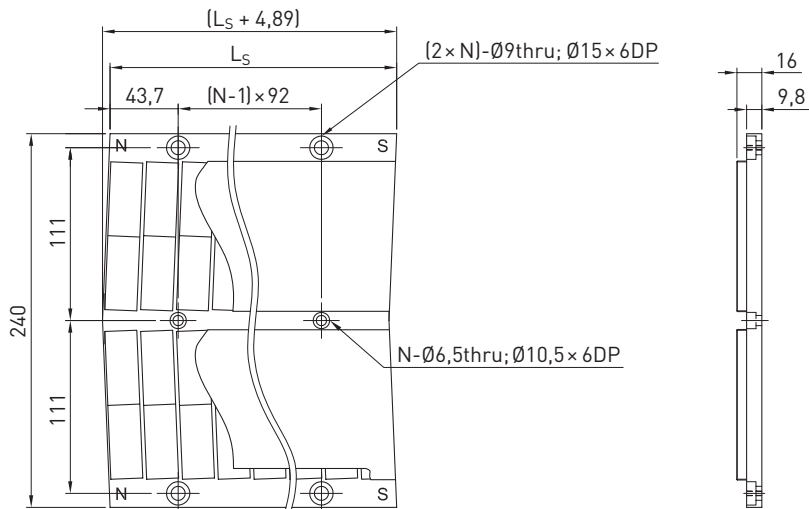

Mounting tolerances

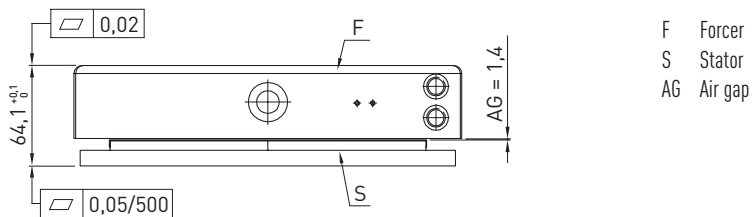

4.4.7 LMFA6 linear motor specifications

Force-velocity curves (DC bus voltage: 750 VDC)

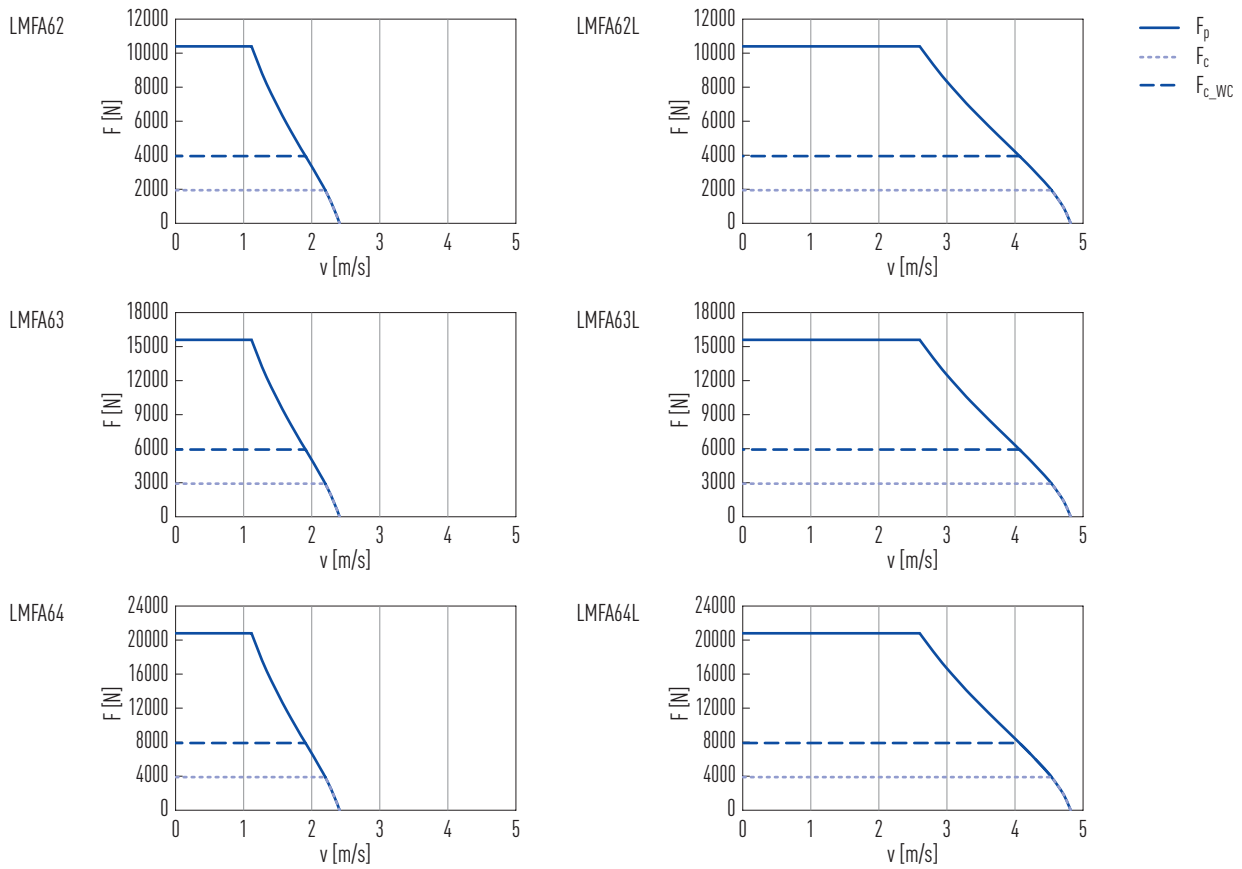

Linear Motors & Distance Measuring Systems

HIWIN LMFA linear motors

Table 4.7 Technical data for LMFA6

	Symbol	Unit	LMFA62	LMFA62L	LMFA63	LMFA63L	LMFA64	LMFA64L
Forces and electrical parameters								
Continuous force at T_{max}	F_c	N	1,979		2,969		3,958	
Continuous force at T_{max} (WC)	F_{c_WC}	N	3,958		5,938		7,917	
Continuous current at T_{max}	I_c	A_{eff}	5.8	11.5	8.7	17.3	11.5	23.1
Continuous current at T_{max} (WC)	I_{c_WC}	A_{eff}	11.5	23.1	17.3	34.6	23.1	46.2
Peak force (for 1 s)	F_p	N	10,413		15,620		20,827	
Peak current (for 1 s)	I_p	A_{eff}	35.8	71.6	53.7	107.4	71.3	142.6
Force constant	K_f	N/A_{eff}	342.7	171.4	342.7	171.4	342.7	171.4
Attraction force	F_a	N	20,580		30,870		41,160	
Electrical time constant	K_e	ms	12.0					
Resistance ¹⁾	R_{25}	Ω	6.0	1.5	4.0	1.0	3.0	0.8
Inductance ¹⁾	L	mH	72.0	18.0	48.0	12.0	36.0	9.0
Back EMF constant	K_u	$V_{eff}/(m/s)$	197.9	98.9	197.9	98.9	197.9	98.9
Motor constant	K_m	N/\sqrt{W}	114.2		139.9		161.6	
Thermal resistance	R_{th}	$^{\circ}C/W$	0.24		0.16		0.12	
Thermal resistance (WC)	R_{th_WC}	$^{\circ}C/W$	0.06		0.04		0.03	
Thermal switch			1 × PT1000 + 1 × (3 PTC SNM 120 in series)					
Max. DC bus voltage		V	750					
Mechanical parameters								
Pole pair pitch	2τ	mm	46					
Max. winding temperature	T_{max}	$^{\circ}C$	120					
Mounting holes (forcer)	n		4		6		8	
Weight of forcer	M_F	kg	32.2		44.2		56.2	
Length of forcer	L_F	mm	375		536		697	
Unit mass of stator	M_S	kg/m	40.1					
Stator length/mounting holes	L_S	mm	184 mm/N = 2					

WC: with water cooling

All specifications are in $\pm 10\%$ of tolerance at 25 $^{\circ}C$ ambient temperature

¹⁾ Line to line

Stator versions available

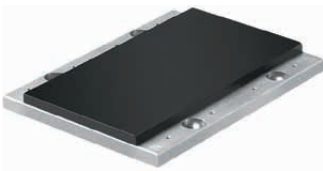

Epoxy: Full epoxy encapsulation of permanent magnets

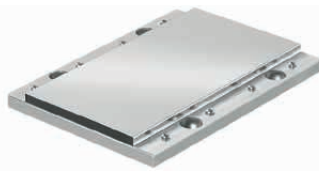

Stainless steel cover plate (upon request):
Additional stainless steel cover plate for magnet tracks

Dimensions of forcer

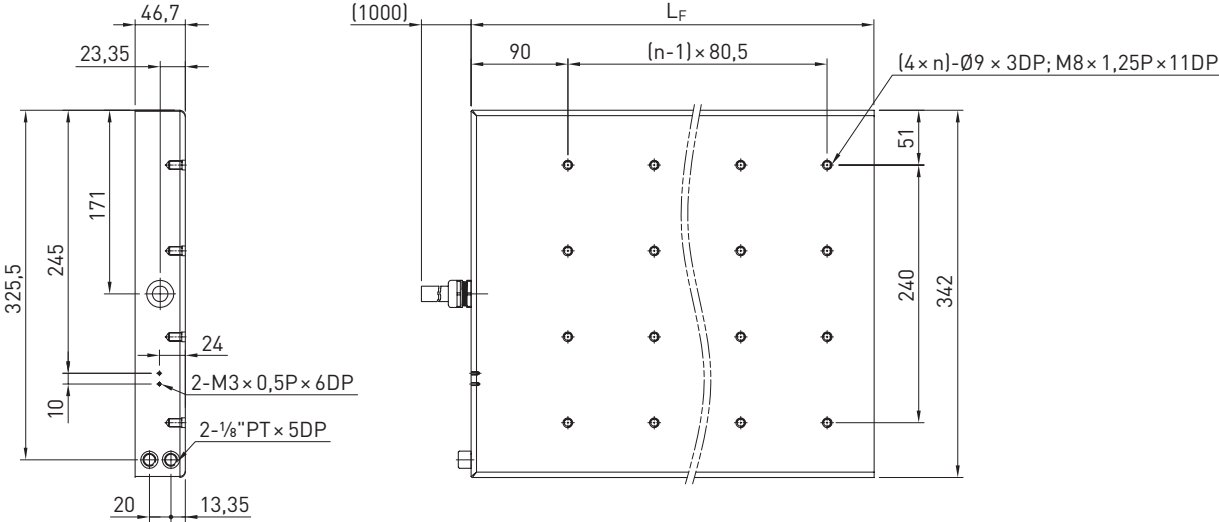

Dimensions of stator

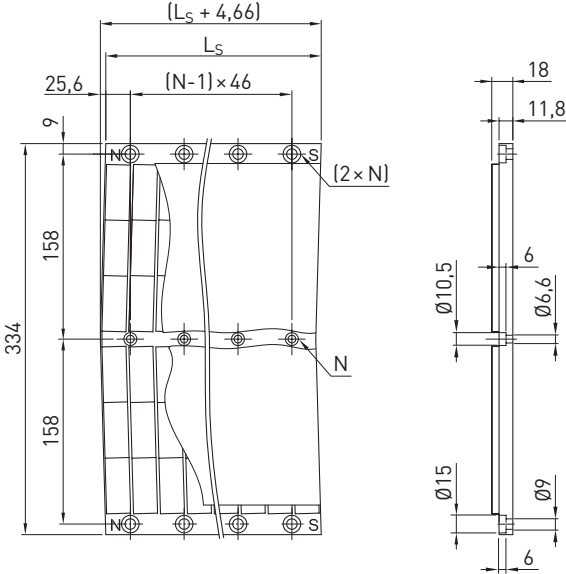

Mounting tolerances

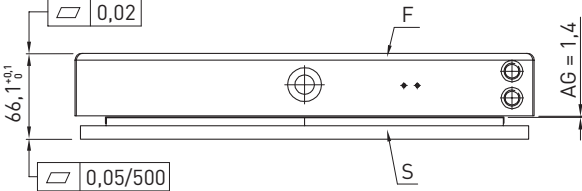

- F Forcer
- S Stator
- AG Air gap

Linear Motors & Distance Measuring Systems

HIWIN LMFP linear motors

5. HIWIN LMFP linear motors

5.1 Special characteristics of the LMFP linear motors

Like their cousins from the LMFA series, the enclosed HIWIN LMFP synchronous linear motors represent the cooled power packs among the linear drives. The decisive difference here is the fully encapsulated design in accordance with protection class IP65, thanks to which LMFP linear motors can also withstand difficult ambient conditions where others reach their limits. They achieve very high continuous forces, extremely high thrust forces and accelerations and, thanks to liquid cooling, do not introduce any additional process heat into your system.

LMFP linear motors are therefore the first choice for applications where very high loads encounter difficult ambient conditions with liquids or dust.



Key features of the LMFP linear motors:

- Sealed design: Protection class IP65
- Efficient cooling system
- Extremely high thrust
- High acceleration
- High synchronous run
- Full epoxy encapsulation of permanent magnets in the stator
- Optional: version with Hall sensor

Typical fields of application of the LMFP linear motors:

- Machine tools
- Portal milling machines
- Sheet metal forming machines

5.2 Order code LMFP linear motors

5.2.1 Order code of primary part (forcer)

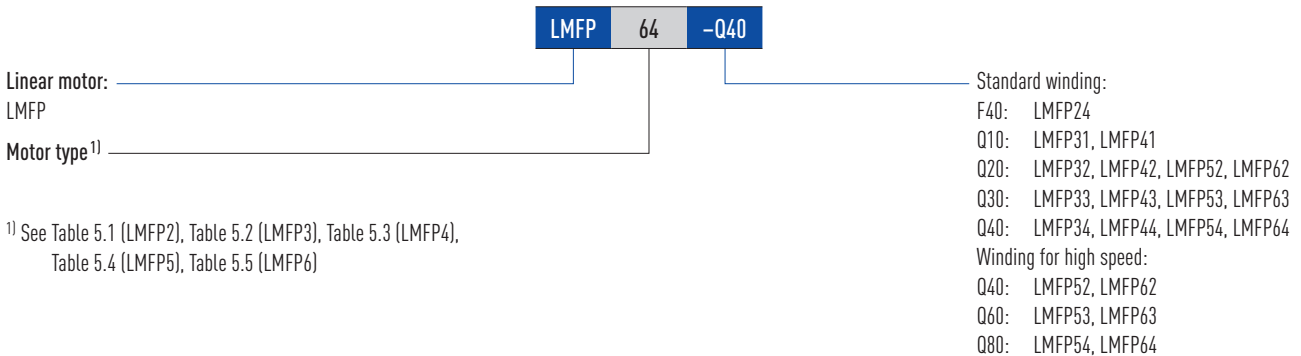

¹⁾ See Table 5.1 (LMFP2), Table 5.2 (LMFP3), Table 5.3 (LMFP4), Table 5.4 (LMFP5), Table 5.5 (LMFP6)

5.2.2 Order code of magnet track (stator)

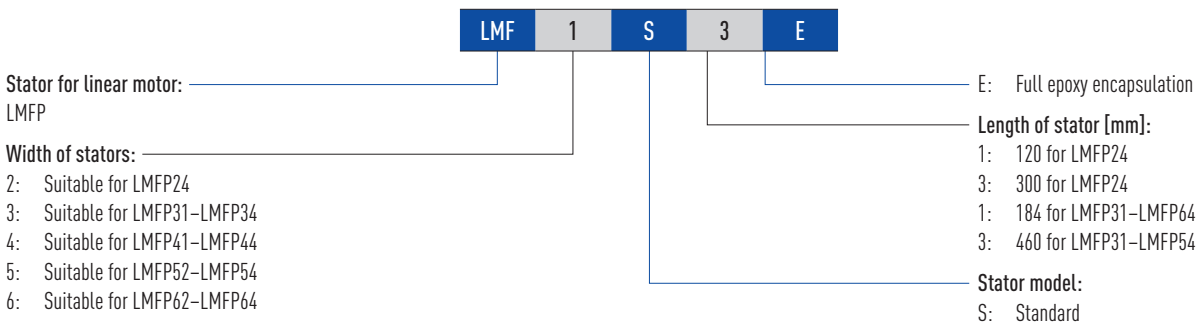

5.3 Force chart for LMFP linear motors

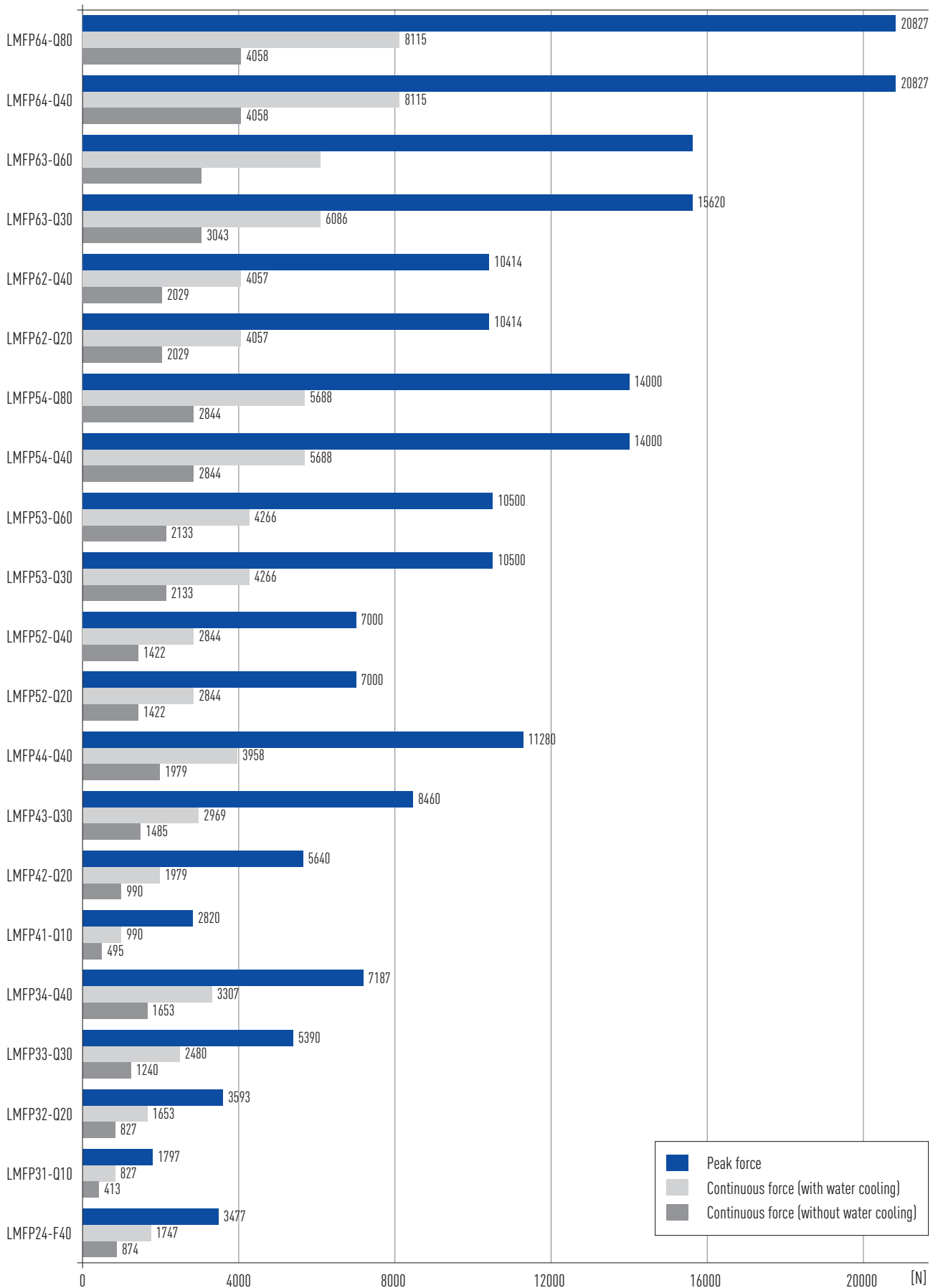

Linear Motors & Distance Measuring Systems

HIWIN LMFP linear motors

5.4 LMFP linear motor specifications

5.4.1 LMFP2 linear motor specifications

Force-velocity curves (DC bus voltage: 600 VDC)

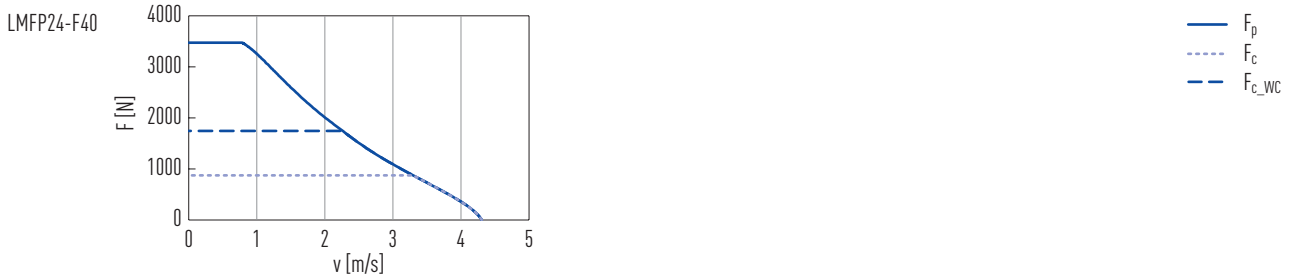

Table 5.1 Technical data for LMFP2

	Symbol	Unit	LMFP24-F40
Forces and electrical parameters			
Continuous force at T_{max}	F_c	N	874
Peak force at T_{max} (WC)	F_{c_WC}	N	1,747
Continuous current at T_{max}	I_c	A_{eff}	5.7
Continuous current at T_{max} (WC)	I_{c_WC}	A_{eff}	11.4
Peak force (for 1 s)	F_p	N	3,477
Peak current (for 1 s)	I_p	A_{eff}	32.8
Force constant	K_f	N/A_{eff}	153.6
Attraction force	F_a	N	4,583
Electrical time constant	K_e	ms	8.1
Resistance ¹⁾	R_{25}	Ω	7.1
Inductance ¹⁾	L	mH	57.6
Back EMF constant	K_v	$V_{eff}/(m/s)$	88.7
Motor constant	K_m	N/\sqrt{W}	47
Thermal resistance	R_{th}	$^{\circ}C/W$	0.2
Thermal resistance (WC)	R_{th_WC}	$^{\circ}C/W$	0.05
Thermal switch			1 × PT1000 + 1 × (3 PTC SNM 120 in series)
Max. DC bus voltage		V	750
Mechanical parameters			
Pole pair pitch	2τ	mm	30
Max. winding temperature	T_{max}	$^{\circ}C$	120
Mounting holes (forcer)	n		16
Weight of forcer	M_F	kg	11
Length of forcer	L_F	mm	465
Unit mass of stator	M_S	kg/m	9.8
Stator length/mounting holes	L_S	mm	120 mm/N = 2; 300 mm/N = 5
Total height	H	mm	50.5

WC: with water cooling

All specifications are in $\pm 10\%$ of tolerance at 25 $^{\circ}C$ ambient temperature

¹⁾ Line to line

Dimensions of forcer

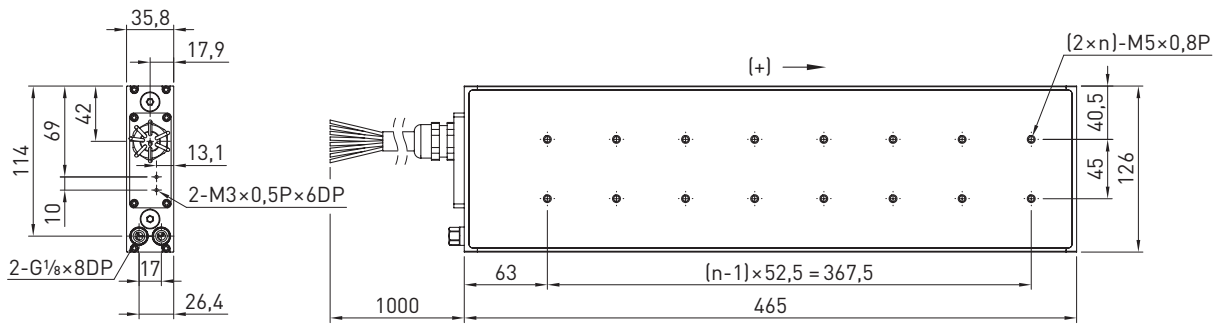

Dimensions of stator

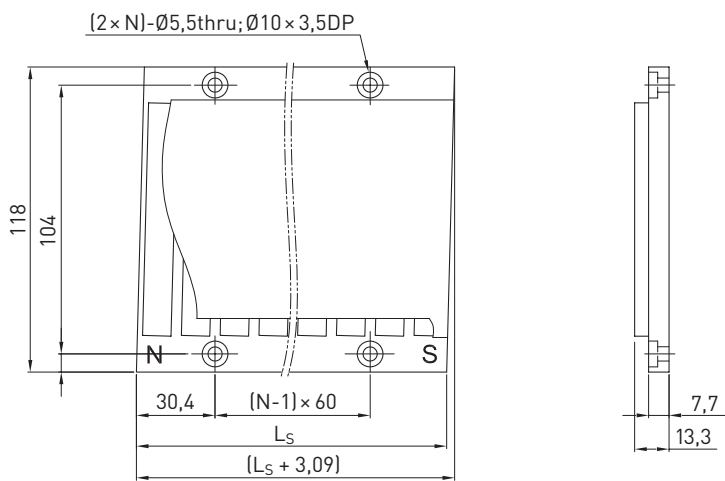

Mounting tolerances

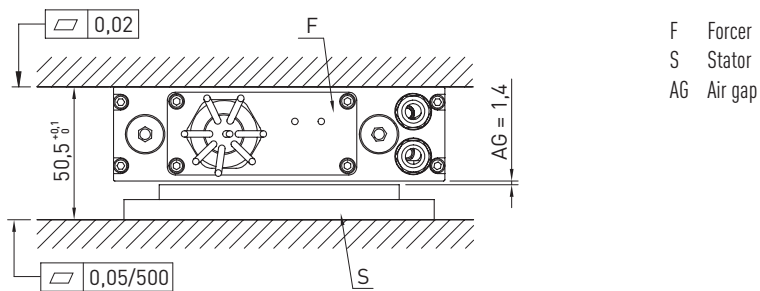

Linear Motors & Distance Measuring Systems

HIWIN LMFP linear motors

5.4.2 LMFP3 linear motor specifications

Force-velocity curves (DC bus voltage: 600 VDC)

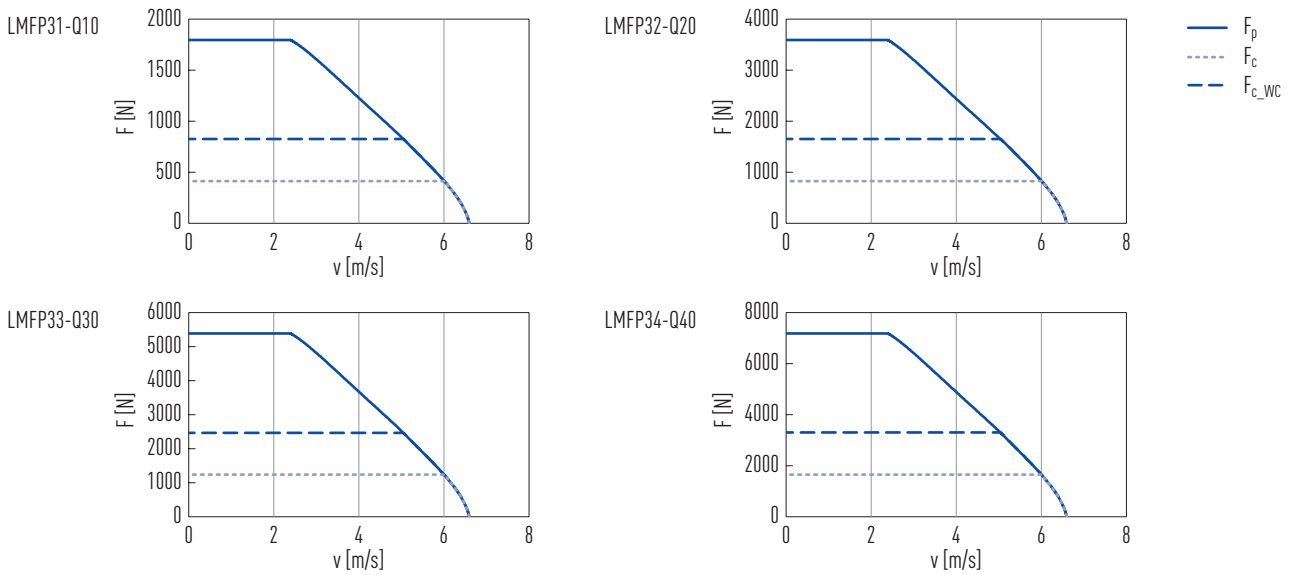

Table 5.2 Technical data for LMFP3

	Symbol	Unit	LMFP31-Q10	LMFP32-Q20	LMFP33-Q30	LMFP34-Q40
Forces and electrical parameters						
Continuous force at T_{max}	F_c	N	413	827	1,240	1,653
Peak force at T_{max} (WC)	F_{c_WC}	N	827	1,653	2,480	3,307
Continuous current at T_{max}	I_c	A_{eff}	4.1	8.2	12.4	16.5
Continuous current at T_{max} (WC)	I_{c_WC}	A_{eff}	8.2	16.5	24.7	33.0
Peak force (for 1 s)	F_p	N	1,797	3,593	5,390	7,187
Peak current (for 1 s)	I_p	A_{eff}	25.6	51.2	76.8	102.4
Force constant	K_f	N/A_{eff}	100.3	100.3	100.3	100.3
Attraction force	F_a	N	3,121	6,243	9,364	12,485
Electrical time constant	K_e	ms	12	12	12	12
Resistance ¹⁾	R_{25}	Ω	3.6	1.8	1.2	0.9
Inductance ¹⁾	L	mH	43.2	21.6	14.4	10.8
Back EMF constant	K_u	$V_{eff}/(m/s)$	57.9	57.9	57.9	57.9
Motor constant	K_m	N/\sqrt{W}	43.3	61.4	74.5	86.2
Thermal resistance	R_{th}	$^{\circ}C/W$	0.77	0.38	0.26	0.19
Thermal resistance (WC)	R_{th_WC}	$^{\circ}C/W$	0.19	0.09	0.06	0.05
Thermal switch			1 × PT1000 + 1 × (3 PTC SNM 120 in series)			
Max. DC bus voltage		V	750			
Mechanical parameters						
Pole pair pitch	2τ	mm	46			
Max. winding temperature	T_{max}	$^{\circ}C$	120			
Mounting holes (forcer)	n		2	4	6	8
Weight of forcer	M_F	kg	6.9	12.1	17.8	23.1
Length of forcer	L_F	mm	221	382	543	704
Unit mass of stator	M_S	kg/m	16.2			
Stator length/mounting holes	L_S	mm	184 mm/N = 2; 460 mm/N = 5			
Total height	H	mm	64.1			

WC: with water cooling

All specifications are in $\pm 10\%$ of tolerance at $25^{\circ}C$ ambient temperature

¹⁾ Line to line

Dimensions of forcer

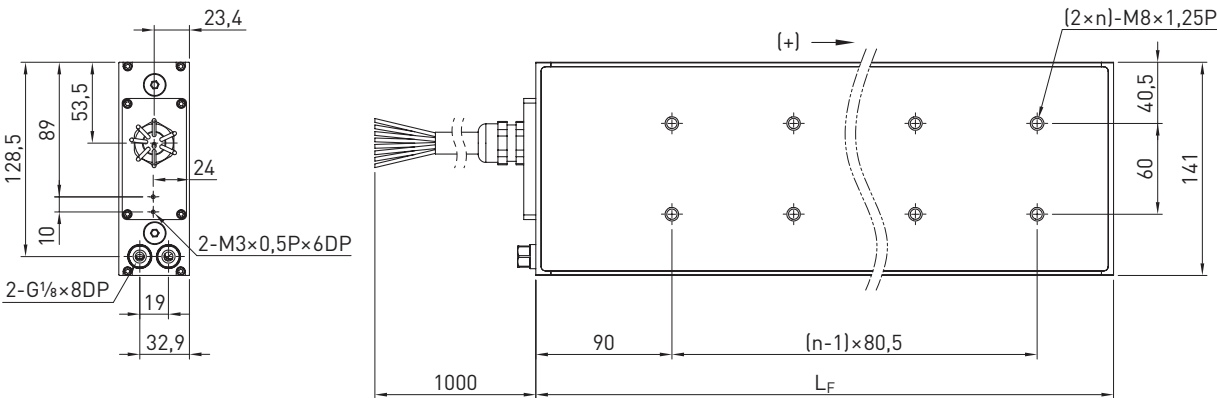

Dimensions of stator

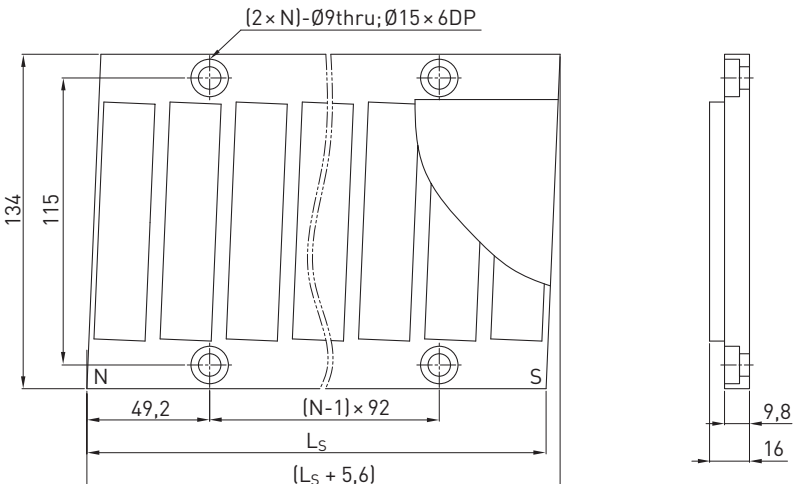

Mounting tolerances

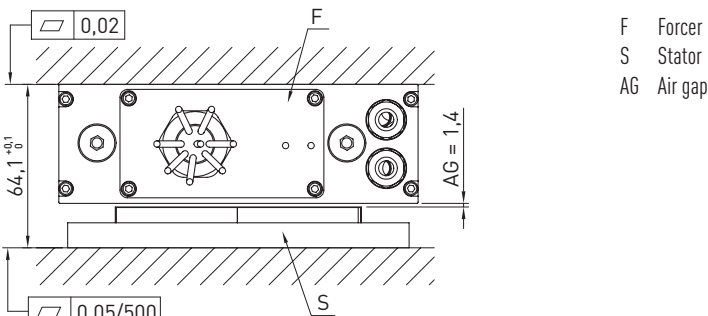

Linear Motors & Distance Measuring Systems

HIWIN LMFP linear motors

5.4.3 LMFP4 linear motor specifications

Force-velocity curves (DC bus voltage: 600 VDC)

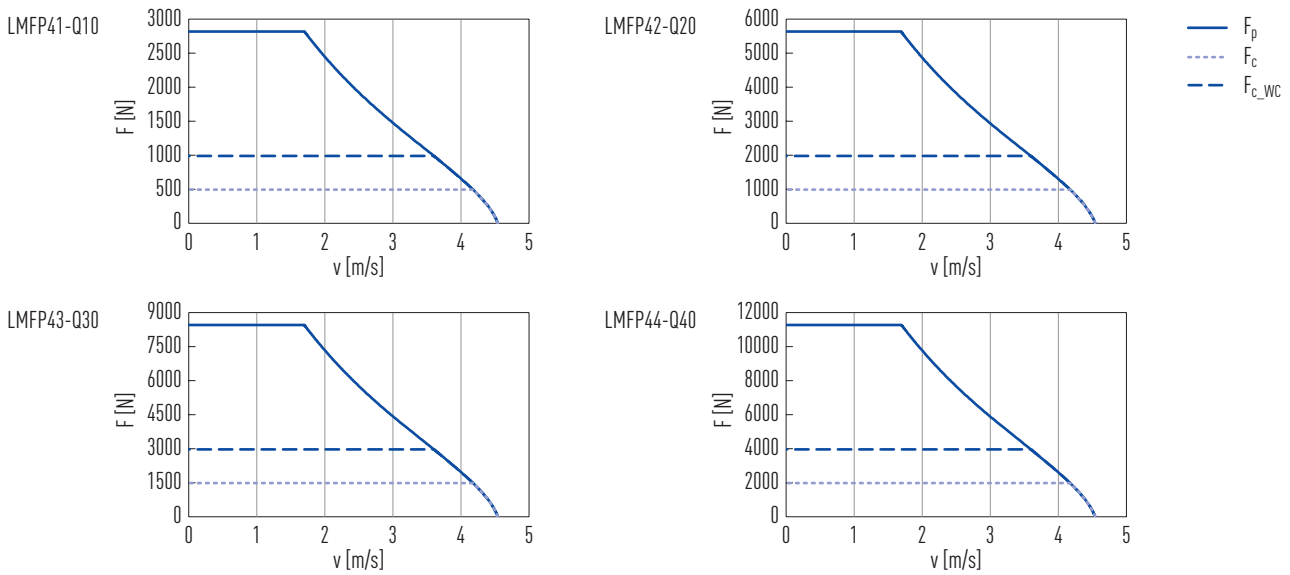

Table 5.3 Technical data for LMFP4

	Symbol	Unit	LMFP41-Q10	LMFP42-Q20	LMFP43-Q30	LMFP44-Q40
Forces and electrical parameters						
Continuous force at T_{max}	F_c	N	495	990	1,485	1,979
Peak force at T_{max} (WC)	F_{c_WC}	N	990	1,979	2,969	3,958
Continuous current at T_{max}	I_c	A_{eff}	3.4	6.8	10.2	13.6
Continuous current at T_{max} (WC)	I_{c_WC}	A_{eff}	6.8	13.6	20.4	27.2
Peak force (for 1 s)	F_p	N	2,820	5,640	8,460	11,280
Peak current (for 1 s)	I_p	A_{eff}	22.7	45.5	68.2	90.9
Force constant	K_f	N/A_{eff}	145.7	145.7	145.7	145.7
Attraction force	F_a	N	4,682	9,363	14,045	18,727
Electrical time constant	K_e	ms	12.6	12.4	12.6	12.4
Resistance ¹⁾	R_{25}	Ω	5.1	2.6	1.7	1.3
Inductance ¹⁾	L	mH	64.5	32.3	21.5	16.1
Back EMF constant	K_u	$V_{eff}/(m/s)$	84.1	84.1	84.1	84.1
Motor constant	K_m	N/\sqrt{W}	52.6	73.7	91.2	104.2
Thermal resistance	R_{th}	$^{\circ}C/W$	0.78	0.38	0.26	0.19
Thermal resistance (WC)	R_{th_WC}	$^{\circ}C/W$	0.20	0.10	0.07	0.05
Thermal switch			1 × PT1000 + 1 × (3 PTC SNM 120 in series)			
Max. DC bus voltage		V	750			
Mechanical parameters						
Pole pair pitch	2τ	mm	46			
Max. winding temperature	T_{max}	$^{\circ}C$	120			
Mounting holes (forcer)	n		2	4	6	8
Weight of forcer	M_F	kg	9.9	16.7	25.0	29.8
Length of forcer	L_F	mm	221	382	543	704
Unit mass of stator	M_S	kg/m	22.3			
Stator length/mounting holes	L_S	mm	184 mm/N = 2; 460 mm/N = 5			
Total height	H	mm	66.1			

WC: with water cooling

All specifications are in $\pm 10\%$ of tolerance at 25 $^{\circ}C$ ambient temperature

¹⁾ Line to line

Dimensions of forcer

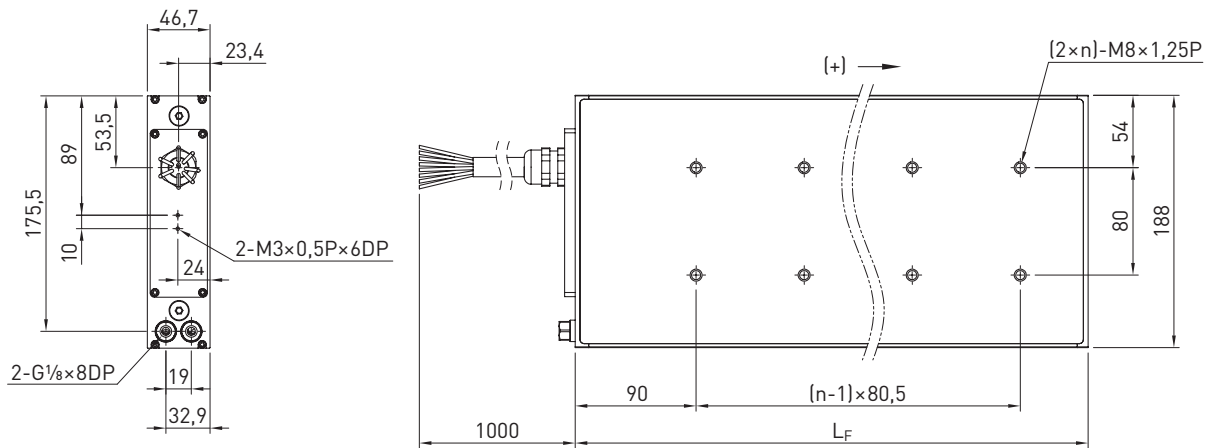

Dimensions of stator

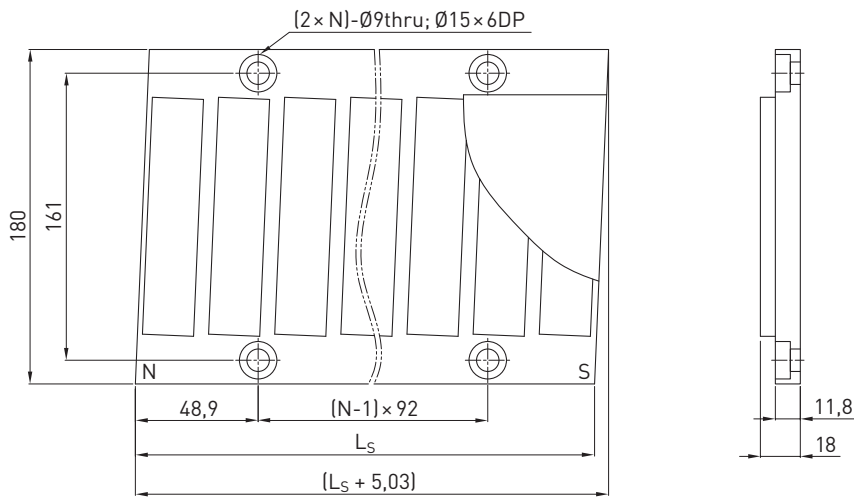

Mounting tolerances

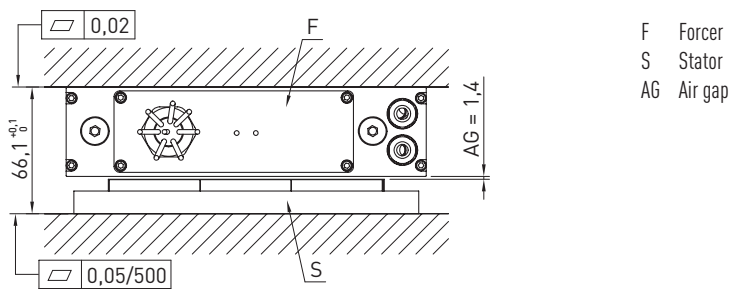

Linear Motors & Distance Measuring Systems

HIWIN LMFP linear motors

5.4.4 LMFP5 linear motor specifications

Force-velocity curves (DC bus voltage: 600 VDC)

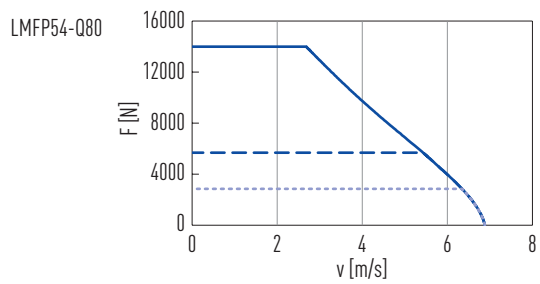
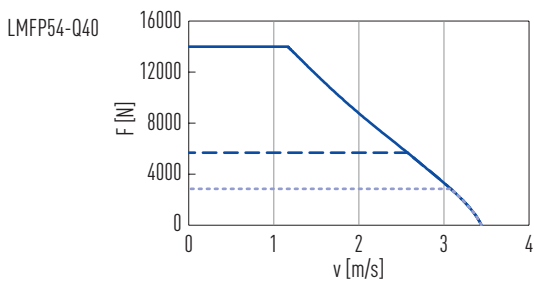
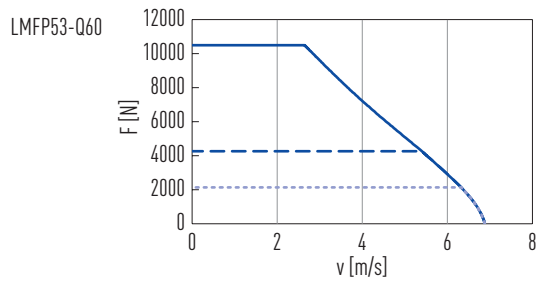
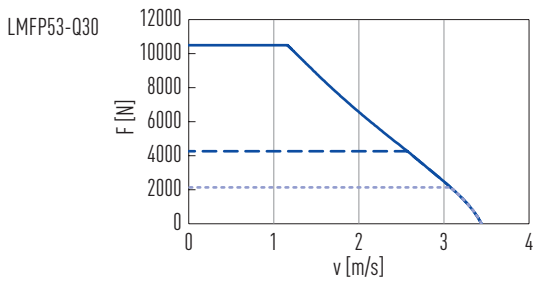
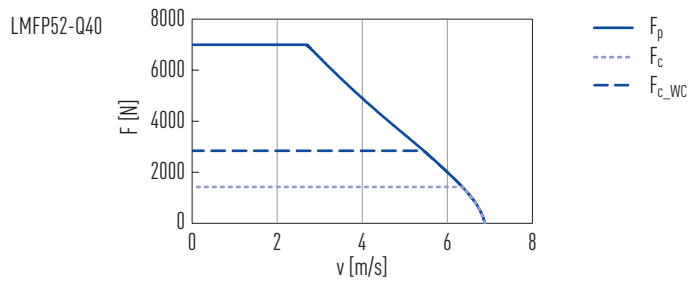
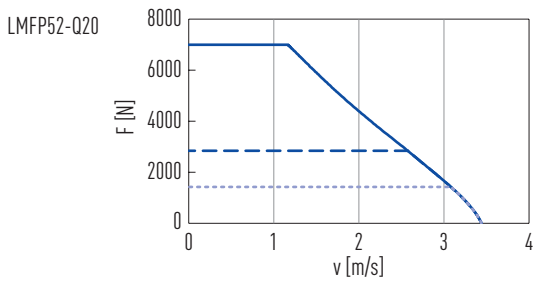

Table 5.4 Technical data for LMFP5

	Symbol	Unit	LMFP52-Q20	LMFP52-Q40	LMFP53-Q30	LMFP53-Q60	LMFP54-Q40	LMFP54-Q80
Forces and electrical parameters								
Continuous force at T_{max}	F_c	N	1,422	1,422	2,133	2,133	2,844	2,844
Peak force at T_{max} (WC)	F_{c_WC}	N	2,844	2,844	4,266	4,266	5,688	5,688
Continuous current at T_{max}	I_c	A_{eff}	7.4	14.8	11.1	22.2	14.8	29.6
Continuous current at T_{max} (WC)	I_{c_WC}	A_{eff}	14.8	29.6	22.2	44.4	29.6	59.2
Peak force (for 1 s)	F_p	N	7,000	7,000	10,500	10,500	14,000	14,000
Peak current (for 1 s)	I_p	A_{eff}	46.3	92.7	69.5	139.0	92.7	185.3
Force constant	K_f	N/A_{eff}	192.3	96.1	192.3	96.1	192.3	96.1
Attraction force	F_a	N	12,467	12,467	18,700	18,700	24,933	24,933
Electrical time constant	K_e	ms	12.6	13.4	12.4	12.0	12.6	13.5
Resistance ¹⁾	R_{25}	Ω	3.4	0.8	2.3	0.6	1.7	0.4
Inductance ¹⁾	L	mH	42.9	10.7	28.6	7.2	21.5	5.4
Back EMF constant	K_u	$V_{eff}/(m/s)$	111.0	55.5	111.0	55.5	111.0	55.5
Motor constant	K_m	N/\sqrt{W}	85.1	87.7	103.5	101.3	120.3	124
Thermal resistance	R_{th}	$^{\circ}C/W$	0.25	0.26	0.16	0.16	0.13	0.14
Thermal resistance (WC)	R_{th_WC}	$^{\circ}C/W$	0.06	0.07	0.04	0.04	0.03	0.04
Thermal switch			1 × PT1000 + 1 × (3 PTC SNM 120 in series)					
Max. DC bus voltage		V	750					
Mechanical parameters								
Pole pair pitch	2τ	mm	46					
Max. winding temperature	T_{max}	$^{\circ}C$	120					
Mounting holes (forcer)	n		4	4	6	6	8	8
Weight of forcer	M_F	kg	24.8	24.8	33.5	33.5	42.3	42.3
Length of forcer	L_F	mm	382	382	543	543	704	704
Unit mass of stator	M_S	kg/m	25					
Stator length/mounting holes	L_S	mm	184 mm/N = 2; 276 mm/N = 3; 460 mm/N = 5					
Total height	H	mm	64.1					

WC: with water cooling

 All specifications are in $\pm 10\%$ of tolerance at 25 $^{\circ}C$ ambient temperature

¹⁾ Line to line

5.4.5 LMFP6 linear motor specifications

Force-velocity curves (DC bus voltage: 600 VDC)

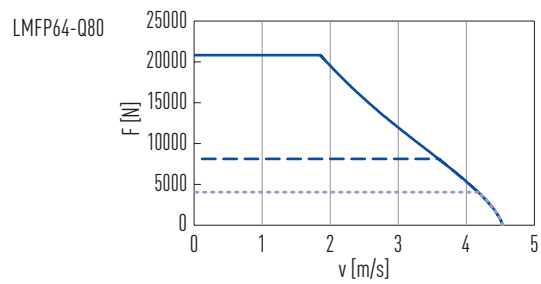
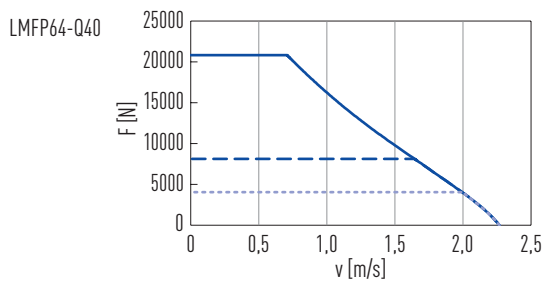
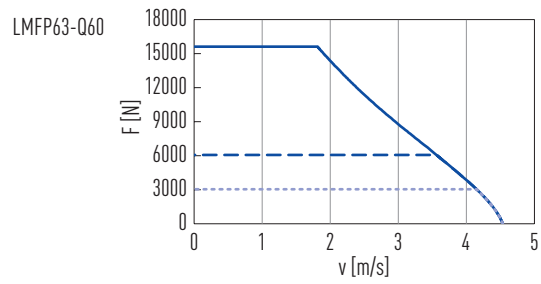
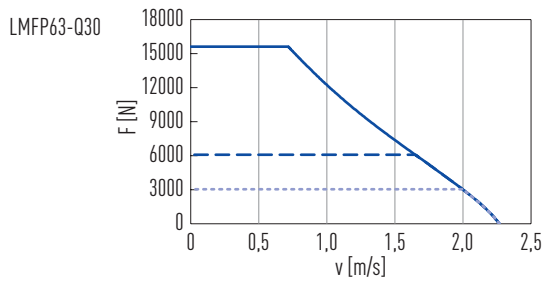
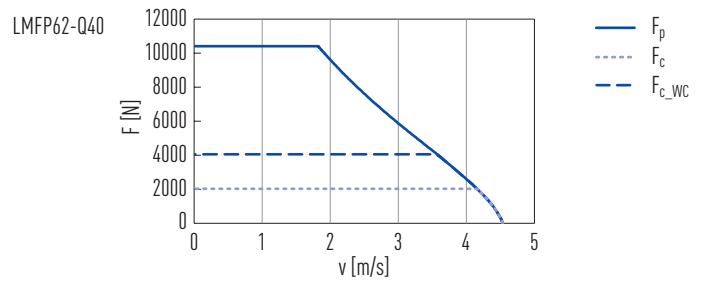
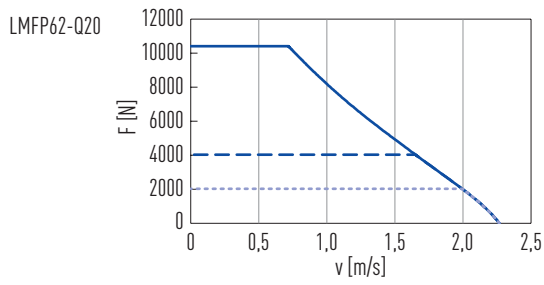

Linear Motors & Distance Measuring Systems

HIWIN LMFP linear motors

Table 5.5 Technical data for LMFP6								
	Symbol	Unit	LMFP62-Q20	LMFP62-Q40	LMFP63-Q30	LMFP63-Q60	LMFP64-Q40	LMFP64-Q80
Forces and electrical parameters								
Continuous force at T_{max}	F_c	N	2,029	2,029	3,043	3,043	4,058	4,058
Peak force at T_{max} (WC)	F_{c_WC}	N	4,057	4,057	6,086	6,086	8,115	8,115
Continuous current at T_{max}	I_c	A_{eff}	7.0	13.9	10.4	20.9	13.9	27.8
Continuous current at T_{max} (WC)	I_{c_WC}	A_{eff}	13.9	27.8	20.9	41.7	27.8	55.7
Peak force (for 1 s)	F_p	N	10,414	10,414	15,620	15,620	20,827	20,827
Peak current (for 1 s)	I_p	A_{eff}	41.9	83.8	62.9	125.7	83.8	167.6
Force constant	K_f	N/A_{eff}	291.7	145.8	291.7	145.8	291.7	145.8
Attraction force	F_a	N	18,727	18,727	28,091	28,091	37,454	37,454
Electrical time constant	K_e	ms	12.6	12.4	12.6	11.9	12.4	13.3
Resistance ¹⁾	R_{25}	Ω	5.1	1.3	3.4	0.9	2.6	0.6
Inductance ¹⁾	L	mH	64.3	16.1	42.9	10.7	32.2	8.0
Back EMF constant	K_u	$V_{eff}/(m/s)$	168.4	84.2	168.4	84.2	168.4	84.2
Motor constant	K_m	N/\sqrt{W}	104.8	104.5	129.6	125.3	147.8	153.9
Thermal resistance	R_{th}	$^{\circ}C/W$	0.18	0.18	0.12	0.12	0.09	0.10
Thermal resistance (WC)	R_{th_WC}	$^{\circ}C/W$	0.05	0.05	0.03	0.03	0.02	0.03
Thermal switch			1 × PT1000 + 1 × (3 PTC SNM 120 in series)					
Max. DC bus voltage		V	750					
Mechanical parameters								
Pole pair pitch	2τ	mm	46					
Max. winding temperature	T_{max}	$^{\circ}C$	120					
Mounting holes (forcer)	n		16	16	24	24	32	32
Weight of forcer	M_F	kg	33.4	33.4	46.7	46.7	57.6	57.6
Length of forcer	L_F	mm	382	382	543	543	704	704
Unit mass of stator	M_S	kg/m	40.1					
Stator length/mounting holes	L_S	mm	184 mm/N = 4					
Total height	H	mm	66.1					

WC: with water cooling

All specifications are in $\pm 10\%$ of tolerance at 25 $^{\circ}C$ ambient temperature

¹⁾ Line to line

Dimensions of forcer

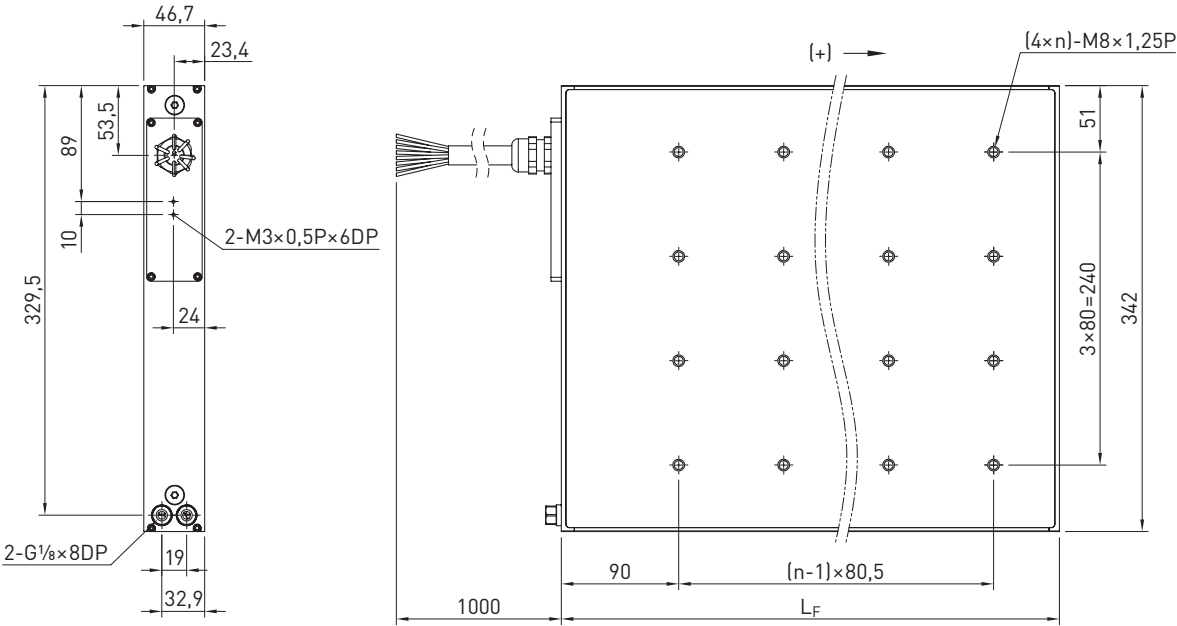

Dimensions of stator

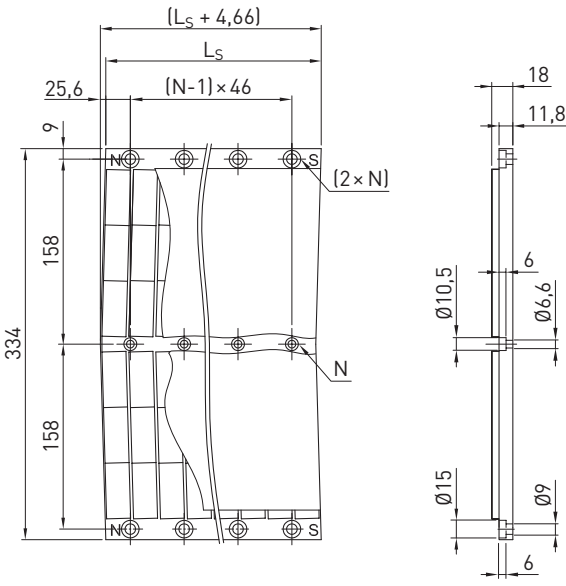

Mounting tolerances

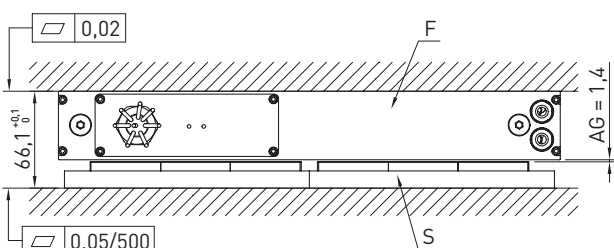

- F Forcer
- S Stator
- AG Air gap

Linear Motors & Distance Measuring Systems

Accessories

6. Accessories

6.1 Stator covers for LMFA/LMFP linear motors

Sheet metal covers made of stainless steel are available for the stators of the HIWIN LMFA and LMFP linear motor series to protect them from mechanical damage.

The light magnetic stator covers are available in segmented or one-piece types. The covers are fixed purely by magnetic attraction force or, in the one-piece type, with an additional clamp at the front.



Fig. 6.1 Segmented stator cover



Fig. 6.2 One-piece stator cover

6.1.1 Segmented stator cover

The segmented stator covers are available for stators of the HIWIN LMFA and LMFP linear motor series in sizes 2 to 6. The segments are available in various fixed lengths that can be lined up to match the overall length of the stator track. The fixation of the cover segments on the stator is ensured by the magnetic attraction between the cover and the permanent magnets of the stator.

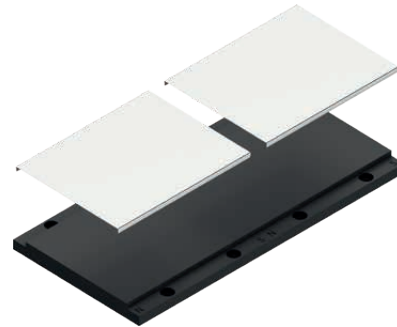

Order code

LMF 4 -CS -L460

Linear motor: _____
Assignment to LMFA/LMFP series

Width of stator cover: _____
3: For LMF3-SxEx stators
4: For LMF4-SxEx stators
5: For LMF5-SxEx stators
6: For LMF6-SxEx stators

Length of cover [mm]:
Length of segmented cover, see
table for available lengths per size
Cover strip:
CS: Cover segmented

Specifications of segmented stator covers

Designation ¹⁾	Suitable for stators	Available segment lengths [mm]
LMF2-CS-Lxxx	LMF2SxE, LMF2SxEG, LMF2SxEP	300, 360, 420, 480, 600
LMF3-CS-Lxxx	LMF3SxE, LMF3SxEG, LMF3SxEP	460, 552, 644, 736, 920
LMF4-CS-Lxxx	LMF4SxE, LMF4SxEG, LMF4SxEP	460, 552, 644, 736, 920
LMF5-CS-Lxxx	LMF5SxE, LMF5SxEG, LMF5SxEP	460, 552, 644, 736, 920
LMF6-CS-Lxxx	LMF6SxE, LMF6SxEG, LMF6SxEP	460, 552, 644, 736, 920

¹⁾ x = Length of stators

6.1.2 One-piece stator covers

The one-piece stator cover is available for stators of the HIWIN LMFA and LMFP linear motor series in widths 3 to 6. The one-piece cover is customised to the overall length of the stator track. The end blocks have recesses to which the ends of the cover are clamped with strips for mechanical fixation. The magnetic attraction additionally ensures that the cover sits reliably along the entire length of the stator.

When using the one-piece stator cover, two matching end block sets are always required for fixing.

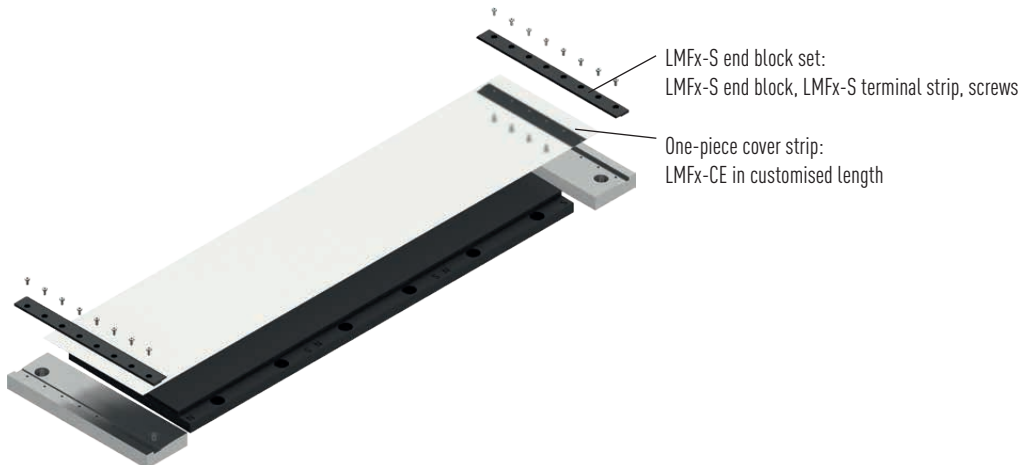

Order code

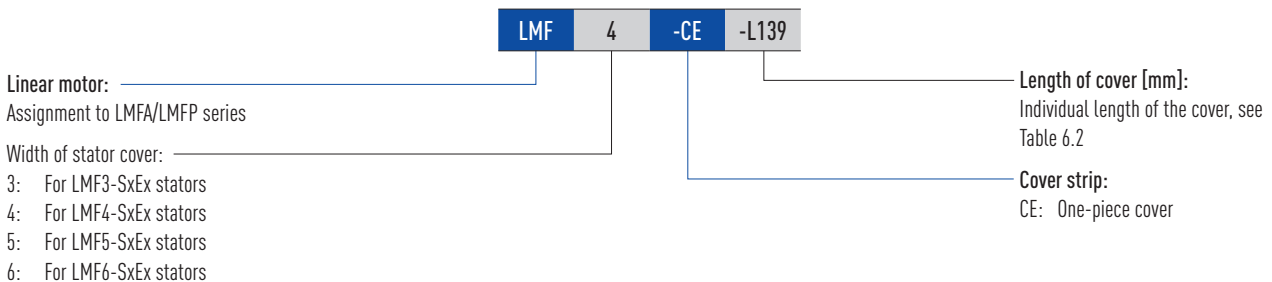

Specifications of one-piece stator covers

Table 6.2 One-piece stator covers

Designation	Suitable for series	Length of cover [mm]	Required end block set
LMF2-CE-Lx ¹⁾	LMFA2, LMFP2	Length of the stator track + 76	LMF2-S end block set
LMF3-CE-Lx ¹⁾	LMFA3, LMFP3	Length of the stator track + 108	LMF3-S end block set
LMF4-CE-Lx ¹⁾	LMFA4, LMFP4	Length of the stator track + 108	LMF4-S end block set
LMF5-CE-Lx ¹⁾	LMFA5, LMFP5	Length of the stator track + 108	LMF5-S end block set
LMF6-CE-Lx ¹⁾	LMFA6, LMFP6	Length of the stator track + 108	LMF6-S end block set

¹⁾ x = Length in mm (max. 50.000)

Table 6.3 End block sets

Designation ¹⁾	Suitable for series	Required cover strip
LMF2-S end block set	LMFA2/LMFP2	LMF2-CE (One-piece stator cover)
LMF3-S end block set	LMFA3/LMFP3	LMF3-CE (One-piece stator cover)
LMF4-S end block set	LMFA4/LMFP4	LMF4-CE (One-piece stator cover)
LMF5-S end block set	LMFA5/LMFP5	LMF5-CE (One-piece stator cover)
LMF6-S end block set	LMFA6/LMFP6	LMF6-CE (One-piece stator cover)

¹⁾ 2 end block sets are required to fix the one-piece stator cover (one end block set per side). Each end block set consists of 1× end block, 1× terminal strip and matching mounting bolts.

Linear Motors & Distance Measuring Systems

Accessories

6.2 LMFC precision cooler for LMFA/LMFP linear motors

Precision coolers for forcer (primary part) and stator (secondary part) are available as optional accessories for the water-cooled HIWIN LMFA/LMFP linear motors. By using LMFC precision cooling, extensive thermal decoupling can be achieved between the linear motor components and the machine, which reduces the heat transfer from the linear motor to the working chamber of the machine to a minimum. By using precision cooling, stable thermal conditions can be created, which are a basic requirement for precision machining with the highest demands on dimensional accuracy, such as in precision grinding machines and other temperature-critical applications. The more powerful cooling of the linear motor due to the precision cooler also leads to an increase in efficiency and lower electrical power consumption compared to operation without precision cooling thanks to the lower coil temperatures.



Fig. 6.3 LMFP41 linear motor with precision cooling for forcer and stator and one-piece stator cover

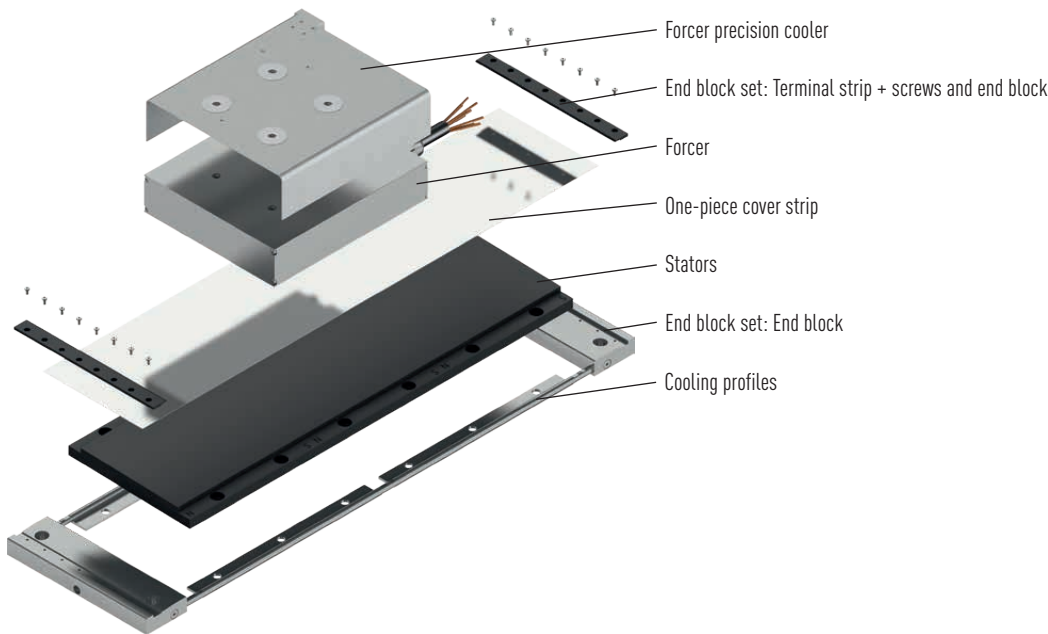

Fig. 6.4 Explosion: LMFP41 linear motor with precision cooling for forcer and stator and one-piece stator cover

6.2.1 Forcer precision cooling

Since the electrical power is mainly converted in the forcer or primary part of the linear motor and most of the waste heat is generated there, the greatest improvements can be achieved using the precision cooler on the forcer.

The precision cooler is assembled on the forcer and integrated into the existing cooling circuit. In order to achieve the best possible effect, the coolant inlet of the precision cooler (forcer) should be connected directly to the coolant outlet of the cooling system of the machine. Likewise, the coolant outlet of the precision cooler should be connected to the coolant inlet of the forcer. This ensures the best possible thermal decoupling and cooling of the linear motor.

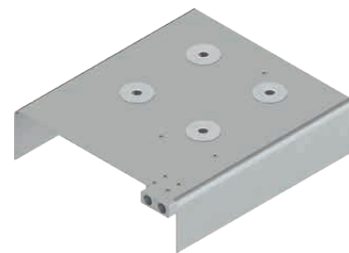

Fig. 6.5 LMFP41-Q10-0-100F with LMFC41 forcer precision cooling

Order code

LMFC 4 1

Linear motor:
LMFC

Width of forcer cooler:
3: LMFA3/LMFP3 series
4: LMFA4/LMFP4 series
5: LMFA5/LMFP5 series
6: LMFA6/LMFP6 series

Length of forcer cooler

- 1: LMFAx1
- 2: LMFAx2
- 3: LMFAx3
- 4: LMFAx4

Example:

Primary cooler: LMFC41

Suitable for forcer: LMFA41, LMFA41L; LMFP41-Q10

Dimensions Forcer LMFC3,4

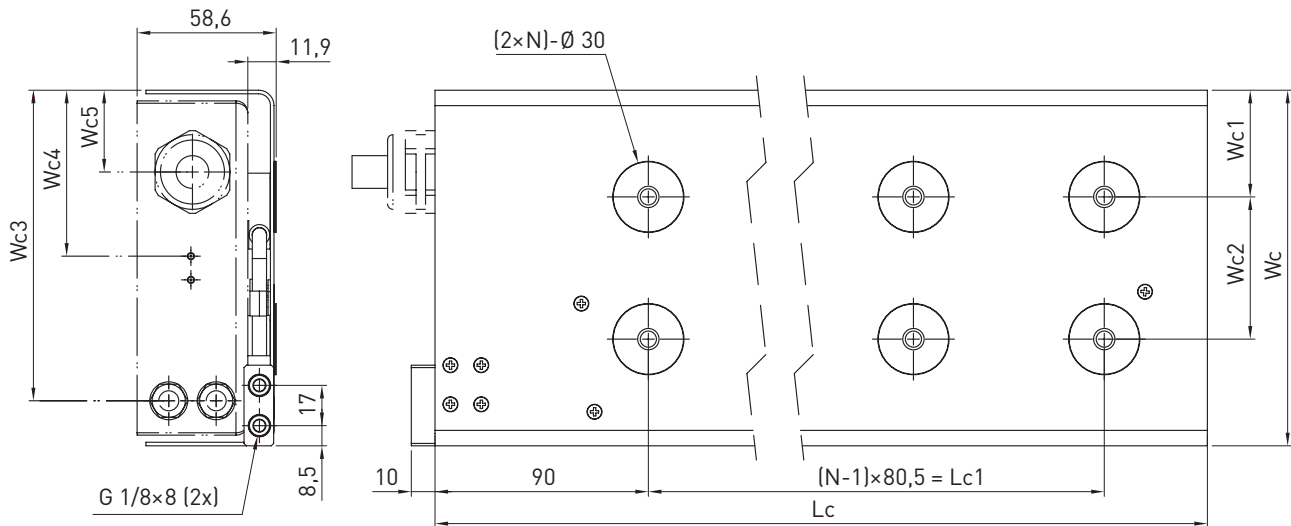

Table 6.4 Dimensions Forcer LMFC3,4

Article number	Designation	Suitable for series	Lc	Lc1	Wc	Wc1	Wc2	Wc3	Wc4	Wc5	N
8-76-0560	LMFC31	LMFA31, LMFP31	214	80.5	150	45.0	60	131	70.0	34.5	2
8-76-0561	LMFC32	LMFA32, LMFP32	375	241.5	150	45.0	60	131	70.0	34.5	4
8-76-0562	LMFC33	LMFA33, LMFP33	536	402.5	150	45.0	60	131	70.0	34.5	6
8-76-0563	LMFC34	LMFA34, LMFP34	697	563.5	150	45.0	60	131	70.0	34.5	8
8-76-0586	LMFC41	LMFA41, LMFP41	214	80.5	197	58.5	80	178	93.5	34.5	2
8-76-0587	LMFC42	LMFA42, LMFP42	375	241.5	197	58.5	80	178	93.5	34.5	4
8-76-0588	LMFC43	LMFA43, LMFP43	563	402.5	197	58.5	80	178	93.5	34.5	6
8-76-0589	LMFC44	LMFA44, LMFP44	697	563.5	197	58.5	80	178	93.5	34.5	8

Linear Motors & Distance Measuring Systems

Accessories

Dimensions Forcer LMFC5,6

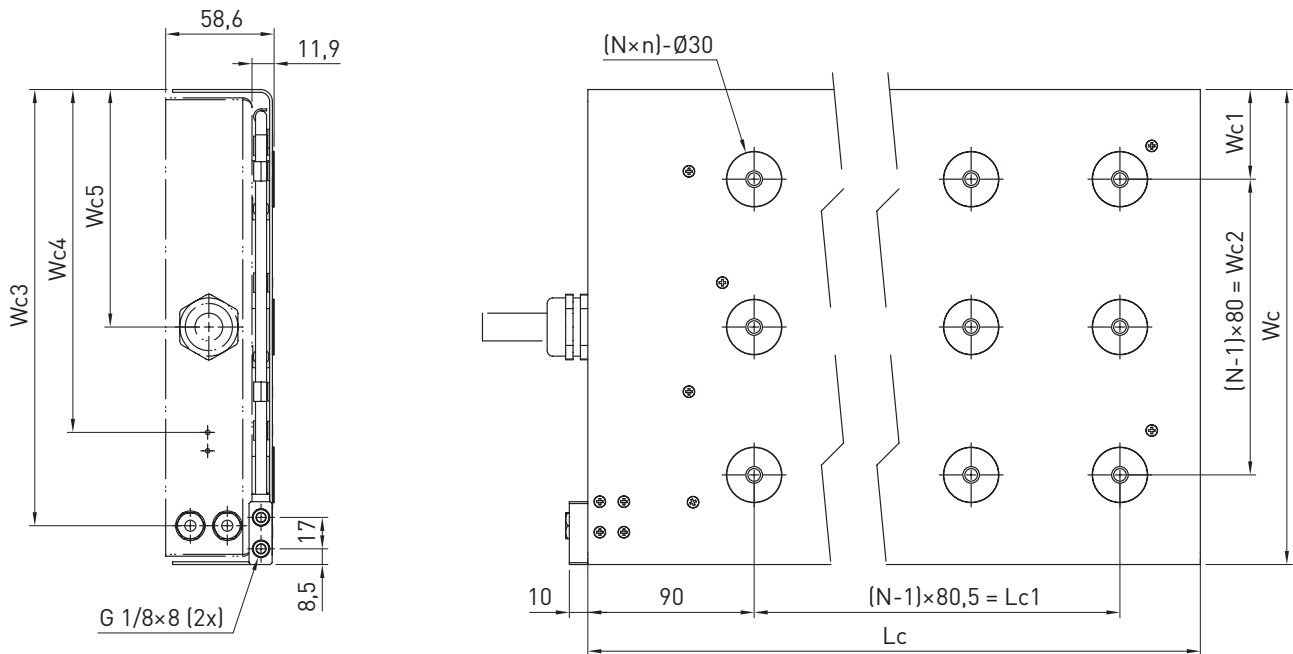

Table 6.5 Dimensions Forcer LMFC5,6

Article number	Designation	Suitable for series	Lc	Lc1	Wc	Wc1	Wc2	Wc3	Wc4	Wc5	N	n
8-76-0571	LMFC52	LMFA52, LMFP52	375	241.5	257	48.5	160	236	185.5	128.5	3	4
8-76-0572	LMFC53	LMFA53, LMFP53	536	402.5	257	48.5	160	236	185.5	128.5	3	6
8-76-0574	LMFC54	LMFA54, LMFP54	697	563.5	257	48.5	160	236	185.5	128.5	3	8
8-76-0564	LMFC62	LMFA62, LMFP62	375	241.5	351	55.5	240	330	249.5	175.5	4	4
8-76-0565	LMFC63	LMFA63, LMFP63	536	402.5	351	55.5	240	330	249.5	175.5	4	6
8-76-0566	LMFC64	LMFA64, LMFP64	697	563.5	351	55.5	240	330	249.5	175.5	4	8

6.2.2 Stator precision cooling

By using stator precision cooling together with our HIWIN linear motors of the LMFA and LMFP series and forcer precision cooling, the thermal decoupling between linear motor and machine can be improved even more. Especially in short-stroke applications, the stators can also reach relatively high surface temperatures, which leads to undesired heat dissipation to the application. Stator precision cooling effectively prevents this heat dissipation by moving the heat from the stator to the cooling circuit via the coolant. This contributes to a lower and more stable temperature level in the machine.



6.2.2.1 Standard variant with two-sided cooler connections

The standard stator precision cooling type is characterised by the use of two identical end blocks, each with a connection for the cooler lines. The coolant flows into the end block via the inlet at the first end block and is distributed to the individual cooling profiles through channels in the interior. This creates several parallel coolant flows that absorb heat from the stator as they flow through the cooling profiles and are recombined into one coolant flow in the second end block at the end of the stator (see Fig. 7.6). The standard stator cooling variant is available for LMFA and LMFP linear motors of the 3 to 6 series and uses two identical end blocks available with and without clamping device for the one-piece cover strip.



Fig. 6.6 Standard LMFC precision-cooling stator variant

Dimensions LMFC 3,4 stator precision cooling in standard type

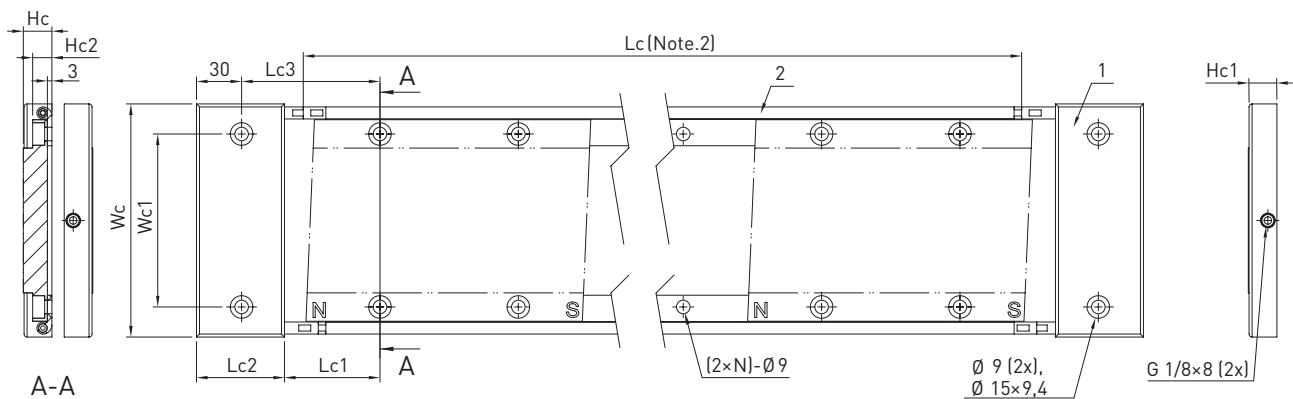

- 1 End block
- 2 Cooling profile

Size	Designation	End block	Lc	Lc1	Lc2	Lc3	Wc	Wc1	Hc	Hc1	Hc2
LMFC3	LMFC3 Stator precision cooling	LMFC3-S/LMFC3-S-G	—	63.5	58.5	92	155	115	19	18.5	13
LMFC4	LMFC4 Stator precision cooling	LMFC4-S/LMFC4-S-G	—	63.5	58.5	92	201	161	21	20.5	15

Linear Motors & Distance Measuring Systems

Accessories

Dimensions LMFC 5,6 stator precision cooling in standard type

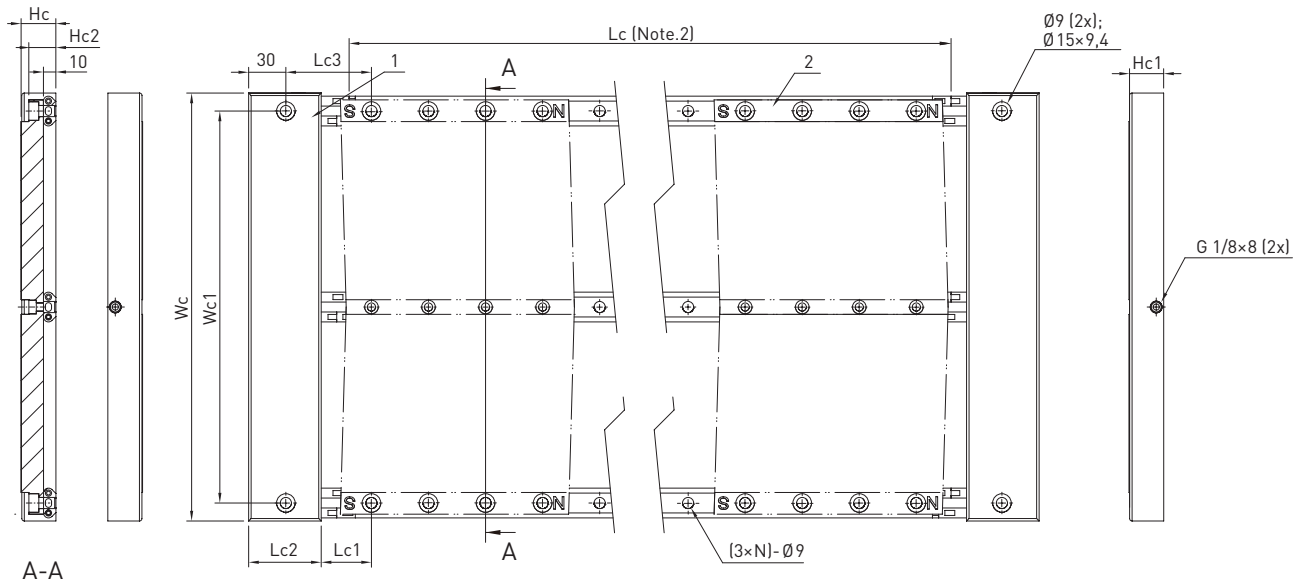

- 1 End block
- 2 Cooling profile

Table 6.8 Dimensions LMFC 5,6 stator precision cooling in standard type

Baugröße	Designation	End block	Lc	Lc1	Lc2	Lc3	Wc	Wc1	Hc	Hc1	Hc2
LMFC5	LMFC5 Stator precision cooling	LMFC5-S/LMFC5-S-G	—	40.5	58.5	69	251	222	26	25.5	19.8
LMFC6	LMFC6 Stator precision cooling	LMFC6-S/LMFC6-S-G	—	40.5	58.5	69	345	316	28	27.5	21.8

6.2.2.2 End blocks and end block sets for the standard stator precision cooling variant

End blocks for segmented stator cover/without stator cover



Table 6.7 End blocks for segmented stator cover/without stator cover

Article number	Designation	Suitable for motor series	Suitable for cover strip
8-12-1017 ¹⁾	LMFC3-S End block	LMFA3/LMFP3	LMF3-CS-Lxxx/without cover
8-12-1020 ¹⁾	LMFC4-S End block	LMFA4/LMFP4	LMF4-CS-Lxxx/without cover
8-12-1023 ¹⁾	LMFC5-S End block	LMFA5/LMFP5	LMF5-CS-Lxxx/without cover
8-12-1024 ¹⁾	LMFC6-S End block	LMFA6/LMFP6	LMF6-CS-Lxxx/without cover

¹⁾ When ordering, please note that two end blocks are required (one end block per side).

End block sets with clamp for one-piece stator cover



Table 6.9 End block sets with clamp for one-piece stator cover

Article number	Designation	Suitable for motor series	Suitable for cover strip
8-12-1284 ¹⁾	LMFC3-S-G End block set	LMFA3/LMFP3	LMF3-CE (One-piece stator cover)
8-12-1287 ¹⁾	LMFC4-S-G End block set	LMFA4/LMFP4	LMF4-CE (One-piece stator cover)
8-12-1270 ¹⁾	LMFC5-S-G End block set	LMFA5/LMFP5	LMF5-CE (One-piece stator cover)
8-12-1283 ¹⁾	LMFC6-S-G End block set	LMFA6/LMFP6	LMF6-CE (One-piece stator cover)

¹⁾ When ordering, please note that two end block sets are required (one end block set per side). Each end block set consists of 1× end block, 1× terminal strip and matching mounting bolts.

End blocks and end block sets for the special stator cooling variant

The special variant of secondary cooling uses two different end blocks. The first end block contains the two connections for the inlet and outlet of the coolant, while the second end block closes the cooling circuit. The coolant flows through the inlet at the first end block, over the first cooling profile and absorbs heat from the stator. The already heated coolant then flows through the second end block. It flows through the second cooling profile, absorbing heat from the stator and heating up more before leaving the stator cooling area via the coolant outlet of the first end block (see Fig. 6.7).

In contrast to the standard variant with several parallel coolant flows, the special variant features only one coolant flow, which leads to a comparatively lower cooling capacity and higher pressure losses. The special variant should therefore only be used for stators with a maximum length of 2,000 mm. Stator precision cooling is particularly suitable where space is tight and access to the stator track is poor, as the cooler connections only need to be accessible from one side during assembly or for maintenance and repairs. There is also less work required for routing as well as shorter cooler lines, as only one end block needs to be connected to the cooling system. The special stator precision cooling variant is available for LMFA and LMFP linear motors of the 3 and 4 series. The two end block types are optionally available with or without clamping device for the one-piece cover strip.



Fig. 6.7 Cooling circuit of the special stator cooling variant

Linear Motors & Distance Measuring Systems

Accessories

Dimensions LMFC 3,4 stator precision cooling in special type

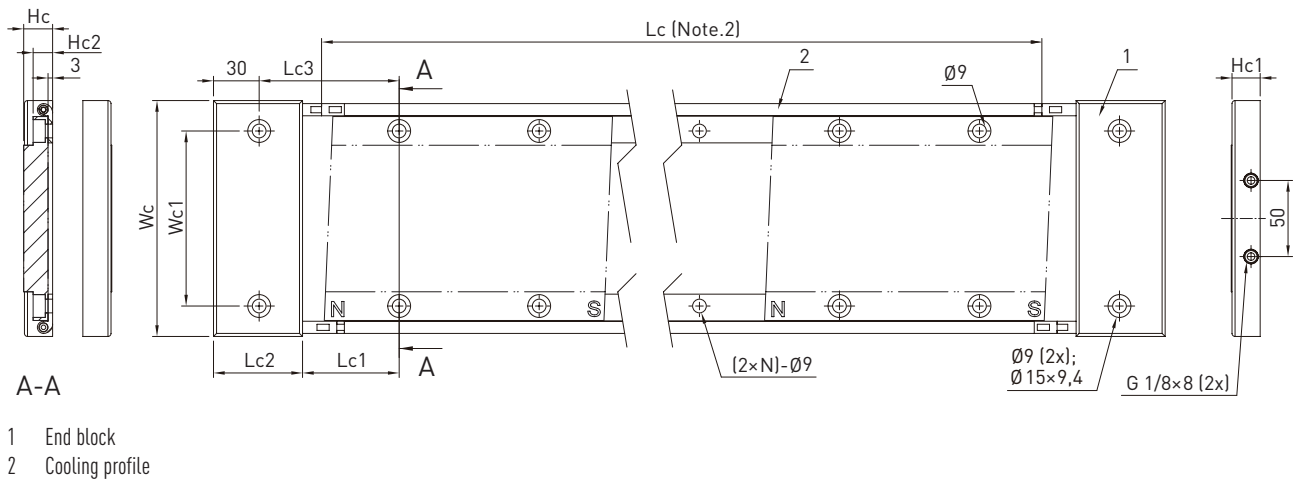

Table 6.11 Dimensions LMFC 3,4 stator precision cooling in special type

Size	Designation	End block	Lc	Lc1	Lc2	Lc3	Wc	Wc1	Hc	Hc1	Hc2
LMFC3	LMFC3 Stator precision cooling	LMFC3-R-C(-G) + LMFC3-R-IO(-G)	-	63.5	58.5	92	155	115	19	18.5	13
LMFC4	LMFC4 Stator precision cooling	LMFC4-R-C(-G) + LMFC4-R-IO(-G)	-	63.5	58.5	92	201	161	21	20.5	15

End blocks for the special variant with segmented stator cover/without stator cover



Fig. 6.8 LMFC4-R-IO end block with inlet and outlet holes for connection to the cooling system of the machine at the beginning of the stator track

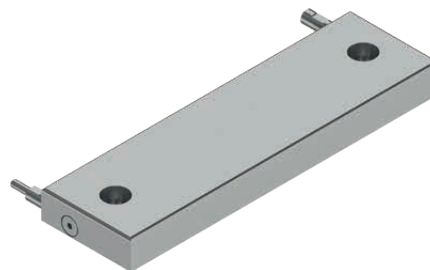

Fig. 6.9 LMFC4-R-C end block for recirculating the coolant at the end of the stator track

Table 6.10 End blocks for the special variant with segmented stator cover/without stator cover

Article number	Designation	Suitable for series	Suitable for cover strip
8-12-1018 ¹⁾	LMFC3-R-C End block	LMFA3/LMFP3	LMF3-CS-Lxxx/without cover
8-12-1019 ¹⁾	LMFC3-R-IO End block	LMFA3/LMFP3	LMF3-CS-Lxxx/without cover
8-12-1021 ¹⁾	LMFC4-R-C End block	LMFA4/LMFP4	LMF4-CS-Lxxx/without cover
8-12-1022 ¹⁾	LMFC4-R-IO End block	LMFA4/LMFP4	LMF4-CS-Lxxx/without cover

¹⁾ When ordering, please note that one end block set each of type LMFCx-RC and LMFCx-R-IO is required.

End block sets for special variant with one-piece stator cover

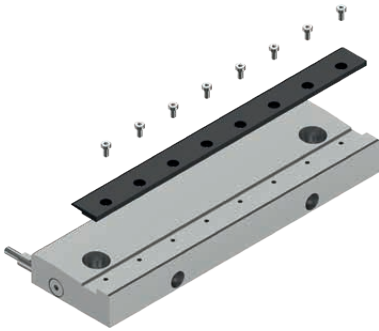

Fig. 6.10 LMFC4-R-I-O-G end block with inlet and outlet holes for connection to the cooling system

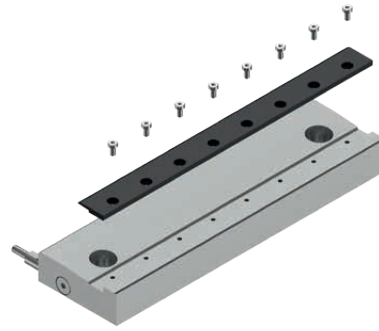

Fig. 6.11 LMFC4-R-C-G end block for recirculating the coolant at the end of the stator track

Table 6.12 End block sets for special variant with one-piece stator cover

Article number	Designation	Suitable for series	Suitable for cover strip
8-12-1285 ¹⁾	LMFC3-R-C-G End block set	LMFA3/LMFP3	LMF3-CE (One-piece stator cover)
8-12-1286 ¹⁾	LMFC3-R-IO-G End block set	LMFA3/LMFP3	LMF3-CE (One-piece stator cover)
8-12-1288 ¹⁾	LMFC4-R-C-G End block set	LMFA4/LMFP4	LMF4-CE (One-piece stator cover)
8-12-1289 ¹⁾	LMFC4-R-IO-G End block set	LMFA4/LMFP4	LMF4-CE (One-piece stator cover)

¹⁾ When ordering, please note that one end block set each of type LMFCx-RC and LMFCx-R-IO is required. Each end block set consists of 1× end block, 1× terminal strip and matching mounting bolts.

6.2.2.3 Cooling profiles

The cooling profiles of the stator precision cooling serve as coolant lines between the end blocks. They transfer the heat from the stators to the coolant flowing through them in order to effectively dissipate the heat from the secondary part of the linear motor and ultimately from the application. In order to satisfy the versatile requirements and different system dimensions, the cooling profiles are available in different lengths and can be plugged into each other using the intuitive plug-in connection to match the length of the stator track.

The cooling profiles of the LMFC3-P series for stators of the LMF3S and LMF4S series have a single coolant line and combine a compact design with reliable heat dissipation from the machine. For this size of stator cooling, a total of two strands of identical cooling profiles run parallel between the end blocks. When ordering, you must therefore note that each individual cooling profile is required twice in total to close the cooling circuit.

Due to the higher power consumption of the LMFA5/LMFP5 and LMFA6/LMFP6 linear motors, the cooling profiles of the LMFC5-P and LMFC6-P series use a design with two parallel coolant lines per cooling profile to ensure sufficient heat dissipation even at maximum load. For the best possible heat dissipation from the stator surface, a total of three strands of identical cooling profiles run parallel between the end blocks.

When ordering, you must therefore note that each individual cooling profile is required three times in total to close the cooling circuit.



Fig. 6.12 LMFC3/4 stator precision cooling: Example arrangement of the cooling profiles and end blocks



Fig. 6.13 LMFC5/6 stator precision cooling: Example arrangement of the cooling profiles and end blocks

Linear Motors & Distance Measuring Systems

Accessories

Dimensions of cooling profiles for sizes LMFC3 and LMFC4

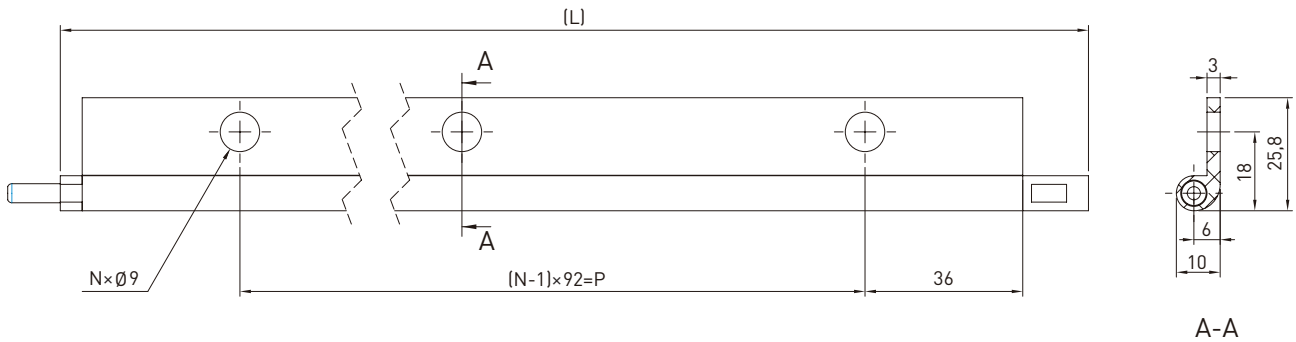

Table 6.13 Dimensions cooling profiles LMFC3,4

Article number	Designation	Suitable for end block	L [mm]	N	P [mm]
8-76-0204 ¹⁾	LMFC3-P-0092	LMFC3-x, LMFC4-x	92	1	0
8-76-0205 ¹⁾	LMFC3-P-0184	LMFC3-x, LMFC4-x	184	2	92
8-76-0206 ¹⁾	LMFC3-P-0276	LMFC3-x, LMFC4-x	276	3	184
8-76-0207 ¹⁾	LMFC3-P-0368	LMFC3-x, LMFC4-x	368	4	276
8-76-0208 ¹⁾	LMFC3-P-0460	LMFC3-x, LMFC4-x	460	5	368
8-76-0209 ¹⁾	LMFC3-P-0552	LMFC3-x, LMFC4-x	552	6	460
8-76-0210 ¹⁾	LMFC3-P-0644	LMFC3-x, LMFC4-x	644	7	552
8-76-0211 ¹⁾	LMFC3-P-0736	LMFC3-x, LMFC4-x	736	8	644
8-76-0212 ¹⁾	LMFC3-P-0828	LMFC3-x, LMFC4-x	828	9	736
8-76-0213 ¹⁾	LMFC3-P-0920	LMFC3-x, LMFC4-x	920	10	828
8-76-0214 ¹⁾	LMFC3-P-1012	LMFC3-x, LMFC4-x	1,012	11	920
8-76-0215 ¹⁾	LMFC3-P-1104	LMFC3-x, LMFC4-x	1,104	12	1,012
8-76-0216 ¹⁾	LMFC3-P-1196	LMFC3-x, LMFC4-x	1,196	13	1,104
8-76-0217 ¹⁾	LMFC3-P-1288	LMFC3-x, LMFC4-x	1,288	14	1,196

¹⁾ The LMFC3/LMFC4 stator precision cooling system has two parallel cooling profile strands. When ordering, please note that two pieces per cooling profile are required to close the cooling circuit.

Dimensions of cooling profiles for size LMFC5

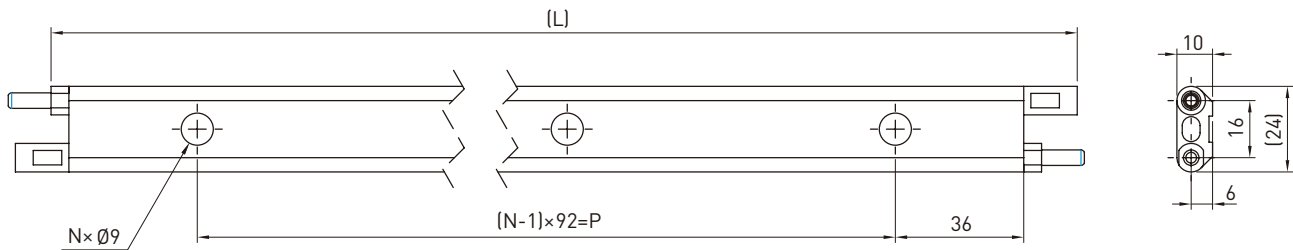

Table 6.14 Dimensions cooling profiles LMFC5

Article number	Designation	Suitable for end block	L [mm]	N	P [mm]
8-76-0218 ¹⁾	LMFC5-P-0092	LMFC5-x	92	1	0
8-76-0219 ¹⁾	LMFC5-P-0184	LMFC5-x	184	2	92
8-76-0220 ¹⁾	LMFC5-P-0276	LMFC5-x	276	3	184
8-76-0221 ¹⁾	LMFC5-P-0368	LMFC5-x	368	4	276
8-76-0222 ¹⁾	LMFC5-P-0460	LMFC5-x	460	5	368
8-76-0223 ¹⁾	LMFC5-P-0552	LMFC5-x	552	6	460
8-76-0224 ¹⁾	LMFC5-P-0644	LMFC5-x	644	7	552
8-76-0225 ¹⁾	LMFC5-P-0736	LMFC5-x	736	8	644
8-76-0226 ¹⁾	LMFC5-P-0828	LMFC5-x	828	9	736
8-76-0227 ¹⁾	LMFC5-P-0920	LMFC5-x	920	10	828
8-76-0228 ¹⁾	LMFC5-P-1012	LMFC5-x	1,012	11	920
8-76-0229 ¹⁾	LMFC5-P-1104	LMFC5-x	1,104	12	1,012
8-76-0230 ¹⁾	LMFC5-P-1196	LMFC5-x	1,196	13	1,104
8-76-0231 ¹⁾	LMFC5-P-1288	LMFC5-x	1,288	14	1,196

¹⁾ The LMFC5 stator precision cooling has three parallel cooling profile strands. When ordering, please note that three pieces per cooling profile are required to close the cooling circuit.

Dimensions of cooling profiles for size LMFC6

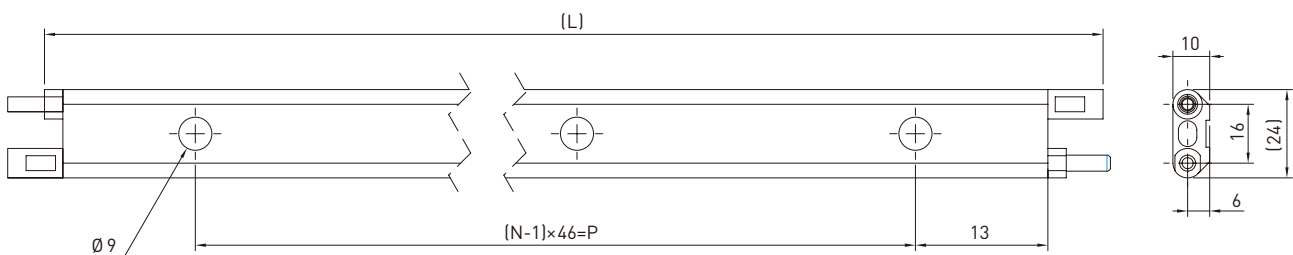

Table 6.15 Dimensions cooling profiles LMFC6

Article number	Designation	Suitable for end block	L [mm]	N	P [mm]
8-76-0232 ¹⁾	LMFC6-P-0184	LMFC6-x	184	4	138
8-76-0233 ¹⁾	LMFC6-P-0368	LMFC6-x	368	8	322
8-76-0234 ¹⁾	LMFC6-P-0552	LMFC6-x	552	12	506
8-76-0235 ¹⁾	LMFC6-P-0736	LMFC6-x	736	16	690
8-76-0236 ¹⁾	LMFC6-P-0920	LMFC6-x	920	20	874
8-76-0237 ¹⁾	LMFC6-P-1104	LMFC6-x	1,104	24	1,058
8-76-0238 ¹⁾	LMFC6-P-1288	LMFC6-x	1,288	28	1,242

¹⁾ The LMFC6 stator precision cooling has three parallel cooling profile strands. When ordering, please note that three pieces per cooling profile are required to close the cooling circuit.

Linear Motors & Distance Measuring Systems

Accessories

6.3 Hall sensors

Hall sensors with analogue and digital output signal are available for each linear motor. The analogue Hall sensors have a sin/cos output signal of 1 V_{pp} (see Fig. 6.14). The digital Hall sensors have three square signals offset through 120° (see Fig. 6.15).

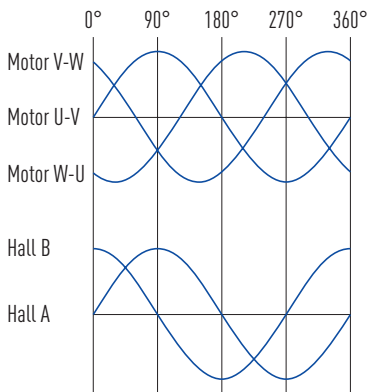

Fig. 6.14 Output signal from analogue Hall sensor with differential output

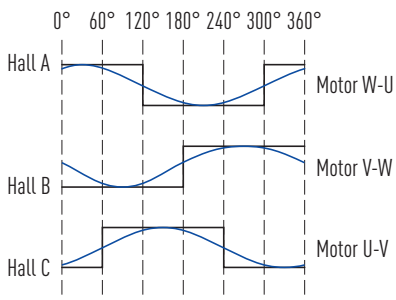

Fig. 6.15 Output signal from digital Hall sensor with single ended output

Table 6.16 Article numbers for Hall sensors

Article number	Version	Motor
8-08-0330	Digital	LMSA1, LMSA2, LMSA3, LMSAC
8-08-0386	Digital	LMCA, LMCB, LMCC
8-08-0422	Digital	LMCE
8-08-0454	Digital	LMFA0, LMFA2, LMFA2
8-08-0519	Digital	LMFA3, LMFA4, LMFA5, LMFA6
8-08-0369	Analogue	LMSA1, LMSA2, LMSA3, LMSAC
8-08-0432	Analogue	LMCA, LMCB, LMCC
8-08-0456	Analogue	LMFA0, LMFA2, LMFA2
8-08-0368	Analogue	LMFA3, LMFA4, LMFA5, LMFA6

6.4 Motor extension cables

6.4.1 Extension cables for linear motors LMSA and LMFA

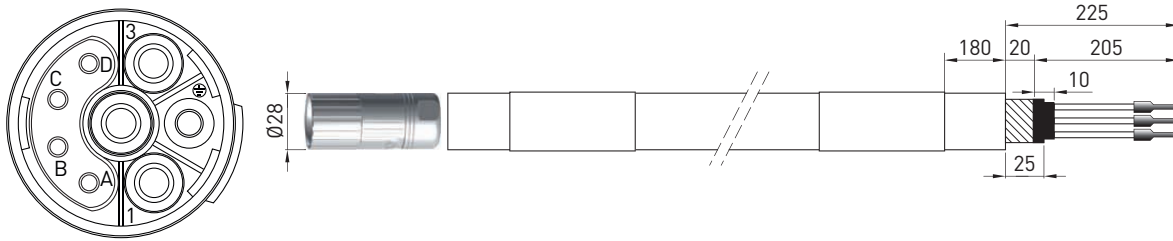

Table 6.17 Extension cables for motors LMSA, LMSC and LMFA (iron-core)

Article number	Designation	Cross-section	Plug	Length [m]
8-10-0069	Chainflex CF27.15.05.04.D	4 × 1.5 mm ² ; 4 × 0.5 mm ²	M23, 8-pin	3
8-10-0070				5
8-10-0071				8
8-10-0072				10
8-10-0074				15
8-10-0593	Chainflex CF27.25.05.04.D	4 × 2.5 mm ² ; 4 × 0.5 mm ²	M23, 8-pin	3
8-10-0594				5
8-10-0595				8
8-10-0596				10
8-10-0598				15
8-10-0946	Chainflex CF27.40.05.04.D	4 × 4.0 mm ² ; 4 × 0.5 mm ²	M23, 8-pin	3
8-10-0971				5
8-10-0972				8
8-10-0973				10
8-10-0947				15
8-10-0879	Chainflex CF27.40.05.04.D	4 × 4.0 mm ² ; 4 × 0.5 mm ²	M40, 8-pin	3
8-10-0880				5
8-10-0881				8
8-10-0882				10
8-10-0974				15

6.4.2 Extension cables for linear motors LMC

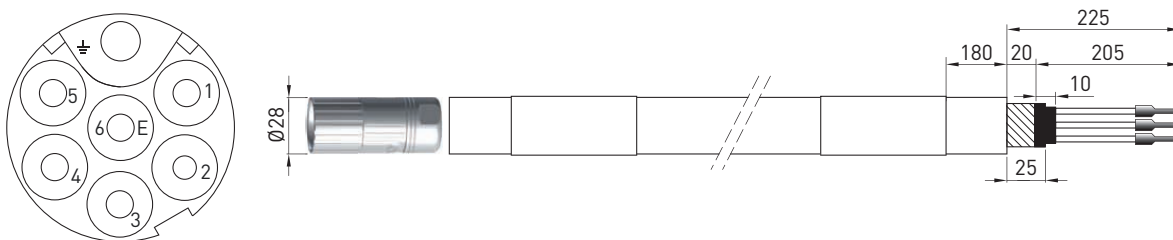

Table 6.18 Extension cables for motors LMC (ironless)

Article number	Designation	Cross-section	Length [m]
8-10-0258	Chainflex CF10.07.07	7 × 0.75 mm ²	3
8-10-0259			5
8-10-0260			8
8-10-0261			10
8-10-0263			15

Linear Motors & Distance Measuring Systems

Accessories

6.5 Motor connectors

6.5.1 Recommended motor connectors for iron-core linear motors

By default, the temperature sensor is continued via the motor extension cable, which is why the temperature sensor cable is attached to the motor connector. For continuous currents up to 30 A we recommend the M23 couplings and connectors, for continuous currents over 30 A the M40 couplings and connectors.

Table 6.19 Recommended motor connector for continuous currents up to 30 A for LMSA and LMFA motors

Coupling M23, 8-pin	Connector M23, 8-pin	Pin assignment
		
Article number: 8-10-0421	Article number: 8-10-0422	Coupling: connector-end view

Table 6.20 Recommended motor connector for continuous currents from 30 A for LMFA motors



Coupling M40, 8-pin	Connector M40, 8-pin	Pin assignment
		
Article number: 8-10-0507	Article number: 8-10-0508	Coupling: connector-end view

Table 6.21 Pin assignment of motor connector M23/M40, 8-pin

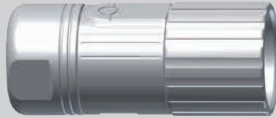
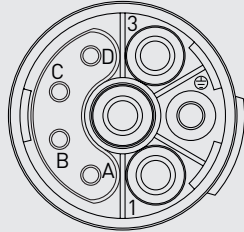
Motor cable	Pin no.	Signal	Function	Extension cable
Black-1	1	U	Motor phase	Black-1
Black-2	4	V	Motor phase	Black-2
Black-3	3	W	Motor phase	Black-3
LMFA				
Red	A	T+ ¹⁾	Thermal protection	Red
Yellow	B	T- ¹⁾	Thermal protection	Yellow
Black	C	T+ ²⁾	Thermal protection	Black
White	D	T- ²⁾	Thermal protection	White
LMSA				
Yellow	A	T+ ¹⁾	Thermal protection	Red
Green	B	T- ¹⁾	Thermal protection	Yellow
Brown	C	T+ ²⁾	Thermal protection	Black
White	D	T- ²⁾	Thermal protection	White

¹⁾ PTC temperature sensor

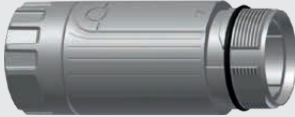
²⁾ PT1000/KTY84 temperature sensor

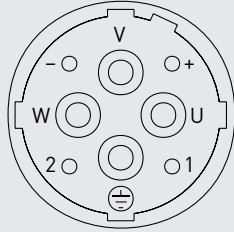
6.5.2 Recommended motor connectors for ironless linear motors

By default, the temperature sensor is continued via the motor extension cable, which is why the temperature sensor cable is attached to the motor connector.

Table 6.22 Recommended motor connector for LMC motors



Coupling M17, 7-pin	Connector M17, 7-pin	Pin assignment
		
Article number: 8-10-0437	Article number: 8-10-0433	Coupling: connector-end view

Table 6.23 Pin assignment of motor connector M17, 7-pin

Motor cable	Pin no.	Signal	Function	Extension cable
Brown	1	U	Motor phase	Black-1
White	4	V	Motor phase	Black-2
Grey	3	W	Motor phase	Black-3
Yellow	5	T+ ¹⁾	Thermal protection	Black-5
Green	6	T- ¹⁾	Thermal protection	Black-6
—	2	—	Not assigned	—
Green/Yellow	Protective earth/ground	—	GND	Green/Yellow

¹⁾ PTC temperature sensor

Linear Motors & Distance Measuring Systems

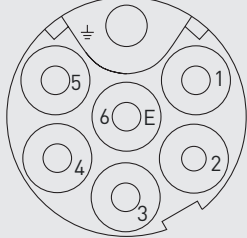
HIWIN MAGIC – magnetic distance measuring systems

7. HIWIN MAGIC – magnetic distance measuring systems

The magnetic distance measuring systems of the HIWIN MAGIC series are optimised for measuring the distances travelled in linear movements and particularly on linear motor axes. They are particularly suitable for use in harsh environmental conditions and are resistant to oil, dirt, vibrations and shocks.

The robust housing is electrically shielded, and signals are output in real time.

Two types are available:

- HIWIN MAGIC: type with separate encoder
- HIWIN MAGIC-PG: distance measuring system integrated in a linear guideway

Characteristics of MAGIC and MAGIC-PG

- Zero contact measurement with 1 V_{pp} or digital output
- Digital resolution of 1 µm
- Encoder and housing are resistant to dust, humidity, oil and chips
- Encoder with metal housing and IP67 protection class
- Simple assembly
- Signal output in real time
- Special housing for EMC optimization

7.1 HIWIN distance measuring systems

This distance measuring system consists of a separate encoder (Fig. 7.1) and a magnetic scale (Fig. 7.2). The customer can select suitable positions for both of these and install them. The measuring system HIWIN MAGIC is optimised for use on linear motor axes.

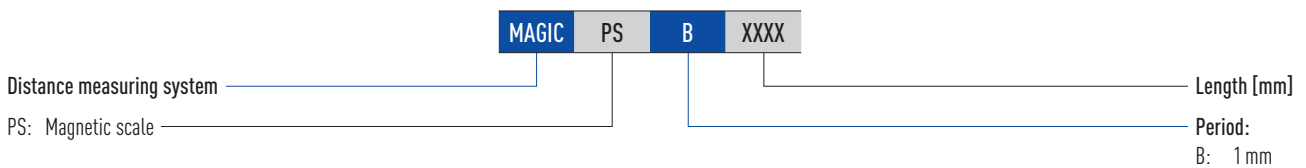

Fig. 7.1 MAGIC encoder

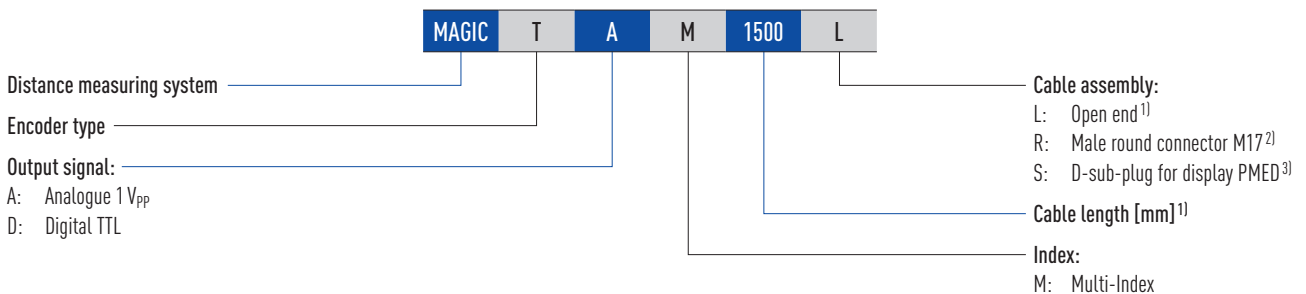

Fig. 7.2 MAGIC magnetic scale

7.1.1 Order code for magnetic scale of HIWIN MAGIC distance measuring system



7.1.2 Order code for encoder of HIWIN MAGIC distance measuring system



¹⁾ With open ends, the 1,000 cable length should be selected as standard (max. length: 5,000 mm)

²⁾ Suitable for the pre-assembled HIWIN extension cable, see Section 7.4.1

³⁾ The display has to be ordered separately

7.2 HIWIN MAGIC-PG distance measuring system

For this type, the distance measuring system is integrated in a linear guideway. The complete unit is referred to as a positioning guideway (PG). The encoder is fitted to a

standard block. It is suitable for HG_20, HG_25, QH_20, QH_25, CG_20 and CG_25. A magnetic scale is integrated directly in a profile rail (see Fig. 7.3 and Fig. 7.4).

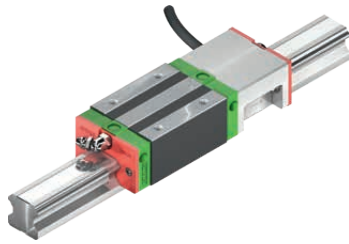

Fig. 7.3 MAGIC-PG system for HG and QH blocks

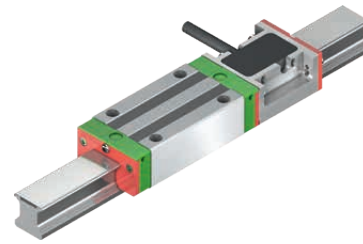
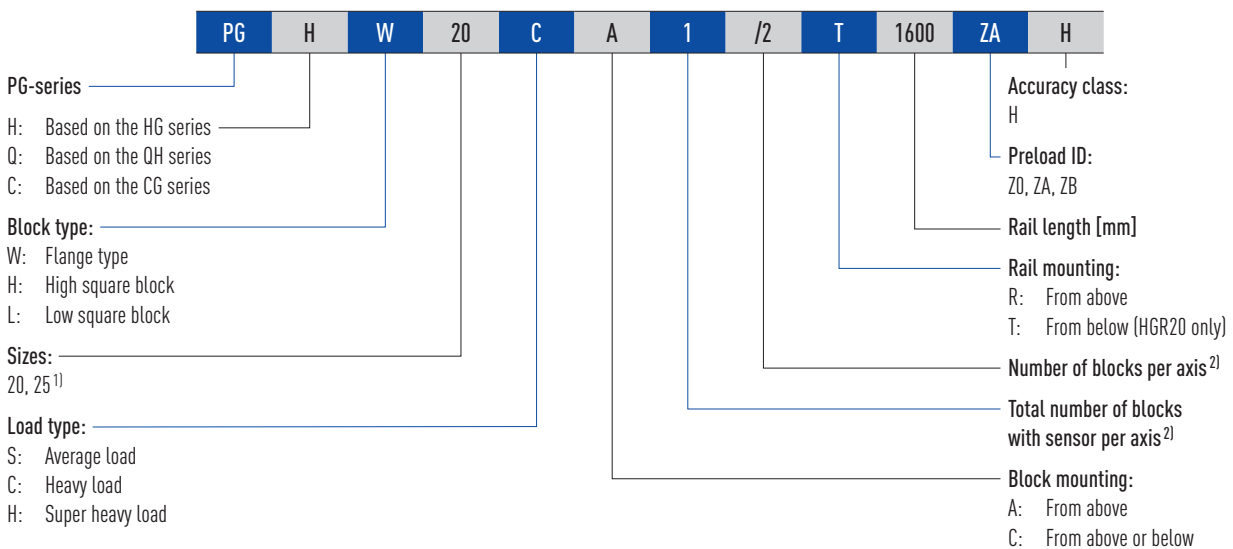
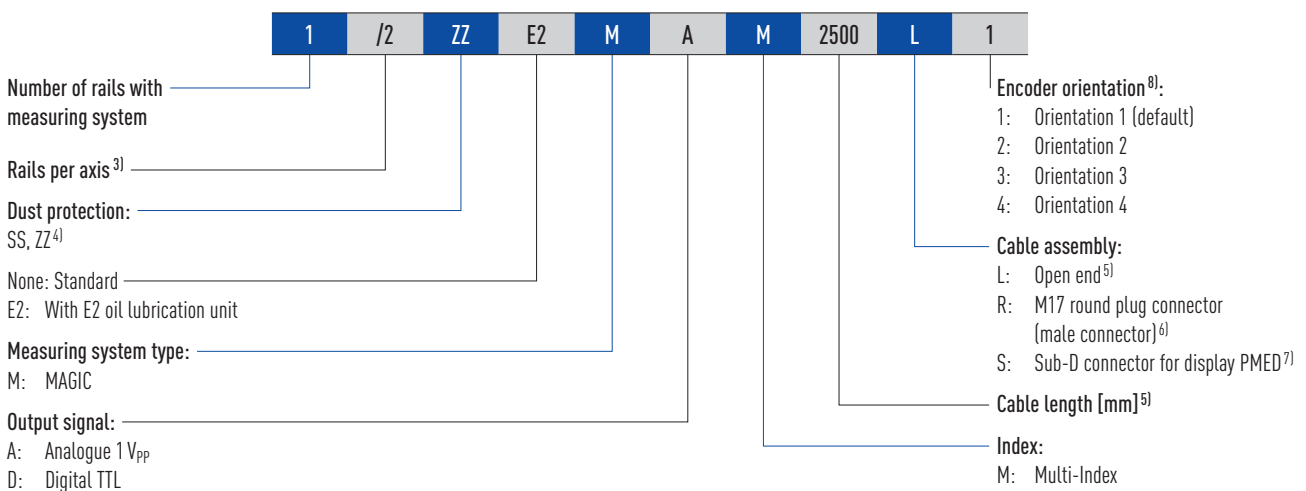

Fig. 7.4 MAGIC-PG system for CG blocks

7.2.1 Order code for HIWIN MAGIC-PG linear guideways



Continuation order code for HIWIN MAGIC-PG linear guideway:



¹⁾ PGH, PGQ: not identical to the standard rail HGR25R without groove. Mounting screw M5 instead of M6

²⁾ In the PG series, the total number of blocks per axis is specified (all blocks of the ordered article)

³⁾ The figure 2 is also a quantity, i.e. one item of the above-mentioned article consists of a pair of rails. No number is specified for individual rails

⁴⁾ If nothing is specified, the block will be supplied with standard dust protection (standard end seal and bottom seal)

⁵⁾ With open ends, the 1,000 cable length should be selected as standard (max. length PGH, PGQ: 5,000 mm; PGC: 1,000 mm)

⁶⁾ Suitable for the pre-assembled HIWIN extension cable, see Section 7.4.1

⁷⁾ The display has to be ordered separately

⁸⁾ See Section 7.3.1

Linear Motors & Distance Measuring Systems

HIWIN MAGIC – magnetic distance measuring systems

7.3 HIWIN MAGIC distance measuring systems: technical data

7.3.1 Orientation of the HIWIN MAGIC-PG encoder

According to the order code (Section 7.2.1) the HIWIN MAGIC-PG encoder is available the orientations 1 to 4. Without a statement about the required orientation the encoder is delivered by default (orientation 1).

For more than one block on a rail or on a rail pair, the encoder is assembled on block 1, rail 1, as shown in Fig. 7.5. If a non-standard orientation is needed, this has to be defined in the MAGIC-PG project planning sheet (www.hiwin.de).

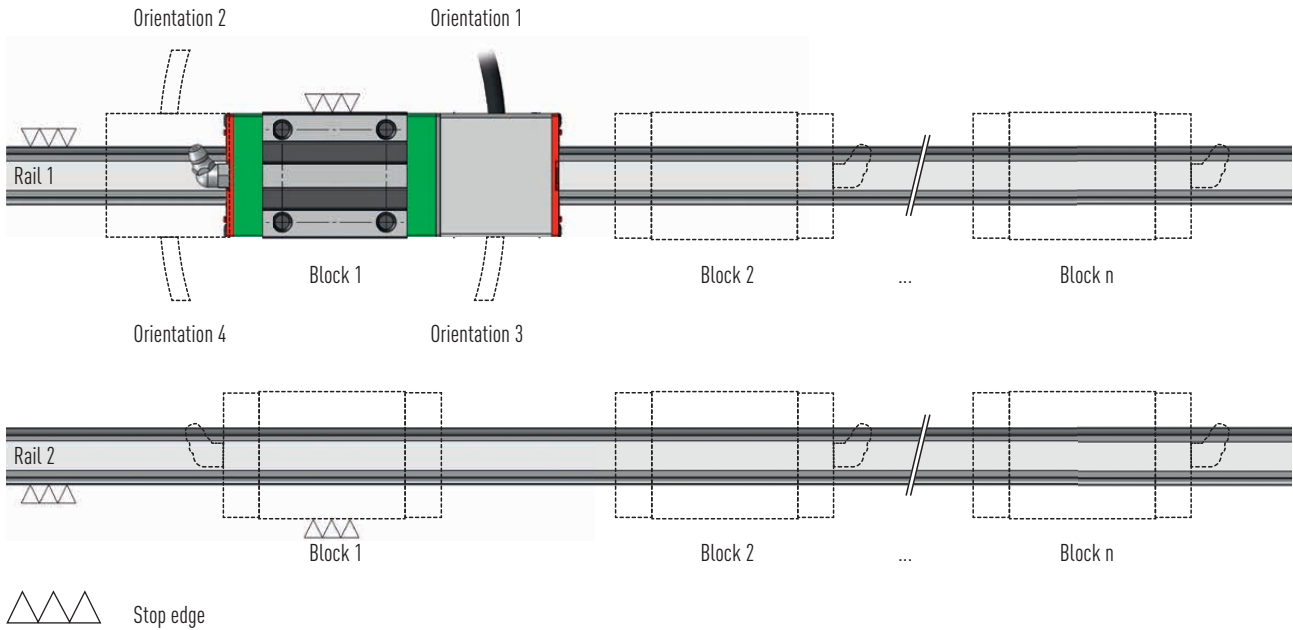

Fig. 7.5 Orientation of the HIWIN MAGIC-PG encoder

7.3.2 Dimensions

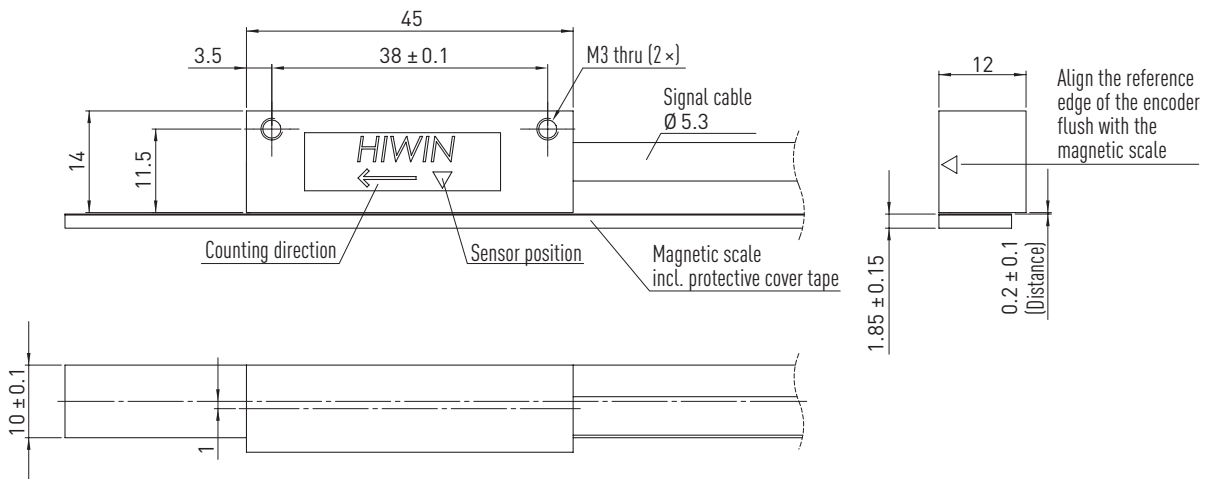

Fig. 7.6 Scale drawing of HIWIN MAGIC encoder

Unit: mm

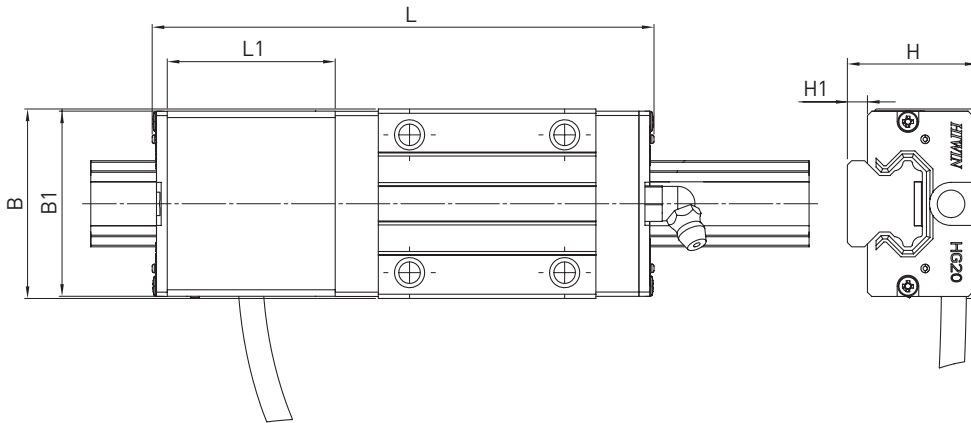

Fig. 7.7 Scale drawing of the HGH20CA block including the MAGIC-PG housing

Fig. 7.7 shows an HGH20CA/HGH25CA block. It is also possible to use the modules with HG_20, HG_25, QH_20, QH25, CG_20 and CG_25 block sizes (long type and flange type, see the "Linear Guideways" catalogue). The overall dimensions then change accordingly. The dimensions of all block sizes are shown in Table 7.1.

Table 7.1 Dimensions of the block including MAGIC-PG housing

Series/size	L [mm]	L1 [mm]	B [mm]	B1 [mm]	H [mm]	H1 [mm]
HG_20C	118.0	41.5	44	43.0	30	4.6
HG_20H	132.7	41.5	44	43.0	30	4.6
HG_25C	124.5	41.5	48	46.4	40	5.5
HG_25H	145.1	41.5	48	46.4	40	5.5
QH_20C	117.2	41.5	44	43.0	30	4.6
QH_20H	131.9	41.5	44	43.0	30	4.6
QH_25C	123.9	41.5	48	46.4	40	5.5
QH_25H	144.5	41.5	48	46.4	40	5.5
CG_20C	121.4	44.0	44	43.0	30	4.6
CG_20H	137.4	44.0	44	43.0	30	4.6
CG_25C	130.5	44.0	48	47.0	40	6.1
CG_25H	147.9	44.0	48	47.0	40	6.1

7.3.2.1 Dimensions of PG rail

Rail with groove, mounting from above (series HG/QH)

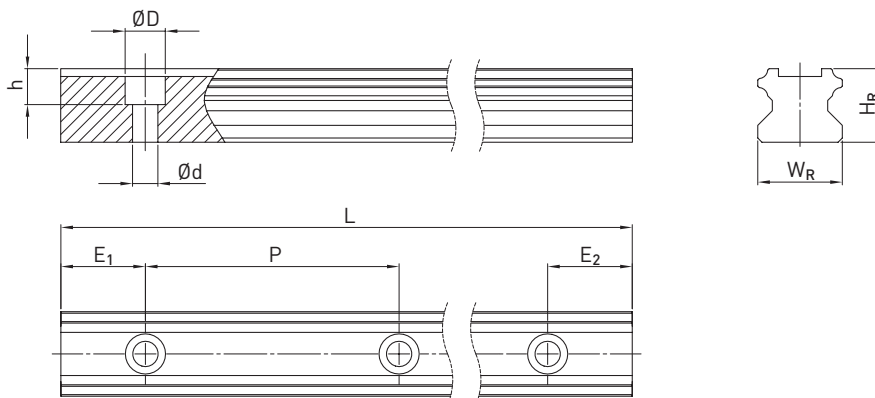

Linear Motors & Distance Measuring Systems

HIWIN MAGIC – magnetic distance measuring systems

Table 7.2 Dimensions HGR_R G1

Series/ Sizes	Mounting bolt for rail [mm]	Dimensions of rail [mm]						Max. length [mm]	Max. length $E_1 = E_2$ [mm]	$E_{1/2}$ min [mm]	$E_{1/2}$ max [mm]	Weight [kg/m]
		W_R	H_R	D	h	d	P					
HGR20R G1	M5 × 16	20	17.5	9.5	8.5	6.0	60	4,000	3,900	7	53	2.05
HGR25R G1C	M5 × 20	23	22.0	9.5	8.5	6.0	60	4,000	3,900	7	53	3.05

Rail with groove, mounting from below (series HG/QH)

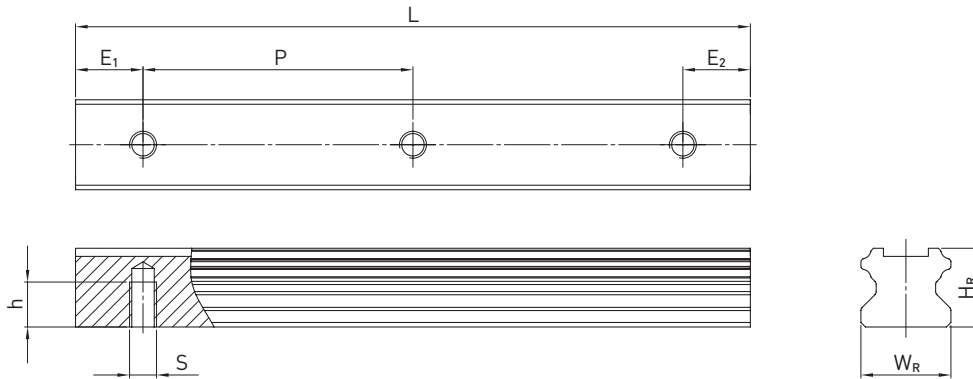

Table 7.3 Dimensions HGR_T G1

Series/ Size	Dimensions of rail [mm]					Max. length [mm]	Max. length $E_1 = E_2$ [mm]	$E_{1/2}$ min [mm]	$E_{1/2}$ max [mm]	Weight [kg/m]
	W_R	H_R	S	h	P					
HGR20T G1	20	17.5	M6	10	60	4,000	3,900	7	53	2.13

Rail with groove, mounting from above (series CG)

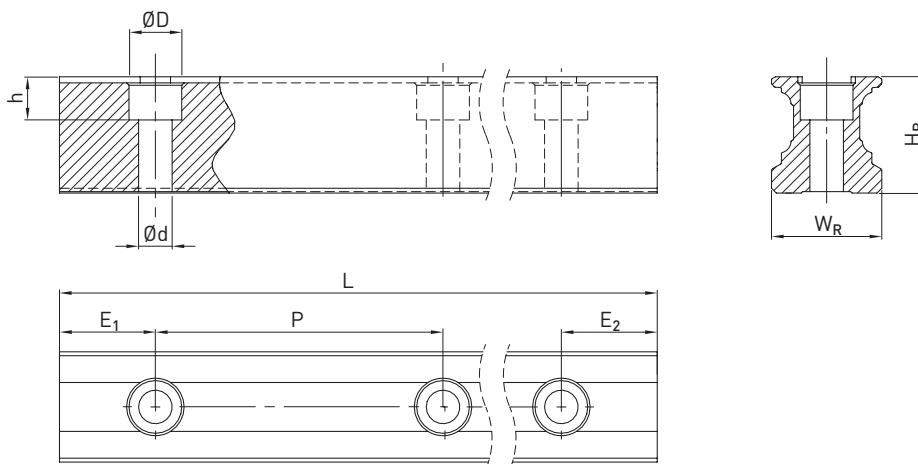

Table 7.4 Dimensions of CGR_R G1

Series/ size	Dimensions of rail [mm]						Max. length [mm]	Max. length $E_1 = E_2$ [mm]	$E_{1/2}$ min [mm]	$E_{1/2}$ max [mm]	Weight [kg/m]
	W_R	H_R	D	h	d	P					
CGR20R G1	20	20.55	9.5	8.5	6.0	60	4,000	3,900	7	53	2.05
CGR25R G1	23	24.25	11.0	9.0	7.0	60	4,000	3,900	8	52	3.05

7.3.3 Specifications of the distance measuring system HIWIN MAGIC and HIWIN MAGIC-PG

Table 7.5 Electrical and mechanical properties of HIWIN MAGIC and HIWIN MAGIC-PG

	1 V _{PP} (analogue)	TTL (digital)
Electrical properties		
Output signal specification	sin/cos, 1 V _{PP} (0.85 V _{PP} – 1.2 V _{PP})	Quadrature signal acc. to RS-422
Resolution	Infinite, signal period 1 mm	1 μm
Repeatability bidirectional	0.003 mm	0.002 mm
Absolute accuracy	± 20 μm/m	
Reference signal ¹⁾	Periodic index impulse at a distance of 1 mm	
Phase angle	90° ± 0.1° el	90°
DC component	2.5 V ± 0.3 V	—
Distortion factor	Typ. < 0.1 %	—
Operating voltage	5 V ± 5 %	
Power consumption	Typ. 35 mA, max. 70 mA	Typ. 70 mA, max. 120 mA
Max. measurement speed	10 m/s	5 m/s
EMC class	3, according to IEC 801	
Mechanical properties		
Housing material	Aluminium alloy, encoder bottom made of stainless steel	
Cable length ²⁾	PGH/PGQ: 5,000 mm; PGC: 1,000 mm	
Min. bending radius cable	40 mm	
Protection class	IP67	
Operating temperature	0 °C to +50 °C	
Weight of MAGIC encoder	80 g	
Weight of MAGIC-PG encoder	80 g	
MAGIC-PG suitable for blocks	HG_20, HG_25, QH_20, QH_25, CG_20, CG_25	

¹⁾ Can be used e.g. with reference switch

²⁾ For the use in energy chains we recommend our pre-assembled encoder cable with a pre-mounted round connector M17 (coupling, female) on one side, which matches the optional round plug connector M17 (male) of the encoder. For details, please contact your HIWIN technician.

Table 7.6 Properties of the magnetic scale

Properties	MAGIC-PG	MAGIC
Accuracy class ¹⁾	± 20 μm/m	
Linear expansion coefficient	11.5 × 10 ⁻⁶ m/K	
Period	1 mm	
Thickness magnetic scale	1.70 ± 0.10 mm	
Thickness magnetic scale with stainless steel protective cover tape	—	1.85 ± 0.15 mm
Width	10.05 ± 0.10 mm	
Maximum length	24 m	
Magnetic remanence	> 240 mT	
Pole pitch (distance north/south pole)	1 mm	
Single reference marks	Optional	
Material	Elastomers, nitrile and EPDM	
Temperature range	0 °C to +50 °C	
Weight	70 g/m	

¹⁾ at 20 °C

Linear Motors & Distance Measuring Systems

HIWIN MAGIC – magnetic distance measuring systems

7.4 Connection analogue and digital variant

7.4.1 Cable assignment (analogue and digital variant)

A high-quality, 8-core cable, each V1+, V1-, V2+, V2- and V0+, V0- (or A, \bar{A} , B, \bar{B} and Z, \bar{Z} for the digital variant), is used twisted in pairs.

In energy chains, we generally recommend our pre-assembled extension cables, which are designed especially for such use. The extension cables are supplied with a M17 round plug connector on one end (female coupling) or customised.

7.4.2 Formats and outputs

Signal format of sine/cosine 1 V_{pp} output (analogue)

Electrical signals after the differential input of the downstream electronic components. The sinus/cosinus 1 V_{pp} interface of HIWIN MAGIC-PG is strictly based on the Siemens specifications. The period length of the sinus output signal is 1 mm. The period length of the reference signal is 1 mm.

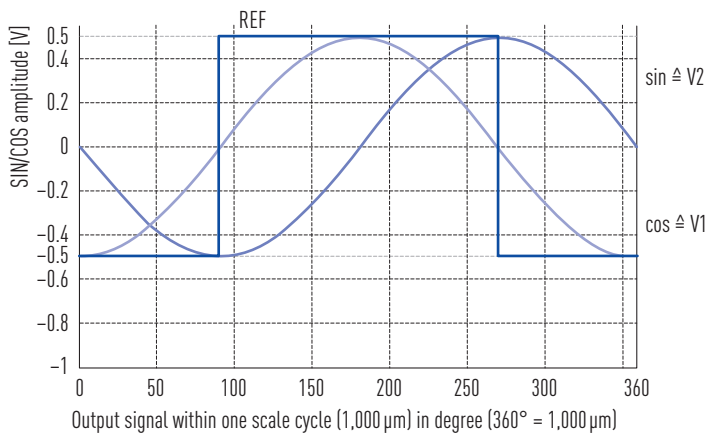

Fig. 7.8 Electrical signals after the differential input of the downstream electronic components (analogue version)

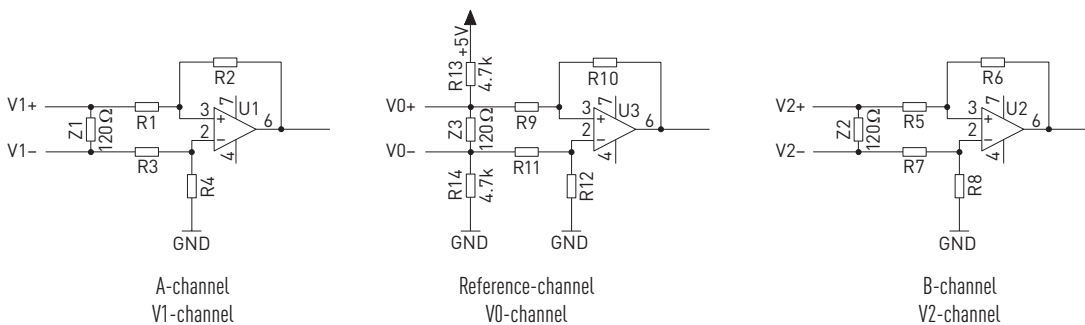

Fig. 7.9 Recommended switching of the subsequent electronic components for sin/cos 1 V_{pp} output

TTL-output (digital)

The signals on A and B channels have a 90° phase shift (according to RS-422 specification in DIN 66259). Recommended terminal resistance $Z = 120 \Omega$. Output signals: A, \bar{A} , B, \bar{B} and Z, \bar{Z} . Individual reference pulse (optional) and definition of a minimum pulse duration are possible as an option.

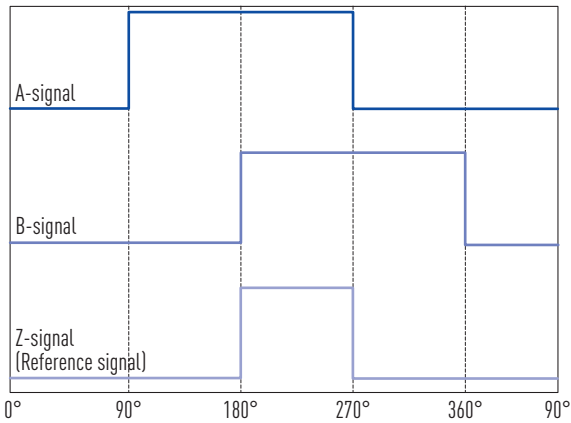

Fig. 7.10 Signals of the MAGIC encoder (TTL version)

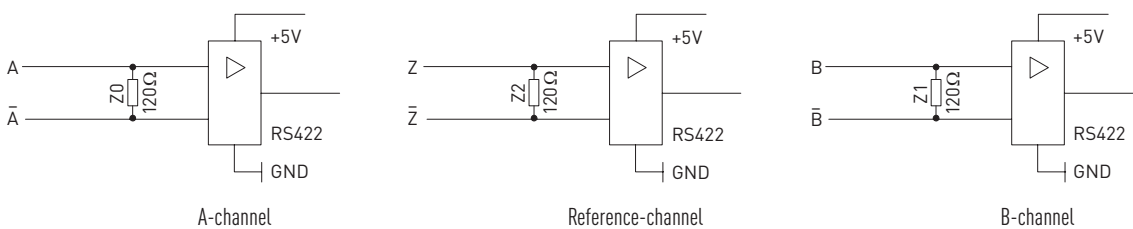

Fig. 7.11 Recommended switching of the subsequent electronic components for digital TTL output

7.5 PMED display

Combined with the distance measuring system HIWIN MAGIC or HIWIN MAGIC-PG the PMED display offers the possibility to display the current position of the encoder. In addition the display has 4 relay outputs and one RS-232 interface.

Features

- 8-digit LED display
- For analogue and digital input signal
- Easy handling
- Compact and robust design
- Simple assembly

Functions

- Flexible zero point adjustment
- Automatic zero point adjustment in the middle of a travel distance
- Absolute and relative counting function
- Units mm/inch
- 4 switchable relay outputs
- RS-232 interface



7.5.1 Order code for PMED display

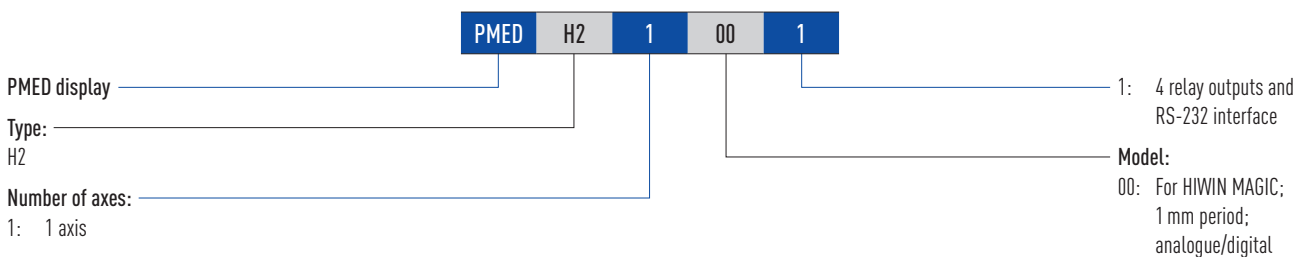

Linear Motors & Distance Measuring Systems

HIWIN MAGIC – magnetic distance measuring systems

7.5.2 Technical data of PMED display

7.5.2.1 Dimensions of PMED display

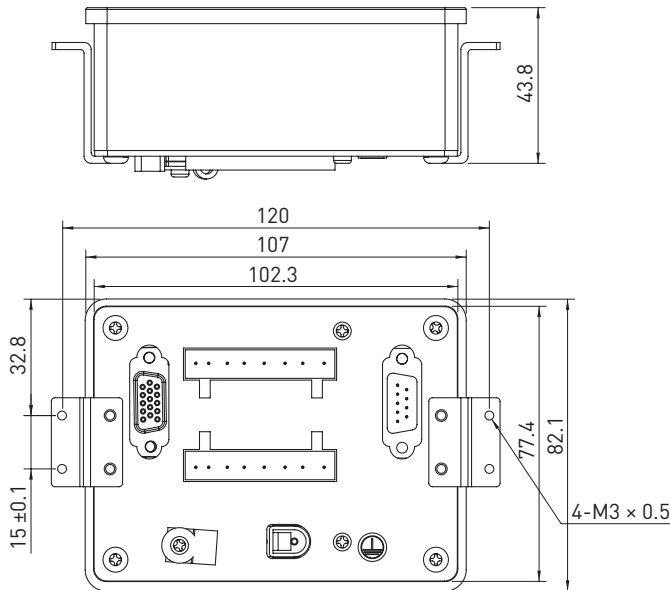

7.5.2.2 Inputs and outputs

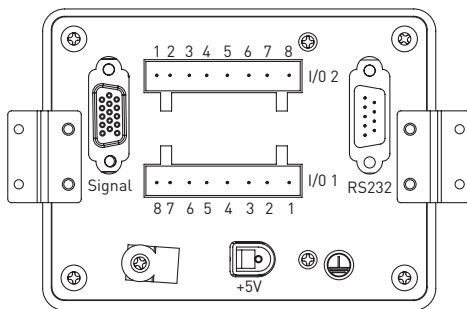

7.5.2.3 Signal input connector (HD Sub-D, 15 pin)

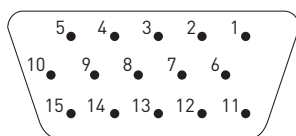

Table 7.7 Pin definition for signal input connector

Pin No.	Signal	Pin-No.	Signal	Pin No.	Signal
1	+5V	6	FG (housing shielding)	11	A+ (analogue)
2	GND	7	Z+ (reference track)	12	A- (analogue)
3	A+ (digital)	8	Z- (reference track)	13	B+ (analogue)
4	B+ (digital)	9	A- (digital)	14	B- (analogue)
5	Not assigned	10	B- (digital)	15	Not assigned

7.5.2.4 Signal output connector

Table 7.8 Pin definition for signal output connector

Relay output I/O 1		Relay output I/O 2	
Pin-No.	Signal	Pin-No.	Signal
1	Not assigned	1	Not assigned
2		2	
3	Not assigned	3	Not assigned
4		4	
5	Relay 0 (channel 0)	5	Relay 0 (channel 2)
6		6	
7	Relay 0 (channel 1)	7	Relay 0 (channel 3)
8		8	

7.6 Reference switch

To reference an axis the HIWIN reference switch can be placed at any position of the axis' travel range. The MAGIC and MAGIC-PG encoder delivers a periodic reference signal (index pulse, see Section 7.4.2). With a damped reference switch this signal can be used for the precise referencing of the axis.

7.6.1 Technical data of inductive reference switch

7.6.1.1 Dimensions of reference switch

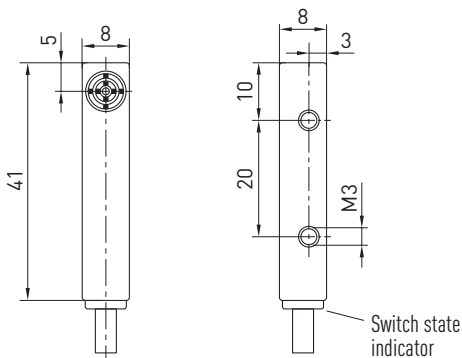

Linear Motors & Distance Measuring Systems

HIWIN MAGIC – magnetic distance measuring systems

Table 7.9 Reference switch specifications

Inductive	
Switching distance	2 mm
Correction factor V2A/brass/aluminium	1.16/0.70/0.67
Installation type	Flush
Switch hysteresis	< 10 %
Electrical	
Power supply	10 to 30 VDC
Power input (U _b = 24 V)	< 8 mA
Switching frequency	930 Hz
Temperature drift	< 10 %
Operating temperature	-25 to +80 °C
Voltage drop switch output	< 1 V
Switching current	100 mA
Residual current voltage drop	< 100 µA
Short circuit protection	Yes
Reverse polarity protection	Yes
Overload protection	Yes
Mechanical	
Housing material	Plastic
Full encapsulation	Yes
Protection mode	IP67
Connection type	Cable
Cable length	2 m/4 m
Protection class	III

7.6.1.2 Circuit diagram of the optional reference switch

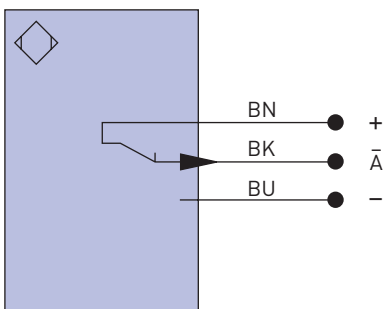

Explanation of symbols

- + Power supply „+“
- Power supply „0 V“
- \bar{A} Switch output/opener (NC)

Wire colours

- BN Brown
- BK Black
- BU Blue

We live motion.

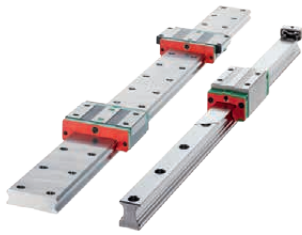

Linear Guideways



Ballscrews



Linear Axes

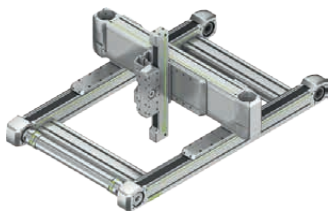

Linear Axis Systems



Torque Motors



Robots



Linear Motors



Rotary Tables



Drives & Servo Motors

Germany

HIWIN GmbH
Brücklesbünd 1
D-77654 Offenburg
Phone +49 (0) 7 81 9 32 78 - 0
Fax +49 (0) 7 81 9 32 78 - 90
info@hiwin.de
www.hiwin.de

Taiwan

Headquarters
HIWIN Technologies Corp.
No. 7, Jingke Road
Taichung Precision Machinery Park
Taichung 40852, Taiwan
Phone +886-4-2359-4510
Fax +886-4-2359-4420
business@hiwin.tw
www.hiwin.tw

Taiwan

Headquarters
HIWIN Mikrosystem Corp.
No. 6, Jingke Central Road
Taichung Precision Machinery Park
Taichung 40852, Taiwan
Phone +886-4-2355-0110
Fax +886-4-2355-0123
business@hiwinmikro.tw
www.hiwinmikro.tw

France

HIWIN GmbH
4, Impasse Joffre
F-67202 Wolfisheim
Phone +33 (0) 3 88 28 84 80
contact@hiwin.fr
www.hiwin.fr

Italy

HIWIN Srl
Via Pitagora 4
I-20861 Brugherio (MB)
Phone +39 039 287 61 68
Fax +39 039 287 43 73
info@hiwin.it
www.hiwin.it

Poland

HIWIN GmbH
ul. Puławska 405a
PL-02-801 Warszawa
Phone +48 22 544 07 07
Fax +48 22 544 07 08
info@hiwin.pl
www.hiwin.pl

Switzerland

HIWIN Schweiz GmbH
Eichwiesstrasse 20
CH-8645 Jona
Phone +41 (0) 55 225 00 25
Fax +41 (0) 55 225 00 20
info@hiwin.ch
www.hiwin.ch

Slovakia

HIWIN s.r.o., o.z.z.o.
Mládežnícka 2101
SK-01701 Považská Bystrica
Phone +421 424 43 47 77
Fax +421 424 26 23 06
info@hiwin.sk
www.hiwin.sk

Czech Republic

HIWIN s.r.o.
Medkova 888/11
CZ-62700 Brno
Phone +42 05 48 528 238
Fax +42 05 48 220 223
info@hiwin.cz
www.hiwin.cz

Netherlands

HIWIN GmbH
info@hiwin.nl
www.hiwin.nl

Austria

HIWIN GmbH
info@hiwin.at
www.hiwin.at

Romania

HIWIN Srl
info@hiwin.ro
www.hiwin.ro

Slovenia

HIWIN Srl
info@hiwin.si
www.hiwin.si

Hungary

HIWIN GmbH
info@hiwin.hu
www.hiwin.hu

Denmark

HIWIN GmbH
info@hiwin.dk
www.hiwin.dk

China

HIWIN Corp.
www.hiwin.cn

Japan

HIWIN Corp.
info@hiwin.co.jp
www.hiwin.co.jp

USA

HIWIN Corp.
info@hiwin.com
www.hiwin.com

Korea

HIWIN Corp.
www.hiwin.kr

Singapore

HIWIN Corp.
www.hiwin.sg