

Support Unit

Technical Information





Semiconductor Subsystem

- Semiconductor/LED/Panel
- EFEM (Equipment Front End Module)
 - Wafer Robot
 - Load Port
 - Wafer Aligner



Multi-Axis Robot

- Pick-and-Place / Assembly / Array and Packaging / Semiconductor / Electro-Optical Industry / Automotive Industry / Food Industry
- Articulated Robot
 - SCARA Robot
 - Electric Gripper
 - Integrated Electric Gripper



Single-Axis Robot

- Precision / Semiconductor / Medical / FPD
- KK, SK
 - KS, KA
 - KU, KE, KC



Torque Motor Rotary Table

- Medical / Automotive Industry / Machine Tools / Machinery Industry
- RAB Series
 - RAS Series
 - RCV Series
 - RCH Series



Ball screw

- Precision Ground / Rolled
- Super S Series
 - Super T Series
 - Mini Roller
 - Ecological & Economical Lubrication Module E2
 - Rotating Nut (R1)
 - Energy-Saving & Thermal-Controlling (Cool Type)
 - Heavy Load Series (RD)
 - Ball Spline



Linear Guideway

- Automation / Semiconductor / Medical
- Ball Type--HG, EG, WE, MG, CG
 - Quiet Type--QH, QE, QW, QR
 - Other--RG, E2, PG, SE, RC



Bearing

- Machine Tools / Robot
- Crossed Roller Bearing
 - Ballscrew Bearing
 - Support Unit



DATORKER® Strain Wave Gear

- Robot / Automation Equipment / Semiconductor Equipment / Machine Tools
- DSC Type
 - DSH Type
 - DGC Type
 - DGH Type
 - DLC Type



AC Servo Motor & Drive

- Semiconductor / Packaging Machine / SMT / Food Industry / LCD
- Drives--D1, D2T/D2T-LM, E1
 - Motors--FR, E1



Medical Equipment

- Hospital / Rehabilitation Centers / Nursing Homes
- Robotic Gait Training System
 - Robotic Endoscope Holder



Linear Motor Stage

- Automated Transport / AOI Application / Precision / Semiconductor
- Iron-core Linear Motor
 - Coreless Linear Motor
 - Linear Turbo Motor LMT
 - Planar Servo Motor
 - Air Bearing Platform
 - X-Y Stage • Gantry Systems
 - Single-Axis Linear Motor Stage



Torque Motor & Direct Drive Motor

- Machine Tools
- Torque Motor--TM-2/IM-2, TMRW Series
- Inspection / Testing Equipment / Robot
- Direct Drive Motor--DMS, DMY, DMN, DMT Series

Content

1. Feature	1
2. Characteristic	1
3. Standard Support Unit	2
3.1 Standard Support Unit introduction	2
3.2 Specification code	2
3.3 Structure chart	3
3.4 Purchasing guide	4
3.5 Precision	5
4. Heavy Load Support Unit	6
4.1 Introduction	6
4.2 Specification	6
4.3 Type	6
4.4 Heavy Load Support Unit composition	7
4.5 Dimensions for Heavy Load Support Unit	8
5. Shaft Diameters Available for Support Unit	9
6. Standard Tighten Torque	9
7. Mounting Procedure	10
7.1 Installing the Support Unit	10
7.2 Installation onto the Table and the Base	10
7.3 Checking the Accuracy and Fastening the Screw	11
7.4 Connecting to the Motor	11
8. Product Specification	12
8.1 Standard Support Unit Specification	12
8.1.1 AK Series	12
8.1.2 AF Series	13
8.1.3 BK Series	14
8.1.4 BF Series	15
8.1.5 EK Series	16
8.1.6 EF Series	17
8.1.7 FK Series	18
8.1.8 FF Series	19
8.1.9 LK Series	20
8.1.10 LF Series	21
8.1.11 LFA Series	22
8.1.12 Suggestive machining dimension for support units.....	23
• Fixed Side-BK Series	23
• Fixed Side-FK, EK, AK, LK Series	24
• Supported Side	25
8.1.13 Standard Lock Nut	26
8.2 Heavy Load Support Unit Specification	27
8.2.1 WBK Series	27
8.2.2 Heavy Load Lock Nut	29

1. Feature

HIWIN support units are composed of a bearing housing, bearing, holding lid, seal, lock nut and set screws. The support units can be used on fixed and supported ends of the ballscrew, which mounts the ballscrew in the desired position. Its compact size is easy to install, especially in the narrowed space. Since the bearings are greased and adjusted to the suitable position, there is no need for additional alignment or installation processes, which reduces installation time and maintenance.

HIWIN support units can be applied to automation and industrial machinery, and are classified into 11 types: AK, AF, BK, BF, EK, EF, FK, FF, LK, LF and LFA. For the machinery structures requiring higher axial thrust force, HIWIN recommends the WBK support unit series. The WBK is used for high load applications and better axial stiffness, which allows a machinery structure to hold accurate positioning under a heavy load. Currently the heavy load support units are classified into 3 assembly types, each offering different loading capabilities: DF, DFD, and DFF.

2. Characteristic

- Assembled with high accuracy and stiff angular bearings
- Anti-rust surface
- Compact size and easy installation in tight or narrow spaces
- Instant installation without additional processes
- Multiple sizes and types available
- Total solution- Available to ship with a HIWIN ballscrew assembly

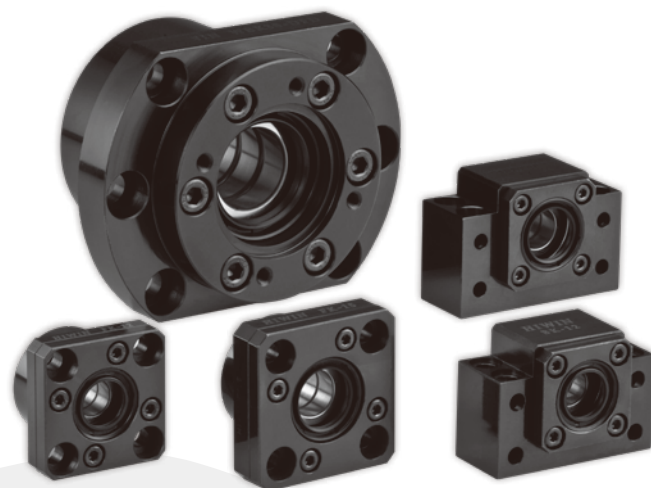

3. Standard Support Unit

3.1 Standard Support Unit introduction

Generally standard support units are applied in automation and industrial machinery. The support units can be classified into 2 types: fixed-end(AK, BK, EK, FK, LK), and supported-end(AF, BF, EF, FF, LF, LFA).

Ballscrews are the best choice to acquire a better transmission efficiency. Though ACME screws or similar sliding friction screws have worse machinery efficiency and waste more resources, standard support units can still be used to fix and support.

3.2 Specification code

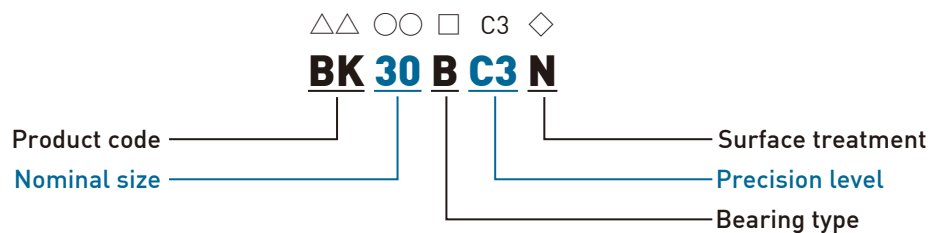

1. △△ : 11 Product codes can be classified as fixed-end AK, BK, EK, FK, LK and supported-end AF, BF, EF, FF, LF, LFA
2. ○○ : Nominal size of bearing bore. There are 2 digits and the units are in millimeters (mm). e.g. 30 refers to diameter 30mm, and 35 means diameter 35 mm. The nominal diameter of the supported-end refers to the nominal diameter opposite to the fixed-end; the inner diameter of the supported end is equal to or smaller than the nominal diameter.
3. □ : Bearing type. Blank refers to standard production which uses a 30 degree angular contact bearing. On shaft diameters over 20mm, a 40 degree angular contact bearing is available. Nominal diameters of 35mm and 40mm require higher radial loading and are only offered with the 40 degree angular contact bearing.
4. C3 : There are 3 precision classes C3, C5 and C7. It is suggested to use C3 support units with a C3 ballscrew, and C5 ballscrew can be used with C3 or C5 support units, which enables the support units precision to match the ballscrews precision. C7 ballscrews should only be used with C7 support units.
5. ◇ : There are 2 types of surface treatments available: blackening and nickel plating. Blank refers to blackening which is HIWIN standard. N refers to nickel plating, which is manufactured by order.

3.3 Structure chart

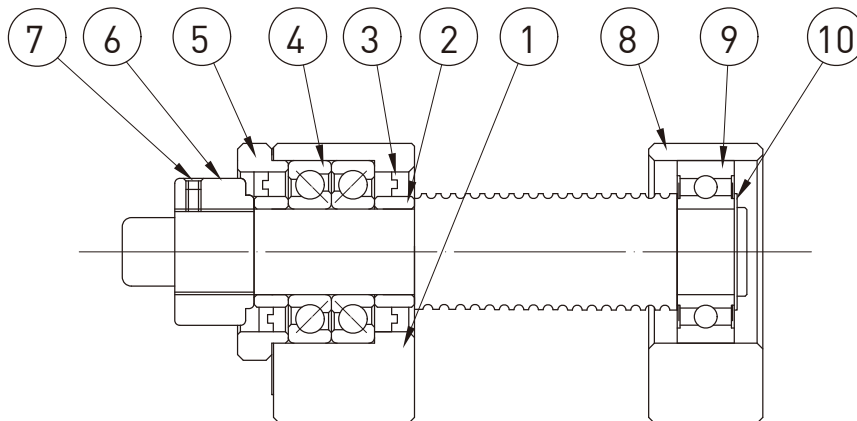

Item	Description
1	Bearing housing of fixed end
2	Collar
3	Seal
4	Angular contact ball bearing
5	Holding lid
6	Lock nut
7	Hexagonal socket-head setscrew with set piece
8	Bearing housing of supported end
9	Deep groove ball bearing
10	Snap ring

Note: 1. Do not disassemble Item 1, 3-5 as they are installed and adjusted well, or the precision may be affected.

2. Standard bearing is pre-packed with #2 Li/Ca soap grease, any special requirement please contact HIWIN.

3.4 Purchasing guide

Fixed Side								
Internal Diameter (mm)	Type					Bearing	Axial Direction	
	BK	LK	FK	EK	AK		Load Limit (kN)	Basic Dynamic Load Rating Ca (kN)
Φ 6	-	-	FK06	EK06	-	706A	0.73	2.4
Φ 8	-	LK08	FK08	EK08	-	708A	1	4
Φ 10	BK10	LK10	FK10	EK10	AK10	7000A	1.9	6.4
Φ 12	BK12	LK12	FK12	EK12	AK12	7001A	2.1	6.9
Φ 15	BK15	LK15	FK15	EK15	AK15	7002A	2.4	7.3
Φ 17	BK17	-	FK17	-	-	7203A	4.1	12.9
Φ 20	BK20	-	-	-	-	7004A	4.2	12.9
Φ 20	-	-	FK20	EK20	AK20	7204A	5.8	17.2
Φ 20	-	-	FK20B	EK20B	AK20B	7204B	6.8	18.3
Φ 25	BK25	-	FK25	-	AK25	7205A	7	19.3
Φ 25	BK25B	-	FK25B	-	AK25B	7205B	8	20.3
Φ 30	BK30	-	FK30	-	-	7206A	9.8	26.8
Φ 30	BK30B	-	FK30B	-	-	7206B	10.5	28.4
Φ 35	BK35	-	-	-	-	7207B	14.4	37.3
Φ 40	BK40	-	-	-	-	7208B	18	44

Note: 1. P5 bearing is used in C3 and C5 support unit; P0 bearing is used in C7 support unit.

2. Applied in light resultant axial force.

Supported Side									
Internal Diameter (mm)	Type						Bearing	Radial Direction	
	BF	LF	LFA	FF	EF	AF		Basic Dynamic Load Rating C (kN)	Basic Static Load Rating C0 (kN)
Φ 5	-	-	-	FK05(C7)	EK05(C7)	-	605	1.3	0.5
Φ 6	-	LF08	-	FF06	EF06 EF08	-	606ZZ	2.2	0.8
Φ 8	BF10	-	-	FF10	EF10	AF10	608ZZ	3.3	1.3
Φ 10	BF12	LF12	-	FF12	EF12	AF12	6000ZZ	4.5	1.9
Φ 12	-	-	LFA12	-	-	-	6801ZZ	1.9	1
Φ 15	BF15	LF15	-	FF15	EF15	AF15	6002ZZ	5.6	2.8
Φ 15	-	-	LFA15	-	-	-	6902ZZ	4.3	2.2
Φ 17	BF17	-	-	FF17	-	-	6203ZZ	9.5	4.8
Φ 20	BF20	-	-	-	-	-	6004ZZ	9.4	5
Φ 20	-	-	-	FF20	EF20	AF20	6204ZZ	12.8	6.6
Φ 20	-	-	LFA20	-	-	-	6804ZZ	4	2.4
Φ 25	-	-	LFA25	-	-	-	6005ZZ	10.1	5.8
Φ 25	BF25	-	-	FF25	-	AF25	6205ZZ	14	7.8
Φ 30	BF30	-	-	FF30	-	-	6206ZZ	19.5	11.3
Φ 35	BF35	-	-	-	-	-	6207ZZ	25.7	15.3
Φ 40	BF40	-	-	-	-	-	6208ZZ	29.1	17.9

3.5 Precision

Support unit C3, C5, C7 requires different precision level. The fixed-end support unit uses 30 or 40 degree angular contact bearings, and the supported –end unit uses a deep-groove bearing of series 6.

C3 fixed-end support units utilize a P5 bearing and uses a DF type bearing assembly. There's preload between 2 bearings to avoid movement of the ballscrew and backlash from the machine. C3 fixed and supported-end support units enable the shaft and the supports to maintain good turning precision after assembly due to the precise geometrical tolerances between the datum plane and the bearing.

C5 support units are also provided with P5 bearings, and uses the DF type bearing assembly. There's preload between 2 bearings to avoid movement of the ballscrew and backlash from the machine.

C7 support units are provided with P0 bearings, and there may or may not be preload between the 2 bearings which can result in varying backlash values per support unit, but due to the DF bearing assembly type, it can support the axial force of the shaft to avoid large movements while the shaft is enforced.

Moreover, the different support units will have different tolerances from standard side to the center, illustrated as below:

Support Unit Level	Applied Ball Screw	Bearing Level	Bearing Preload	Distance Tolerance (b) (mm)	Height Tolerance (h) (mm)	Shaft Tolerance (ØD) (mm)
C3	C3	P5	Preloaded	±0.015	±0.01	g6
C5	C5 or C7	P5	Preloaded	±0.02	±0.02	g6
C7	C7	P0	N/A	±0.04	±0.03	g8

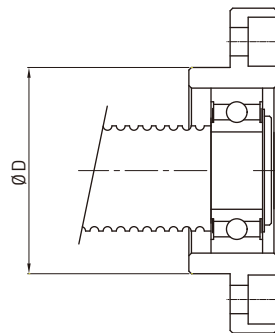
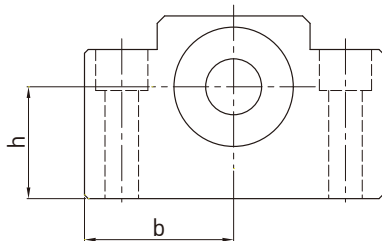

Height Tolerance: Refers to the tolerance of h.

Distance Tolerance: Refers to the tolerance of b.

Unit : μm

Shaft Diameter (mm)		Housing Outer Diameter Tolerance			
		g6		g8	
high	low	high	low	high	low
18	30	-7	-20	-7	-40
30	50	-9	-25	-9	-48
50	80	-10	-29	-10	-56
80	120	-12	-34	-12	-66

4. Heavy Load Support Unit

4.1 Introduction

Heavy Load Bearing Supports have excellent axial loading capabilities and can be applied in a wide range of industrial machines. The WBK utilizes 60-degree angular contact bearings, it handles higher axial load and high stiffness.

Rotation precision grade is P4 to meet positioning accuracy.

The heavy load bearing supports have three configuration types: DF, DFD, and DFF. DF is for general use and can bear both normal and opposite axial forces. DFD uses one bearing on one side and two on the opposite side, to enhance the loading capacity. DFF uses two bearings in both directions to increase each sides loading capacity. Customers can choose from different configuration types based on the axial loading capabilities needed for the application.

4.2 Specification

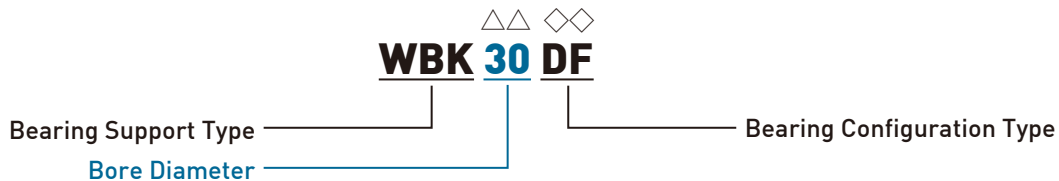

WBK : Bearing Support Type. WBK is the heavy load support unit for ballscrews.

△△ : Bore diameter in millimeters (mm). Ex. 30 indicates a bore diameter of 30mm.

◇◇ : Bearing Configuration Type. There are three types which are DF, DFD, and DFF.

4.3 Type

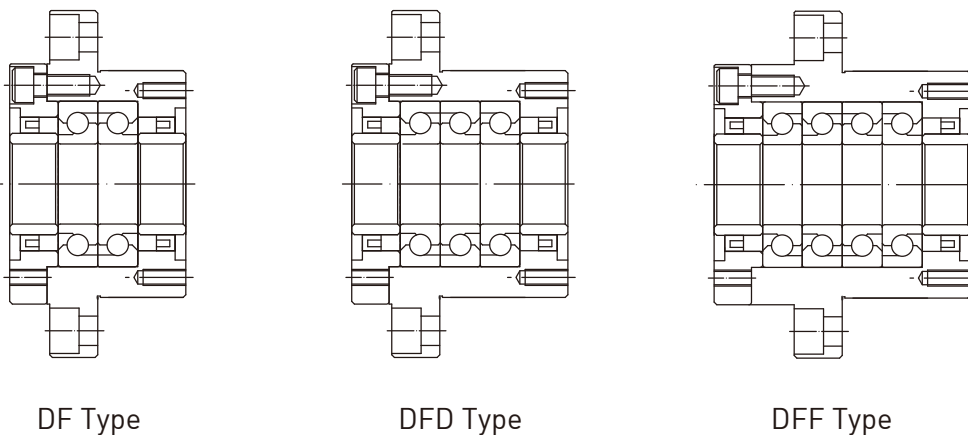

Note: Please contact HIWIN if the other combination types, like DB, are needed.

4.4 Heavy Load Support Unit composition

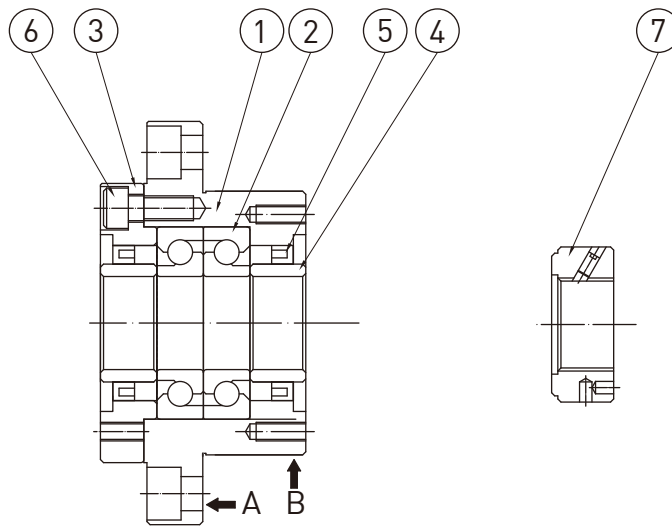

Number	Item	Quantity
1	Bearing housing	1
2	Bearing	1 set
3	Holding lid	1
4	Collar	2
5	Seal	2
6	Set Screw	6 or 8
7	Lock Nut	1

Note:1. Please use plane A and B as the datum plane while installing the support unit.

2. Please DO NOT disassemble items 1, 2, 3, 5 to avoid affecting accuracy.

3. Lubrication #2 Li/Ca soap grease is applied, please contact HIWIN engineers when special modifications are needed.

4.5 Dimensions for Heavy Load Support Unit

Bore Dia. (mm)	Spec.	Basic Axial Dynamic Load (kN)	Permissible Axial Load (kN)		Preload (kN)	Rigidity (N/ μm)	Max Torque (N/m)
			Normal	Opposite			
Φ 15	WBK 15 DF	21.9	26.6	26.6	2.15	750	0.19
Φ 17	WBK 17 DF	21.9	26.6	26.6	2.15	750	0.19
Φ 20	WBK 20 DF	21.9	26.6	26.6	2.15	750	0.19
Φ 25	WBK 25 DF	28.5	40.5	40.5	3.15	1000	0.29
	WBK 25 DFD	46.5	81.5	40.5	4.3	1470	0.39
	WBK 25 DFF	46.5	81.5	81.5	6.3	1960	0.49
Φ 30	WBK 30 DF	29.2	43	43	3.35	1030	0.3
	WBK 30 DFD	47.5	86	43	4.5	1520	0.4
	WBK 30 DFF	47.5	86	86	6.7	2010	0.5
Φ 35	WBK 35 DF	31	50	50	3.8	1180	0.34
	WBK 35 DFD	50.5	100	50	5.2	1710	0.45
	WBK 35 DFF	50.5	100	100	7.65	2350	0.59
Φ 40	WBK 40 DF	31.5	52	52	3.9	1230	0.36
	WBK 40 DFD	51.5	104	52	5.3	1810	0.47
	WBK 40 DFF	51.5	104	104	7.85	2400	0.61

Note: 1. 60° contact angle Ballscrew Bearings are adopted.

2. Surface blackening treatment. Please contact us when other surface treatments are needed.

5. Shaft Diameters Available for Support Unit

Ball screw Dia.(mm)	Bearing Support Spec.											
	Fixed Side						Supported Side					
	BK	AK	EK	FK	LK	WBK	BF	AF	EF	FF	LF	LFA
Φ 8	-	-	EK06	FK06	-	-	-	-	EF06	FF06	-	-
Φ 10~Φ 12	-	-	EK08	FK08	LK08	-	-	-	EF08	FF06	LF08	LFA 12
Φ 10~Φ 15	BK10	AK10	EK10	FK10	LK10	-	BF10	AF10	EF10	FF10	LF12	LFA 15
Φ 14~Φ 18	BK12	AK12	EK12	FK12	LK12	-	BF12	AF12	EF12	FF12	LF12	LFA 15
Φ 20	BK15	AK15	EK15	FK15	LK15	WBK 15	BF15	AF15	EF15	FF15	LF15	LFA 20
Φ 25~Φ 28	BK17	-	-	FK17	-	WBK 17	BF17	-	-	FF17	-	-
	BK20	AK20	EK20	FK20	-	WBK 20	BF20	AF20	EF20	FF20	-	LFA 25
Φ 30~Φ 36	BK25	AK25	-	FK25	-	WBK 25	BF25	AF25	-	FF25	-	
Φ 40	BK30	-	-	FK30	-	WBK 30	BF30	-	-	FF30	-	
Φ 45	BK35	-	-	-	-	WBK 35	BF35	-	-	-	-	
Φ 50	BK40	-	-	-	-	WBK 40	BF40	-	-	-	-	

6. Standard Tighten Torque

Standard Tighten Torque			
Bolt Spec.	Bolt-Sectional Pitch (mm ²)	Standard Operating Torque (N-m)	Standard Axial Tension (kN)
M3	5.03	0.63	1.1
M4	8.78	1.5	1.9
M5	14.2	3	3.0
M6	20.1	5.2	4.3
M8	36.6	12.5	7.8
M10	58	24.5	12.3
M12	84.3	42	17.5
M16	157	106	33.2

Note: Standard bolt stress: 210 (N/mm²)

7. Mounting Procedure

7.1 Installing the Support Unit

Install the fixed-end support unit and collar onto the ballscrew shaft, then use a wrench to slightly fix the lock nut.

Notes: (1) Do not disassemble the bearing support.

(2) When inserting the screw shaft to the Support Unit, please be careful not to scrape the seal lip.

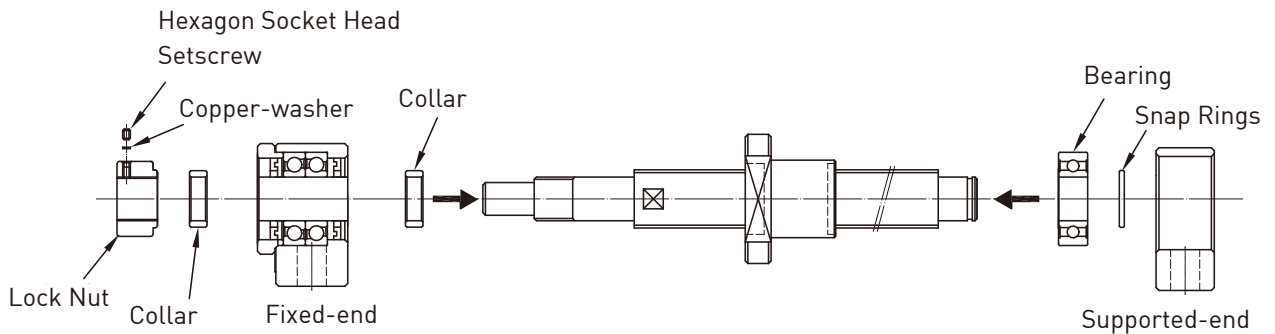

7.2 Installation onto the Table and the Base

1. When mounting the ballnut to the table, insert the nut into the bracket and temporarily fasten it.
2. Mount the bearing onto the ball screw shaft and fix it with the snap ring, and then put into the supported-end support unit.
3. Temporarily fasten the fixed-end and supported-end Support Unit to the base.

Move the table toward the fixed-end Support Unit to align the axial center.

Adjust the position of each part until the nut can move smoothly, then lock the support unit tightly onto the base temporarily.

- ① Using the fixed-end Support Unit as the reference point: please design a clearance between the table or inside the bracket and ball screw nut for adjusting the height of ball screw shaft and nut.
- ② Using the table as the reference point:
 - Square type Support Unit – adjust by using a shim.
 - Round type Support Unit – Be careful of the clearance between the outer surface of the nut and the inner surface of the mounting section.

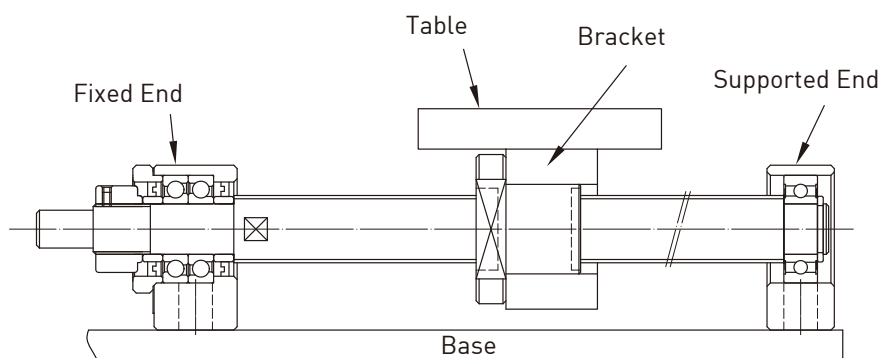

7.3 Checking the Accuracy and Fastening the Screw

1. Measure and adjust the accuracy of the fixed-end and use a wrench to lock the lock nut completely. Then secure the lock nut in place by tightening the Hexagonal socket-head setscrews.
2. Press the copper-washer with hexagonal set screw, please glue adhesive on it and then fully lock by wrench to prevent it from loosening. In addition, if the support units are being used under harsh conditions; Please contact HIWIN for details on preventing other parts from loosening.
3. Once properly aligned, use a wrench to lock the bolts of the fixed-end support unit, the bolts for the ballnut and the bolts of the supported-end support unit.

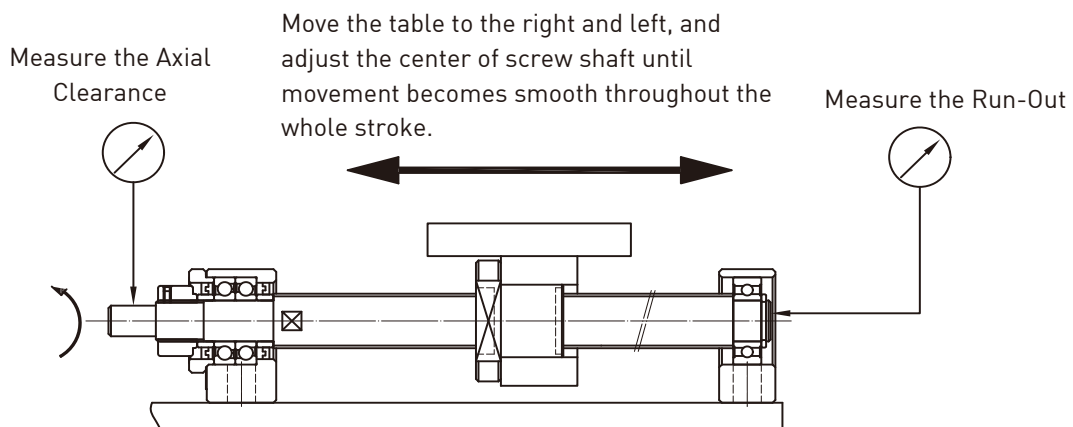

7.4 Connecting to the Motor

1. Fix the motor to the machine.
2. Connect the ballscrew to the motor using a motor coupling.
3. Test the motor operation after installation.

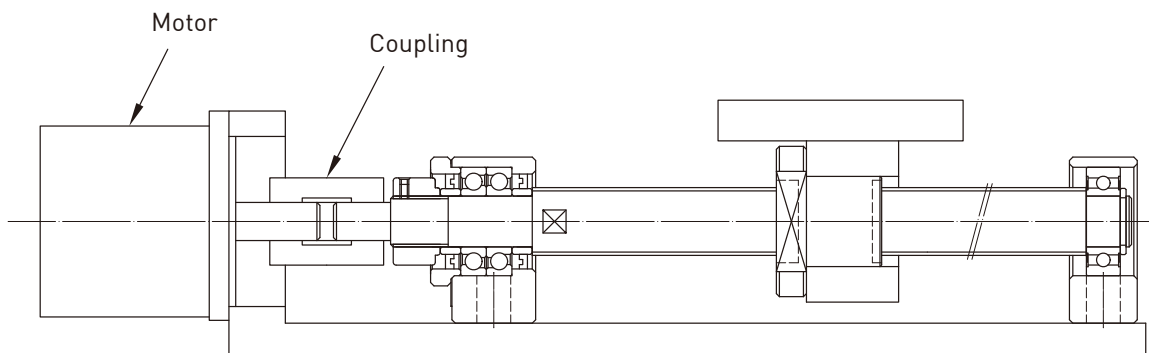

8. Product Specification

8.1 Standard Support Unit Specification

8.1.1 AK Series

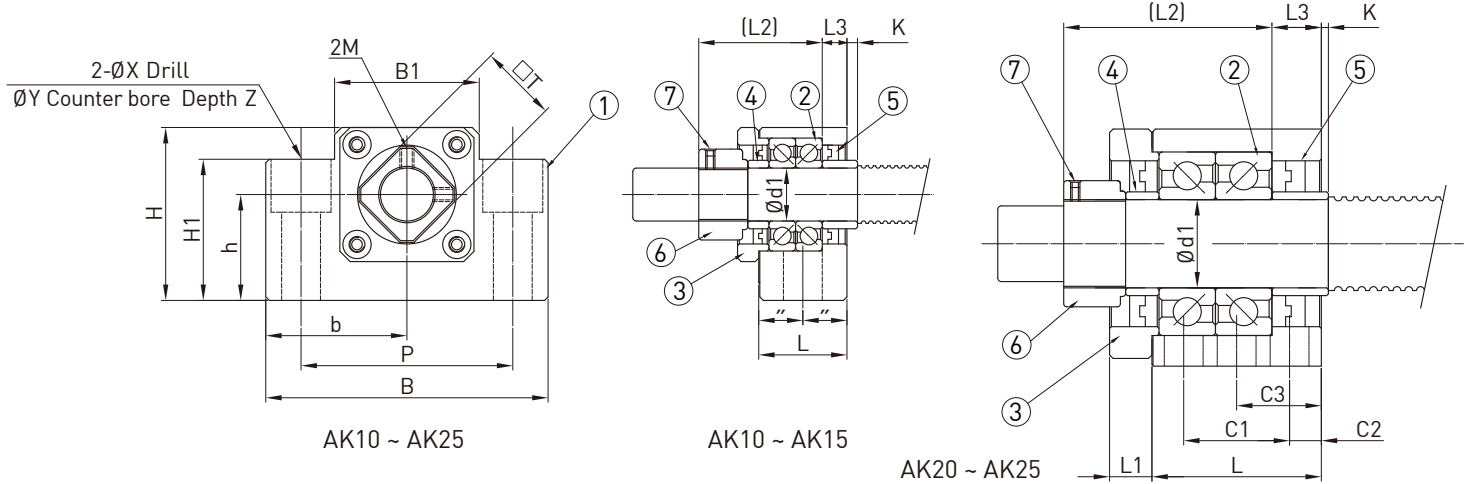

Part No.	Part name	Qty
1	Housing	1
2	Bearing	1 set
3	Holding lid	1
4	Collar	2
5	Seal	2
6	Set screw	1
7	Hexagonal socket-head setscrew with set piece	2



Specification	Main dimensions (mm)																				Weight (kg)	
	d1	L	L1	L2	L3	K	B	H	b (Note 1)	h (Note 1)	B1	H1	P	X	Y	Z	M	T	C1	C2		C3
AK10	10	24	6	29.5	6	-0.5	70	43	35	25	36	35	52	9	14	11	M3	16	-	-	-	0.5
AK12	12	24	6	29.5	6	-0.5	70	43	35	25	36	35	52	9	14	11	M4	19	-	-	-	0.5
AK15	15	25	6	36	5	5	80	49	40	30	41	40	60	11	17	15	M4	22	-	-	-	0.65
AK20	20	42	10	50	10	1	95	58	47.5	30	56	45	75	11	17	15	M4	30	22	10	-	1.45
AK25	25	48	12	59	14	0	105	68	52.5	35	66	25	85	11	-	-	M6	35	30	9	24	1.92

Specification	Collar dimensions (mm)		
	d	D	W
AK10	10	15.5	5.5
AK12	12	15.5	5.5
AK15	15	19.7	10
AK20	20	25.5	11
AK25	25	29.5	14

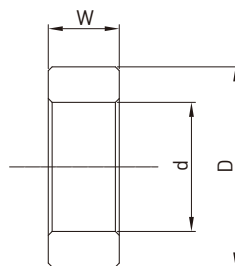

- Note: 1. Tolerance of Height (h) and tolerance of Width (b) refer to the precision of standard bearing.
2. If $K > 0$, the spacer is over the face of the housing. If $K < 0$, the spacer is under the face of the housing.
3. Specification are subject to change without notice.

8.1.2 AF Series

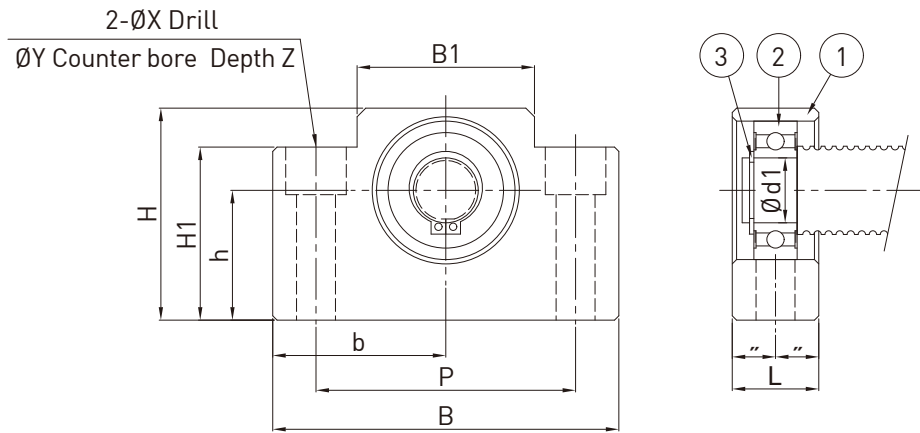

Part No.	Part name	Qty
1	Housing	1
2	Bearing	1
3	Snap ring	1

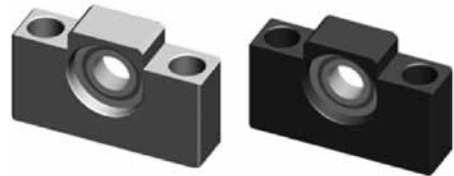

Specification	Main dimensions (mm)														
	d1	L	B	H	b (Note 1)	h (Note 1)	B1	H1	P	X	Y	Z	Bearing	Snap ring	Weight (kg)
AF10	8	20	70	43	35	25	36	35	52	9	14	11	608ZZ	S08	0.37
AF12	10	20	70	43	35	25	36	35	52	9	14	11	6000ZZ	S10	0.37
AF15	15	20	80	49	40	30	41	40	60	9	14	11	6002ZZ	S15	0.45
AF20	20	26	95	58	47.5	30	56	45	75	11	17	15	6204ZZ	S20	0.75
AF25	25	30	105	68	52.5	35	66	25	85	11	-	-	6205ZZ	S25	0.95

Note: 1. Tolerance of Height (h) and tolerance of Width (b) refer to the precision of standard bearing.

2. Specification are subject to change without notice.

8.1.3 BK Series

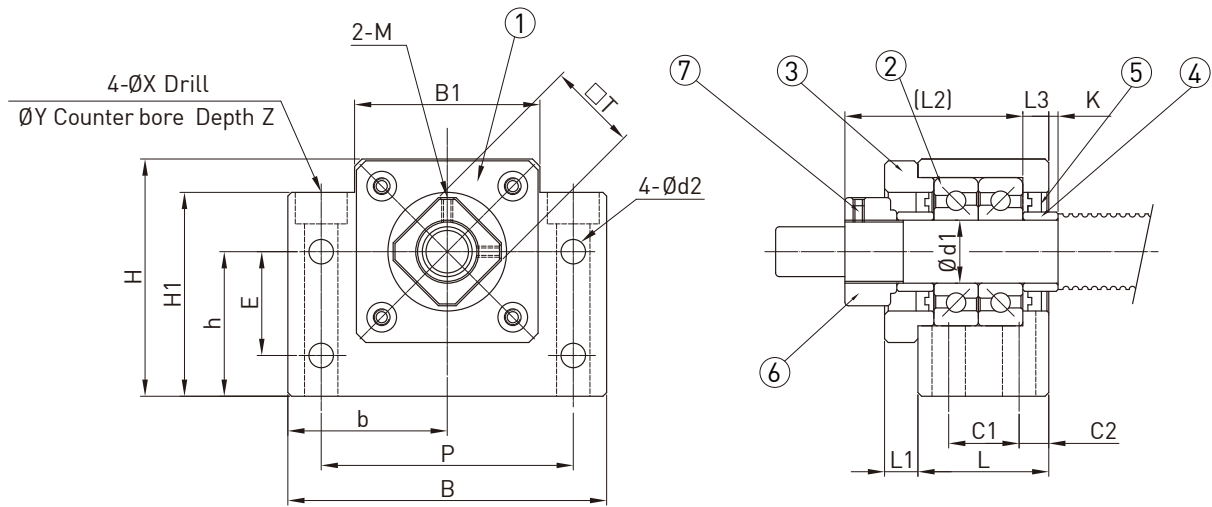

Part No.	Part name	Qty
1	Housing	1
2	Bearing	1 set
3	Holding lid	1
4	Collar	2
5	Seal	2
6	Set screw	1
7	Hexagonal socket-head setscrew with set piece	2



Specification	Main dimensions (mm)																				Weight (kg)		
	d1	L	L1	L2	L3	K	B	H	b (Note 1)	h (Note 1)	B1	H1	E	P	C1	C2	d2	X	Y	Z		M	T
BK10	10	25	5	29.5	5	0.5	60	39	30	22	34	32.5	15	46	13	6	5.5	6.6	10.8	5	M3	16	0.4
BK12	12	25	5	29.5	5	0.5	60	43	30	25	34	32.5	18	46	13	6	5.5	6.6	10.8	1.5	M4	19	0.45
BK15	15	27	6	32	6	0	70	48	35	28	40	38	18	54	15	6	5.5	6.6	11	6.5	M4	22	0.6
BK17	17	35	9	44	7	0	86	64	43	39	50	55	28	68	19	8	6.6	9	14	8.5	M4	24	1.3
BK20	20	35	8	43	8	0	88	60	44	34	52	50	22	70	19	8	6.6	9	14	8.5	M4	30	1.3
BK25	25	42	12	54	9	0	106	80	53	48	64	70	33	85	22	10	9	11	17	11	M6	35	2.4
BK30	30	45	14	61	9	0	128	89	64	51	76	78	33	102	23	11	11	14	20	13	M6	40	3.4
BK35	35	50	14	67	12	0	140	96	70	52	88	79	35	114	26	12	11	14	20	13	M6	50	4.4
BK40	40	61	18	76	15	0	160	110	80	60	100	90	37	130	33	14	14	18	26	17.5	M6	50	6.8

Specification	Collar dimensions (mm)		
	d	D	W
BK10	10	15.5	5.5
BK12	12	15.5	5.5
BK15	15	19.7	6
BK17	17	24.5	7
BK20	20	25.5	8
BK25	25	29.5	9
BK30	30	37.5	9
BK35	35	49.7	12
BK40	40	52.5	15

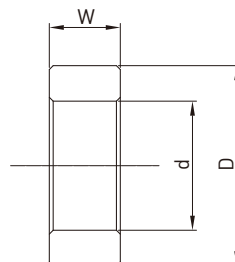

- Note: 1. Tolerance of Height (h) and tolerance of Width (b) refer to the precision of standard bearing.
2. If $K > 0$, the spacer is over the face of the housing. If $K < 0$, the spacer is under the face of the housing.
3. Specification are subject to change without notice.

8.1.4 BF Series

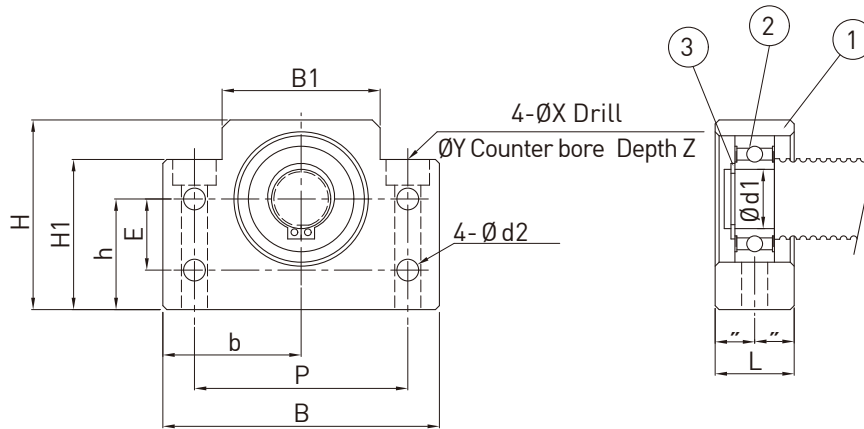

Part No.	Part name	Qty
1	Housing	1
2	Bearing	1
3	Snap ring	1



Specification	Main dimensions (mm)																Weight (kg)
	d1	L	B	H	b (Note 1)	h (Note 1)	B1	H1	E	P	d2	X	Y	Z	Bearing	Snap ring	
BF10	8	20	60	39	30	22	34	32.5	15	46	5.5	6.6	10.8	5	608ZZ	S08	0.3
BF12	10	20	60	43	30	25	34	32.5	18	46	5.5	6.6	10.8	1.5	6000ZZ	S10	0.35
BF15	15	20	70	48	35	28	40	38	18	54	5.5	6.6	11	6.5	6002ZZ	S15	0.4
BF17	17	23	86	64	43	39	50	55	28	68	6.6	9	14	8.5	6203ZZ	S17	0.75
BF20	20	26	88	60	44	34	52	50	22	70	6.6	9	14	8.5	6004ZZ	S20	0.77
BF25	25	30	106	80	53	48	64	70	33	85	9	11	17	11	6205ZZ	S25	1.45
BF30	30	32	128	89	64	51	76	78	33	102	11	14	20	13	6206ZZ	S30	1.95
BF35	35	32	140	96	70	52	88	79	35	114	11	14	20	13	6207ZZ	S35	2.25
BF40	40	37	160	110	80	60	100	90	37	130	14	18	26	17.5	6208ZZ	S40	3.3

Note: 1. Tolerance of Height (h) and tolerance of Width (b) refer to the precision of standard bearing.

2. Specification are subject to change without notice.

8.1.5 EK Series

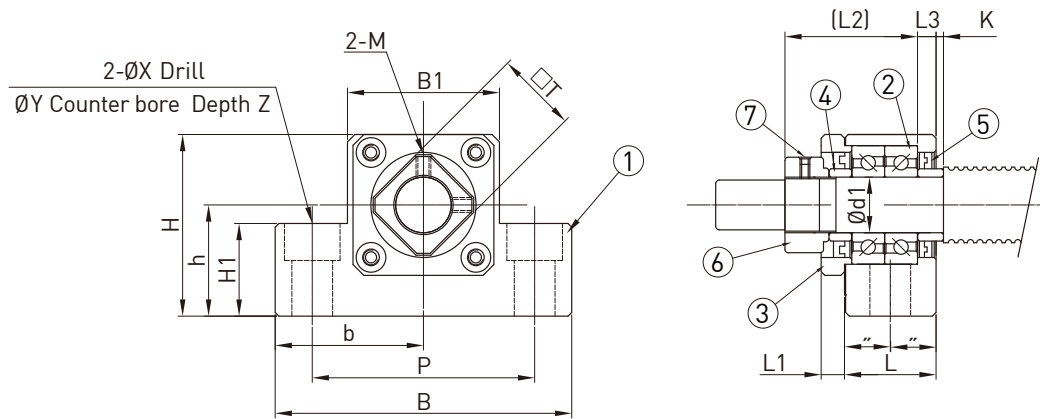

Part No.	Part name	Qty
1	Housing	1
2	Bearing	1 set
3	Holding lid	1
4	Collar	2
5	Seal	2
6	Set screw	1
7	Hexagonal socket-head setscrew with set piece	2



Specification	Main dimensions (mm)																	Weight (kg)	
	d1	L	L1	L2	L3	K	B	H	b (Note 1)	h (Note 1)	B1	H1	P	X	Y	Z	M		T
EK05	5	16.5	-	18.5	3.5	0	36	21	18	11	20	8	28	4.5	-	-	M3	11	0.12
EK06	6	20	-	22	3.5	1.5	42	25	21	13	18	20	30	5.5	9.5	11	M3	12	0.18
EK08	8	23	-	26	4	1.5	52	32	26	17	25	26	38	6.6	11	12	M3	14	0.27
EK10	10	24	6	29.5	6	-0.5	70	43	35	25	36	24	52	9	-	-	M3	16	0.47
EK12	12	24	6	29.5	6	-0.5	70	43	35	25	36	24	52	9	-	-	M4	19	0.45
EK15	15	25	6	36	5	5	80	49	40	30	41	25	60	11	-	-	M4	22	0.6
EK20	20	42	10	50	10	1	95	58	47.5	30	56	25	75	11	-	-	M4	30	1.35

Specification	Collar dimensions (mm)		
	d	D	W
EK05	5	8	3.5
EK06	6	9.7	5
EK08	8	11.7	5.5
EK10	10	15.5	5.5
EK12	12	15.5	5.5
EK15	15	19.7	10
EK20	20	25.5	11

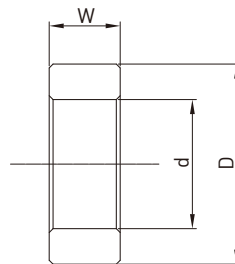

Note: 1. Tolerance of Height (h) and tolerance of Width (b) refer to the precision of standard bearing.

2. If $K > 0$, the spacer is over the face of the housing. If $K < 0$, the spacer is under the face of the housing.

3. Specification are subject to change without notice.

8.1.6 EF Series

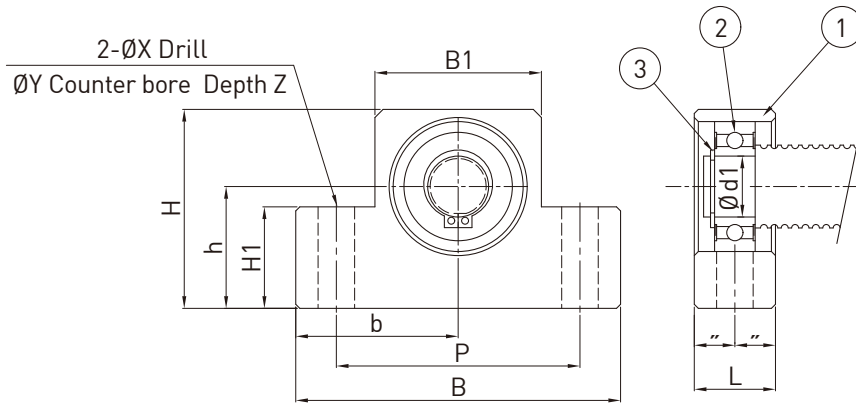

Part No.	Part name	Qty
1	Housing	1
2	Bearing	1
3	Snap ring	1

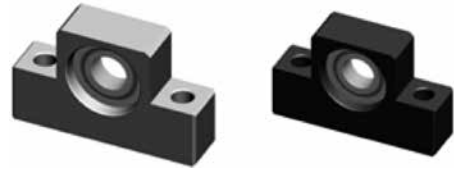

Specification	Main dimensions (mm)														
	d1	L	B	H	b (Note 1)	h (Note 1)	B1	H1	P	X	Y	Z	Bearing	Snap ring	Weight (kg)
EF06	6	12	42	25	21	13	18	20	30	5.5	9.5	11	606ZZ	S06	0.1
EF08	6	14	52	32	26	17	25	26	38	6.6	11	12	606ZZ	S06	0.16
EF10	8	20	70	43	35	25	36	24	52	9	-	-	608ZZ	S08	0.35
EF12	10	20	70	43	35	25	36	24	52	9	-	-	6000ZZ	S10	0.35
EF15	15	20	80	49	40	30	41	25	60	9	-	-	6002ZZ	S15	0.4
EF20	20	26	95	58	47.5	30	56	25	75	11	-	-	6204ZZ	S20	0.65

Note: 1. Tolerance of Height (h) and tolerance of Width (b) refer to the precision of standard bearing.

2. Specification are subject to change without notice.

8.1.7 FK Series

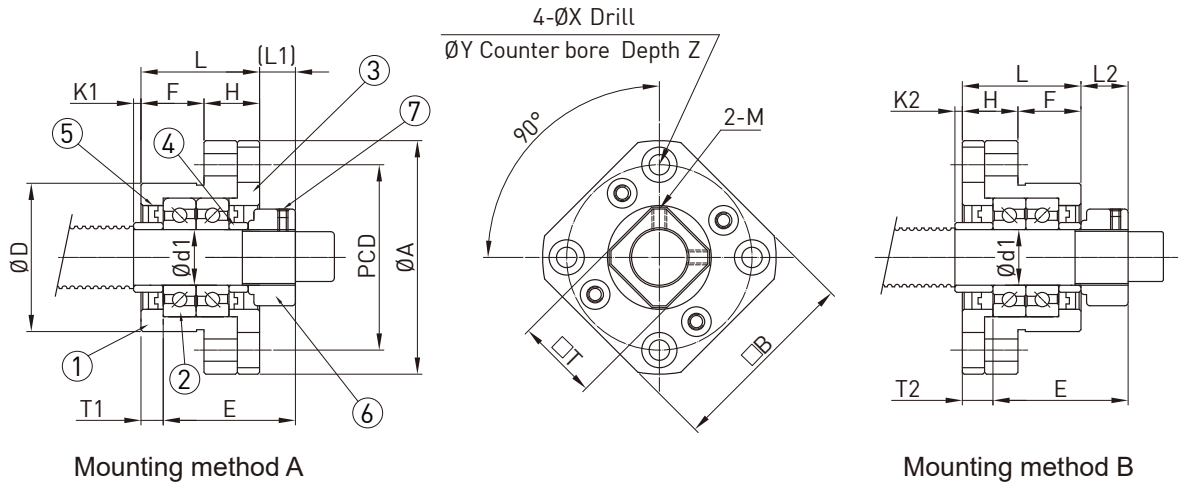

Part No.	Part name	Qty
1	Housing	1
2	Bearing	1 set
3	Holding lid	1
4	Collar	2
5	Seal	2
6	Set screw	1
7	Hexagonal socket-head setscrew with set piece	2

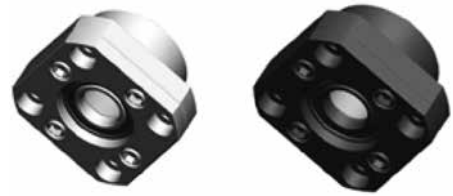

Specification	Main dimensions (mm)																			Weight (kg)	
	d1	L	H	F	E	D (Note 1)	A	PCD	B	Mounting method A			Mounting method B			X	Y	Z	M		T
										L1	T1	K1	L2	T2	K2						
FK05	5	16.5	6	10.5	18.5	20	34	26	26	5.5	3.5	0	5	3	0.5	3.4	6.5	4	M3	11	0.1
FK06	6	20	7	13	22	22	36	28	28	5.5	3.5	1.5	6.5	4.5	0.5	3.4	6.5	4	M3	12	0.1
FK08	8	23	9	14	26	28	43	35	35	7	4	1.5	8	5	0.5	3.4	6.5	4	M3	14	0.16
FK10	10	27	10	17	29.5	34	52	42	42	7.5	5	0.5	8.5	6	-0.5	4.5	8	5	M3	16	0.25
FK12	12	27	10	17	29.5	36	54	44	44	7.5	5	0.5	8.5	6	-0.5	4.5	8	5	M4	19	0.26
FK15	15	32	15	17	36	40	63	50	52	10	6	4	12	8	2	5.5	9.5	6	M4	22	0.4
FK17	17	45	22	23	47	50	77	62	61	11	9	1	14	12	-2	6.6	11	10	M4	24	0.85
FK20	20	52	22	30	50	57	85	70	68	8	10	1	12	14	-3	6.6	11	10	M4	30	1.2
FK25	25	57	27	30	60	63	98	80	79	13	10	5	20	17	-2	9	15	13	M6	35	1.6
FK30	30	62	30	32	61	75	117	95	93	11	12	-3	17	18	-9	11	17.5	15	M6	40	2.38

Specification	Collar dimensions (mm)		
	d	D	W
FK05	5	8	3.5
FK06	6	9.7	5
FK08	8	11.7	5.5
FK10	10	15.5	5.5
FK12	12	15.5	5.5
FK15	15	19.7	10
FK17	17	24.5	10
FK20	20	25.5	11
FK25	25	29.5	15
FK30	30	37.5	9

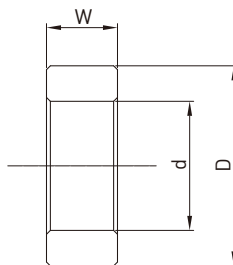

- Note: 1. Diameter tolerance (D) refer to the precision of standard bearing.
- 2. If K1 and K2 > 0, the spacer is over the face of the housing. If K1 and K2 < 0, the spacer is under the face of the housing.
- 3. Specification are subject to change without notice.

8.1.8 FF Series

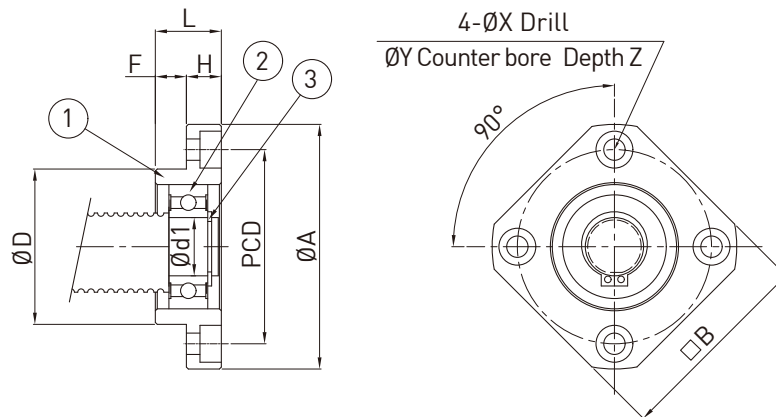

Part No.	Part name	Qty
1	Housing	1
2	Bearing	1
3	Snap ring	1

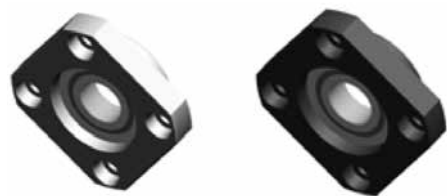

Specification	Main dimensions (mm)													
	d1	L	H	F	D (Note 1)	A	PCD	B	X	Y	Z	Bearing	Snap ring	Weight (kg)
FF06	6	10	6	4	22	36	28	28	3.4	6.5	4	606ZZ	S06	0.08
FF10	8	12	7	5	28	43	35	35	3.4	6.5	4	608ZZ	S08	0.1
FF12	10	15	7	8	34	52	42	42	4.5	8	4	6000ZZ	S10	0.15
FF15	15	17	9	8	40	63	50	52	5.5	9.5	5.5	6002ZZ	S15	0.22
FF17	17	20	11	9	50	77	62	61	6.6	11	6.5	6203ZZ	S17	0.35
FF20	20	20	11	9	57	85	70	68	6.6	11	6.5	6204ZZ	S20	0.45
FF25	25	24	14	10	63	98	80	79	9	14	8.5	6205ZZ	S25	0.66
FF30	30	27	18	9	75	117	95	93	11	17	11	6206ZZ	S30	1.05

Note: 1. Diameter tolerance [D] refer to the precision of standard bearing.

2. Specification are subject to change without notice.

8.1.9 LK Series

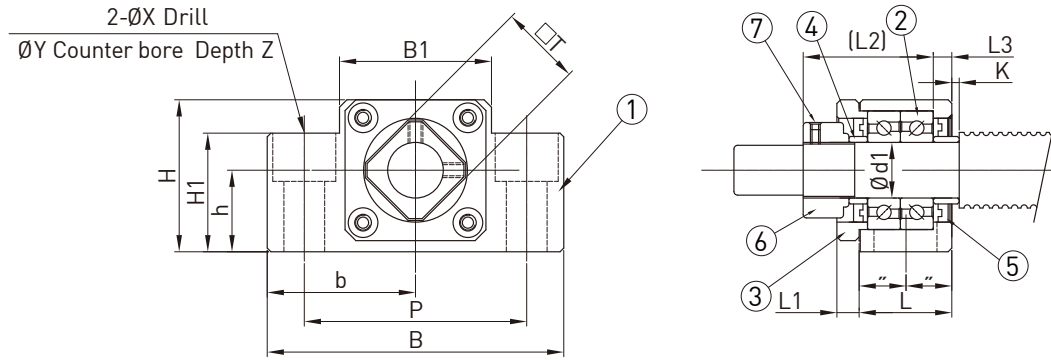

Part No.	Part name	Qty
1	Housing	1
2	Bearing	1set
3	Holding lid	1
4	Collar	2
5	Seal	2
6	Set screw	1
7	Hexagonal socket-head setscrew with set piece	2

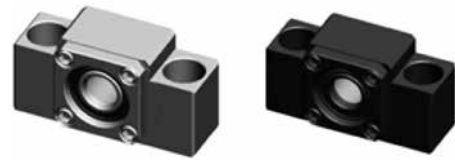

Specification	Main dimensions (mm)																		
	d1	L	L1	L2	L3	K	B	H	b [Note 1]	h [Note 1]	B1	H1	P	X	Y	Z	M	T	Weight (kg)
LK08	8	22.5	-	26	3.5	2	62	31	31	15.5	30	25.5	46	9	14	12.5	M3	14	0.28
LK10	10	24	6	29.5	6	-0.5	70	38	35	20	36	30	52	9	14	10	M3	16	0.44
LK12	12	24	6	29.5	6	-0.5	70	38	35	20	36	30	52	9	14	10	M4	19	0.42
LK15	15	25	6	36	5	5	80	41	40	22	41	32	60	11	17	13	M4	22	0.51

Specification	Collar dimensions (mm)		
	d	D	W
LK08	8	11.7	5.5
LK10	10	15.5	5.5
LK12	12	15.5	5.5
LK15	15	19.7	10

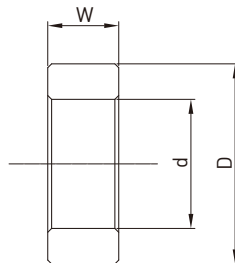

- Note: 1. Tolerance of Height (h) and tolerance of Width (b) refer to the precision of standard bearing.
2. If $K > 0$, the spacer is over the face of the housing. If $K < 0$, the spacer is under the face of the housing.
3. Specification are subject to change without notice.

8.1.10 LF Series

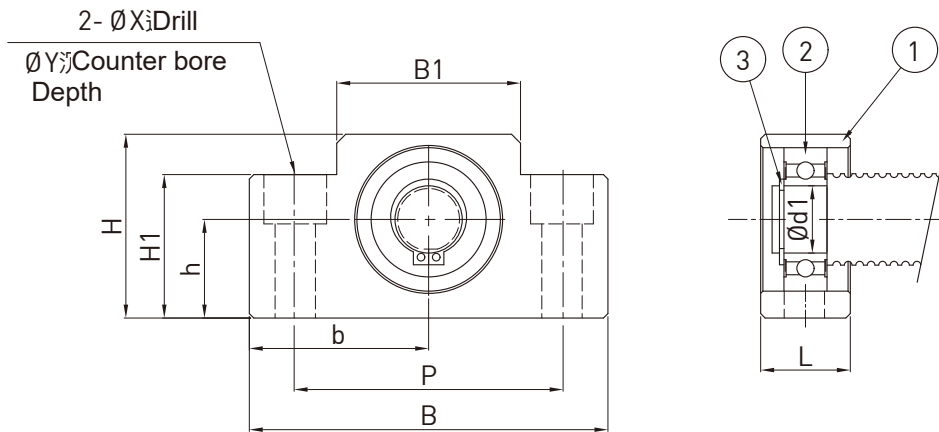

Part No.	Part name	Qty
1	Housing	1
2	Bearing	1
3	Snap ring	1

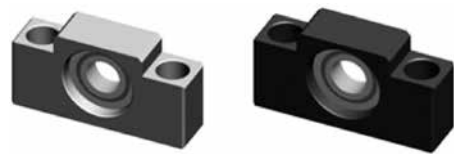

Specification	Main dimensions (mm)													Weight (kg)	
	d1	L	B	H	b (Note 1)	h (Note 1)	B1	H1	P	X	Y	Z	Bearing		Snap ring
LF08	6	16	62	31	31	15.5	30	25.5	46	9	14	12.5	606ZZ	S06	0.19
LF12	10	20	70	38	35	20	36	30	52	9	14	10	6000ZZ	S10	0.3
LF15	15	20	80	41	40	22	41	32	60	9	14	11	6002ZZ	S15	0.35

Note: 1. Tolerance of Height (h) and tolerance of Width (b) refer to the precision of standard bearing.
2. Specification are subject to change without notice.

8.1.11 LFA Series

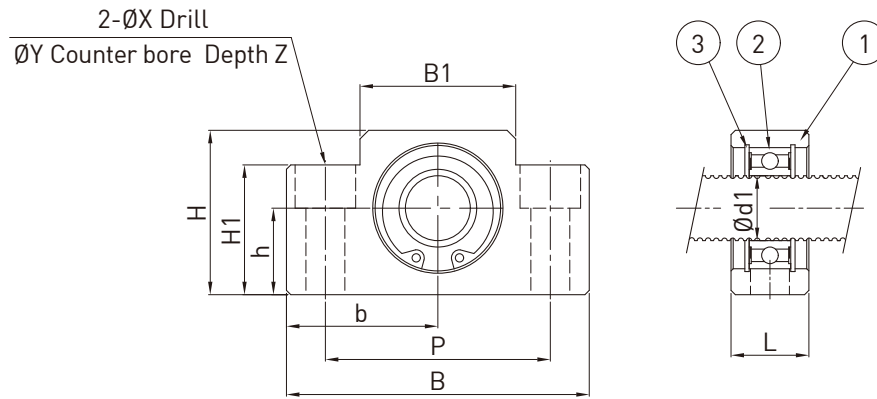

Part No.	Part name	Qty
1	Housing	1
2	Bearing	1
3	Snap ring	2

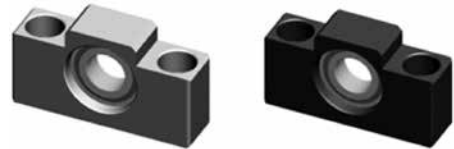

Specification	Main dimensions (mm)														Weight (kg)
	d1	L	B	H	b (Note 1)	h (Note 1)	B1	H1	P	X	Y	Z	Bearing	Snap ring	
LFA12	12	18	62	31	31	15.5	30	25.5	46	9	14	12.5	6801ZZ	R21	0.2
LFA15	15	18	70	38	35	20	36	30	52	9	14	10	6902ZZ	R28	0.26
LFA20	20	22	80	41	40	22	41	32	60	11	17	13	6804ZZ	R32	0.35
LFA25	25	22	95	58	47.5	30	56	45	75	11	17	15	6005ZZ	R47	0.61

Note: 1. Tolerance of Height (h) and tolerance of Width (b) refer to the precision of standard bearing.

2. Specification are subject to change without notice.

8.1.12 Suggestive machining dimension for support units

- Fixed Side - BK Series

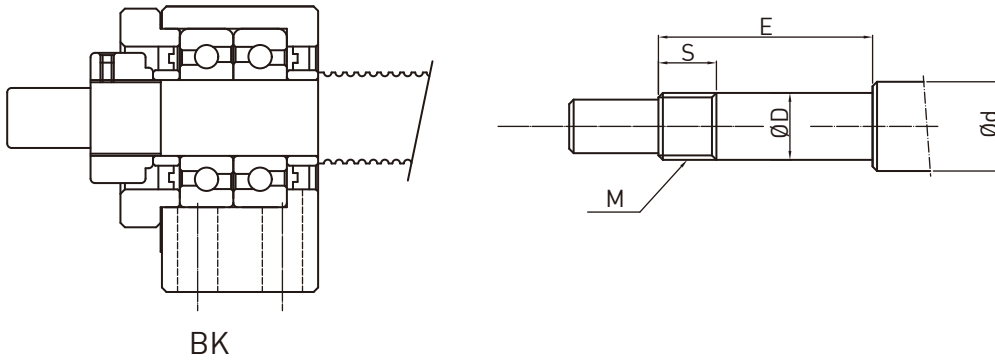

Specification	Main dimensions (mm)				
	d	D	E	M	S
BK10	10-15	10	36	M10 x 1	12
BK12	14-18	12	36	M12 x 1	12
BK15	20	15	40	M15 x 1	12
BK17	25-28	17	53	M17 x 1	17
BK20	25-28	20	53	M20 x 1	15
BK25	30-36	25	66	M25 x 1.5	20
BK30	40	30	73	M30 x 1.5	25
BK35	45	35	82	M30 x 1.5	26
BK40	50	40	94	M40 x 1.5	30

Note: This chart is the suggestive specification(E,S,M) for ball screw end machining to match with the support units, for the rest of the specifications please refer to the ball screw manual.

• Fixed Side - FK, EK, AK, LK Series

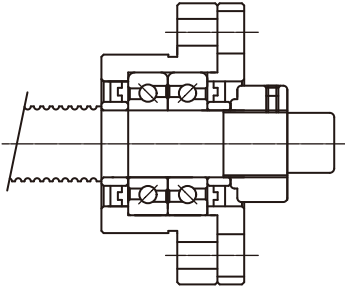

FK series mounting way A

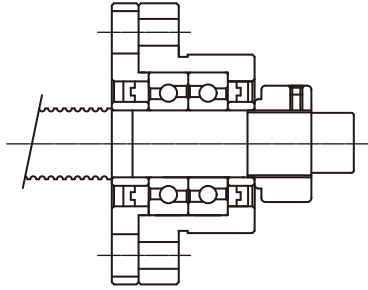

FK series mounting way B

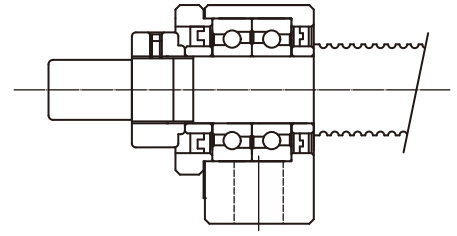

EK, AK, LK series
mounting way B

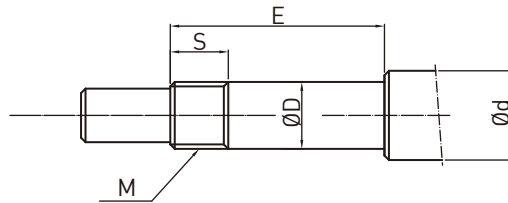

Specification				Main dimensions (mm)				
FK	EK	AK	LK	d	D	E	M	S
FK05	EK05	-	-	8	5	23	M5 x 0.5	7
FK06	EK06	-	-	8	6	28	M6 x 0.75	8
FK08	EK08	-	LK08	10-12	8	32	M8 x 1	10
FK10	EK10	AK10	LK10	10-15	10	36	M10 x 1	12
FK12	EK12	AK12	LK12	14-18	12	36	M12 x 1	12
FK15	EK15	AK15	LK15	20	15	48	M15 x 1	13
FK17	-	-	-	25-28	17	59	M17 x 1	17
FK20	EK20	AK20	-	25-28	20	64	M20 x 1	16
FK25	-	AK25	-	30-36	25	76	M25 x 1.5	20
FK30	-	-	-	40	30	73	M30 x 1.5	25

Note: This chart is the suggestive specification(E,S,M) for ball screw end machining to match with the support units, for the rest of the specifications please refer to the ball screw manual.

• Supported Side

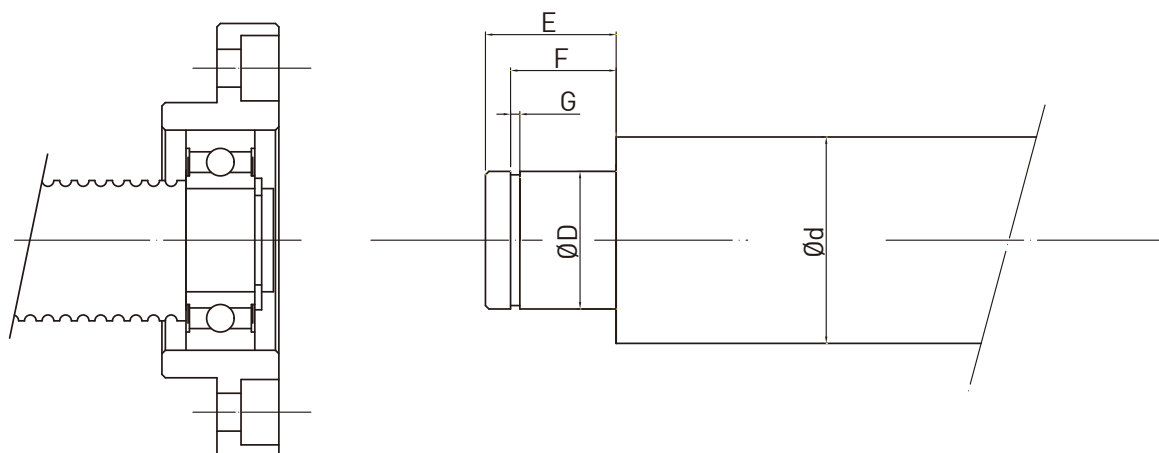

Specification					Main dimensions (mm)				
FF	EF	BF	AF	LF	d	D	E	F	G
FF06	EF06	-	-	-	8	6	9	6.8	0.8
-	EF08	-	-	LF08	10-12	6	9	6.8	0.8
FF10	EF10	BF10	AF10	-	10-15	8	10	7.9	0.9
FF12	EF12	BF12	AF12	-	14-18	10	11	9.15	1.15
FF15	EF15	BF15	AF15	LF12	20	15	13	10.15	1.15
FF17	-	BF17	-	LF15	25-28	17	16	13.15	1.15
FF20	EF20	(BF20)	AF20	-	25-28	20	19(16)	15.35(13.35)	1.35
FF25	-	BF25	AF25	-	30-36	25	20	16.35	1.35
FF30	-	BF30	-	-	40	30	21	17.75	1.75
-	-	BF35	-	-	45	35	22	18.75	1.75
-	-	BF40	-	-	50	40	23	19.95	1.95

Note: This chart is the suggestive specification(E,F,G) for ball screw end machining to match with the support units, for the rest of the specifications please refer to the ball screw manual.

8.1.13 Standard Lock Nut

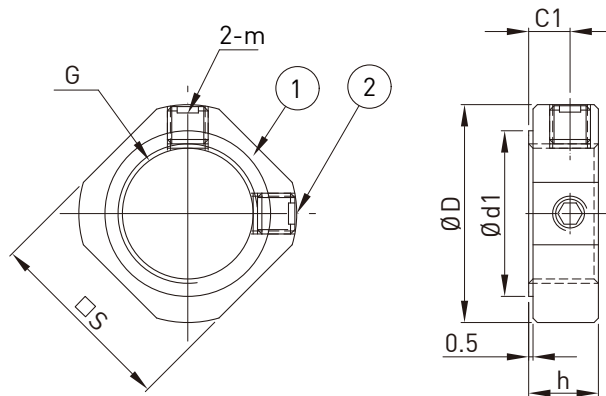

Part No.	Part name	Qty
1	Lock Nut	1
2	Hexagonal socket-head setscrew with set piece	2

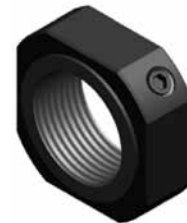

Specification	Main dimensions (mm)							Tightening Torque (reference) (N-m)	Set screw tightening torque (reference) (N-m)
	D	h	d1	m	c1	G	s		
M5 x 0.5	12.5	5	8	M3	2.7	M5 x 0.5	11	1.5	0.63
M6 x 0.75	13.5	5	9	M3	2.7	M6 x 0.75	12	2	0.63
M8 x 1.0	16	6.5	11	M3	4	M8 x 1.0	14	2.5	0.63
M10 x 1.0	19	8	13	M3	5.5	M10 x 1.0	16	3	0.63
M12 x 1.0	22	8	16	M4	5.5	M12 x 1.0	19	6.5	1.5
M15 x 1.0	25	8	19	M4	4.75	M15 x 1.0	22	8	1.5
M17 x 1.0	29	13	21	M4	9	M17 x 1.0	24	9.5	1.5
M20 x 1.0	35	11	27	M4	7	M20 x 1.0	30	17	1.5
M25 x 1.5	43	15	32	M6	10	M25 x 1.5	35	21	5.2
M30 x 1.5	48	20	37	M6	14	M30 x 1.5	40	32	5.2
M35 x 1.5	60	21	47	M6	14	M35 x 1.5	50	48	5.2
M40 x 1.5	62	25	47	M6	18	M40 x 1.5	50	72	5.2

8.2 Heavy Load Support Unit Specification

8.2.1 WBK Series

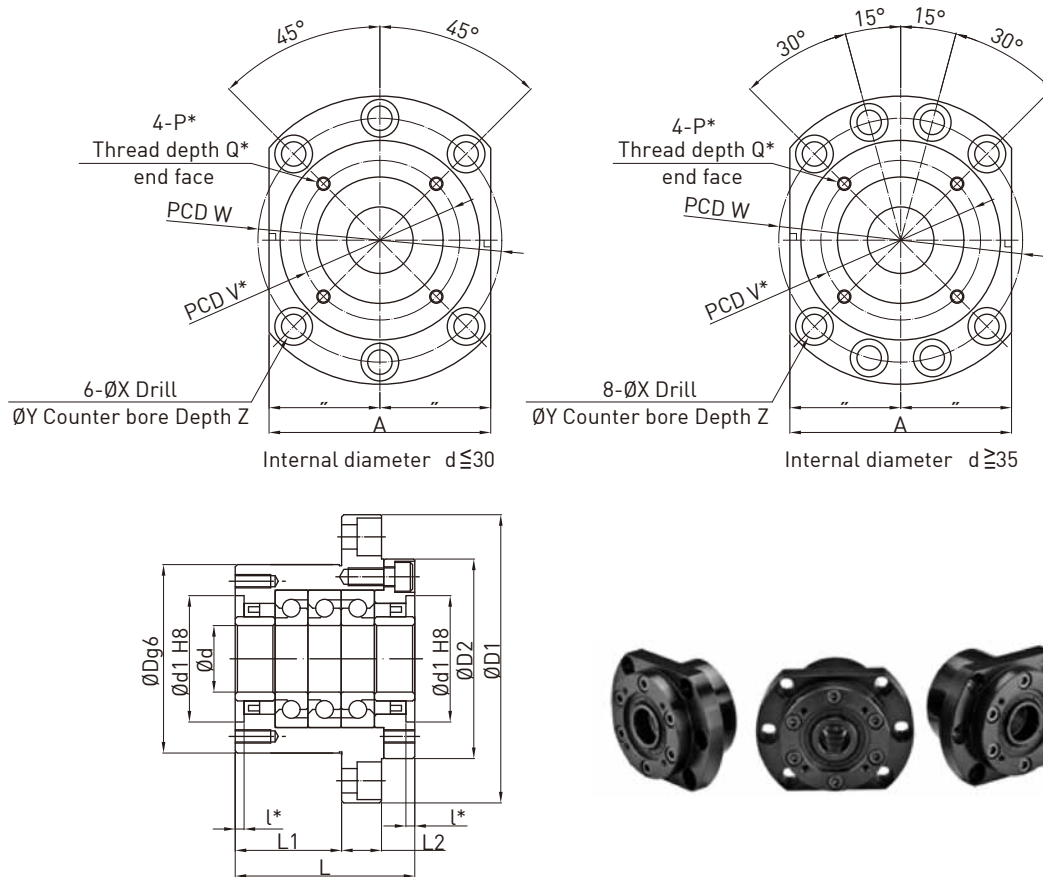

Specification	Main dimensions (mm)															Weight (kg)		
	d1	Dg6	D1	D2	L	L1	L2	A	W	X	Y	Z	d1 H8	L*	V*		P*	Q*
WBK15 DF	15	70 ^{-0.01/-0.029}	106	72	60	32	15	80	88	9	14	8.5	45 ^{+0.039/-0}	3	58	M5	10	1.9
WBK17 DF	17	70 ^{-0.01/-0.029}	106	72	60	32	15	80	88	9	14	8.5	45 ^{+0.039/-0}	3	58	M5	10	1.9
WBK20 DF	20	70 ^{-0.01/-0.029}	106	72	60	32	15	80	88	9	14	8.5	45 ^{+0.039/-0}	3	58	M5	10	1.9
WBK25 DF					66	33												3.1
WBK25 DFD	25	85 ^{-0.012/-0.034}	130	90	81	48	18	100	110	11	17.5	11	57 ^{+0.046/-0}	4	70	M6	12	3.4
WBK25 DFF					96	48												3.8
WBK30 DF					66	33												3
WBK30 DFD	30	85 ^{-0.012/-0.034}	130	90	81	48	18	100	110	11	17.5	11	57 ^{+0.046/-0}	4	70	M6	12	3.3
WBK30 DFF					96	48												3.8
WBK35 DF					66	33												3.4
WBK35 DFD	35	95 ^{-0.012/-0.034}	142	102	81	48	18	106	121	11	17.5	11	69 ^{+0.046/-0}	4	80	M6	12	4.3
WBK35 DFF					96	48												5
WBK40 DF					66	33												3.6
WBK40 DFD	40	95 ^{-0.012/-0.034}	142	102	81	48	18	106	121	11	17.5	11	69 ^{+0.046/-0}	4	80	M6	12	4.2
WBK40 DFF					96	48												5.7

* Specification are subject to change without notice.

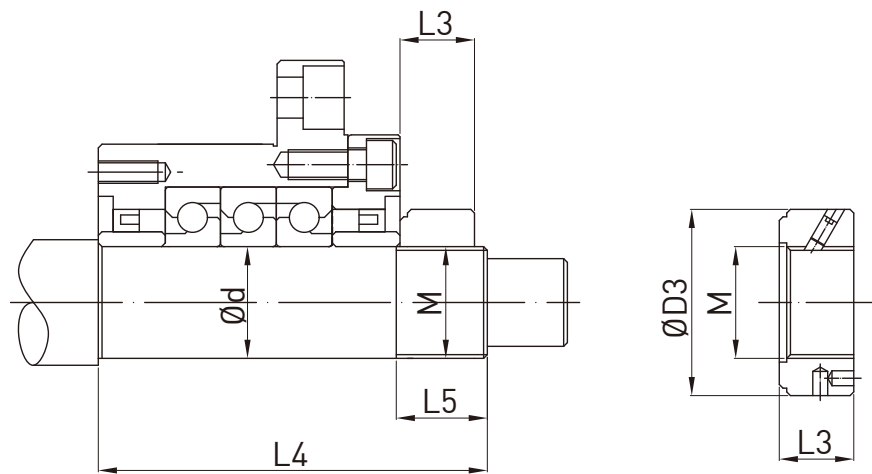

Internal diameter (mm)	Specification	Lock Nut			Support base installation part		
		M	D3	L3	d	L4	L5
Ø15	WBK15 DF	M15	30	14	15	81	23
Ø17	WBK17 DF	M17	32	16	17	81	23
Ø20	WBK20 DF	M20	38	16	20	81	23
Ø25	WBK25 DF	M25	38	18	25	89	26
	WBK25 DFD					104	
	WBK25 DFF					119	
Ø30	WBK30 DF	M30	45	18	30	89	26
	WBK30 DFD					104	
	WBK30 DFF					119	
Ø35	WBK35 DF	M35	52	18	35	92	30
	WBK35 DFD					107	
	WBK35 DFF					122	
Ø40	WBK40 DF	M40	58	20	40	92	30
	WBK40 DFD					107	
	WBK40 DFF					122	

8.2.2 Heavy Load Lock Nut

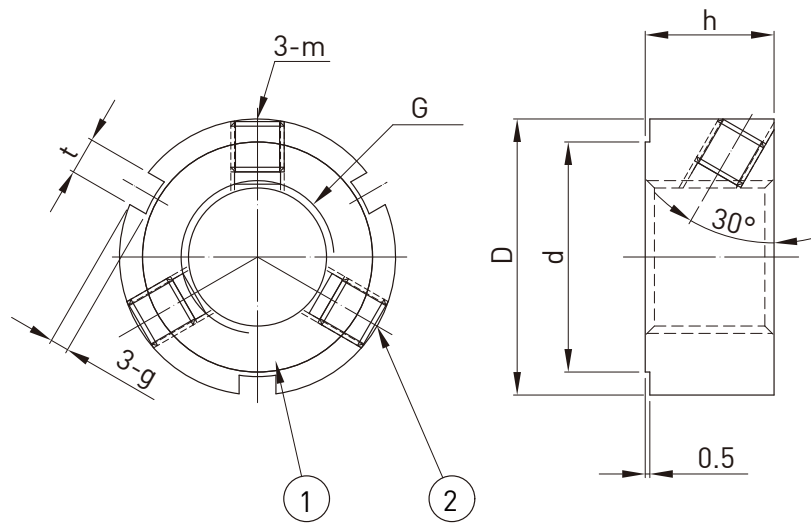

Part No.	Part name	Qty
1	Lock Nut	1
2	Hexagonal socket-head setscrew with set piece	3



Specification	Main dimensions (mm)							Tightening Torque (reference) (N-m)	Set screw tightening torque (reference) (N-m)
	D	h	d	g	t	m	G		
M15 x 1.0	30	14	25	2	4	M5	M15 x 1.0	35	3
M17 x 1.0	32	16	27	2	4	M5	M17 x 1.0	42	3
M20 x 1.0	38	16	33	2	4	M6	M20 x 1.0	46	5.2
M25 x 1.5	38	18	33	2	5	M6	M25 x 1.5	87	5.2
M30 x 1.5	45	18	40	2	5	M6	M30 x 1.5	105	5.2
M35 x 1.5	52	18	47	2	5	M8	M35 x 1.5	340	12.5
M40 x 1.5	58	20	52	2.5	6	M8	M40 x 1.5	500	12.5

Support Unit Technical Information

Publication Date : December 2014, first edition

Print Date : July 2019, third edition

1. HIWIN is a registered trademark of HIWIN Technologies Corp. For your protection, avoid buying counterfeit products from unknown sources.
 2. Actual products may differ from specifications and photos provided in this catalog. These differences may be the result of various factors including product improvements.
 3. HIWIN will not sell or export products or processes restricted under the "Foreign Trade Act" or related regulations. Export of restricted products should be approved by proper authorities in accordance with relevant laws and shall not be used to manufacture or develop nuclear, biochemical, missiles or other weapons.
 4. HIWIN website for patented product directory: http://www.hiwin.tw/Products/Products_patents.aspx
-



Subsidiaries / Research Center

HIWIN GmbH
OFFENBURG, GERMANY
www.hiwin.de
www.hiwin.eu
info@hiwin.de

HIWIN JAPAN
KOBE · TOKYO · NAGOYA · NAGANO ·
TOHOKU · SHIZUOKA · HOKURIKU ·
HIROSHIMA · FUKUOKA · KUMAMOTO,
JAPAN
www.hiwin.co.jp
info@hiwin.co.jp

HIWIN USA
CHICAGO, U.S.A.
www.hiwin.com
info@hiwin.com

HIWIN Srl
BRUGHERIO, ITALY
www.hiwin.it
info@hiwin.it

HIWIN Schweiz GmbH
JONA, SWITZERLAND
www.hiwin.ch
info@hiwin.ch

HIWIN s.r.o.
BRNO, CZECH REPUBLIC
www.hiwin.cz
info@hiwin.cz

HIWIN SINGAPORE
SINGAPORE
www.hiwin.sg
info@hiwin.sg

HIWIN KOREA
SUWON · MASAN, KOREA
www.hiwin.kr
info@hiwin.kr

HIWIN CHINA
SUZHOU, CHINA
www.hiwin.cn
info@hiwin.cn

Mega-Fabs Motion Systems, Ltd.
HAIFA, ISRAEL
www.mega-fabs.com
info@mega-fabs.com

HIWIN TECHNOLOGIES CORP.

No. 7, Jingke Road,
Taichung Precision Machinery Park,
Taichung 40852, Taiwan
Tel: +886-4-23594510
Fax: +886-4-23594420
www.hiwin.tw
business@hiwin.tw