

Ball Spline

Technical Information





Multi-Axis Robot

- Pick-and-Place / Assembly / Array and Packaging / Semiconductor / Electro-Optical Industry / Automotive Industry / Food Industry
- Articulated Robot
 - Delta Robot
 - SCARA Robot
 - Wafer Robot
 - Electric Gripper
 - Integrated Electric Gripper
 - Rotary Joint



Single-Axis Robot

- Precision / Semiconductor / Medical / FPD
- KK, SK
 - KS, KA
 - KU, KE, KC



Torque Motor Rotary Table

- Medical / Automotive Industry / Machine Tools / Machinery Industry
- RAB Series
 - RAS Series
 - RCV Series
 - RCH Series



Ballscrew

- Precision Ground / Rolled
- Super S Series
 - Super T Series
 - Mini Roller
 - Ecological & Economical Lubrication Module E2
 - Rotating Nut (R1)
 - Energy-Saving & Thermal-Controlling (Cool Type)
 - Heavy Load Series (RD)
 - Ball Spline



Linear Guideway

- Automation / Semiconductor / Medical
- Ball Type--HG, EG, WE, MG, CG
 - Quiet Type--QH, QE, QW, QR
 - Other--RG, E2, PG, SE, RC



Bearing

- Machine Tools / Robot
- Crossed Roller Bearing
 - Ballscrew Bearing
 - Linear Bearing
 - Support Unit



DATORKER®

Strain Wave Gear

- Robot / Automation Equipment / Semiconductor Equipment / Machine Tools
- DSC-P0 Type
 - DSC-C0 Type
 - DSH-PH Type
 - DSH-AH Type



AC Servo Motor & Drive

- Semiconductor / Packaging Machine / SMT / Food Industry / LCD
- Drives--D1, D2T/D2T-LM, E1
 - Motors--50W-2000W



Medical Equipment

- Hospital / Rehabilitation Centers / Nursing Homes
- Robotic Gait Training System
 - Robotic Endoscope Holder



Linear Motor Stage

- Automated Transport / AOI Application / Precision / Semiconductor
- Iron-core Linear Motor
 - Coreless Linear Motor
 - Linear Turbo Motor LMT
 - Planar Servo Motor
 - Air Bearing Platform
 - X-Y Stage • Gantry Systems
 - Single-Axis Linear Motor Stage



Torque Motor & Direct Drive Motor

- Machine Tools
- Torque Motor--TM-2/IM-2, TMRW Series
- Inspection / Testing Equipment / Robot
- Direct Drive Motor--DMS, DMY, DMN, DMT Series

HIWIN®

Ball Spline

Information Index

1. Introduction of Ball Splines	2
2. Description of ball spline specifications	5
3. Selecting procedure of ball spline	6
3.1 Diagram of the procedure for selecting the ball spline	6
3.2 Strength design of the spline shaft	7
3.3 Predicting life	13
4. Selecting preload	19
4.1 Conditions and benchmarks for use in the selection of preload	20
5. Selecting accuracy	21
5.1 Linear ball splines	21
5.2 Compound ball splines	24
6. Dimensions of the ball spline	25
6.1 Linear ball spline RS, FS, FSR types	25
6.2 Compound ball spline FBR, FBL types	27
7. Design examples	28
7.1 Inspection manual for the spline shaft design	28
7.2 Position of the keyway and flange hole of the spline nut	29
8. Installation steps	30
9. Option of ball spline	32
10. Precautions for use	33

1. Introduction of Ball Splines

Linear ball splines

(1) Cylinder type (RS type)



(2) Flange type (FS type)



(3) Rotary type (FSR type)

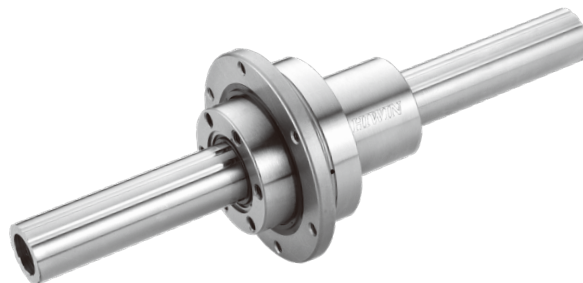

Product structure

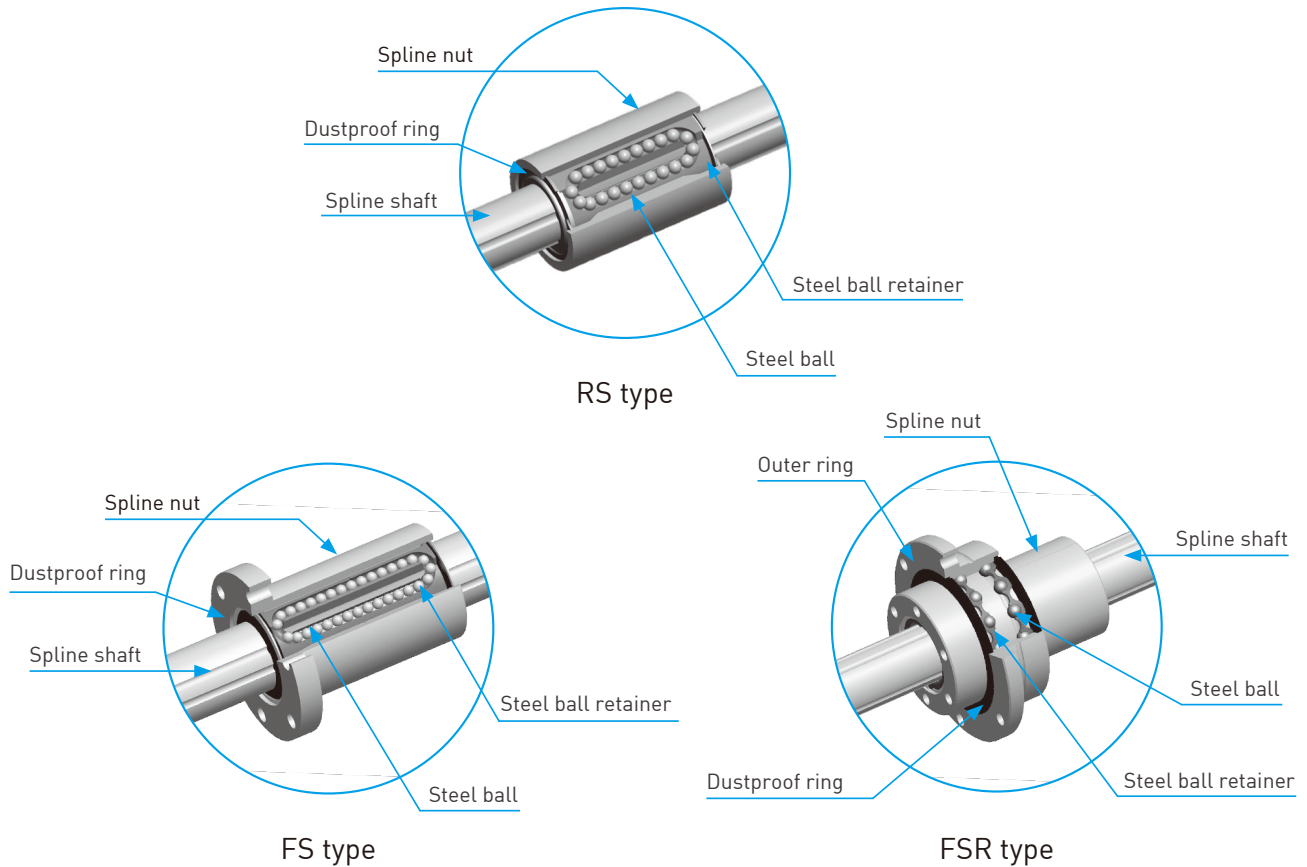

Figure 1-1. Product structure diagram of the linear ball spline

Features

The HIWIN ball spline is a rolling guide component consisting of a spline nut, a spline shaft, steel balls and a retainer. Rolling the steel balls in an infinite rolling cycle between the spline nut and the spline shaft allows the spline nut to move linearly along the spline shaft with high precision. The steel ball on the ball spline is of angular contact structure and can withstand radial loads and torsional loads. The spline nut and the outer ring are designed as all-in-one, which enables the ball spline to achieve a simplified structure.

The ball spline is equipped with 3 sets of balls in a face-to-face angular contact design. The balls are continuously moved in a complete cycle by means of a steel ball retainer. The optimized design of the retainer enables the guidance with high speed, high acceleration and deceleration. In addition, the encapsulation of the ball by the retainer makes it possible to withdraw the spline nut from the spline shaft without the balls falling out.

- **Transmittable torque capacity**

Compared with linear bearings, the ball in the rolling groove is in angular contact, so the spline nut and the spline shaft can move in relation to each other to achieve the function of transmitting torque.

- **All-in-one structure**

The spline nut and the outer ring are made in all-in-one structure to achieve high precision and compact design.

- **Easy to install**

The ball spline retainer prevents the balls from falling out even if the spline shaft is removed from the spline nut.

- **Lubricant circuit**

By optimizing the design of the lubricant circuit, the lubrication grease is directed to where the balls circulation to improve the lubrication effect and increase the service life.

Compound ball splines

- Ball screw spline (FBR type)

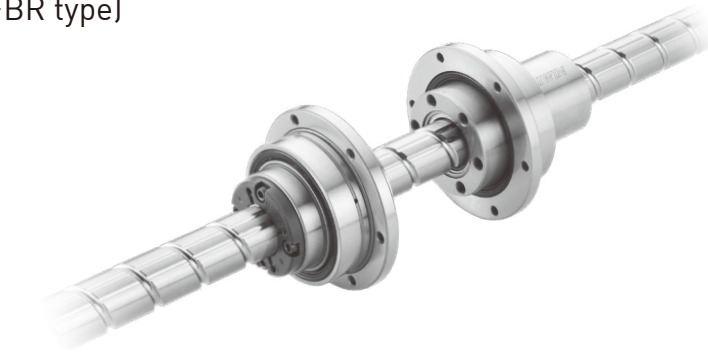

Product structure

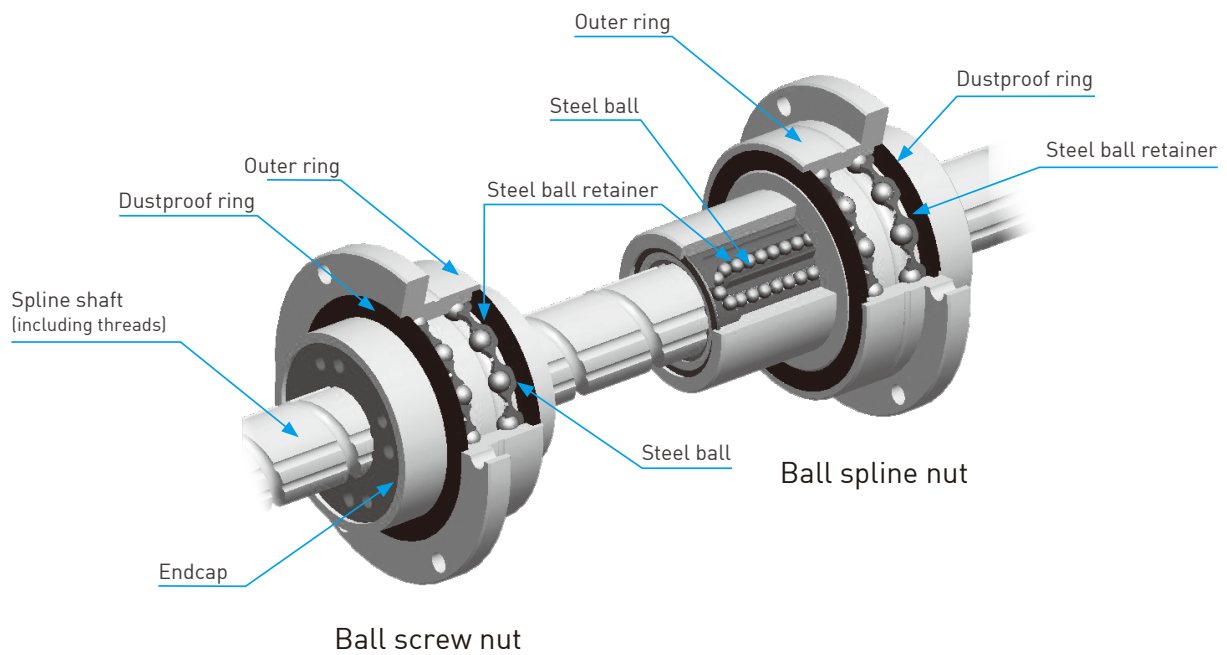

Figure 1-2. Product structure diagram of the compound ball spline

Features

The compound ball spline consists of a ball spline nut, a ball screw nut, a spline shaft, steel balls and retainers. Through the interaction of the two nuts on the spline, three modes of operation (linear, rotary and spiral), can be integrated on one shaft.

2. Description of ball spline specifications

Description of specifications - RS, FS, FSR

SP - 20 - 2 FS - 400 - 500 - C - S

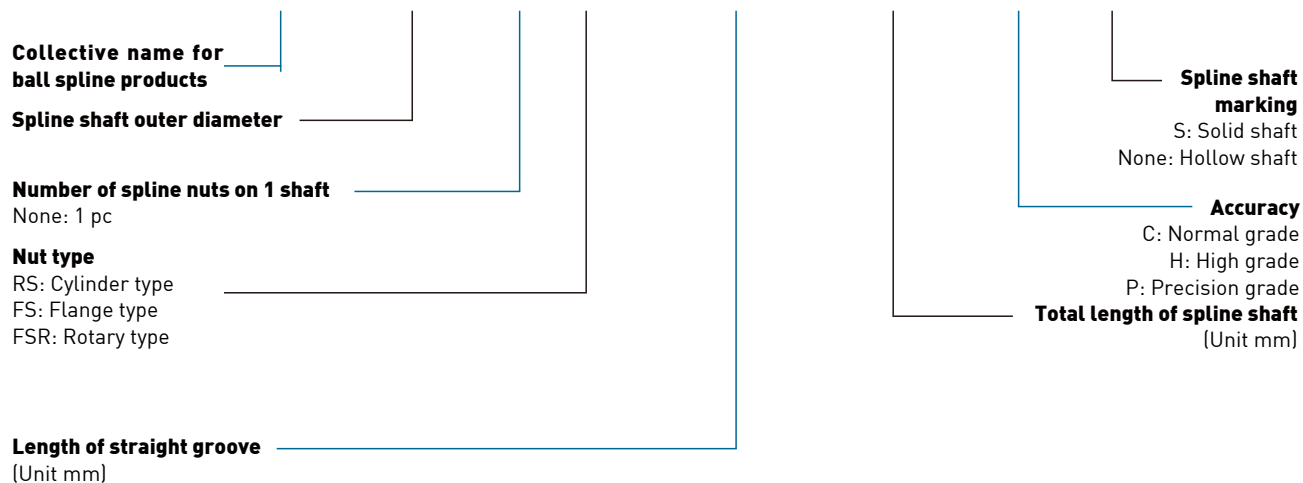

Description of specifications - FBR, FBL

SP - 20 - FBR - 400 - 500 - S

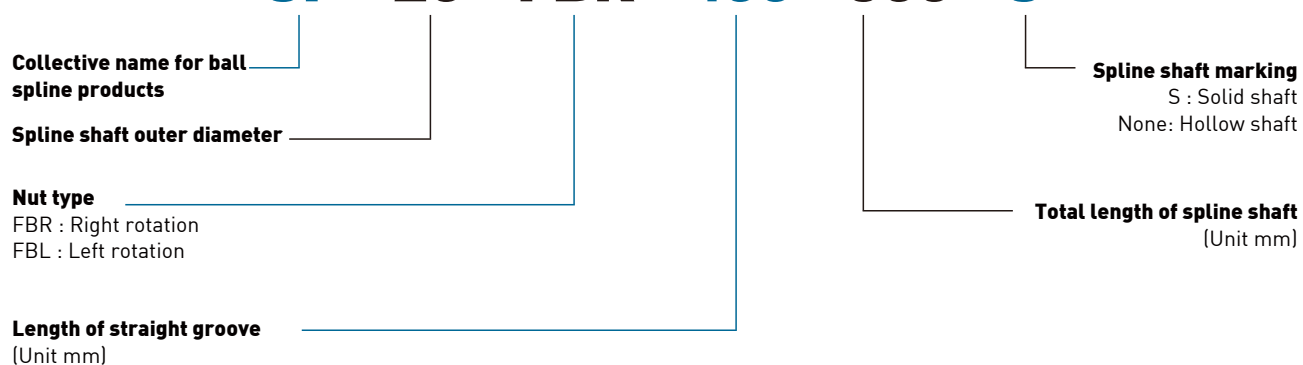

3. Selecting procedure of ball spline

3.1 Diagram of the procedure for selecting the ball spline

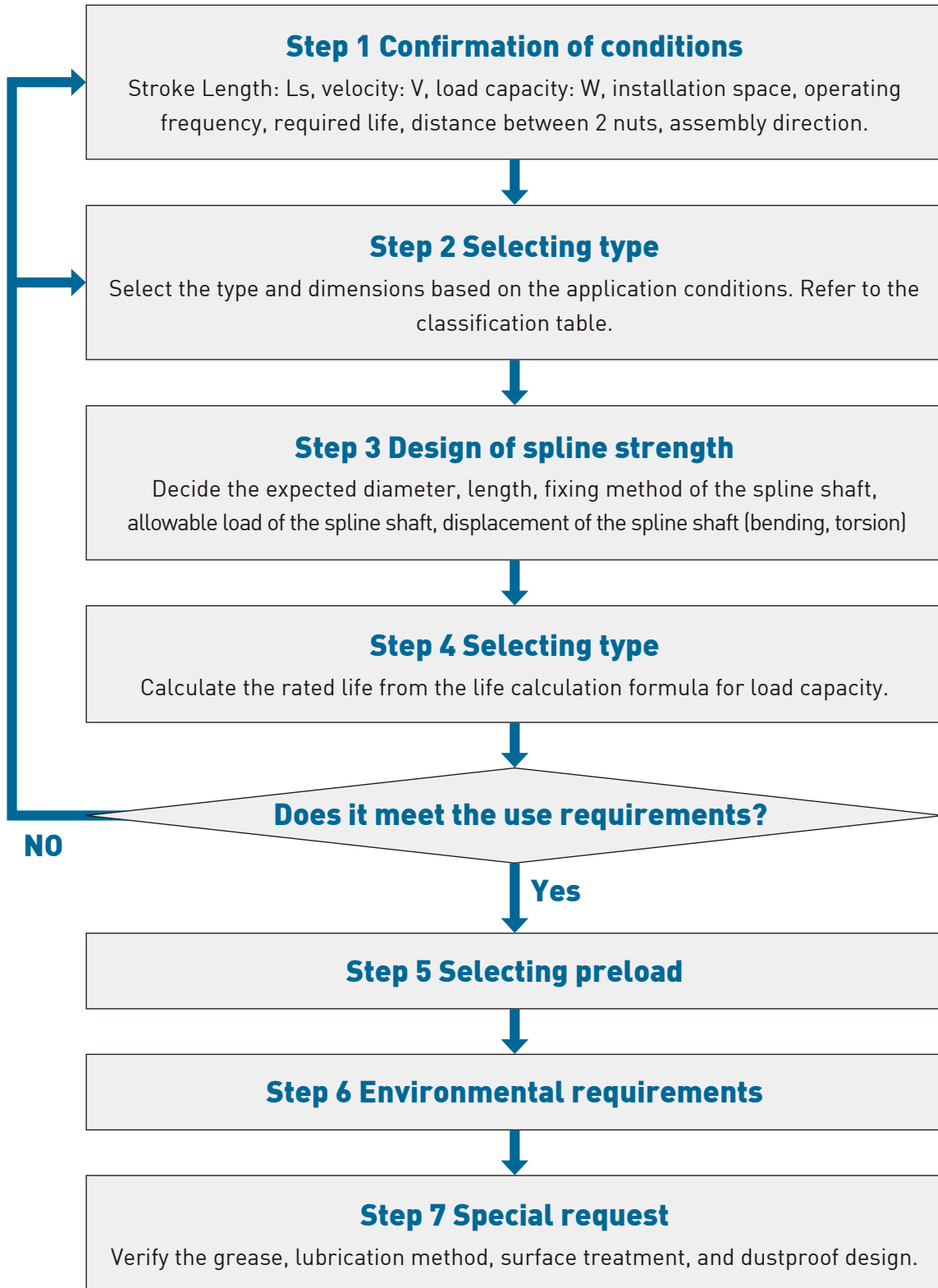

3.2 Strength design of spline shaft

The ball spline shaft is a composite shaft capable of withstanding radial loads and torsions. In case of high loads or torsions, it is necessary to take into account the strength of the spline shaft.

Spline shaft subjected to bending

When bending moments act on the spline shaft of the ball spline, the most suitable spline diameter can be calculated according to the following formula (1).

$$\mathbf{M} = \boldsymbol{\sigma} \cdot \mathbf{Z} \text{ and } \mathbf{Z} = \frac{\mathbf{M}}{\boldsymbol{\sigma}} \dots\dots\dots 1$$

M : Maximum bending moment acting on spline shaft (N-mm)

σ : Allowable bending stress of spline shaft (98N/mm²)

Z : Section modulus of the spline shaft (5.77x10² mm³ for specification SP20)

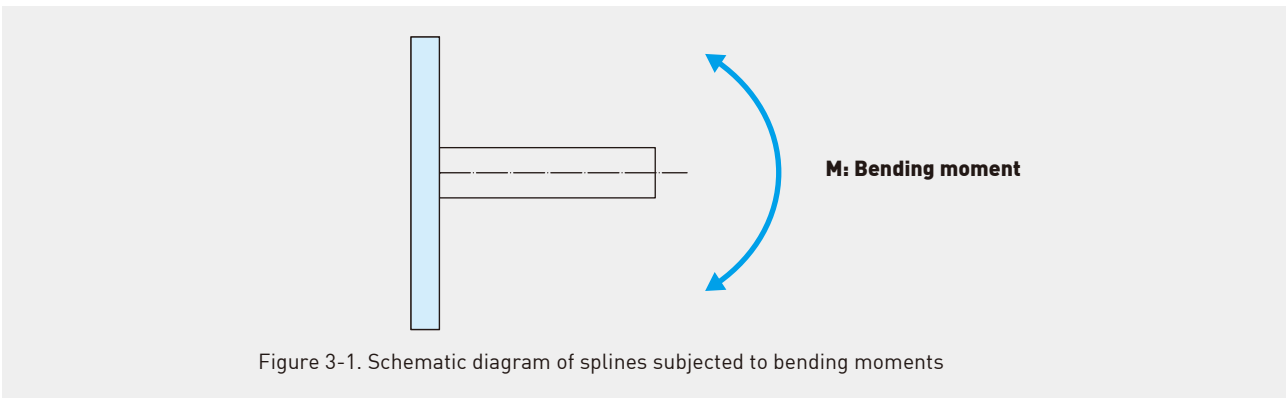

Spline shaft subjected to torsion

When torsions act on the ball spline shaft, the most suitable spline diameter can be calculated according to the following formula (2).

$$\mathbf{T} = \boldsymbol{\tau}_a \cdot \mathbf{Z}_p \text{ and } \mathbf{Z}_p = \frac{\mathbf{T}}{\boldsymbol{\tau}_a} \dots\dots\dots 2$$

T = Maximum torque acting on spline shaft (N-mm)

τ_a = Allowable torsion stress of spline shaft (49N/mm²)

Z_p = Polar section modulus of the spline shaft (specification 20 is 1.15 x 10³ mm³)

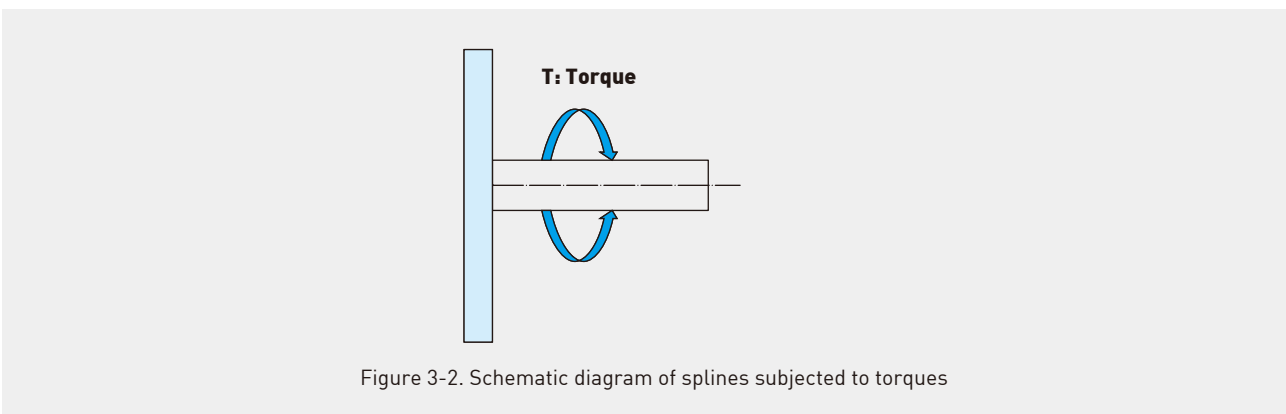

Spline shaft subjected to bending and torsion simultaneously

When the spline shaft of a ball spline is subjected to both bending moment and torque, the diameter of the spline shaft shall be calculated separately, with the equivalent bending moment (M_e) and equivalent torque (T_e) taken into account and the larger outer diameter of the spline shaft is taken as the diameter of the spline shaft.

Equivalent bending moment:

$$M_e = \frac{M + \sqrt{M^2 + T^2}}{2} = \frac{M}{2} \left\{ 1 + \sqrt{1 + \left(\frac{T}{M}\right)^2} \right\} \dots\dots\dots 3$$

$$M_e = \sigma \cdot Z$$

Equivalent torque:

$$T_e = \sqrt{M^2 + T^2} = M \times \sqrt{1 + \left(\frac{T}{M}\right)^2} \dots\dots\dots 4$$

$$T_e = \tau_a \cdot Z_p$$

Stiffness of the spline shaft

Stiffness of the spline shaft is indicated by the torsional angle of the spline shaft of length 1 m, which is limited to about 0.25°.

$$\theta = 57.3 \times \frac{T \cdot L}{G \cdot I_p} \dots\dots\dots 5 \quad \text{Stiffness of the spline shaft} = \frac{\text{Torsional angle}}{\text{Unit length}} = \frac{\theta \cdot 1000}{L} < \frac{1}{4}$$

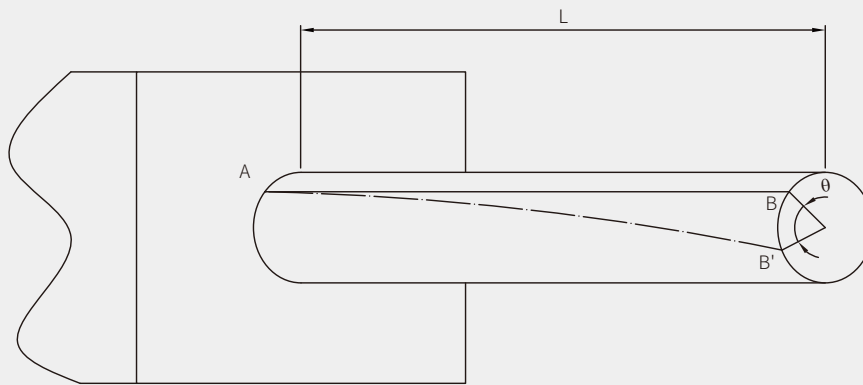

Figure 3-3. Schematic diagram of stiffness of the spline shaft

θ : Torsional angle (°)

L : Length of spline shaft (mm)

G : Transverse elastic modulus (7.9x10⁴N/mm²)

l : Unit length(1000mm)

I_p : Polar moment of inertia (specification 20 is 1.1⁴x10⁴mm⁴)

Deflection and deflection angle of the spline shaft

The calculation table of the Deflection and deflection angle of the spline shaft of the ball spline is based on the calculation formula suitable for its stress conditions.

Table 3-1. Calculation of Deflection and deflection angle

Support method	Conditions of use	Calculation formula of deflection	Calculation formula of deflection angle
Both ends are free		$\delta_{max} = \frac{Pl^2}{48EI}$	$i_1 = 0$ $i_2 = \frac{Pl^2}{16EI}$
Both ends are fixed		$\delta_{max} = \frac{Pl^3}{192EI}$	$i_1 = 0$ $i_2 = 0$
Both ends are free		$\delta_{max} = \frac{5pl^4}{384EI}$	$i_2 = \frac{pl^3}{24EI}$
Both ends are fixed		$\delta_{max} = \frac{pl^4}{384EI}$	$i_2 = 0$

Table 3-2. Calculation of Deflection and deflection angle

Support method	Conditions of use	Calculation formula of deflection	Calculation formula of deflection angle
Either end is fixed		$\delta_{max} = \frac{Pl^3}{3EI}$	$i_1 = \frac{Pl^2}{2EI}$ $i_2 = 0$
Either end is fixed		$\delta_{max} = \frac{pl^4}{8EI}$	$i_1 = \frac{pl^3}{6EI}$ $i_2 = 0$
Neither end is fixed		$\delta_{max} = \frac{\sqrt{3}M_0l^2}{216EI}$	$i_1 = \frac{M_0l}{12EI}$ $i_2 = \frac{M_0l}{24EI}$
Both ends are fixed		$\delta_{max} = \frac{M_0l^2}{216EI}$	$i_1 = \frac{M_0l}{16EI}$ $i_2 = 0$

δ_{max} : Maximum deflection (mm)

i_2 : Deflection angle at support point

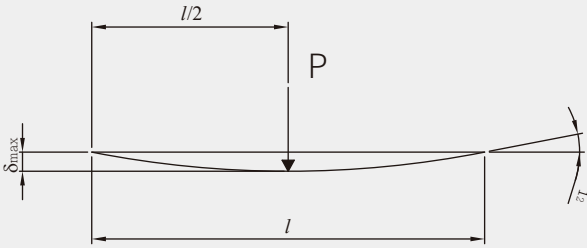
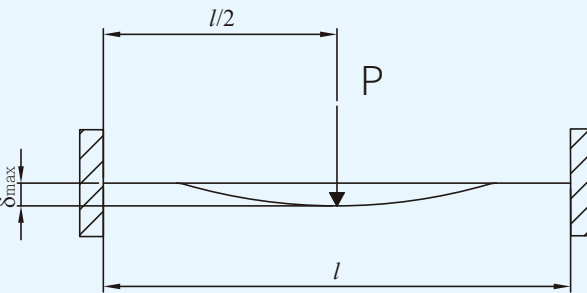
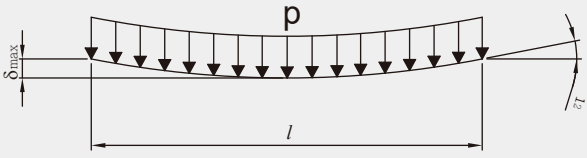
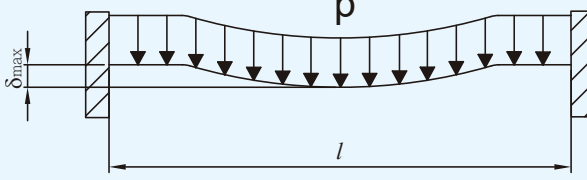
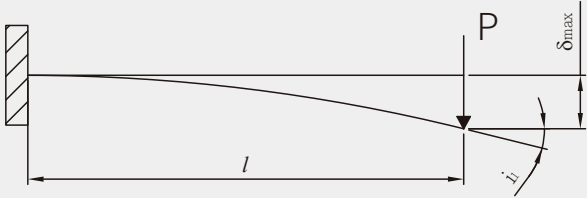
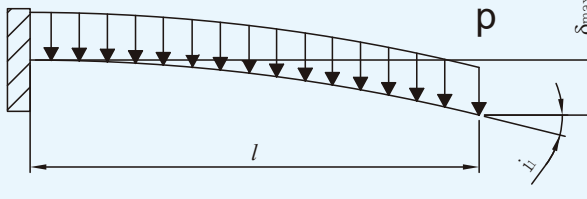
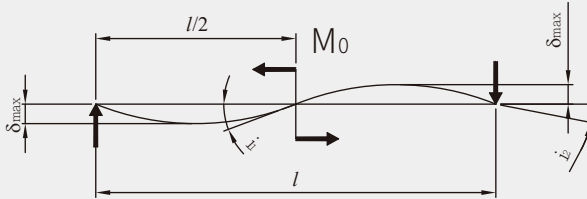
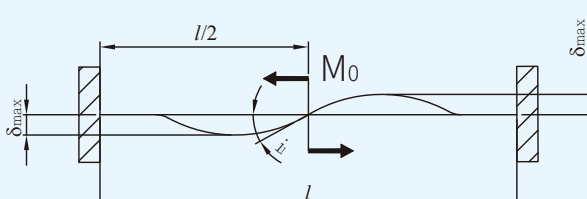
M_0 : Torque (N-mm)

P : Concentrated load(N)

l : Span (mm)

p : Uniform load(N/mm)

I : Geometric moment of inertia (mm⁴)

E : Young's modulus 2.06x10⁵(N/mm²)

i_1 : Deflection angle at support point

Cross-section characteristics of spline shafts

Table 3-3. Characteristics of the spline shaft cross-section

Nominal diameter		I: Geometrical moment of inertia mm ⁴	Z: Modulus section mm ³	I _p : Polar moment of inertia mm ⁴	Z _p : Polar section modulus mm ³
13	Solid shaft	1.32 x 10 ³	2.09 x 10 ²	2.7 x 10 ³	4.19 x 10 ²
	Hollow shaft	1.29 x 10 ³	2.0 x 10 ²	2.63 x 10 ³	4.09 x 10 ²
16	Solid shaft	3.09x10 ³	3.90x10 ²	6.18x10 ³	7.80x10 ²
	Hollow shaft	2.37x10 ³	2.99x10 ²	4.74x10 ³	5.99x10 ²
20	Solid shaft	7.61x10 ³	7.67x10 ²	1.52x10 ⁴	1.53x10 ³
	Hollow shaft	5.72x10 ³	5.77x10 ²	1.14x10 ⁴	1.15x10 ³
25	Solid shaft	1.86x10 ⁴	1.50x10 ³	3.71x10 ⁴	2.99x10 ³
	Hollow shaft	1.34x10 ⁴	1.08x10 ³	2.68x10 ⁴	2.16x10 ³
32	Solid shaft	5.01x10 ⁴	3.15x10 ³	9.90x10 ⁴	6.27x10 ³
	Hollow shaft	3.64x10 ⁴	2.29x10 ³	7.15x10 ⁴	4.53x10 ³

Critical velocity of the spline shaft

When the ball spline shaft is rotated by the transmitting power, if the rotation speed of the spline shaft increases to approach the resonance point, the spline will be in vibration. Therefore, the maximum rotation speed must be limited below the critical velocity without resonance. The critical velocity can be obtained from the following formula (6). (The safety coefficient is considered to be 0.8.) Above the resonance point, or in case of use near the resonance point, the diameter of the spline shaft must be reviewed.

• Critical velocity

$$N_c = \frac{60\lambda^2}{2\pi \times l_b^2} \times \sqrt{\frac{E \times 10^3 \times I}{\gamma \times A}} \times 0.8 \quad \dots \dots \dots \quad 6$$

N_c : Critical velocity(min⁻¹)

l_b : Distance between installation surfaces (mm)

E : Young's modulus (2.06x10⁵ N/mm²)

I : Minimum geometric moment of inertia of the shaft(mm⁴)

$$I = \frac{\pi d^4}{64} \quad d = \text{Small diameter (mm)}$$

γ : Density (specific center of gravity)
(7.85x10⁵kg/mm³)

$$A = \frac{\pi}{4} d^2 \quad d: \text{Small diameter (mm)}$$

A : Cross-section area of the end face of the spline shaft (mm²)

λ : Dependent on the installation method

1. Fixed - free, λ = 1.875, as in Figure 2-4.1.
2. Supported - Supported, λ = 3.142, as in Figure 2-4.2.
3. Fixed - Supported, λ = 3.927, as in Figure 2-4.3.
4. Fixed - Fixed, λ = 4.73, as in Figure 2-4.4.

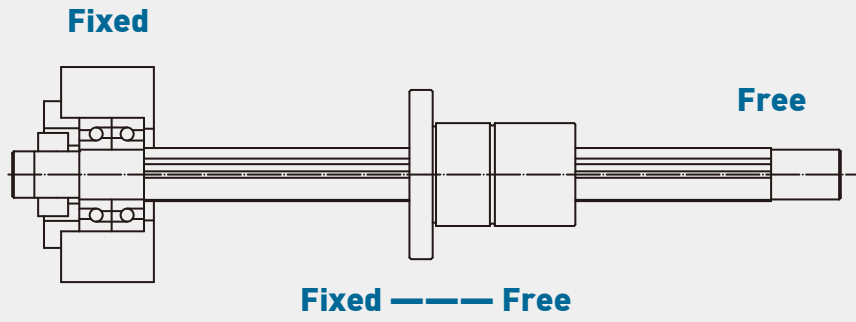

Figure 3-1. Schematic diagram of spline shaft fixed - free

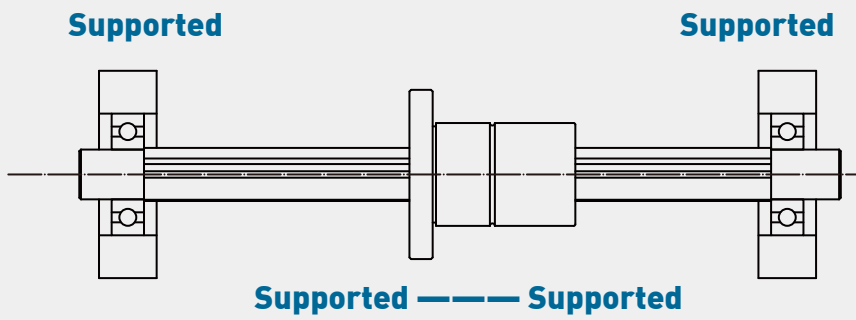

Figure 3-2. Schematic diagram of spline shaft supported - supported

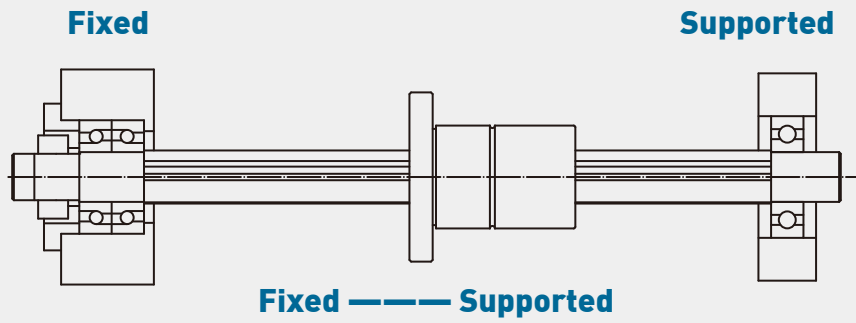

Figure 3-3. Schematic diagram of spline shaft fixed - supported

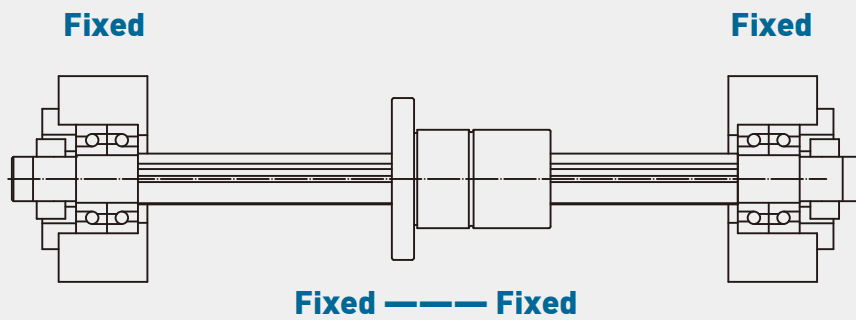

Figure 3-4. Schematic diagram of spline shaft fixed - fixed

3.3 Predicting life

Rated life

The life of a ball spline can vary considerably even if it is manufactured from the same batch and used under the same motion conditions. Therefore, as a basis for calculating the life of a linear motion system, use the rated life as defined below.

The rated life is the total running distance that can be achieved by having a batch of identical linear motion systems moving separately under the same conditions, 90% of which do not show metal fatigue.

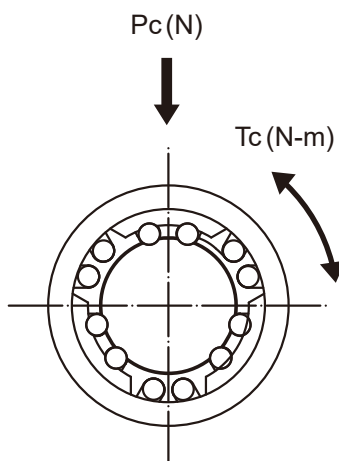

Figure 3-5. Schematic diagram of the ball spline subjected to stress

The ball spline can withstand three types of load during operation, torque load, radial load and moment load. The respective rated life can be obtained according to formula (7) to (10). (The basic rated load in each direction of load is recorded in the dimension table of each model number.)

- **When subjected to torque load**

$$L = \left(\frac{f_T \cdot f_C}{f_W} \times \frac{C_T}{T_C} \right)^3 \times 50 \dots\dots\dots 7$$

- **When subjected to radial load**

$$L = \left(\frac{f_T \cdot f_C}{f_W} \times \frac{C}{P_C} \right)^3 \times 50 \dots\dots\dots 8$$

L : Rated life (km)

C_T: Basic dynamic torque load rating (N-m)

T_C: Calculated value of applied torque (N-m)

C : Basic dynamic load rating (N)

P_C : Calculated value of radial load (N)

f_T : Temperature coefficient (see the figure 3-6)

f_C : Contact coefficient (see the table 3-4)

f_W : Load coefficient (see the table 3-5)

• **When subjected to both torque load l and radial loads simultaneously**

When subjected to both torque load and radial loads simultaneously, the equivalent radial load can be calculated according to the following formula (9) and then the life can be calculated.

$$P_E = P_C + \frac{4 \cdot T_c \times 10^3}{i \cdot dp \cdot \cos\alpha} \dots\dots\dots 9$$

P_E : Equivalent radial load (N)

$\cos\alpha$: Contact angle (FBR type $\alpha=70^\circ$)

i : 3 rows of steel balls under load for specification 20

dp : Ball center diameter (mm)

• **Calculating life time**

After calculating the rated life (L) using the above formula, the life time can be calculated according to the following formula (10) when the number of strokes and times are fixed.

$$L_h = \frac{L \times 10^3}{2 \times l_s \times n_1 \times 60} \dots\dots\dots 10$$

L_h : Life time (h)

l_s : Stroke length (m)

n_1 : Cycles per minute (min^{-1})

f_T : Temperature coefficient

When using a ball spline in operating temperatures exceeding 100°C, multiply the temperature coefficient of Figure 3-6 when calculating the life, taking into account the adverse effects caused by high temperatures. Also, note that it is necessary to use ball spline products suitable for high temperatures.

Note: In case of operating above 80°C, the material of the dustproof ring and retainer must be changed to a material for the high-temperature specification accordingly.

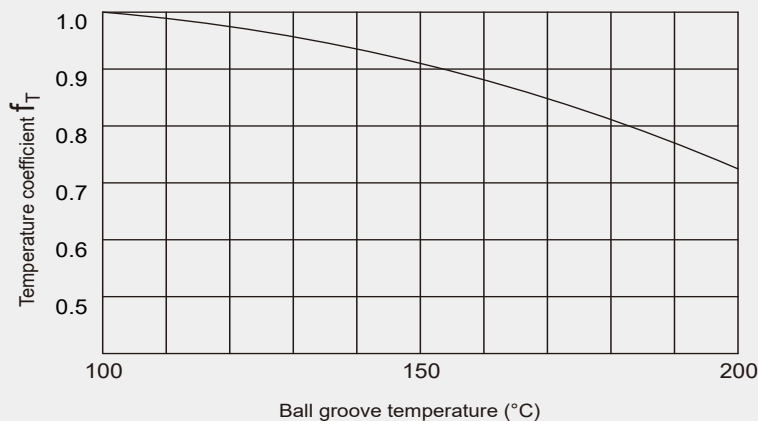

Figure 3-6. Temperature coefficient (f_T)

f_c : Contact coefficient

When multiple nuts are mounted closely and working in linear motion, it is difficult to get a uniform distributions of loads due to the moment load and mounting accuracy. Therefore when using multiple nuts closely, multiply the basic load rating(C) and (C0) by corresponding contact coefficients in Table 3-4.

Table 3-4. Contact coefficient (f_c)

Number of spline nut mounted closely	Contact coefficient f_c
2	0.81
3	0.72
4	0.66
5	0.61
Usual use	1

Note: If the load is expected to be nonuniform in large installations, please refer to the contact coefficients in Table 3-4.

f_w : Load coefficient

Most machines will have vibration and impact during operation. It's very difficult to calculate correctly, especially for vibration is generated during high-speed movement or impact is caused by frequent starting and stopping. Therefore, when the actual load on the linear motion system is not available, or when the effects of velocity and vibration are significant, please divide the basic load rating (C) and (C0) by the load coefficients obtained from experience in Table 3-5.

Table 3-5. Loadcoefficient (f_w)

Vibration/impact	Velocity V (m/s)	Load coefficient f_w
Low	Mini speed per hour $V \leq 0.25$	1~1.2
Small	At low speed $0.25 < V \leq 1$	1.2~1.5
Medium	At medium speed $1 < V \leq 2$	1.5~2
High	At high speed $V > 2$	2~3.5

Shape of the spline shaft cross-section

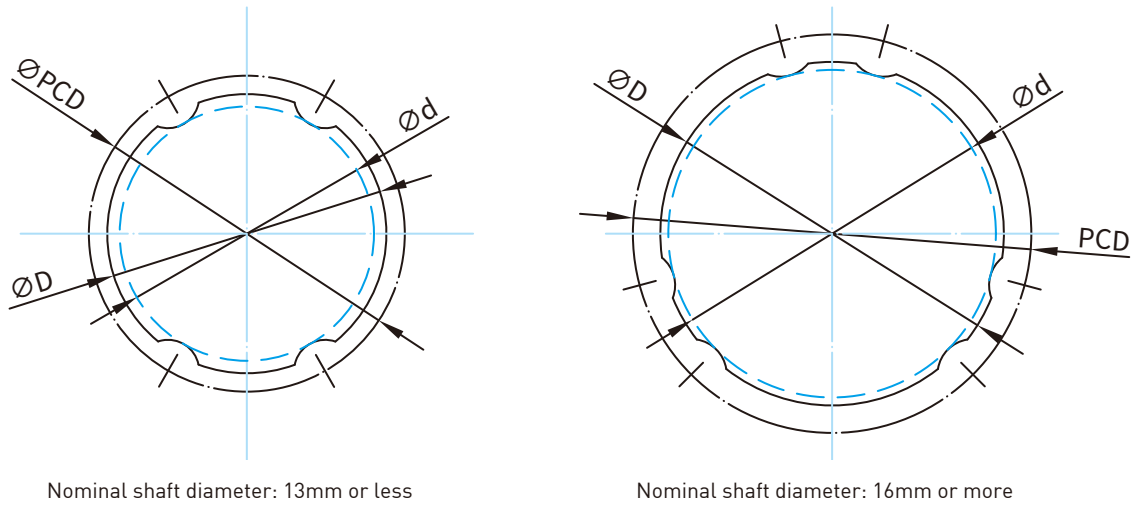

Figure 3-7. Diagram of the ball spline cross-section

Shape of the hollow spline shaft cross-section

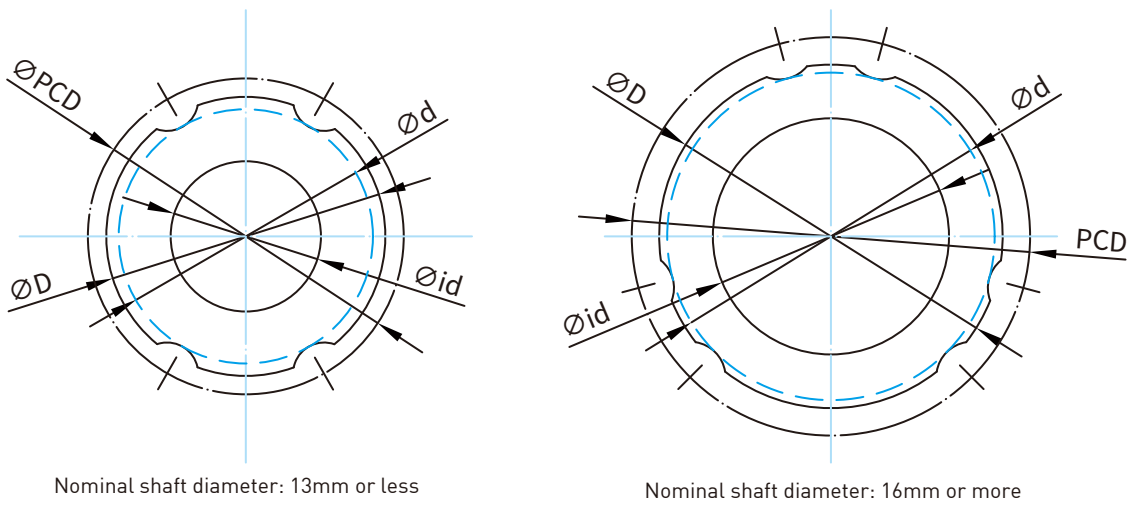

Figure 3-8. Diagram of the hollow ball spline cross-section

Table 3-6. Parameters of the spline shaft cross-section

Unit: mm

Nominal shaft diameter	13	16	20	25	32
Groove valley diameter ϕd	12.02	15.02	18.92	23.62	30.42
Ball center PCD	14.8	17.8	22.1	27.6	33.2
Outer diameter ϕD	13	16	20	25	32
Allowable outer diameter tolerance	0 -0.018		0 -0.021		
Hollow hole ϕid	7	11	14	18	23

* The groove valley diameter ϕd must be the value where no groove is left after processing.

Calculating average load

When the load on the spline nut varies, as in the case of the industrial robots with a work piece when moving forward and has its arm weight only when moving backward, it is necessary to calculate the life considering the conditions of variation of the load.

Average load (P_m) is a certain load that has the same life as the life under the conditions of this variable load when the load acting on the spline nut varies with various motion conditions.

The basic formula is shown below:

$$P_m = \sqrt[3]{\frac{1}{L} \cdot \sum_{n=1}^n (P_n^3 \cdot L_n)} \quad \dots\dots\dots 11$$

P_m : Average load (N)

P_n : Variable load (N)

L : Total running distance (mm)

L_n : Distance traveled during P_n

The case of step load

$$P_m = \sqrt[3]{\frac{1}{L} \cdot (P_1^3 \cdot L_1 + P_2^3 \cdot L_2 \dots\dots + P_n^3 \cdot L_n)} \quad \dots\dots\dots 12$$

P_m : Average load (N)

P_n : Variable load (N)

L : Total running distance (mm)

L_n : Distance traveled during P_n

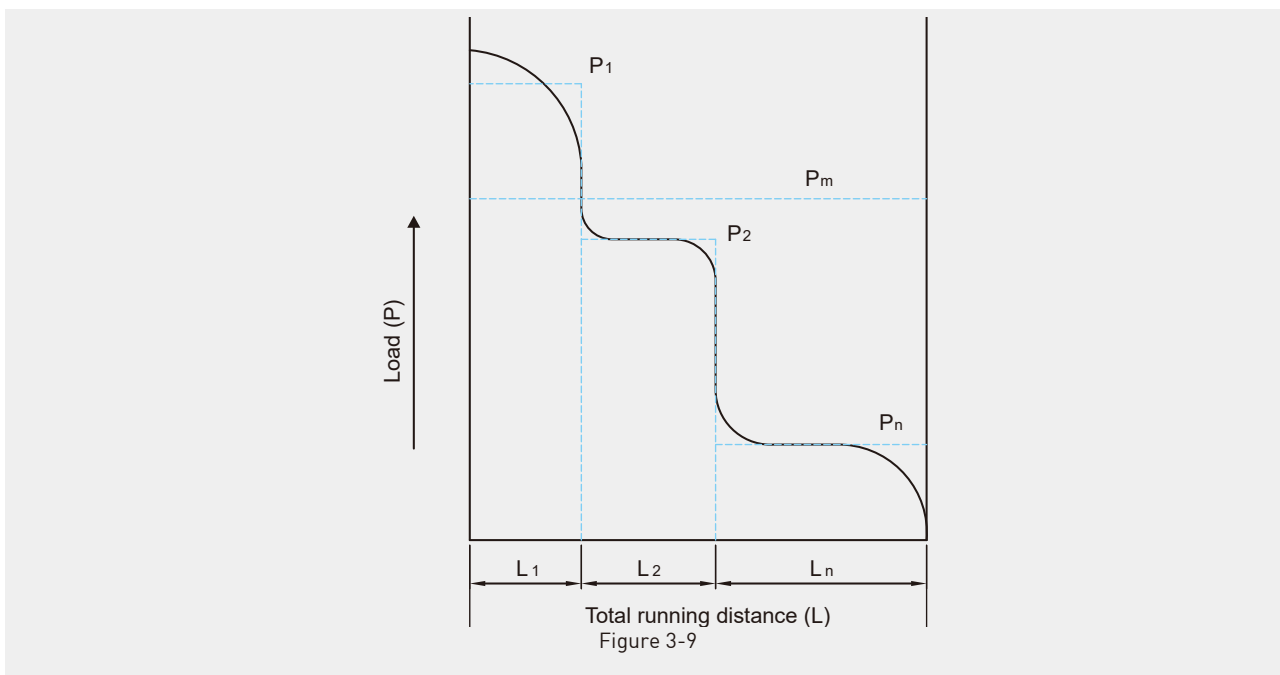

The case of linear variation

$$P_m \cong \frac{1}{3} (P_{min} + 2 \times P_{max})$$

13

P_{min} : Minimum load (N)

P_{max} : Maximum load (N)

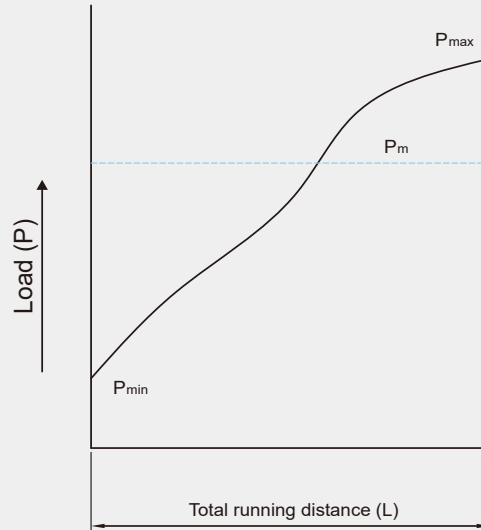

Figure 3-10

The case of sinusoidal loading

(a) $P_m \cong 0.65 \times P_{max}$

14

(b) $P_m \cong 0.75 \times P_{max}$

15

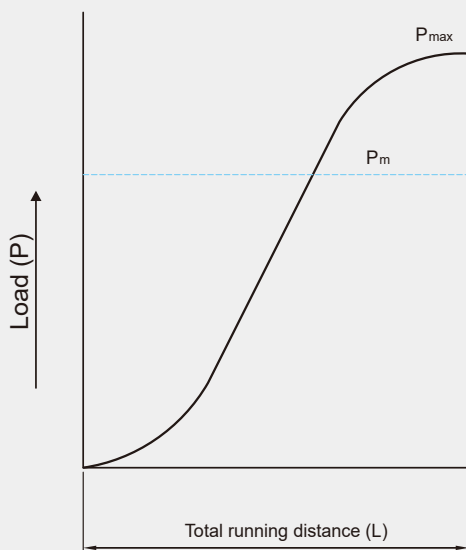

Figure 3-11

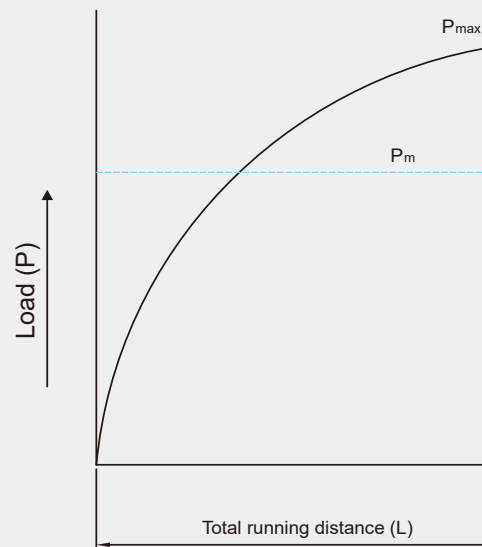

Figure 3-12

4. Selecting preload

The preload of the ball spline significantly influences accuracy, and stiffness, so it is necessary to select the appropriate clearance (or preload) for the application. Clearance values are specified for each model number and can therefore be selected appropriately according to the conditions of use.

Preload and stiffness

Preload is a load applied to the ball beforehand to eliminate clearance in the rotation direction and improve stiffness. When preload is applied, the ball spline increases stiffness according to the strength of the preload. Figure 4-1 shows the displacement in the direction of rotation when applying a rotational torsion.

As shown in Figure 4-1, the effect of preload is maintained up to 2.8 times the preload load. Compared with the time without preload, the displacement becomes one-half of the same torsion and the stiffness is more than 2 times.

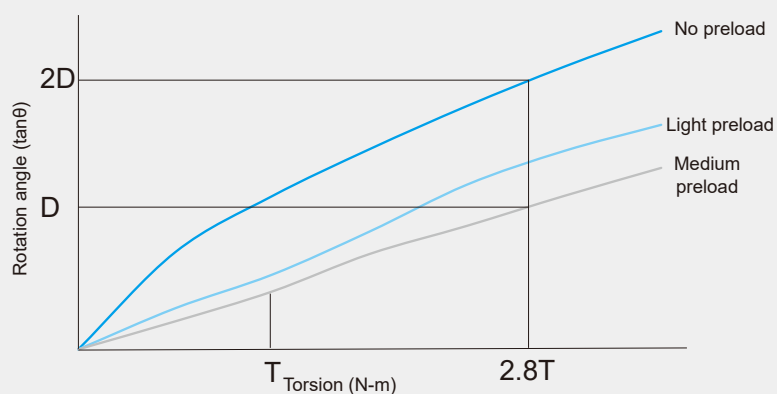

Figure 4-1

4.1 Conditions and benchmarks for use in the selection of preload

Table 4-1 indicates the benchmarks for selection of clearance in the direction of rotation according to the conditions of use of the ball spline.

Clearance in the direction of rotation of the ball spline significantly influences the accuracy or stiffness of the ball spline. Therefore, it is important to select the appropriate clearance according to the application. Generally, products with preload are used. There is a high vibration shock in the case of a repeated rotating motion or a reciprocating linear motion, so applying preload will significantly improve the stiffness and accuracy.

Table 4-1. Selected benchmark for clearance of the ball spline in the direction of rotation

Clearance in the direction of rotation	Conditions of use	Typical Applications
No preload	<ul style="list-style-type: none"> Where it is intended to drive smoothly with a small force Where the torsion always acts in a certain direction 	<ul style="list-style-type: none"> Various metering instruments Automatic drawing machine Shape measuring instruments Dynamometer Winding machine Automatic welding machine Boring and grinding machine main shaft Automatic packing machine
Light preload	<ul style="list-style-type: none"> Where the cantilever load or moment is applied Where high accuracy of repetition is required Where variable load is applied 	<ul style="list-style-type: none"> Rocker arm of industrial robots Various automatic loading and unloading machines Automatic coating guide shaft Electric discharge machine main shaft Stamping die guide shaft Drilling machine main shaft
Medium pre-load	<ul style="list-style-type: none"> Where high stiffness is required and vibration shock is prone to occur. Where a spline nut is subject to the moment 	<ul style="list-style-type: none"> The steering shaft of construction vehicles Paste welding machine shaft Automatic plate tool table indexing shaft

Table 4-2. Clearance and preload range for each specification in the direction of rotation.

Shaft diameter	No preload	Light preload	Medium preload
13	~	0~0.02C	0.05C~0.07C
16, 20	~	0~0.02C	0.05C~0.07C
25, 32	~	0~0.02C	0.05C~0.07C

* C indicates basic dynamic load rating

5. Selecting accuracy

5.1 Linear ball splines

Grade of accuracy

The grade of accuracy of the ball spline is expressed in terms of oscillation of the outer diameter of the spline nut against the supporting part of the spline shaft. It is divided into normal (C), high (H) and precision (P) which are shown in Figure 5-1.

Accuracy indication

- RS type

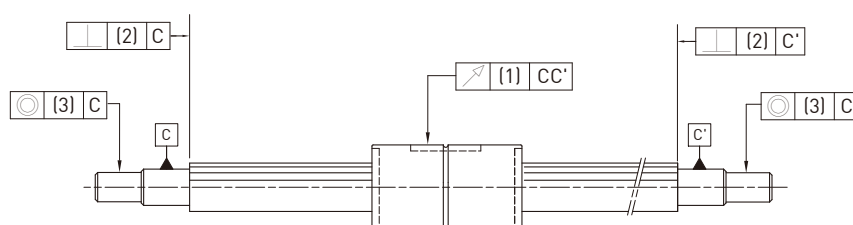

Figure 5-1. Measurement items of the accuracy of RS type ball spline

Table 5-1 Runout accuracy of RS type ball splines

Unit μm

Nominal shaft diameter		13			16			20			25			32			
		C	H	P	C	H	P	C	H	P	C	H	P	C	H	P	
Total length of spline shaft	Above																
	Below																
	-	200	56	34	18	56	34	18	56	34	18	53	32	18	53	32	18
	200	315	71	45	25	71	45	25	71	45	25	58	39	21	58	39	21
	315	400	83	53	31	83	53	31	83	53	31	70	44	25	70	44	25
	400	500	95	62	38	95	62	38	95	62	38	78	50	29	78	50	29
	500	630	112			112			112			88	57	34	88	57	34
	630	800										103	68	42	103	68	42
800	1000										124	83		124	83		

Table 5-2 Geometric accuracy of RS type ball splines

Unit μm

Accuracy	Shoulder verticality [2]			Shoulder concentricity [3]		
	C	H	P	C	H	P
Nominal shaft diameter						
13	27	11	8	46	19	12
16	27	11	8	46	19	12
20	27	11	8	46	19	12
25	33	13	9	53	22	13
32	33	13	9	53	22	13

• **FS type**

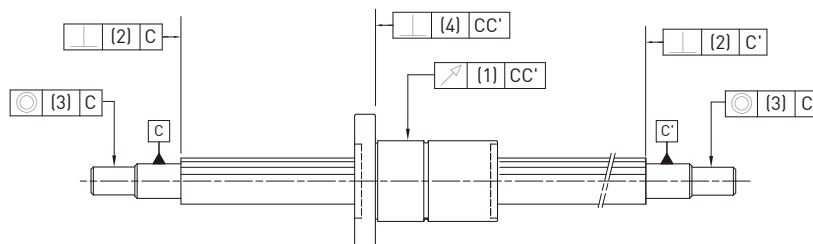

Figure 5-2. Measurement items of the accuracy of FS type ball spline

Table 5-3 Runout accuracy of FS type ball splines

Unit μm

Nominal shaft diameter		13			16			20			25			32		
Total length of spline shaft	Above	C	H	P	C	H	P	C	H	P	C	H	P	C	H	P
	-	200	56	34	18	56	34	18	56	34	18	53	32	18	53	32
200	315	71	45	25	71	45	25	71	45	25	58	39	21	58	39	21
315	400	83	53	31	83	53	31	83	53	31	70	44	25	70	44	25
400	500	95	62	38	95	62	38	95	62	38	78	50	29	78	50	29
500	630	112			112			112			88	57	34	88	57	34
630	800										103	68	42	103	68	42
800	1000										124	83		124	83	

Table 5-4 Geometric accuracy of FS type ball splines

Unit μm

Accuracy	Shoulder verticality (2)			Shoulder concentricity (3)			Verticality (4)		
	C	H	P	C	H	P	C	H	P
13	27	11	8	46	19	12	39	16	11
16	27	11	8	46	19	12	39	16	11
20	27	11	8	46	19	12	39	16	11
25	33	13	9	53	22	13	39	16	11
32	33	13	9	53	22	13	39	16	11

• FSR type

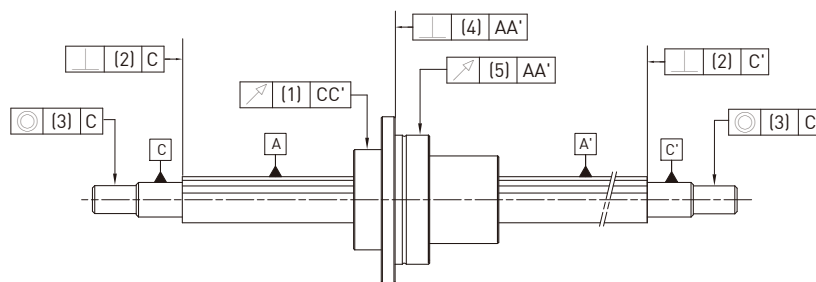

Figure 5-3. Measurement items of the accuracy of FSR type ball spline

Table 5-5 Runout accuracy of FSR type ball splines

Unit μm

Nominal shaft diameter		13			16			20			25			32		
Total length of spline shaft	Above	C	H	P	C	H	P	C	H	P	C	H	P	C	H	P
	-	200	56	34	18	56	34	18	56	34	18	53	32	18	53	32
200	315	71	45	25	71	45	25	71	45	25	58	39	21	58	39	21
315	400	83	53	31	83	53	31	83	53	31	70	44	25	70	44	25
400	500	95	62	38	95	62	38	95	62	38	78	50	29	78	50	29
500	630	112			112			112			88	57	34	88	57	34
630	800										103	68	42	103	68	42
800	1000										124	83		124	83	

Table 5-6 Geometric accuracy of FSR type ball splines

Unit μm

Nominal shaft diameter	Accuracy	Shoulder verticality (2)			Shoulder concentricity (3)			Outer ring verticality (4)			Outer ring runout (5)		
		C	H	P	C	H	P	C	H	P	C	H	P
16		27	11	8	46	19	12	29	18	13	32	21	16
20		27	11	8	46	19	12	29	18	13	32	21	16
25		33	13	9	53	22	13	32	21	16	32	21	16
32		33	13	9	53	22	13	32	21	16	32	21	16

5.2 Compound ball splines

Accuracy specifications

The compound ball spline consists of a ball screw nut and a ball spline nut, and is made according to the following specifications and inspected in accordance with Figure 5-4 and Table 5-6.

• Ball screw

Axial clearance: 0

Lead accuracy: C4 grade

• Ball spline

Clearance in the direction of rotation: 0 (light preload)

Precision grade: H grade

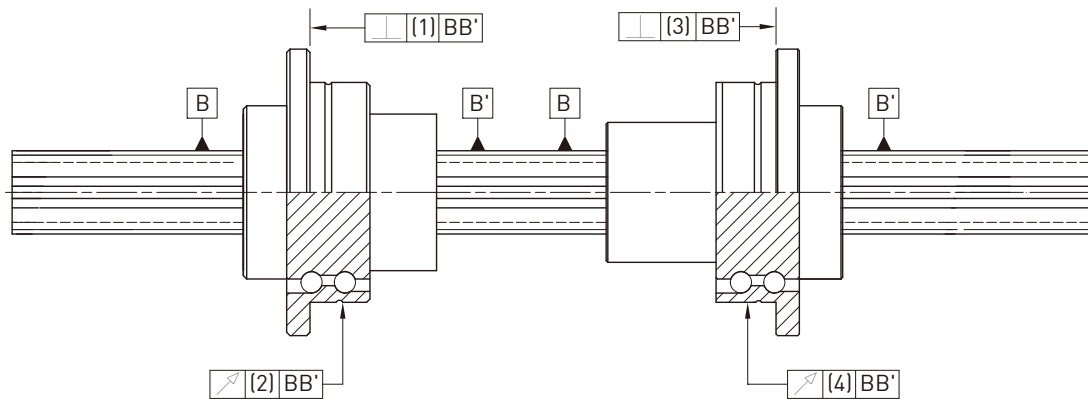

Figure 5-4. Measurement items of the accuracy of compound ball spline

Table 5-6. Table of geometric accuracy of the linear ball spline

Nominal shaft diameter	Ball screw nut		Ball spline nut		Unit μm
	Verticality (1)	Runout (2)	Verticality (3)	Runout (4)	
16	16	20	18	21	
20	16	20	18	21	
25	18	24	21	21	
32	18	24	21	21	

6. Dimensions of the ball spline

6.1 Linear ball spline RS, FS, FSR types

Product dimensions

• RS type

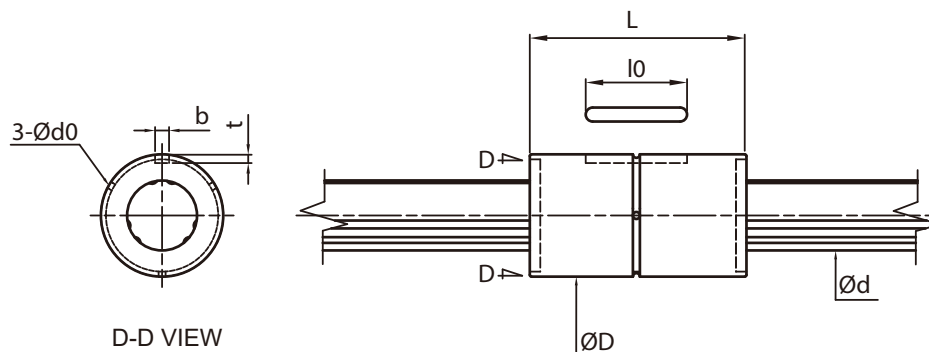

Nominal shaft diameter	Basic load rating		Basic torque load rating		Permission static moment	Outer diameter	Length	Keyway width	Keyway depth	Keyway length	Lubrication hole
	C (kN)	Co (kN)	C _T (N-m)	C _{oT} (N-m)	MA(N-m)	D	L	b H8	t +0.1 0	IO	d0
13	4.07	5.99	5.98	10.88	19.6	24	36	3	1.5	15	1.5
16	7.2	13.5	32.1	34.4	67.6	31	50	3.5	2	17.5	2
20	10.4	20.0	57.8	63.2	118	35	63	4	2.5	29	2
25	15.4	27.5	106.5	108.8	210	42	71	4	2.5	36	3
32	20.5	34.4	181.5	173.1	290	49	80	4	2.5	42	3

• FS type

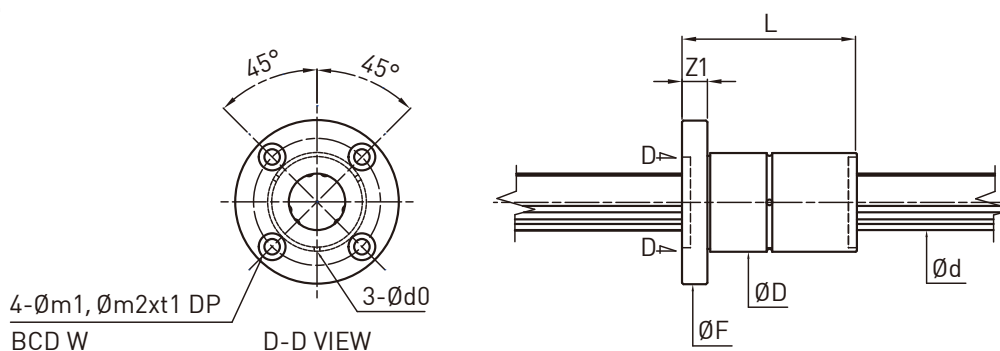

Nominal shaft diameter	Basic load rating		Basic torque load rating		Permission static moment	Outer diameter	Flange outer diameter	Length	Z1	Lubrication hole	W	m1	m2x1
	C (kN)	Co (kN)	C _T (N-m)	C _{oT} (N-m)	MA(N-m)	D	F	L		d0			
13	4.07	5.99	5.98	10.88	19.6	24	44	36	7	1.5	33	4.5	8x4.4
16	7.2	13.5	32.1	34.4	67.6	31	51	50	7	2	40	4.5	8x4.4
20	10.4	20.0	57.8	63.2	118	35	58	63	9	2	45	5.5	9.5x5.4
25	15.4	27.5	106.5	108.8	210	42	65	71	9	3	52	5.5	9.5x5.4
32	20.5	34.4	181.5	173.1	290	49	77	80	10	3	62	6.6	11x6.5

• **FSR type**

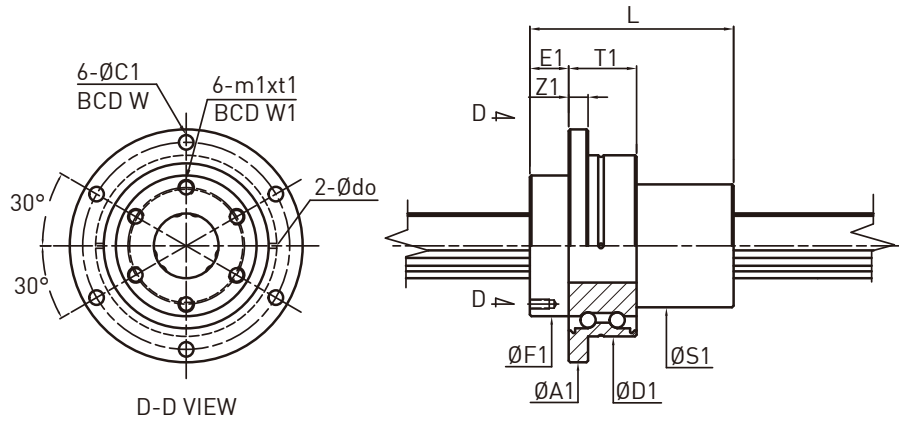

Nominal shaft diameter	Basic load rating		Basic torque load rating		Permission static moment	Outer diameter	Flange outer diameter	Total length	F1	S1	T1	E1	Z1	W	W1	m1xt1	C1	Lubrication hole		Support bearing basic load rating	
	C (kN)	Co (kN)	C _T (N-m)	C _{st} (N-m)														MA (N-m)	D	A1	L
16	7.2	13.5	32.1	34.4	67.6	48	64	50	36	31	21	10	6	56	30	M4x6	4.5	1.5	9.3	11.5	
20	10.4	20.0	57.8	63.2	118	56	72	63	43.5	35	21	12	6	64	36	M5x8	4.5	1.5	9.8	13.3	
25	15.4	27.5	106.5	108.8	210	66	86	71	52	42	25	13	7	75	44	M5x8	5.5	2.5	13.1	22	
32	20.5	34.4	181.5	173.1	290	78	103	80	63	52	25	17	8	89	54	M6x10	6.6	2.5	13.7	25.2	

6.2 Compound ball spline FBR, FBL types

Product dimensions

• FBR type

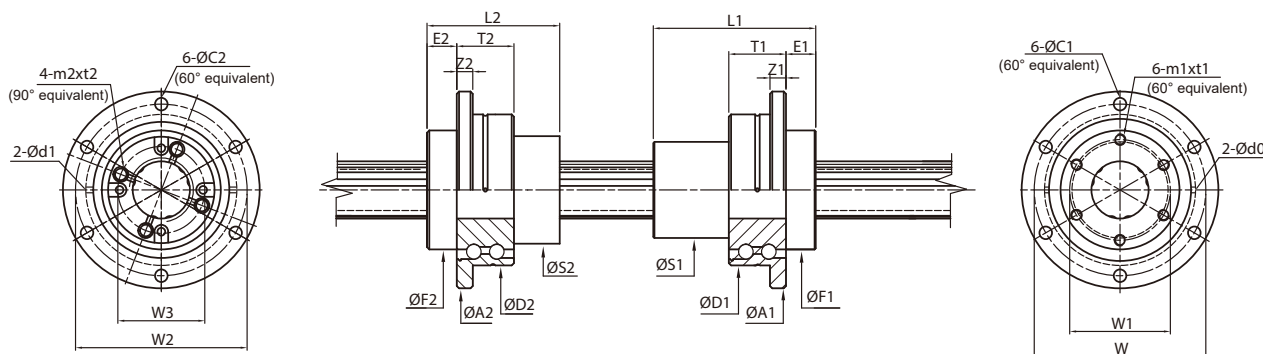

Model number	Specifications			Ball screw nut														Support bearing basic load rating		
	Nominal outer diameter	Nominal inner diameter	Lead	Basic load rating		Outer diameter D2 g6	Flange outer diameter A2	Total length L2	F2 h7	S2	T2	E2	Z2	W2	W3	m2x2	C2	Lubrication hole	Support bearing basic load rating	
				C(kN)	Co(kN)													d1	Ca(kN)	Coa(kN)
16	16	11	16	4.7	9.6	48	64	40	36	32	21	10	6	56	25	M4x8	4.5	1.5	9.3	11.5
20	20	14	20	6.4	14	56	72	46	43.5	40	21	11	6	64	31	M5x8	4.5	1.5	9.8	13.3
25	25	18	25	9.5	21.9	66	86	58	52	47	25	13	7	75	38	M6x12	5.5	2.5	13.1	22
32	32	23	32	13	29.8	78	103	72	63	58	25	14	8	89	48	M6x10	6.6	2.5	13.7	25.2

Model number	Ball spline nut																Support bearing basic load rating			
	Basic load rating		Basic torque load rating		Permission static moment	Outer diameter D1	Flange diameter A1	Total length L1	F1 h7	S1	T1	E1	Z1	W	W1	m1x1	C1	Lubrication hole	Support bearing basic load rating	
	C(kN)	Co(kN)	C _t (N·m)	C _r (N·m)														MA(N·m)	d0	Ca(kN)
16	7.2	13.5	32.1	34.4	67.6	48	64	50	36	31	21	10	6	56	30	M4x6	4.5	1.5	9.3	11.5
20	10.4	20.0	57.8	63.2	118	56	72	63	43.5	35	21	12	6	64	36	M5x8	4.5	1.5	9.8	13.3
25	15.4	27.5	106.5	108.8	210	66	86	71	52	42	25	13	7	75	44	M5x8	5.5	2.5	13.1	22
32	20.5	34.4	181.5	173.1	290	78	103	80	63	52	25	17	8	89	54	M6x10	6.6	2.5	13.7	25.2

7. Design examples

7.1 Inspection manual for the spline shaft design

For products that require the end machining of the spline shaft end, please check the following points when placing orders. The following Figure shows the basic drawing of the ball spline.

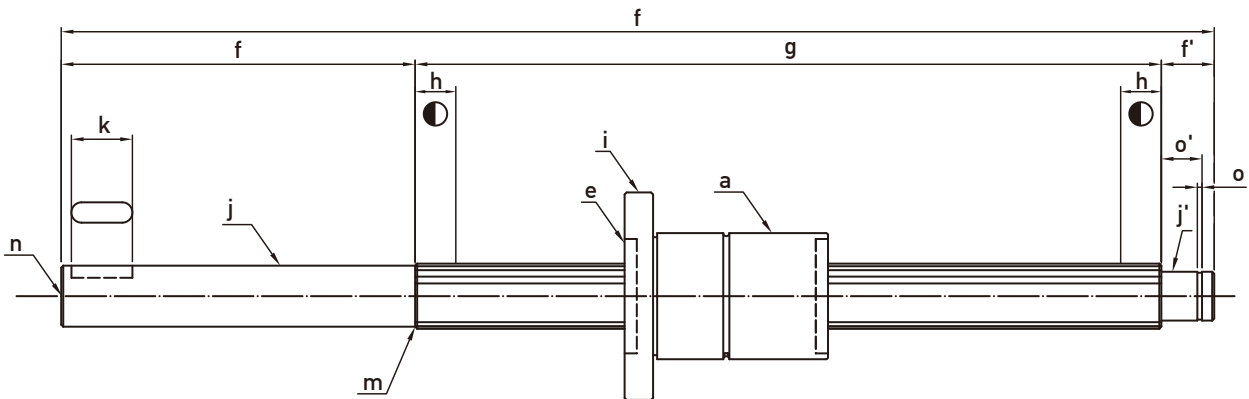

Figure 7-1. Basic drawing of the ball spline.

Inspection requirements

- a. Type of spline nut to be installed
- b. Number of spline nuts
- c. Clearance of rotating direction
- d. Accuracy
- e. With or without the dustproof ring
- f. Full length (whether the dimensions of all parts are ready and whether the total dimensions are correct)
- g. Effective length of the spline part
- h. Incomplete heat treatment area
- i. The direction of the flange (flange type)
- j. If spline shaft end part diameter is larger than stroke area.
- k. Position of the spline nut in relation to the shape of the spline shaft end (keyway of the spline nut, flange hole)
- l. Indication of the chamfer
- m. The shape of the chamfer of the spline shaft end
- n. Application of hollow shaft
- o. O ring position
- p. Maximum length
- q. Whether there are other precedents

7.2 Position of the keyway and flange hole of the spline nut

Among all types of ball splines, the keyway in the outer diameter of the spline nut is shown in Figure 7-2 and is machined according to the position of the ball circulation.

In addition, the flange holes in the flange-type nuts are in the position shown in Figure 7-3.

Specify the position of the processed keyway, etc., on the spline shaft when placing orders.

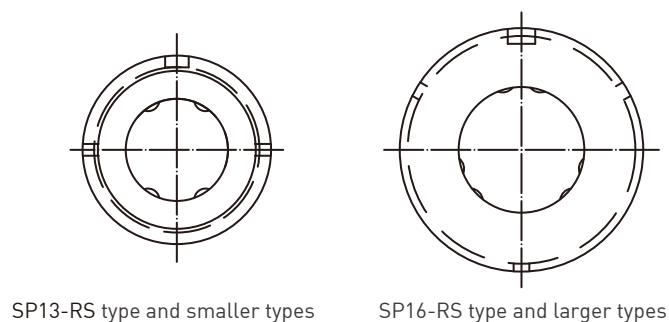

Figure 7-2 Position of the spline groove for RS type

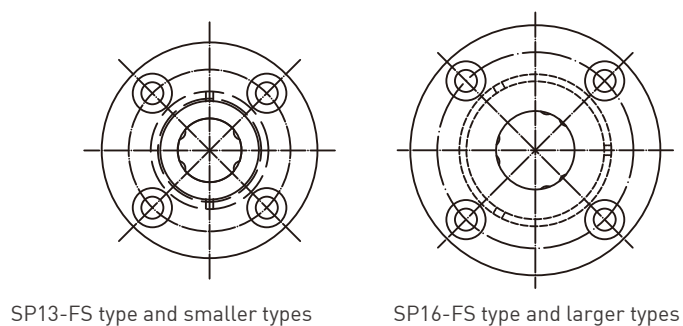

Figure 7-3 Position of spline flange hole for FS type

8. Installation steps

1. Recommended tolerance for spline nut mounting surface.

When specifying the tolerance for the diameter of the mounting surface for the spline nut bracket, it is generally recommended to use a transition fit (J6) for best accuracy. However, a clearance fit (H7) may be used in cases where accuracy requirements are lower.

2. Examples of installation of the ball spline

Examples are shown in the table below. Although the tightness demand of the ball spline assembly does not need to be very high, it is important to avoid installing them without fixing them.

Table 8-1. Examples of installation of the ball spline

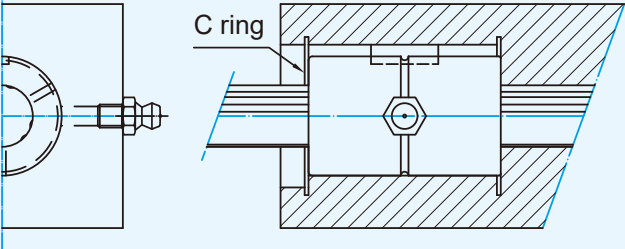
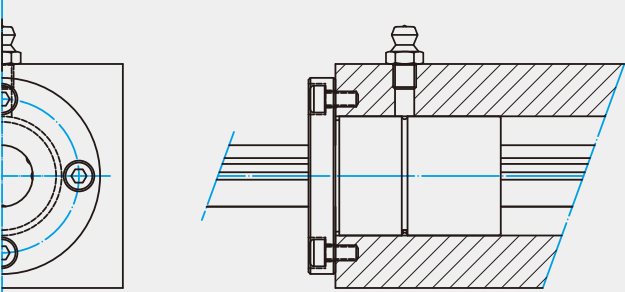
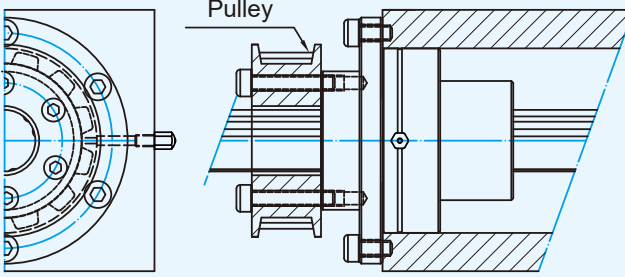
RS type	
FS type	
FRS type	

3. Installation of the ball spline nut

When installing the spline nut into the mounting surface, insert it slowly using the installation jig without hitting the C ring or the dustproof ring.

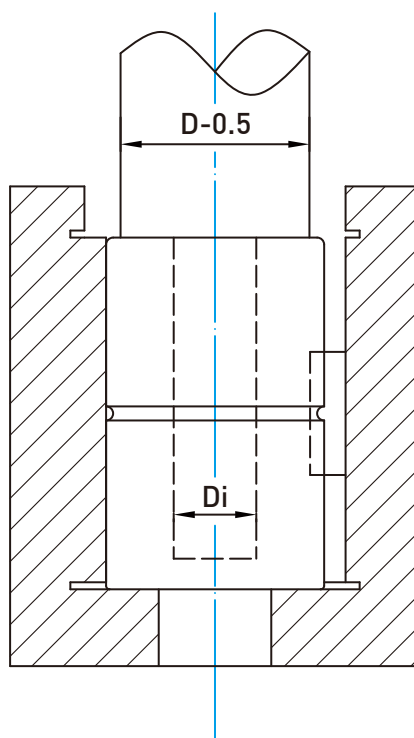

Figure 8-1. Schematic diagram of installing the jig

Table 8-2. Recommended jig dimensions

Nominal shaft diameter	13	16	20	25	32
Di	11.5	14.5	18.5	23	28

4. Installation of the ball spline shaft

When inserting the spline shaft into the spline nut, take care to insert the spline shaft perpendicular to the spline nut insert the straight groove of the spline shaft along the positing guide part of the retainer or the dustproof ring. Do not force the spline nut in to avoid the balls falling out of the retainer.

If the spline nut is equipped with a dustproof ring or preloaded, lubricate the outer diameter of the spline shaft with lubrication grease in advance.

9. Option of ball spline

Lubrication

The lubrication varies depending on the conditions of use, but in general, the grease should be replenished at a running distance of 100km (6 months~1 year). Lubricate the spline shaft by applying grease to the rolling groove or injecting grease into the nut lubrication hole, as shown in Figure 9-1.

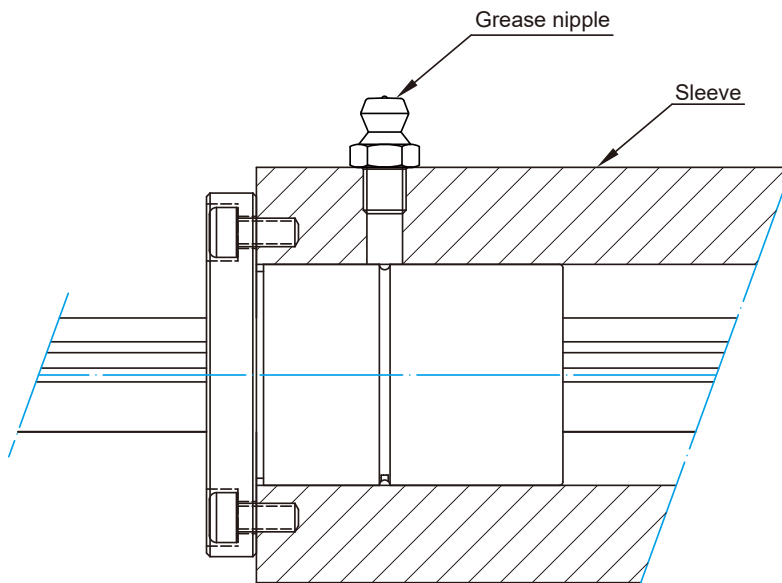

Figure 9-1. Lubrication method

Material and surface treatment

Depending on the conditions of use, the ball spline may be treated by rust prevention or be manufactured with different material. Please contact HIWIN for the rust prevention treatment and change of material used.

10. Precautions for use

Transportation/Assembly

- (1) When transporting heavy products (20kg or more), two or more people or transporting equipment is requested. Otherwise, it may result in scratches or damage.
- (2) Do not disassemble any part. Otherwise, it may result in loss of function.
- (3) The spline nut and spline shaft may fall by their weight when tilting, so be careful.
- (4) Do not allow the ball spline to fall or be impacted. Otherwise, it may result in scratches or damage. In addition, even if the damage is not visible from the outside, it may result in loss of function if it is hit.
- (5) When assembling, do not remove the spline nut from the spline shaft.
- (6) When using the product, wear protective gloves, safety shoes, etc., as necessary to ensure safety.

Precautions for use

- (1) Please take care to prevent the inflow of foreign objects into the nut such as particles and coolant. Otherwise, it may result in damage.
- (2) When using the product in an environment where particles, coolant, corrosive solvents, water, etc. may flow into the product, use a soft telescopic sheath or dustproof cover to prevent them from flowing into the product.
- (3) Do not use at temperatures exceeding 80°C. Except for the heat resistant type, if the temperature is exceeded, it may cause deformation and damage to the resin and rubber parts.
- (4) If foreign objects such as metal shavings are attached, clean and lubricate again.
- (5) During short stroke application, it is difficult to form an oil film on the contact surface of rolling elements, and micro-abrasion may occur, so use a lubrication grease with high micro-abrasion resistance. In addition, it is recommended to form an oil film on the rolling elements periodically by applying a stroke of about the length of the spline nut.
- (6) Do not force the position parts (pins, keys, etc.) into the product. Otherwise, the rolling surface may become indented and may result in loss of function.
- (7) In case of misalignment or skewing of the supporting part of the spline shaft and spline nut, the service life will be extremely shortened. Please pay attention to the installation parts and installation accuracy.
- (8) If the spline nut is inserted into the spline shaft and used in the absence of the steel balls, premature damage may occur.
- (9) If any steel balls falls out of the spline nut, do not continue to use this product and contact HIWIN.
- (10) When installing the spline shaft into the spline nut, check the position in relation to the shaft and the spline nut while inserting the shaft into the spline nut without any inclination, since there is a comparison mark on the spline shaft and the spline nut. If it is inserted too forcibly, the balls may fall out. Please pay special attention. Apply lubricant to the outer diameter of the spline shaft when inserting the spline nut with a dustproof ring or the preloaded spine nut.
- (11) When inserting the spline nut into the shaft, insert it slowly using a jig without hitting the side plate, end cap ring or dustproof ring.
- (12) If the stiffness and accuracy of the installation components are not sufficient, the load on the bearing will be concentrated locally, and the performance of the bearing will be significantly reduced. Therefore, give due consideration to the stiffness and accuracy of the support seat and base seat and the strength of the fixing screws.
- (13) Please contact HIWIN when machining positioning pin holes on the ball spline with flanges, etc.

Lubrication

- (1) Wipe off the rust-proof oil carefully and lubricate before use.
- (2) Do not mix different lubricants together for use. Even lubricant greases with the same type of thickening agent may affect each other due to different additives, etc.
- (3) Use the lubricant grease that fits the specifications and environment if it is used in a special environment, such as a place where there is a lot of vibration, a clean room, vacuum, or low or high temperature.
- (4) When lubricating a product without a grease nipple or oil hole, apply lubricant directly to the rolling surface and make several test runs in order to inject the lubrication grease into the product.
- (5) The consistency of lubrication grease varies depending on the temperature. The sliding resistance of the ball spline changes due to the change in consistency, so please pay attention to it.
- (6) After adding lubrication grease, the mixing resistance of the lubrication grease may cause an increase in the sliding resistance of the ball spline. Make sure to carry out a test run and operate the machine after getting used to the lubrication grease.
- (7) After adding lubrication grease, excess lubrication grease may be dispersed to the surrounding area, so wipe it off before use if necessary.
- (8) The lubricant properties will deteriorate over time, so it is necessary to check and replenish the lubrication grease according to the frequency of use.
- (9) The lubrication interval varies depending on the conditions and environment of use. It is recommended to lubricate the system approximately every 100km travel distance (3-6 months). The final lubrication interval should be set according to the actual machine.
- (10) When lubricating with oil, sometimes the lubricant may not reach due to the installation direction of the ball spline. Please contact HIWIN in advance for details.

Storage

When storing the ball spline, place it in the HIWIN specified package and store it horizontally in the room to avoid high and low temperatures and high humidity. Since the internal lubricant will deteriorate over time, store the product for a long time, lubricate it again before use.

Disposal

Please discard the product as industrial waste as appropriate.

MEMO

A series of horizontal dotted lines for writing.

Ball Spline Technical Information

Publication Date : April 2022, first edition

-
1. HIWIN is a registered trademark of HIWIN Technologies Corp.. For your protection, avoid buying counterfeit products from unknown sources.
 2. Actual products may differ from specifications and photos provided in this catalog. These differences may be the result of various factors including product improvements.
 3. HIWIN website for patented product directory: http://www.hiwin.tw/Products/Products_patents.aspx
 4. HIWIN will not sell or export products or processes restricted under the "Foreign Trade Act" or related regulations. Export of restricted products should be approved by proper authorities in accordance with relevant laws and shall not be used to manufacture or develop nuclear, biochemical, missiles or other weapons.



Global Sales and Customer Service Site

HIWIN GmbH

OFFENBURG, GERMANY
www.hiwin.de
www.hiwin.eu
info@hiwin.de

HIWIN JAPAN

KOBE · TOKYO · NAGOYA · NAGANO ·
TOHOKU · SHIZUOKA · HOKURIKU ·
HIROSHIMA · FUKUOKA · KUMAMOTO,
JAPAN
www.hiwin.co.jp
info@hiwin.co.jp

HIWIN USA

CHICAGO, U.S.A.
www.hiwin.us
info@hiwin.com

HIWIN Srl

BRUGHERIO, ITALY
www.hiwin.it
info@hiwin.it

HIWIN Schweiz GmbH

JONA, SWITZERLAND
www.hiwin.ch
info@hiwin.ch

HIWIN s.r.o.

BRNO, CZECH REPUBLIC
www.hiwin.cz
info@hiwin.cz

HIWIN FRANCE

STRASBOURG, FRANCE
www.hiwin.fr
info@hiwin.de

HIWIN SINGAPORE

SINGAPORE
www.hiwin.sg
info@hiwin.sg

HIWIN KOREA

SUWON · CHANGWON, KOREA
www.hiwin.kr
info@hiwin.kr

HIWIN CHINA

SUZHOU, CHINA
www.hiwin.cn
info@hiwin.cn

Mega-Fabs Motion Systems, Ltd.

HAIFA, ISRAEL
www.mega-fabs.com
info@mega-fabs.com

HIWIN TECHNOLOGIES CORP.

No. 7, Jingke Road,
Taichung Precision Machinery Park,
Taichung 40852, Taiwan
Tel: +886-4-23594510
Fax: +886-4-23594420
www.hiwin.tw
business@hiwin.tw